



Nissan Patrol Y62
MY2020+ (Series 5)
Cobra and Toro Front Bar Fitting
Instruction

IMPORTANT! – READ BEFORE INSTALLATION

- When installed in accordance with these instructions, the front protection bar does not affect the operation of the vehicles SRS airbags.
- This product must be installed exactly as per these instructions using only hardware supplied.
- Take a few moments to read instructions thoroughly before beginning work.
- In the event of damage to any bar component please contact OFFROAD ANIMAL to arrange repair/replacement of components.
- Do not use this product for any vehicle make or model other than that specified on these instructions.
- Do not remove labels from this product.
- This product and its fixings must not be modified in any way unless stated in these fitting instructions.
- The installation of this product is recommended for trained personnel.
- These instructions are correct at time of publication. OFFROAD ANIMAL cannot be held responsible for the impact of any changes subsequently made by the vehicle manufacturer. If you find something has changed please contact us to let us know!
- During installation it is the duty of the installer to check correct operation/clearances of all components.
- If Instructions are to be printed for reference in the workshop, it is recommended that they are printed in colour, for best legibility.

PARTS LISTING

IMPORTANT: Check all parts are present before beginning work! Contact OFFROAD ANIMAL if something is missing.

Main Parts – In the Box

Qty	Part Number	Description	Image
1	FB-NPT-Y62-19-PR-ASM1	Patrol Y62 Cobra Bar Weldment	
Or			
1	FB-NPT-Y62-19-TOR-ASM1	Patrol Y62 Toro Bar Weldment	
1	FB-NPT-Y62-19-PR-ASM2L	Y62 Patrol Impact Assy LH	
1	FB-NPT-Y62-19-PR-ASM2R	Y62 Patrol Impact Assy RH	
1	FB-NPT-Y62-19-PR-ASM3L	Nissan Patrol Y62 Tow Point Assy LH	



1	FB-NPT-Y62-19-PR-ASM3R	Nissan Patrol Y62 Tow Point Assy RH	
1	B-0462L	Patrol Y62 Chassis Brace LH	
1	B-0462R	Patrol Y62 Chassis Brace RH	
1	U-0031	Patrol Y62 Series 5 Center Bash Plate	
1	U-0032L	Patrol Y62 Series 5 Side Underpanel LH	
1	U-0032R	Patrol Y62 Series 5 Side Underpanel RH	
1	M-0018	Y62 Patrol Mesh Fairlead Mount	



1	M-0008L	LC200 Mesh Infil Panel LHS	
1	M-0008R	LC200 Mesh Infil Panel RHS	
1	M-0021L	Patrol Y62 Light Cover Mesh LH	
1	M-0021R	Patrol Y62 Light Cover Mesh RH	
1	B-0467L	Nissan Patrol Y62 Fog Light Bracket LH	
1	B-0467R	Nissan Patrol Y62 Fog Light Bracket RH	



FB-NPT-Y62-19-PR-ASMO
Fitting Instruction

2020+ Nissan Patrol Y62 S5
Predator Front Bar

1	NPF-COM-SM-ASMO	Number plate flip asm Small	
1	B-0463	Patrol Y62 Series Radar Bracket	
1	B-0729	Patrol Y62 Pan Brace	
1	P-0169	Y62 Radar Cover Plate	



Cobra Small Parts – Contained in Small Parts Kit Bag

QTY.	PART NO.	DESCRIPTION
24	M6 FLANGE NUT	Flange Nut, M6x1 G8.8 ZP
33	M6x16 BHCS BLACK ZINC	SCREW, BUTTON HEAD CAP, M6X16X1 GR12.9 BLACK ZP
33	M6 FLAT WASHER BLACK ZINC	M6 FW BLACK ZP
10	M6CN3MM	CAGE NUT M6x SUIT 2.6-3.5MM SHEET
6	M8 X 30 BHCS BLACK ZINC	SCREW, BUTTON HEAD CAP, M8X30X1.25 BLACK ZP
16	M8 FLANGE NUT	Flange Nut, M8x1.25 G8.8 ZP
10	M8 FLAT WASHER- BLACK ZINC	M8 FW- BLACK ZINC
10	M8 X 20 HEX	Bolt Hex, M8X20x1.25, GR8.8 ZP
10	M8 FLAT WASHER	M8 Flat Washer, Zinc Plate
5	M10 x 30	Bolt Hex, M10X30x[1.5], GR8.8 ZP
10	M10 FLANGE NUT	Flange Nut, M10x1.5 G8.8 ZP
11	M10 Flat Washer	M10 Flat Washer, Std Zinc Plate
4	M8 X 16 BHCS BZP	SCREW, BUTTON HEAD CAP, M8X16X1.25 GR12.9 BLACK ZP
2	M12X50x1.25	Bolt Hex, M12X50x1.25, GR8.8 ZP
22	M12 FW LHD	M12 FW Large Heavy Duty
8	M12X30	Bolt Hex, M12X30x1.75, GR8.8 ZP
4	M12X50	Bolt Hex, M12X50x1.75, GR8.8 ZP
4	M12 Nyloc nut	M12 NYLOC NUT
2	M8 HD FLAT WASHER	M8 FLAT WASHER - High Tensile 19x8x1.9mm
2	M8 X 40 HEX	Bolt Hex, M8X40X1.25, GR8.8 ZP
4	NP-COM-M12-300-ASMO	M12 NUT PLATE 300MM STEM
2	P-0024	Ranger tow point spacer
4	M10 X 40	Bolt Hex, M10X40X1.5, GR8.8 ZP
2	M10 x 25	Bolt Hex, M10X25x[1.5], GR8.8 ZP
4	M12 FLANGE NUT	Flange Nut, M12x1.75 G8.8 ZP
2	HC-000-SS	Hose Clamp, Worm Gear Type, Size 000 6-16mm Grip, Stainless Steel
3	M10 Nutsert	M10 Nutsert
1	M12X30X1.25	Bolt Hex, M12X30x1.25, GR8.8 ZP
3	M10 FW LHD	WASHER, FLAT M10X28.5X2.5
3	M10 X 50	Bolt Hex, M10X50X1.5, GR8.8 ZP
1	M6 X 12 BHCS	SCREW, BUTTON HEAD CAP, M6X12X1 GR12.9 ZP



Toro Small Parts – Contained in Small Parts Kit Bag

QTY.	PART NO.	DESCRIPTION
24	M6 FLANGE NUT	Flange Nut, M6x1 G8.8 ZP
33	M6x16 BHCS BLACK ZINC	SCREW, BUTTON HEAD CAP, M6X16X1 GR12.9 BLACK ZP
33	M6 FLAT WASHER BLACK ZINC	M6 FW BLACK ZP
10	M6CN3MM	CAGE NUT M6x2.6-3.5
6	M8 X 30 BHCS BLACK ZINC	SCREW, BUTTON HEAD CAP, M8X30X1.25 BLACK ZP
16	M8 FLANGE NUT	Flange Nut, M8x1.25 G8.8 ZP
10	M8 FLAT WASHER- BLACK ZINC	M8 FW- BLACK ZINC
14	M8 X 20 HEX	Bolt Hex, M8X20x1.25, GR8.8 ZP
14	M8 FLAT WASHER	M8 Flat Washer, Zinc Plate
5	M10 x 30	Bolt Hex, M10X30x[1.5], GR8.8 ZP
10	M10 FLANGE NUT	Flange Nut, M10x1.5 G8.8 ZP
11	M10 Flat Washer	M10 Flat Washer, Std Zinc Plate
4	M8 X 16 BHCS BZP	SCREW, BUTTON HEAD CAP, M8X16X1.25 GR12.9 BLACK ZP
2	M12X50x1.25	Bolt Hex, M12X50x1.25, GR8.8 ZP
22	M12 FW LHD	M12 FW Large Heavy Duty
8	M12X30	Bolt Hex, M12X30x1.75, GR8.8 ZP
4	M12X50	Bolt Hex, M12X50x1.75, GR8.8 ZP
4	M12 Nyloc nut	M12 NYLOC NUT
2	M8 HD FLAT WASHER	M8 FLAT WASHER - High Tensile 19x8x1.9mm
2	M8 X 40 HEX	Bolt Hex, M8X40X1.25, GR8.8 ZP
4	NP-COM-M12-300-ASMO	M12 NUT PLATE 300MM STEM
2	P-0024	Ranger tow point spacer
4	M10 X 40	Bolt Hex, M10X40X1.5, GR8.8 ZP
2	M10 x 25	Bolt Hex, M10X25x[1.5], GR8.8 ZP
4	M12 FLANGE NUT	Flange Nut, M12x1.75 G8.8 ZP
2	HC-000-SS	Hose Clamp, Worm Gear Type, Size 000 6-16mm Grip, Stainless Steel
3	M10 Nutsert	M10 Nutsert
1	M12X30X1.25	Bolt Hex, M12X30x1.25, GR8.8 ZP
3	M10 FW LHD	WASHER, FLAT M10X28.5X2.5
3	M10 X 50	Bolt Hex, M10X50X1.5, GR8.8 ZP
1	M6 X 12 BHCS	SCREW, BUTTON HEAD CAP, M6X12X1 GR12.9 ZP



TOOLS REQUIRED

The following tools will be required to install the product.

Hand Tools	Power Tools	Workshop Supplies
Metric Socket Set 8-19mm Socket Extension Bar Metric Spanner Set 10-19mm Hex (Allen) Key Set 4-6mm Trim Puller Tool Flat Blade Screwdriver set Phillips Head Screwdriver set Utility Knife Side Cutters Pliers	Electric Drill 6mm Drill Bit Air Hacksaw or Angle Grinder Electric/Air Impact Driver (Optional) Soldering Iron	Double Sided Adhesive Tape Panel Stand or Soft Blanket Cable Ties Masking Tape Black Automotive paint Scotch Brite or Fine Sandpaper Automotive Sealant/Adhesive Bucket Hose Clamp Signal Wire Wire Terminals

WORKSHOP SAFETY

It is the responsibility of the installer to always complete works in a safe manner. Make sure the following safety equipment is available and precautions are observed whilst fitting this product.

<p>Hearing Protection</p> 	<p>Always wear ear protection when using power tools.</p>
<p>Eye Protection</p> 	<p>Ensure eye protection is always worn when cutting or drilling.</p>
<p>Manual Handling</p> 	<p>Do not attempt to lift bar assemblies or rock sliders on your own.</p> <p>Always use two people to lift or use mechanical Lifting aid such as hydraulic lifting trolley.</p>
<p>Vehicle Support</p> 	<p>Always ensure vehicle is properly supported when working on it. Do not attempt to fit products whilst suspension work is being carried out. Do not work under a vehicle supported only by a jack.</p>



1. Open the Bonnet,
2. Remove clips securing the top radiator cowl.
Lever up center of clip to unlock, then remove clip with trim tool.
3. Retain all clips for reassembly.

TOOLS REQUIRED

Trim Tool / Flat Screwdriver

FASTENERS

Retain Factory

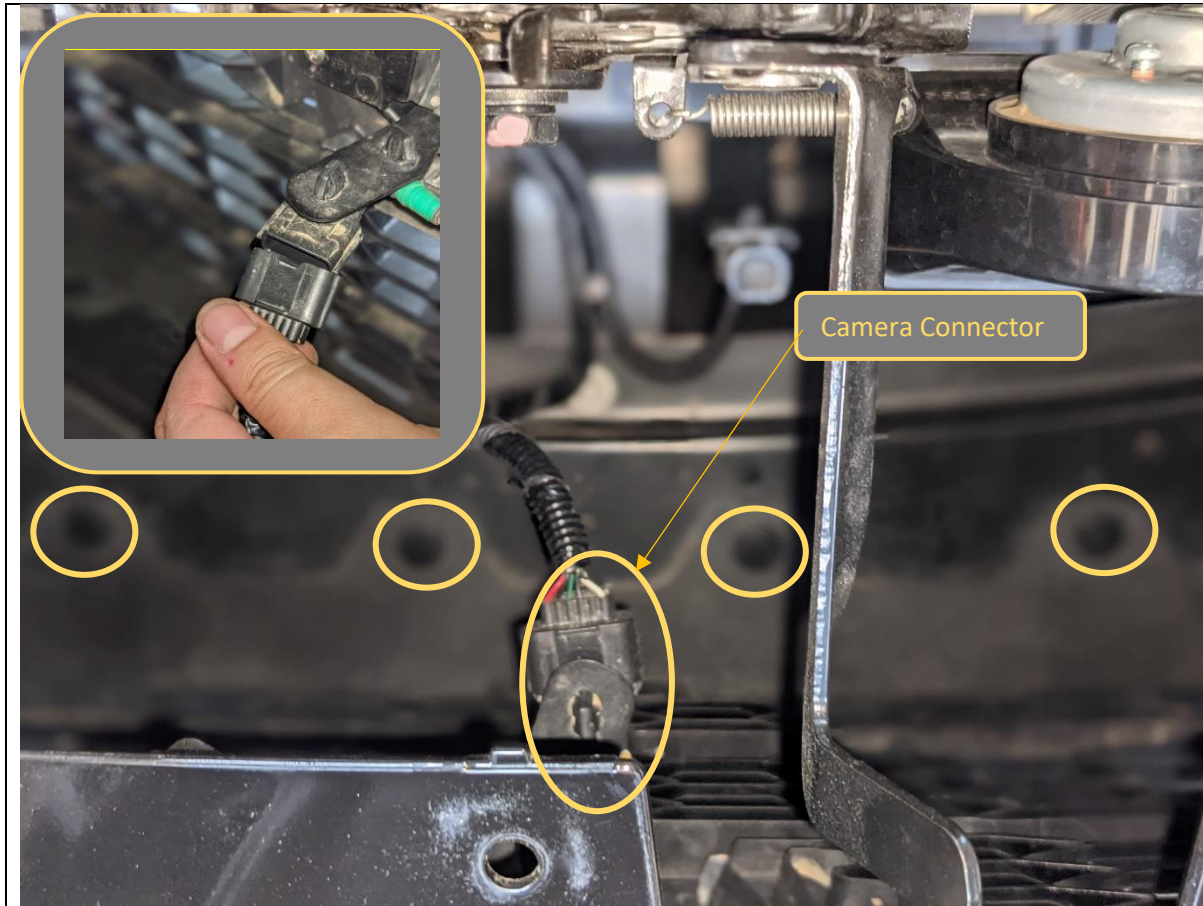

4. Disconnect the electrical harness connectors on the back of the front camera located under the "Nissan" Badge
5. Reaching down behind the grille use a trim tool to release the 6x center locking clips securing the bumper to the cross member.

TOOLS REQUIRED

Trim tool

FASTENERS

Factory Clips



6. Remove the 13mm head bolts securing the bottom of the bumper to the lower cross member. You will also need to remove the two metal brackets secured by the 18mm head bolts

TOOLS REQUIRED

18MM Socket
13mm Socket

FASTENERS

Factory bolts



7. Remove the two 13mm head bolts securing the bottom of the bumper on each side panel.
8. Remove any other fasteners from this area too, such as the aftermarket flare bolt fitted to this vehicle.

TOOLS REQUIRED

13mm Socket

FASTENERS

Factory Bolts



9. Using a Rag to protect the trim and headlight carefully pry the upper headlight trim away from the clips securing it to the headlight.

TOOLS REQUIRED

Trim Tool

FASTENERS

Factory Clips



10. Remove the center lock clips that secure the bottom of the grille to the cross member.
11. Carefully pull out from the top of the grille to release the push in type clips securing top of grille. The grille should now be loose and only connected on the bottom edge to the bumper.

TOOLS REQUIRED

Trim Tool

FASTENERS



12. Remove the 10mm screws securing bumper to the wheel arch liner. This is recessed and will require a ring end spanner to reach

13. Complete on both sides of the vehicles

TOOLS REQUIRED

10mm Ring spanner

FASTENERS



14. Starting from the wheel arch, carefully pull the bumper away from the body of the vehicle to release the clips.

Disconnect the main electrical harness, located on the RHS of vehicle under headlight.

15. Disconnect the headlight washer hose at the quick connect fitting.

If there is any washer fluid in the reservoir it will spill out. Have a bucket on hand to drain the washer fluid or use a clamp to prevent the fluid from leaking

16. Once both are disconnected continue removing bumper. Once all clips are released, carefully lift the bumper from the car and set aside on a soft surface.

TOOLS REQUIRED

FASTENERS



17. Once bumper is removed vehicle should look as above.

18. Note. If fitting a winch with integrated control box, or top mounted control box the center cross member will need to be removed or modified. Now is a good time to determine and make the modifications required for you individual application.

19. Low mount winches with remote control packs will not require crossmember modification.

TOOLS REQUIRED

FASTENERS



20. Remove the grille from the bumper by releasing the clips securing it to the bumper.

TOOLS REQUIRED

Flat screwdriver

FASTENERS



21. Disconnect the Fog light harness from the fog light.
22. Remove the fog lights from the bumper, by removing the 10mm head screws.
23. Remove both the electrical harness, and headlight washer pipes from the bar, by prying out the clips using trim tool.
24. Complete on both sides of bumper.

TOOLS REQUIRED

10mm Socket
Trim tool

FASTENERS

Discard Factory Screws

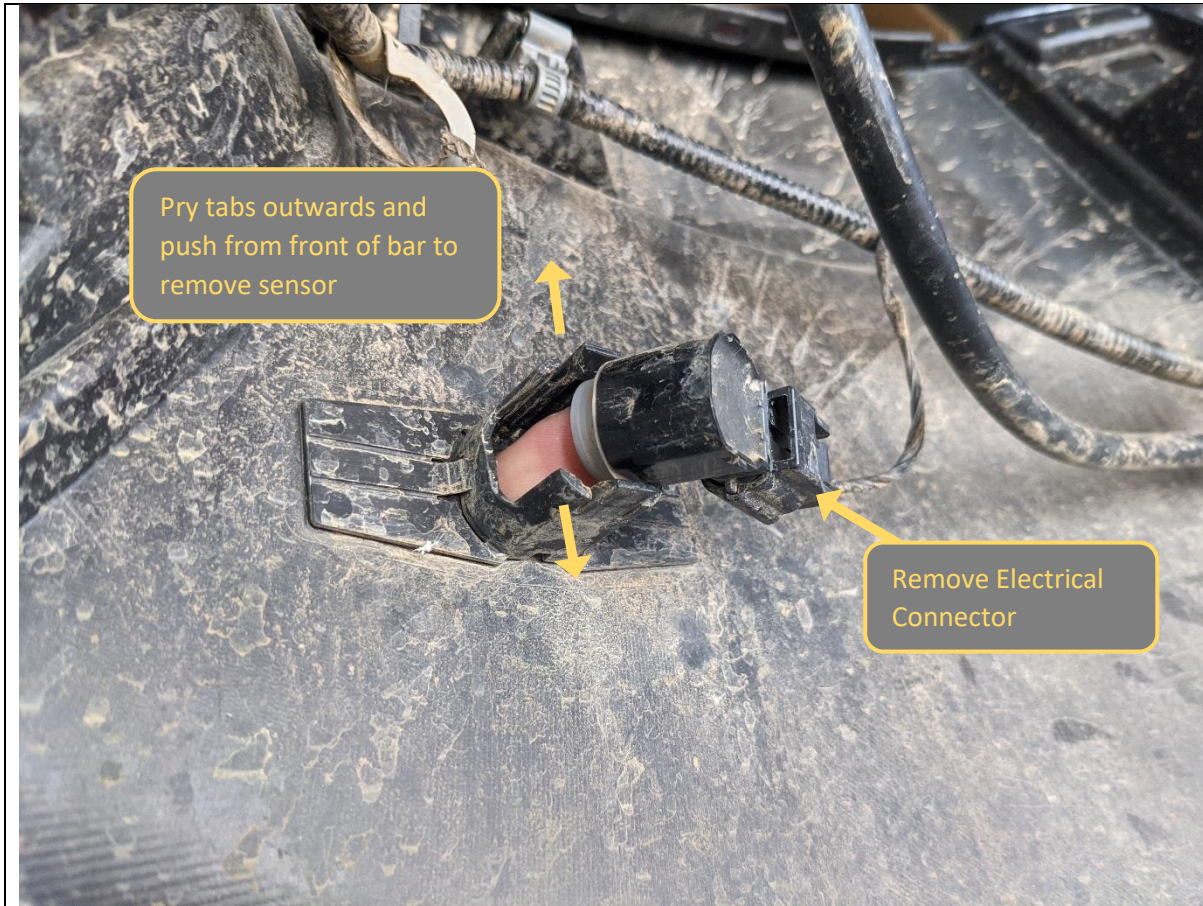

25. Disconnect the parking sensors from the loom by squeezing the tab, then pulling to disconnect the multi plug connector.

26. Pry the two retaining tabs on the sensor housing outwards whilst applying pressure to the face of the sensor from the front side of the bumper. The sensor should release from the housing. Remove from the rear side of the bumper.

Take care to ensure the rubber isolation rings remain in place with the sensor.

TOOLS REQUIRED

FASTENERS

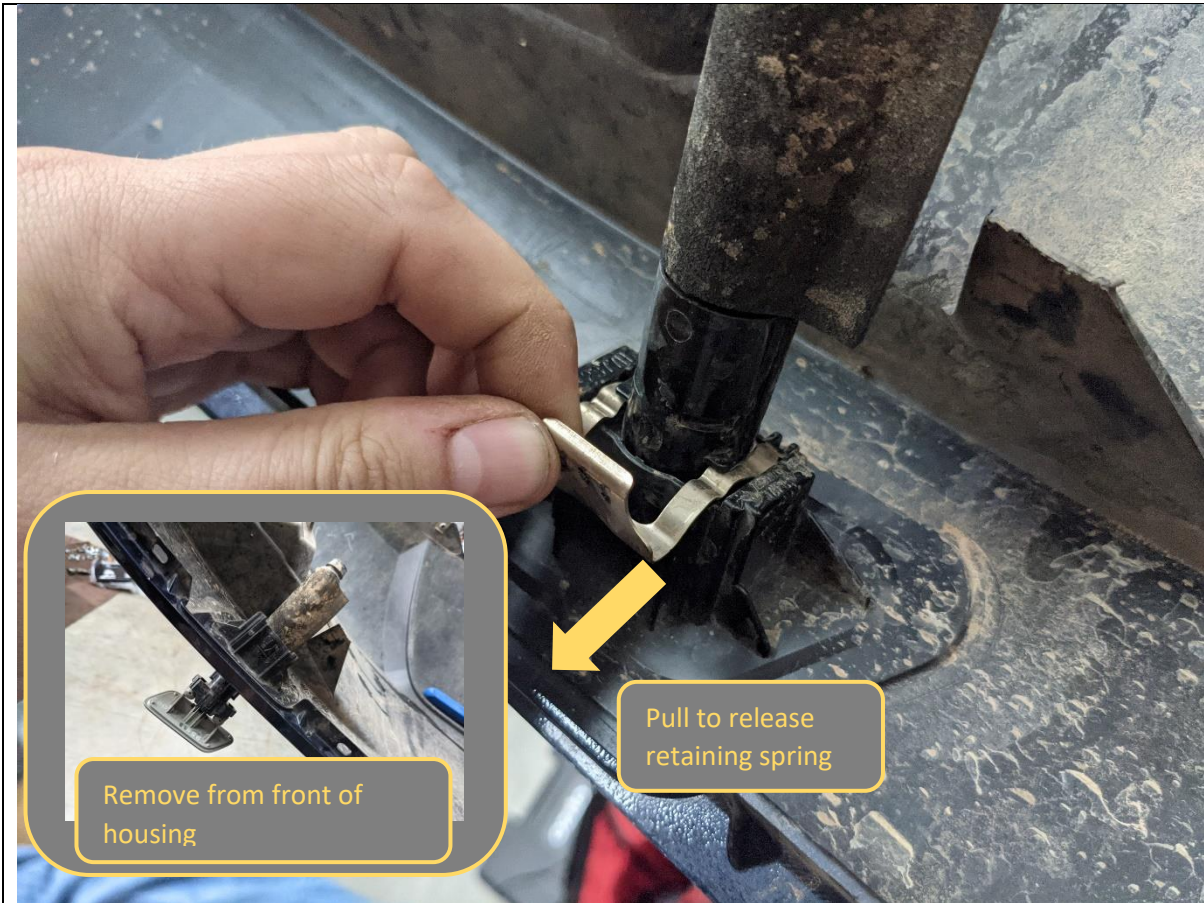

27. Remove headlight washers from the bumper. Start by disconnecting the supply hose.
28. Release the retaining spring by firmly pulling it as shown in the image.
29. Once loose, push from behind to remove washer assembly from front of the housing as shown.

TOOLS REQUIRED

FASTENERS

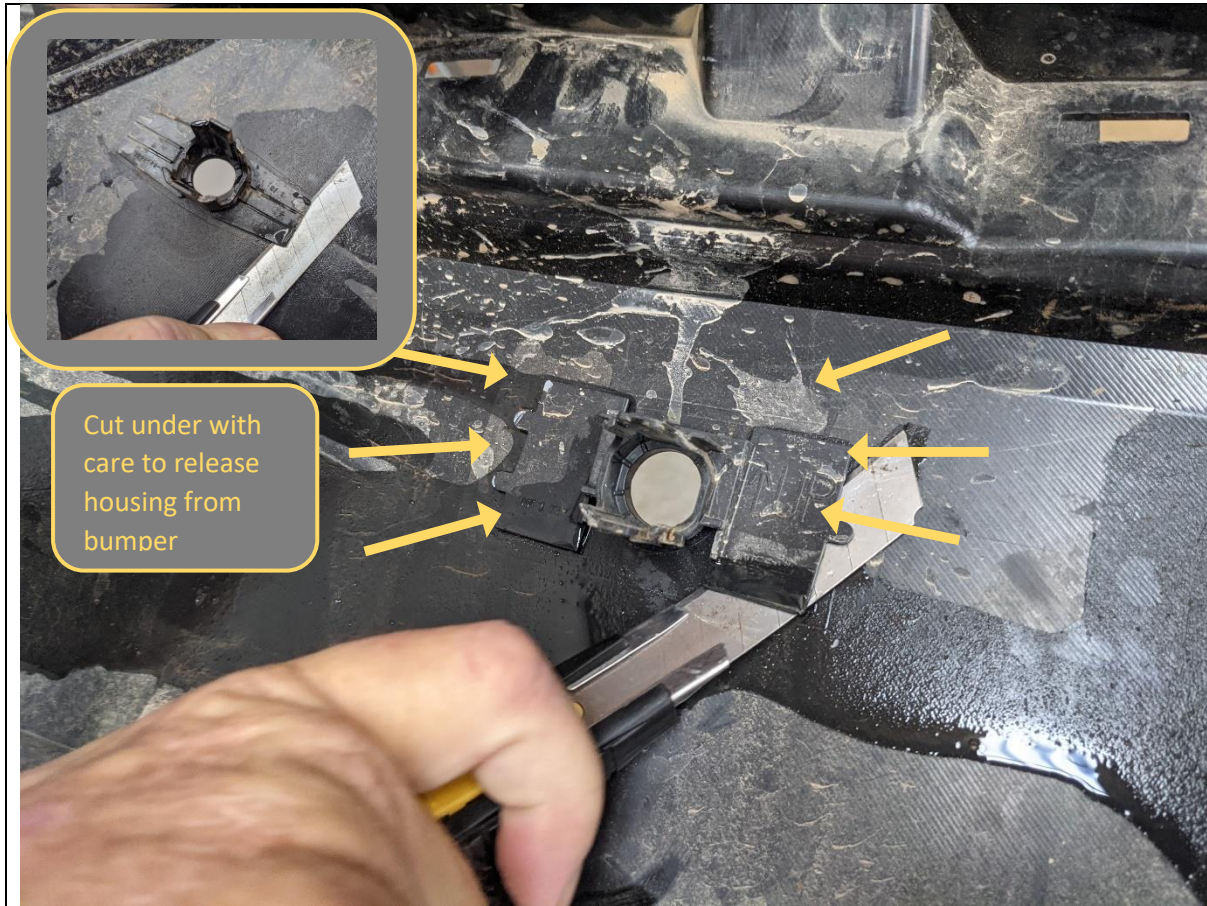

30. Remove the sensor housing from the bumper for refitment to the bar
31. Using a utility knife carefully cut through the adhesive under the grey parts of the sensor housing and pry it from the bumper
32. Set aside housings taking care to note the correct positions for refitment. Note that center and outside sensors have different housings.

TOOLS REQUIRED
Utility Knife
Trim Tool

FASTENERS

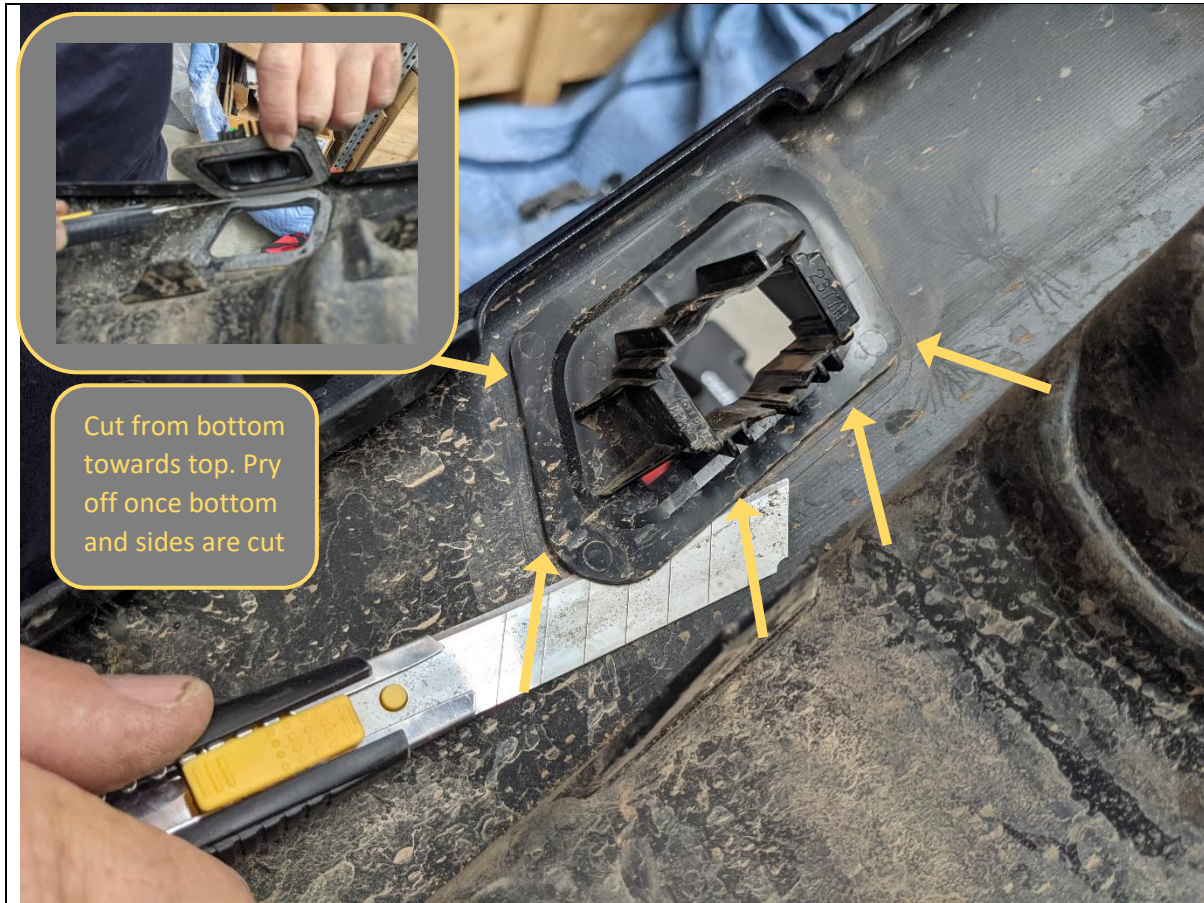

33. Remove the Washer housing from the bumper for refitment to the bar
34. Using a utility knife and trim tool carefully cut through the adhesive under the grey parts of the sensor housing and pry it from the bumper.
35. Start from the bottom and progressively cut up towards the top, then lever housing away from bumper as shown.
36. Set aside housings taking care to note the correct positions for refitment

TOOLS REQUIRED
Utility Knife
Trim Tool

FASTENERS



37. Using knife and solvents (such as isopropyl Alcohol) remove the adhesive tape residue from the sensor and washer housings

TOOLS REQUIRED

Utility Knife
Solvents
Rags

FASTENERS

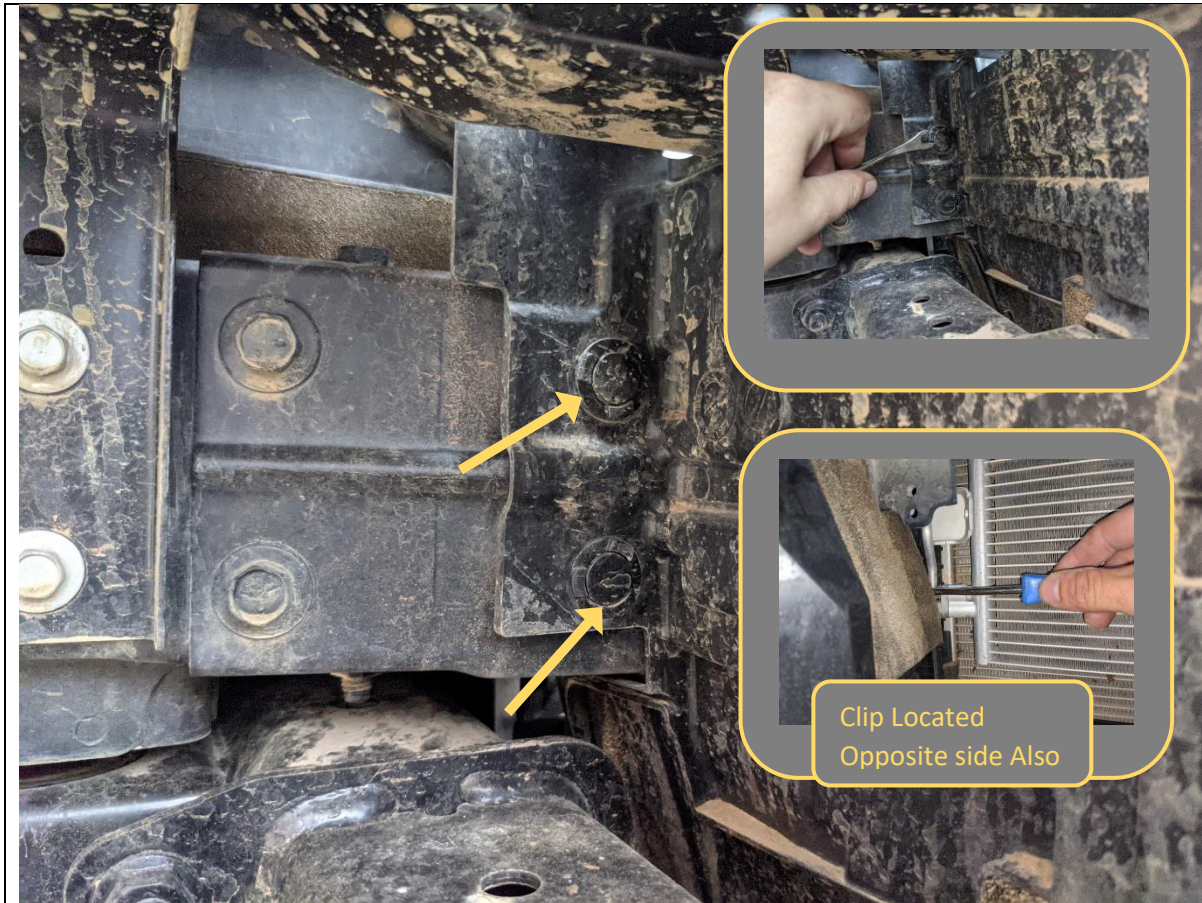

38. Remove the clips securing the lower air guides
39. Two clips are clearly visible and two are hidden, recessed on the inside of the air guide.
40. Remove and discard air guides
41. Complete on both sides of vehicle.

TOOLS REQUIRED

Trim Tool

FASTENERS



42. Remove the 8x 15mm head Nuts holding the impact beam to the Chassis rails.
43. Remove and set aside the impact beam.

TOOLS REQUIRED
15mm Socket

FASTENERS
6x 15mm Head factory Flange Nuts

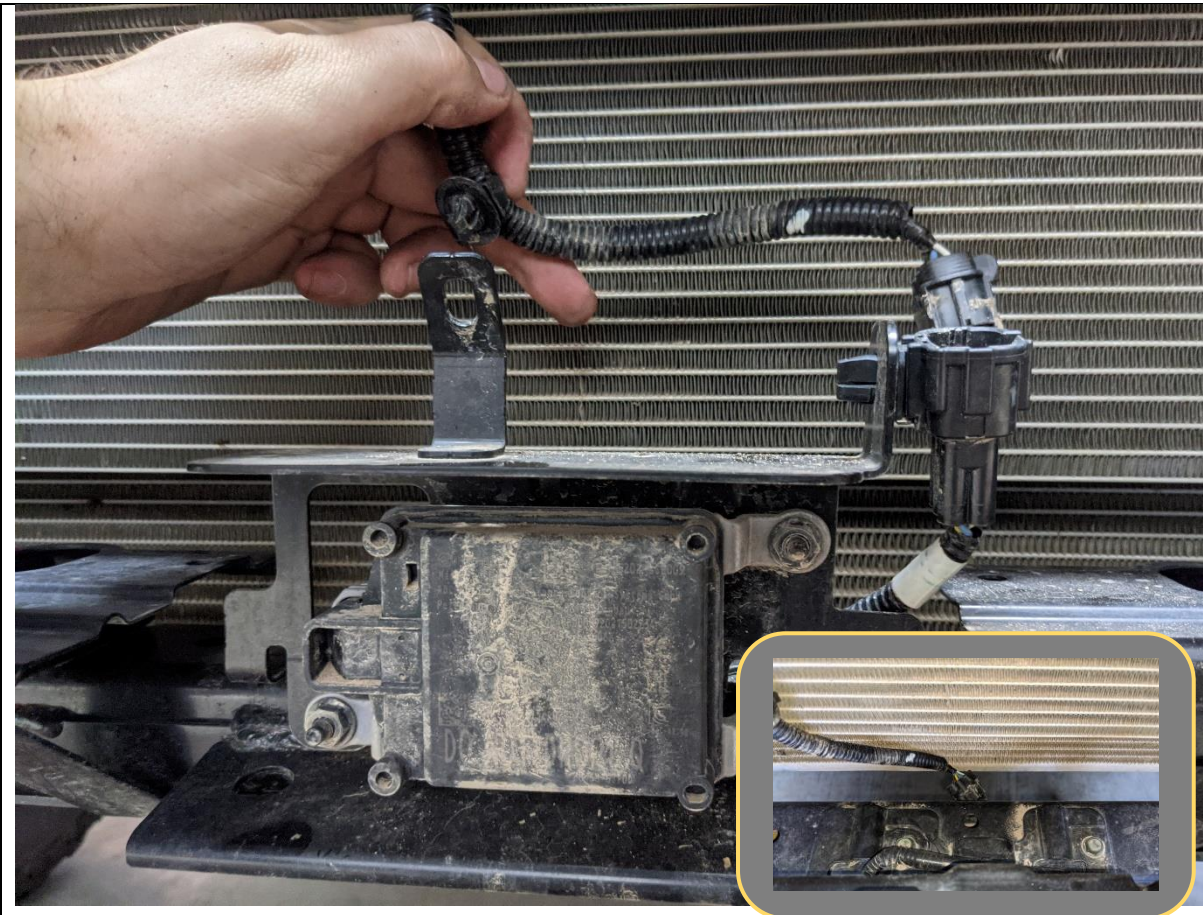

44. Disconnect the wiring harness on the radar sensor module.
45. Remove the sensor module bracket, by removing the two 10mm head bolts behind the module securing it to the cross member.

TOOLS REQUIRED
10mm Socket
Extension Bar

FASTENERS
2x Factory Bolts

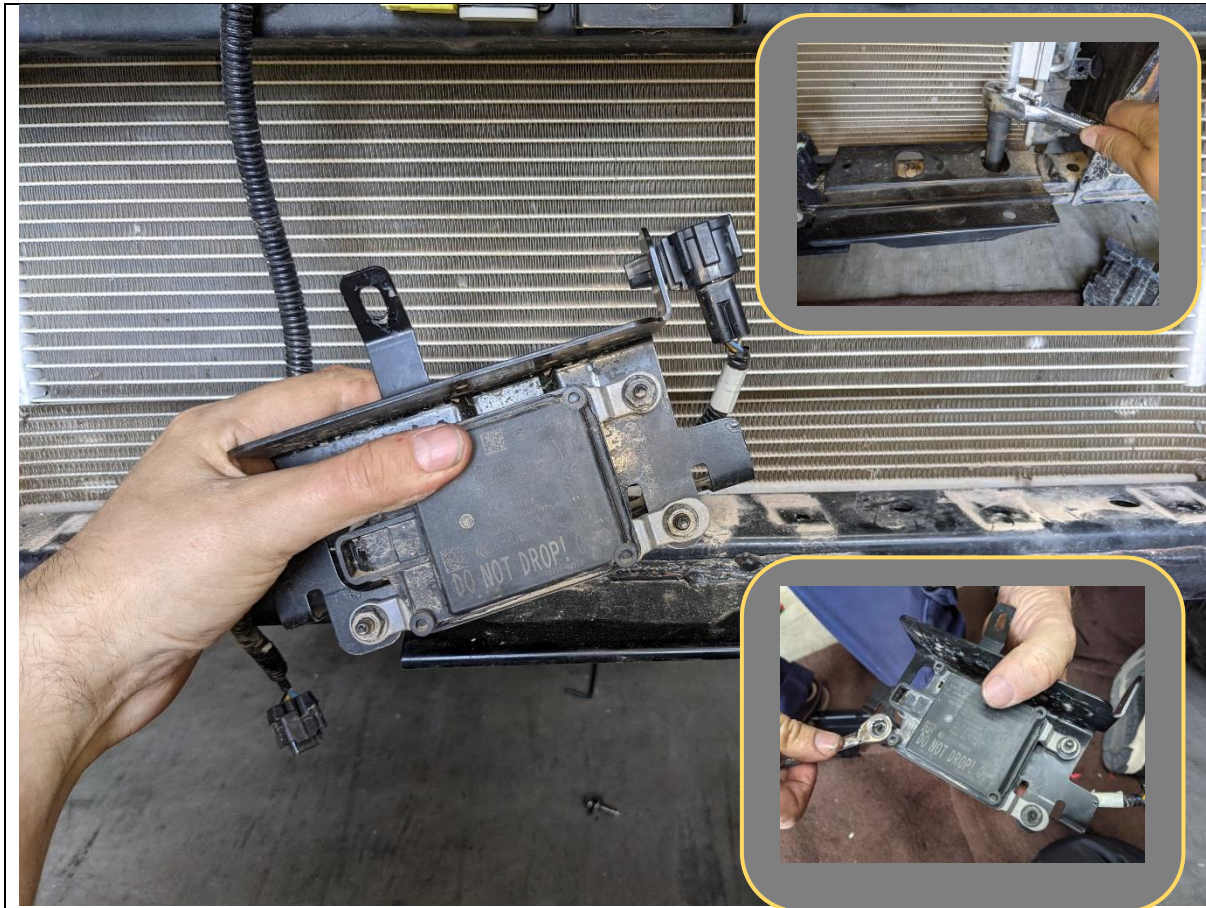

46. Carefully remove the radar module from the vehicle.
47. Next remove the module from the bracket by removing the 10mm nuts securing it to the bracket.
48. Set aside radar module in a safe place before refitment.
49. Remove the additional metal brackets from the lower cross member

TOOLS REQUIRED
14mm Socket
Extension Bar

FASTENERS
3x 10mm Head factory Flange Nuts



50. Remove the plastic bumper retainers by removing the Philips head and 10mm head screw, then prying out the large clip from behind using trim tool

TOOLS REQUIRED

Phillips head screwdriver
10mm Socket
Trim Tool

FASTENERS

Phillips Head screw.



51. Remove the top headlight trims from the bumper by removing the two 10mm head factory bolts.

52. Re fit the trim to the clips on the headlights, ensuring it sits flush with the guard.

TOOLS REQUIRED

10mm Spanner / Socket

FASTENERS

10mm Head Factory Flange Bolts

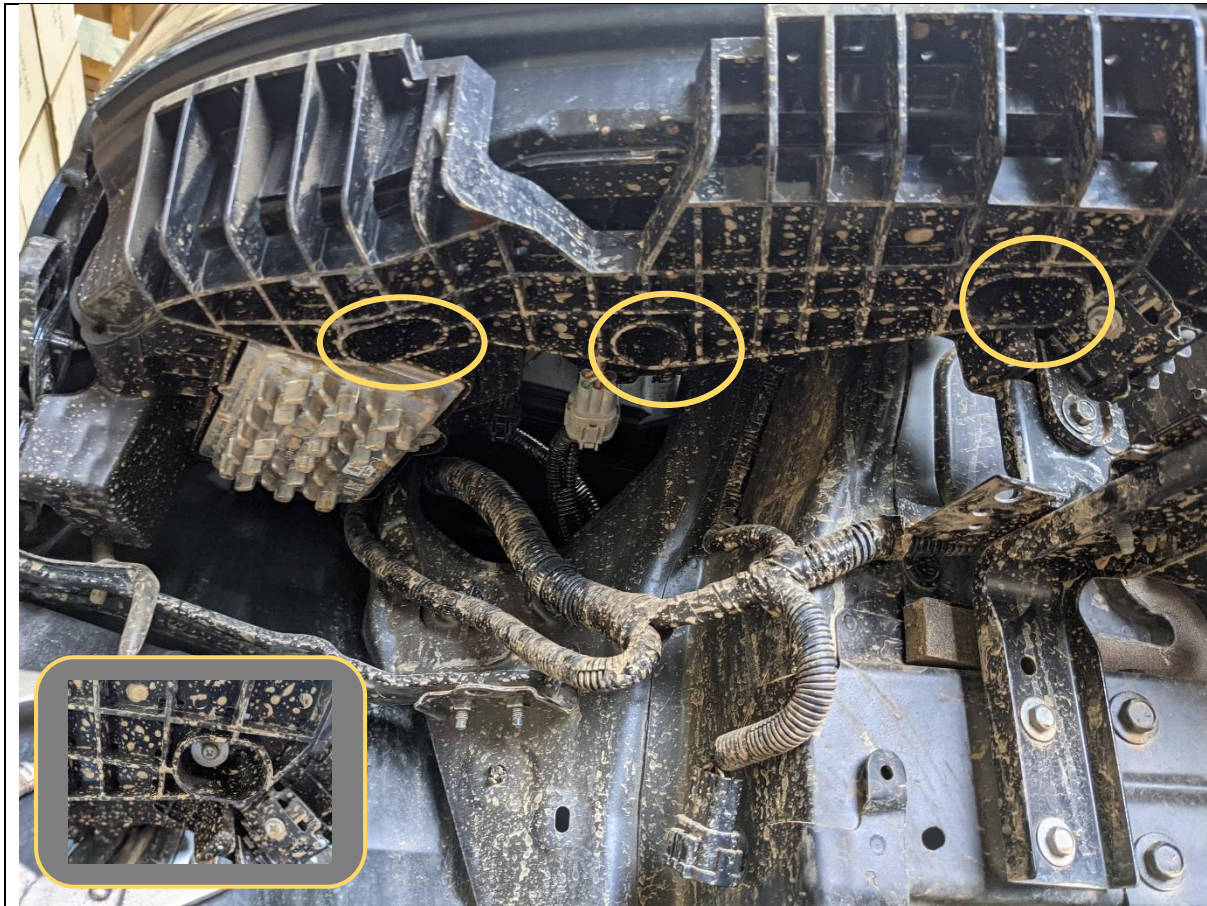

53. Remove the Plastic retainers under the headlights, by removing the Phillips head screws securing it.

54. Discard plastic retainers

TOOLS REQUIRED

Phillips head screwdriver

FASTENERS

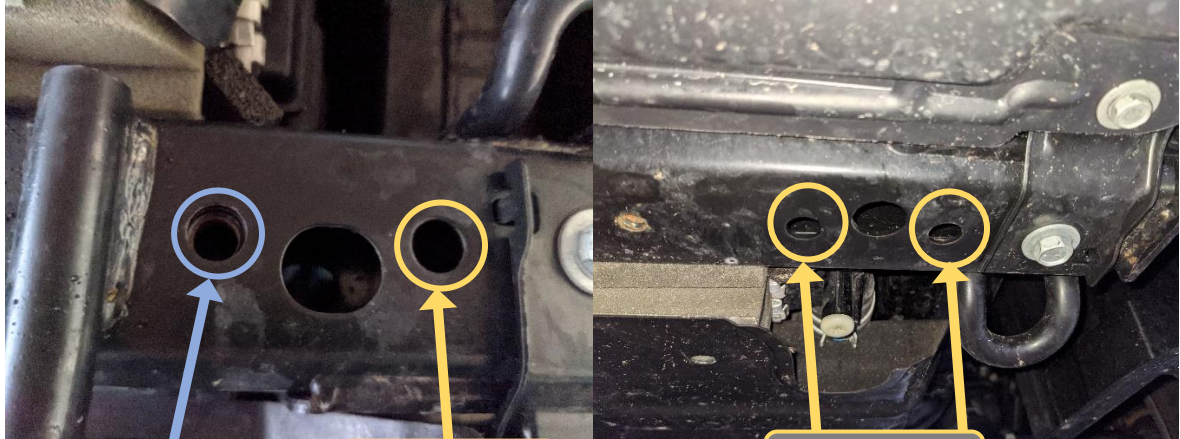
<p>RHS – One Nutsert Required</p>	<p>LHS – Two Nutserts Required</p>
	
<p>55. Ti-L Models Only</p> <p>Ti-L models are not fitted with the same threaded inserts in the chassis as the Ti Model.</p> <p>56. Locate the 3x holes on the underside of the forward chassis crossmember that do not contain threads on the Ti-L Model.</p> <p>57. Fit the 3x M10 Nutserts to these holes. If available use commercially available Pneumatic nutsert tool. You may need to open the hole up to 13mm</p> <p>58. If commercial nutsert tool is not available set the nutsert with Fasteners and two spanners as shown in steps on following page</p>	<p>TOOLS REQUIRED</p>
	<p>FASTENERS</p>

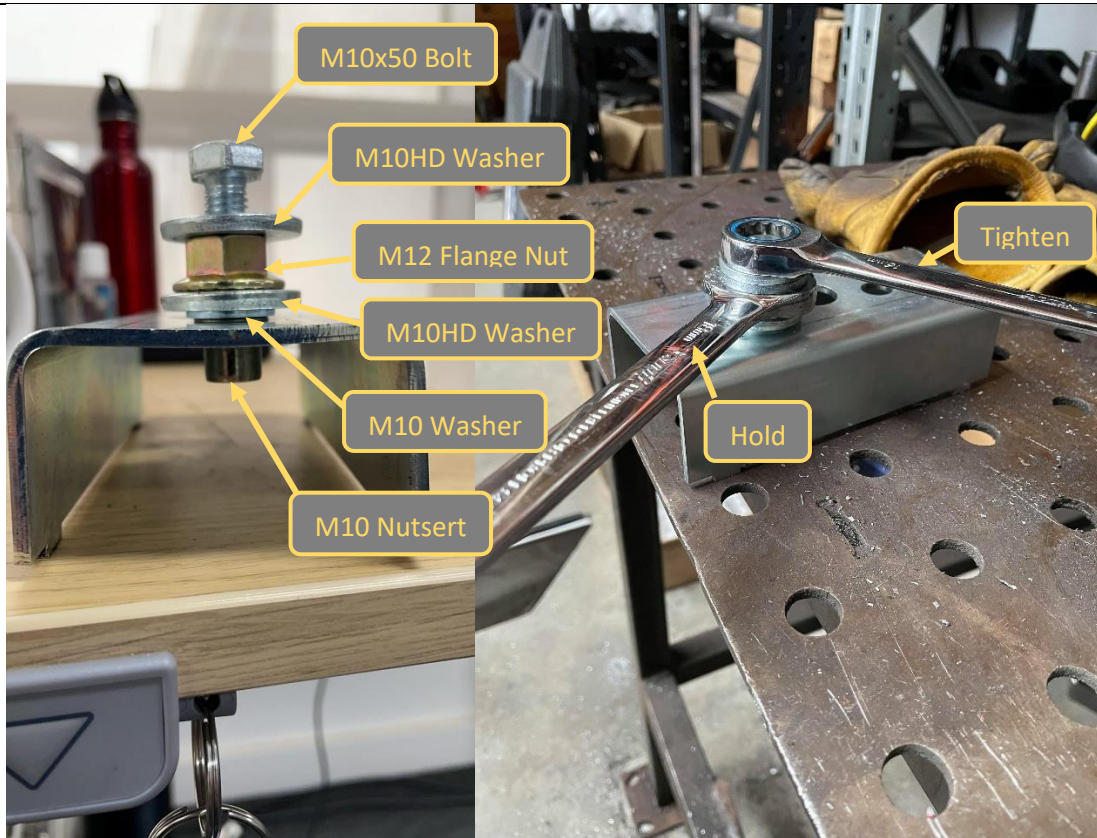

59. Ti-L Models Only

60. Assemble the M10x50 Bolt, M10 HD washers M10 Washer and M12 Flange nut as shown in the image above.

61. Fit the M10 Nutsert onto the end of the threaded section of the M10x50 Bolt.

62. Insert Nutsert into hole in chassis. Whilst holding the M12 Nut with a spanner, tighten the M10x50 bolt to progressively set the Nutsert in the chassis.

63. Take note of the resistance during the tightening and stop once the resistance starts to increase.

TOOLS REQUIRED

16mm Spanner
18mm Spanner

FASTENERS

M10x50 Bolt
M10 HD washer
M12 Flange nuts



64. Loosely fit the Impact mounts to the chassis, As shown. Secure with one factory flange nut on the inside only, finger tight at this stage

TOOLS REQUIRED

FASTENERS
1x Factory Flange Nut

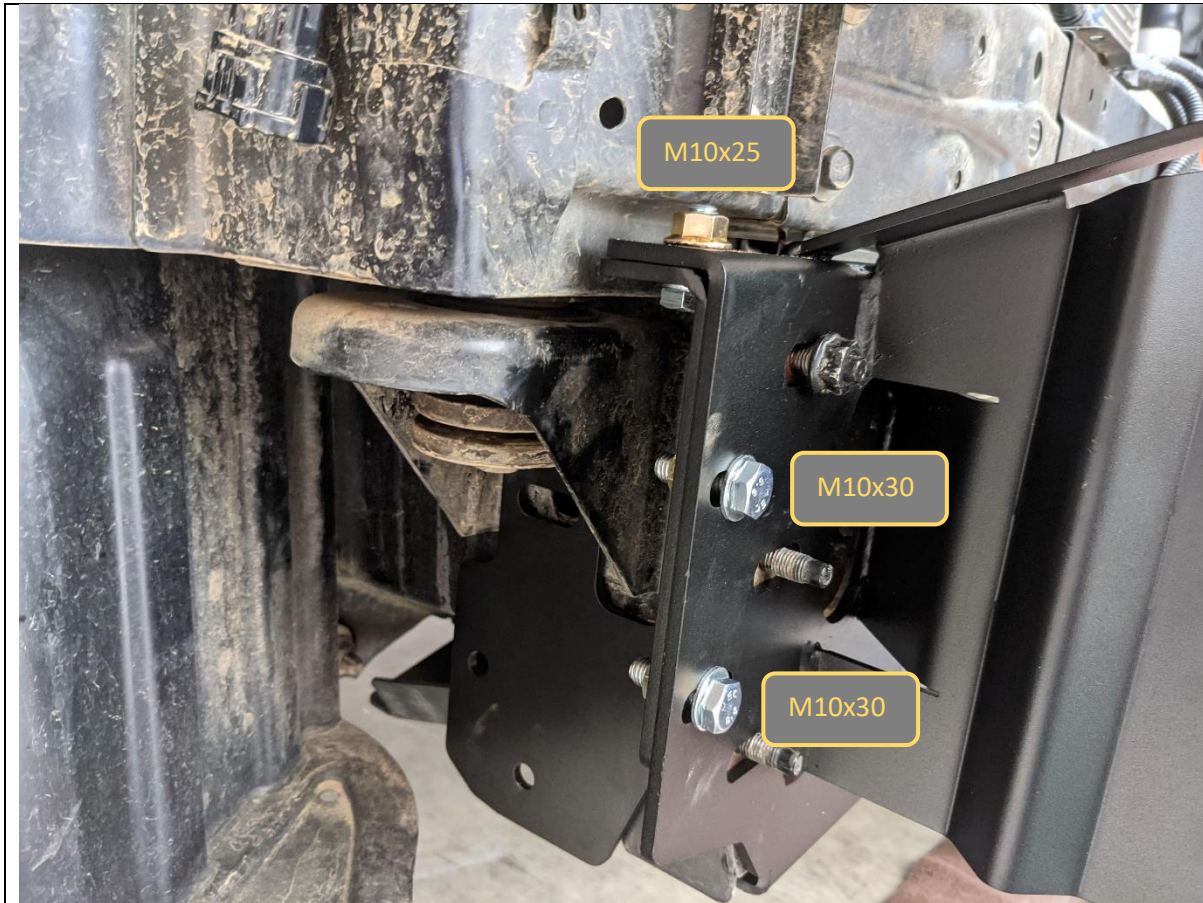

65. Fit the chassis brace behind the chassis end plate and secure with 2x M10x30 (Front) and 1x M10x25 (Top) bolt, flange nut and flat washer as shown.

66. Leave bolts finger tight at this stage.

TOOLS REQUIRED

FASTENERS

2x M10x30 Bolt
1x M10x20 Bolt
3xM10 Flat Washer
3xM10 Flat washers

Per side



- 67. Finally fit the tow point over the top of the impact assembly and chassis brace as shown..
- 68. Fit all the remaining M10 Factory flange bolts now.
- 69. Leave bolts finger tight at this stage.

TOOLS REQUIRED

13,14,16 & 18mm Sockets

FASTENERS

1x M8x30 Hex Bolt
1x M12x40x1.25 Bolt
3x M10x30 Bolt
3xM10 Flat Washer
3xM10 Flat washers

Per side

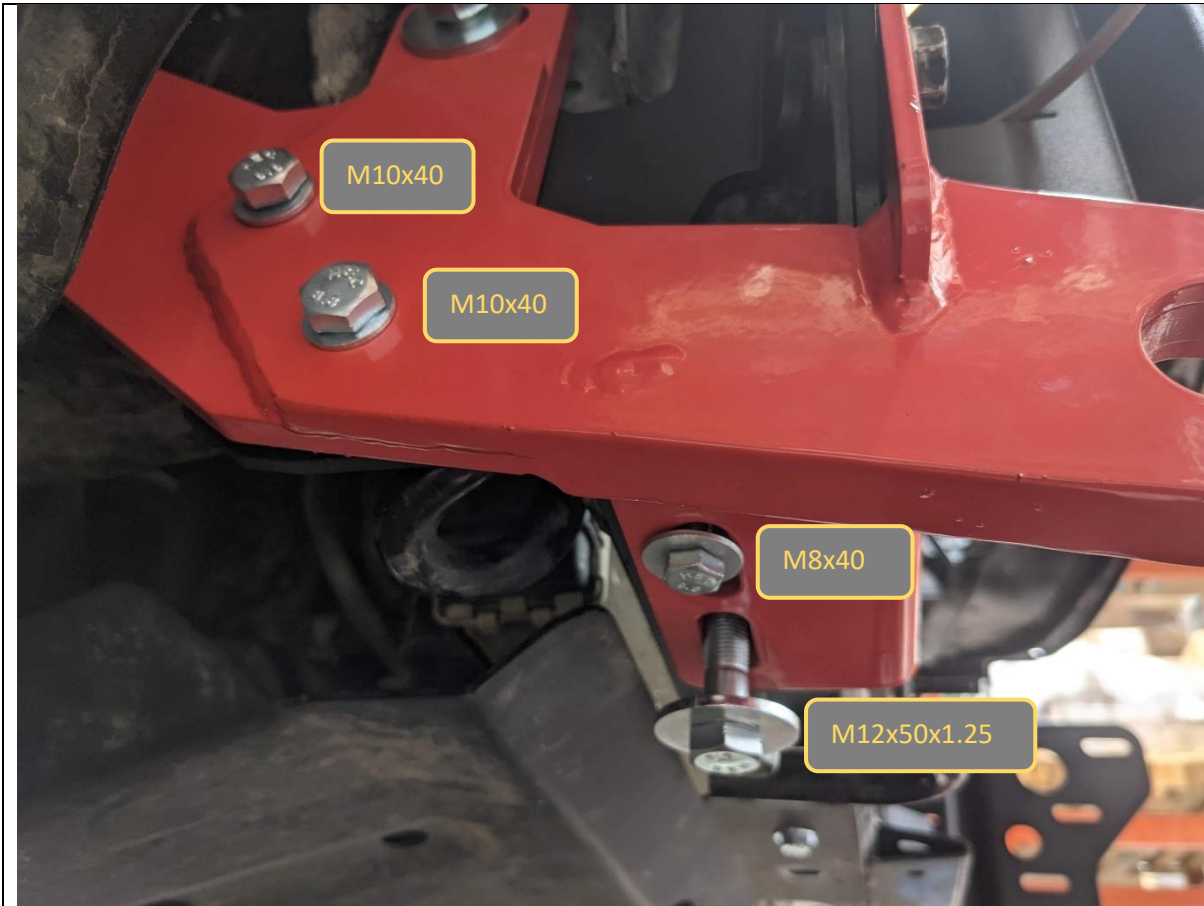

70. Secure the impact assembly and tow point to the chassis and each other using the fasteners shown.

71. Leave bolts finger tight at this stage.

TOOLS REQUIRED

FASTENERS

- 1x M8x40 Hex Bolt
- 1xM8 Flat Washer HD
- 1x M12x50x1.25 Bolt
- 1xM12 Flat washer HD
- 2x M10x40 Bolt
- 2xM10 Flat Washer
- 2xM10 Flange Nut

Per side

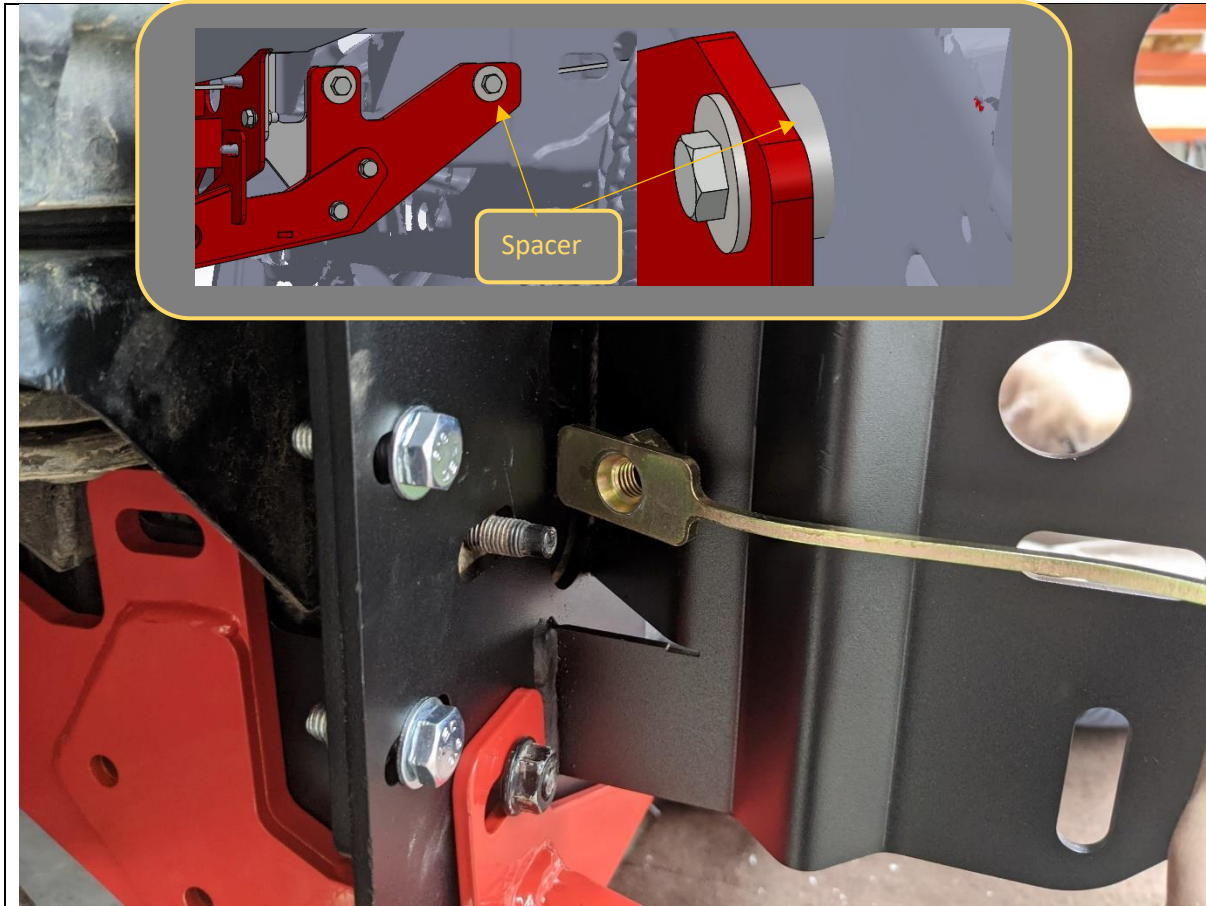

72. Use nut plates and M12x50 Bolts and HD flat washers
Secure the impact assembly and tow point to the
chassis

73. Forward point is accessed through front of chassis rail,
rear point accessed through chassis rail slot in the
wheel arch. The rear point requires the 10mm spacers
between the chassis and tow point as shown.

74. Leave all bolts finger tight at this stage.

TOOLS REQUIRED

FASTENERS

2x M12x50 Bolt
2xM12 Flat Washer HD
2x M12 Nut Plate
1x 10mm Spacer Plate

Per side

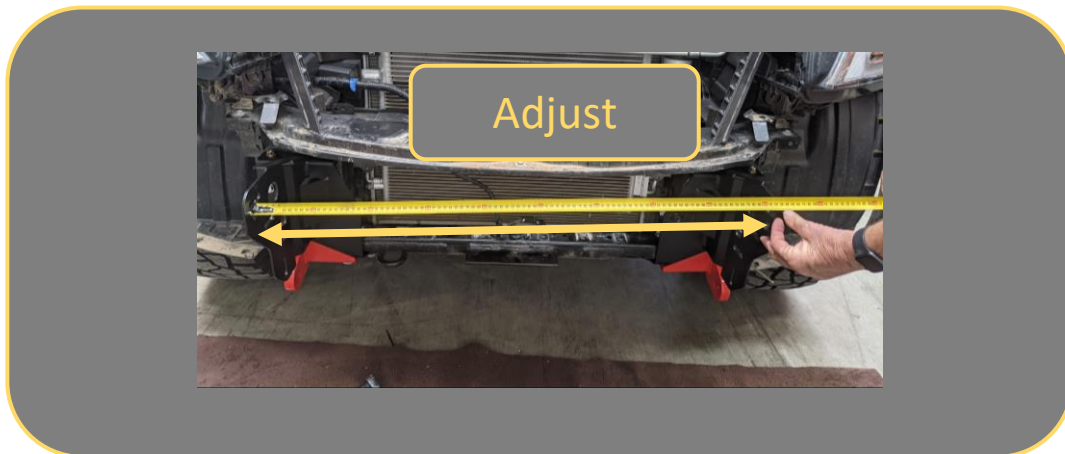
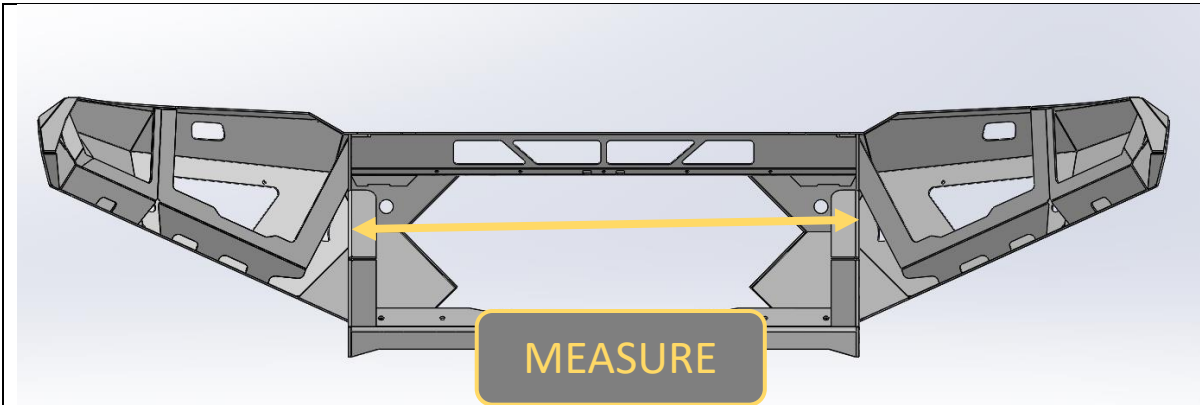

75. Measure Distance between outside edges uprights on bar using tape measure. Write distance below for reference if required.

Bar Upright Width = _____mm

76. Adjust mounts by sliding mounts on slots, such that distance between outside edges of mounts is approximately 2-5mm more than bar.

77. Secure and tighten mounts. Tighten bolts that secure the Impact assembly to chassis first, then tow point to chassis bolts and finally impact assembly to tow point bolts.

TOOLS REQUIRED

TAPE MEASURE
16mm Socket
18mm Socket

FASTENERS



78. Re-Fit Grille to the vehicle, ensuring it is located properly in the push in clips.

TOOLS REQUIRED

FASTENERS



- 79. Re-Fit fog lamps to the Fog light brackets using M6X16 Button head Bolts, Flat washers, and Flange nuts from the Small Parts Kit.
- 80. Secure and tighten using 4mm Allen Key and 10mm Spanner

TOOLS REQUIRED

4mm Allen Key
10mm Spanner / Socket

FASTENERS

3x M6x16 BHCS – Black
3x M6 Flat Washer
3x M6 Flange Nut

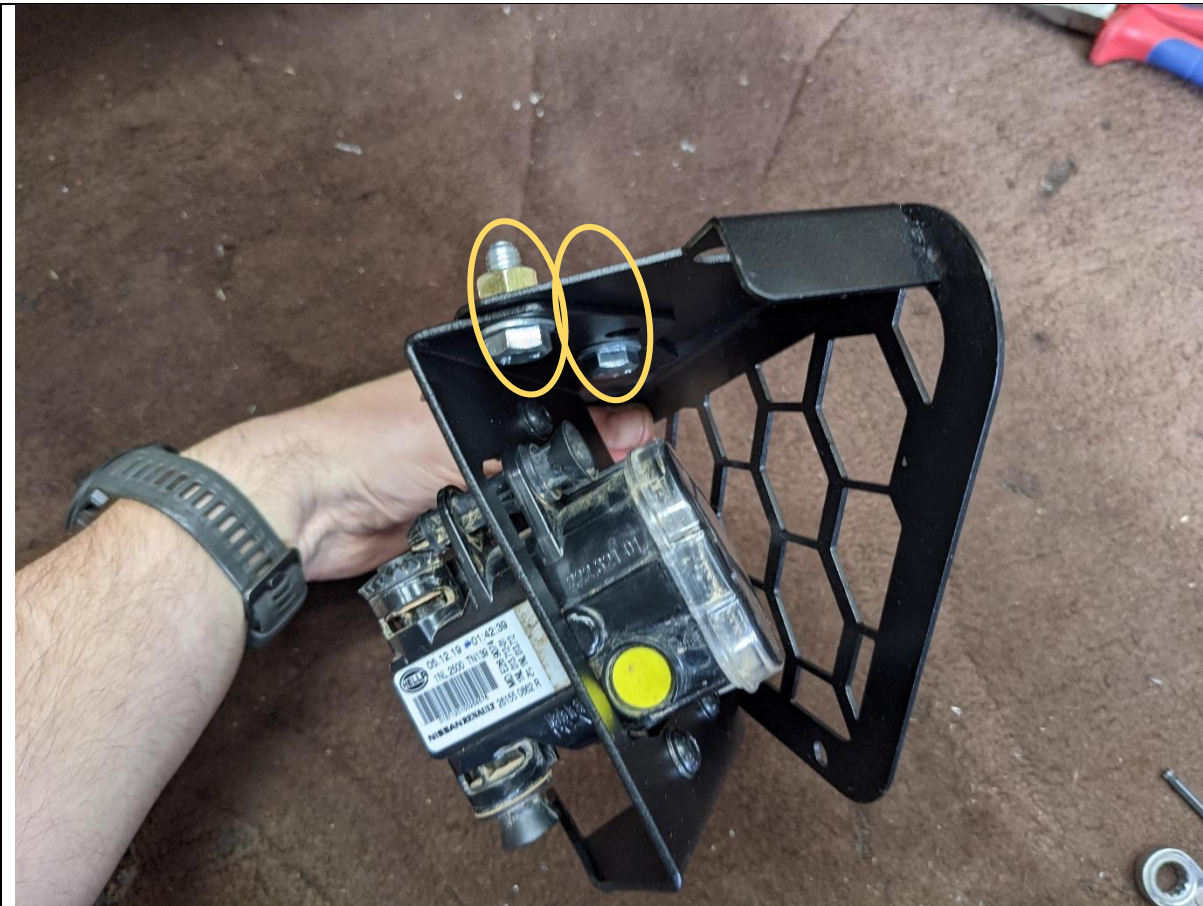

81. Fit fog light bracket, with fog light in place to the Mesh panel using 3x M8x25,
82. Secure and tighten using 13mm Spanner or socket.
83. Repeat for other side of bar.

TOOLS REQUIRED

4mm Allen Key
10mm Spanner / Socket
13mm Spanner / Socket

FASTENERS

3x M8x25 Hex
3x M8 Flat Washer
3x M8 Flange Nut

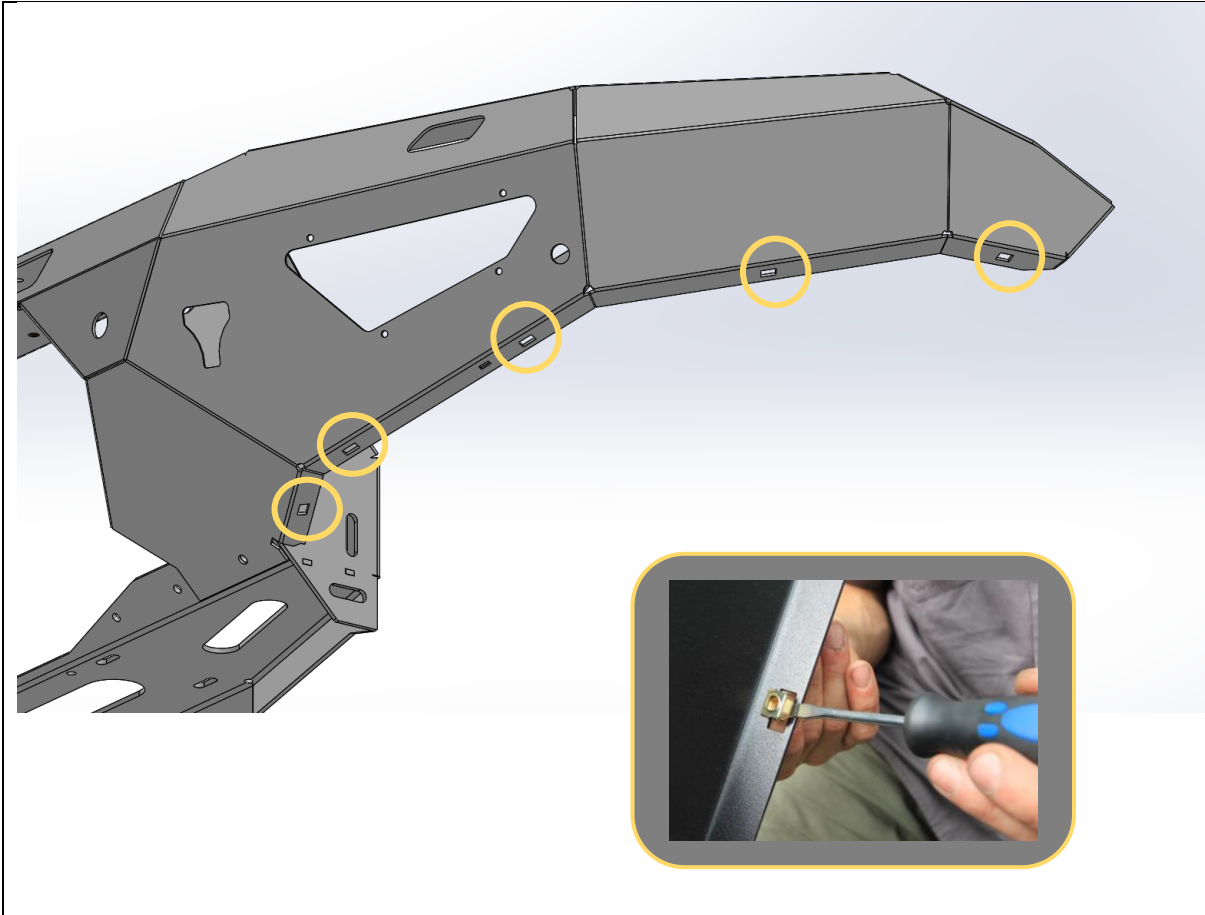

84. Fit 5x Cage nuts from small parts kit to rectangular slots in bottom of wing.
Use a small flat bladed screwdriver to push the edge of the cage to engage with the slot to aid fitting.
85. Repeat for other side of Bar

TOOLS REQUIRED

Small Flat Bladed Screwdriver

FASTENERS

5x M6 Cage Nut
Per side

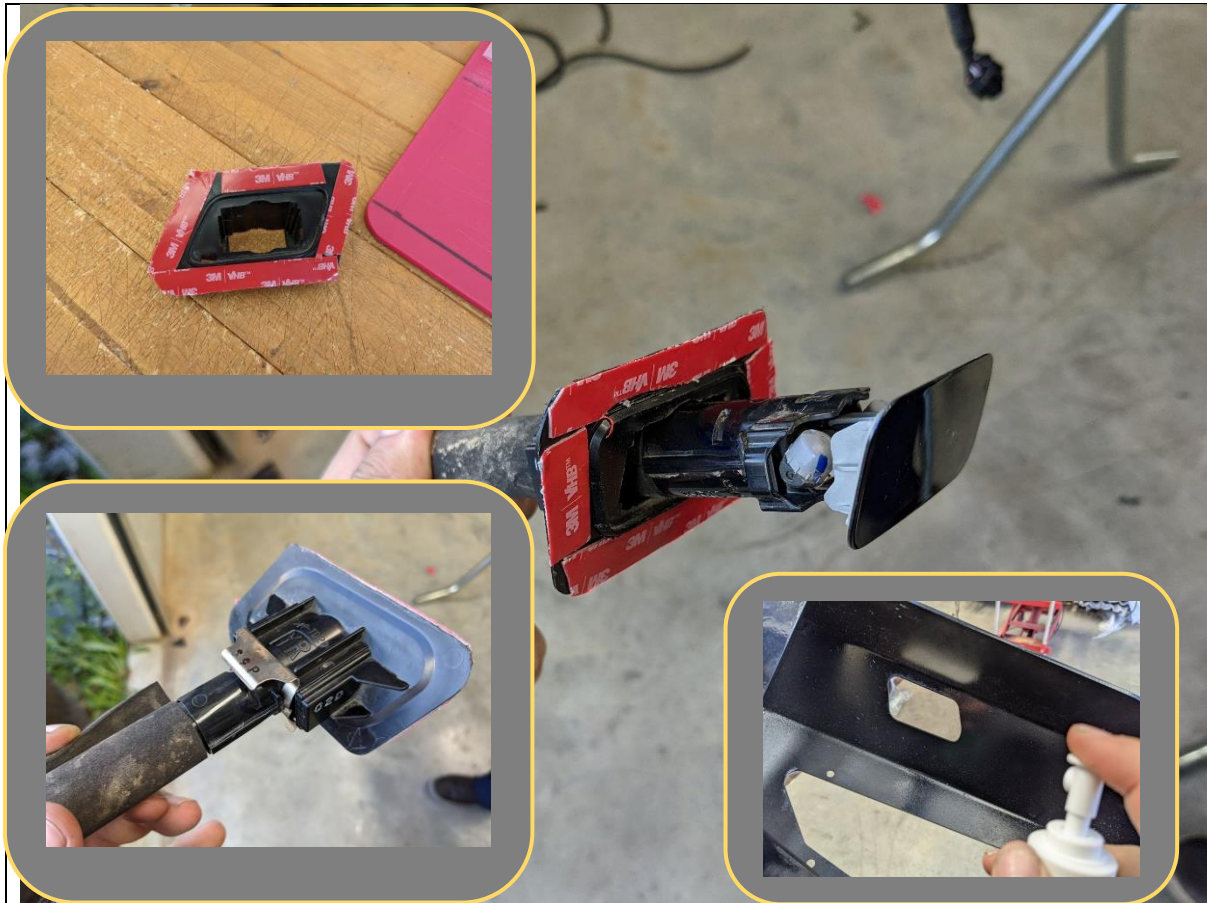

86. Apply VHB automotive grade double sided tape to the headlight washer housings. An automotive grade silicone adhesive can also be used if desired
87. If the bar is not to be colour coded, paint the headlight washer covers black before refitting
88. Refit the washer to the housing, securing with original spring clip.
89. Thoroughly clean the area on the back side of headlight cutout to be bonded with cleaning solvent.

TOOLS REQUIRED

Cleaning Solvent
VHB Tape or Adhesive

FASTENERS



- 90. Carefully align and fit the headlight washer assembly to the bar, from behind.
- 91. If using silicone adhesive, secure in place with tape whilst adhesive cures.
- 92. Complete washer refitment for both sides of bar.

TOOLS REQUIRED

FASTENERS

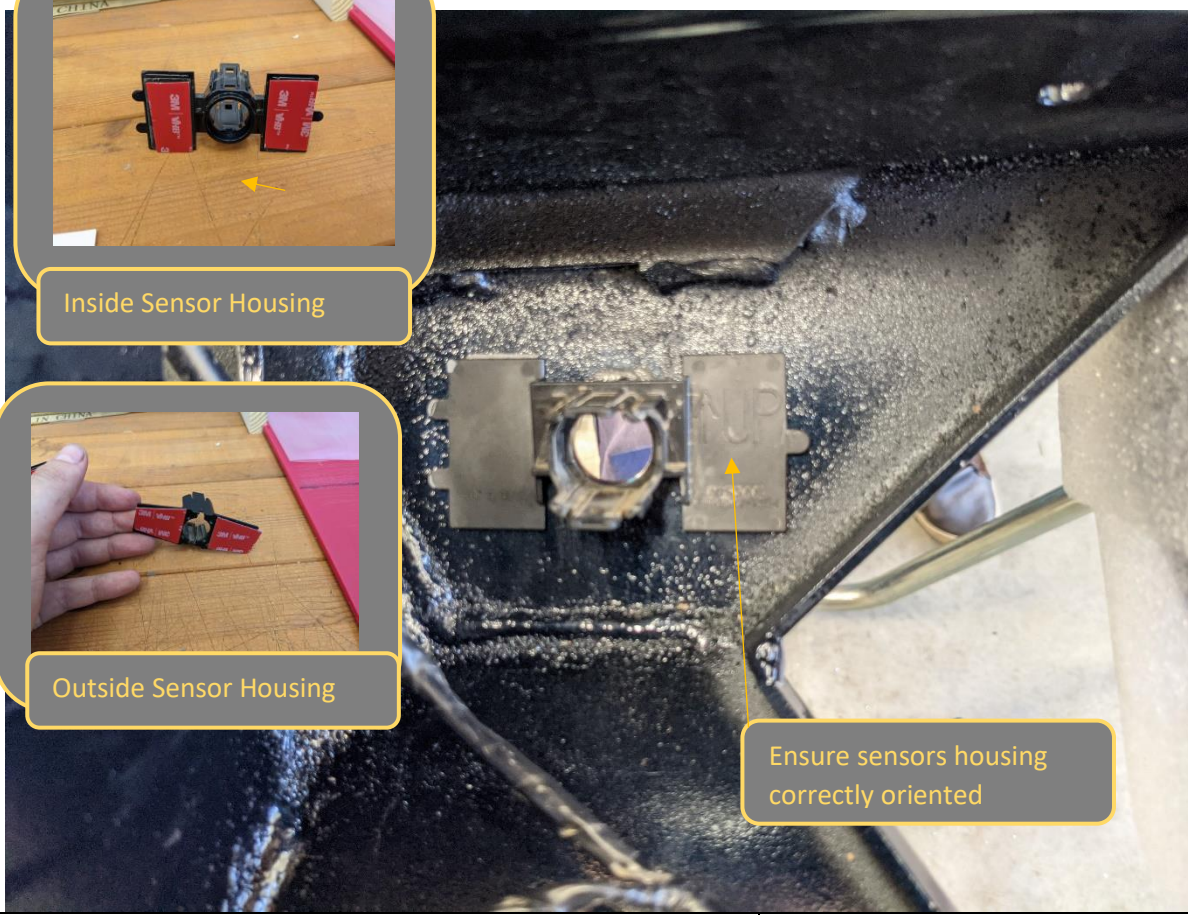
	
<ol style="list-style-type: none"> 93. Re Fit parking sensors to the bar. 94. Clean area on back side of bar adjacent to sensor holes with isopropyl alcohol. 95. Apply a VHB tape to the sensor housing flats. 96. Alternately a silicone adhesive (ORA recommends Sikaflex227) can be used around the hole and glue the sensor housings in place. 97. Regardless of adhesive used re fit housings to original positions. Hold in place with tape until glue sets. 98. Refit sensors to relocated housings once glue has set. 	<p>TOOLS REQUIRED</p> <p>Automotive adhesive VHB Tape Cleaning solvent</p> <hr/> <p>FASTENERS</p>



<p>99. The electrical harness needs to be extended by 450mm</p> <p>100. Extend wires one at a time to ensure connections are not mixed up</p> <p>101. Ensure all connections are appropriately insulated and waterproofed. ORA recommends using self-soldering butt joint connectors.</p>	<p>TOOLS REQUIRED</p> <p>Soldering iron / Heat Gun Electrical Connectors Wire</p>
<p>102. Sensor wires are in twisted pair arrangement. Ensure extension wires for sensor are also twisted in pairs as per factory wires.</p> <p>103. Wrap extension in corrugated tube once complete</p>	<p>FASTENERS</p> <p>Cable Ties</p>



<p>104. Re Fit Extended loom to the bar</p> <p>105. Re connect loom to sensors and fog lights.</p> <p>106. Secure loom to bar with cable ties.</p>	<p>TOOLS REQUIRED</p>
	<p>FASTENERS</p> <p>Cable Ties</p>

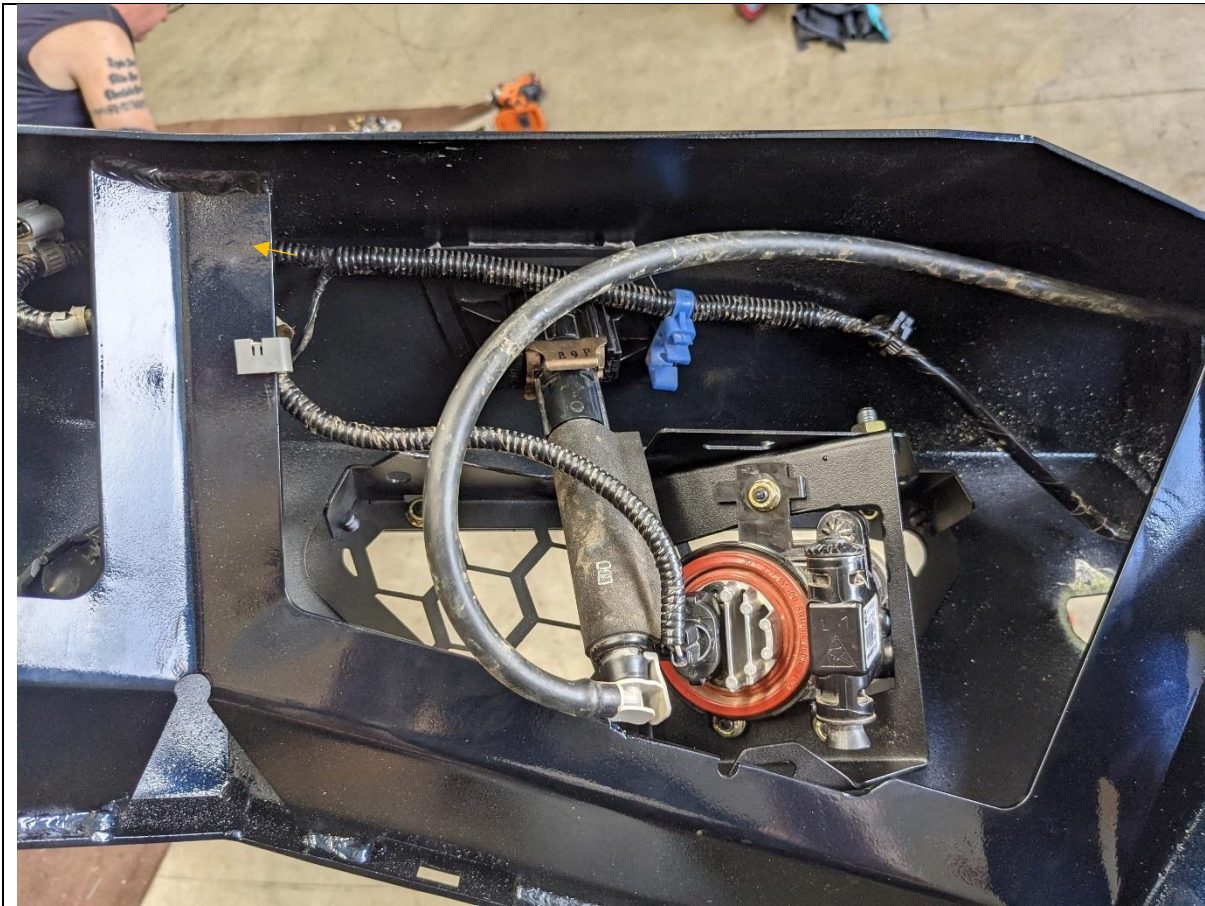

- 107. Fit fog light meshes to the bar, secure with M6x16 Button head bolts, Washers and Flange Nuts
- 108. Re Fit washer tubing to the bar,
- 109. Re connect headlight washers to tubing

TOOLS REQUIRED

4mm Allen Key
10mm Spanner

FASTENERS



<p>110. If Fitting an integrated light bar, do so now.</p> <p>111. The bar is designed to fit an Offroad Animal 22in or STEDI ST3K 21.5 inch light bar. If fitting this light bar, assemble bar with legs inward, and it will line up with the slots in the center gusset. Secure with M8 Fasteners supplied with the light bar.</p>	<p>TOOLS REQUIRED</p> <p>13mm Spanner / Socket</p>
<p>112. The bar can accommodate most other “20 inch” size light bars.</p> <p>113. If fitting driving lights to the bar this is also the most convenient time to do so</p> <p>114. Once lights are fitted, fit the Pan brace between the pan and gusset using the supplied M6 Fasteners</p>	<p>FASTENERS</p> <p>Supplied with Light Bar</p> <p>2xM6x16 Button Head 1xM6X12 Button Head 3x M6 Flat Washer 3x M6 Flange Nut</p>



115. With assistance, either from another person, or a lifting trolley, lift the bar onto the mounts on the vehicle.
116. Secure with 4x M12x30 Bolts, Heavy Duty washers and 2xM12 Nyloc Nuts and 2x M12 Flange nuts per side, Finger tight at this stage.

TOOLS REQUIRED

Lifting Trolley

FASTENERS

8x M12x30 Bolt
12x M12 Heavy Duty Large Washer
4x M12 Nyloc Nut
4x M12 Flange Nut



117. With assistance, from another person, Align the bar with the edges of the vehicle. Adjust such that the clearances are neat and even side to side.

Acceptable range of clearances shown in image above.

118. Once in position tighten the M12 Bolts using socket and spanner. An impact driver may be used to speed up this process.

TOOLS REQUIRED

Lifting Trolley
19mm Socket and Spanner

FASTENERS



- 119. If Fitting a winch, do so now.
- 120. The bar is designed to fit most low mount winches, in foot down configuration.
- 121. If control box is to be mounted on top of winch Modification of the upper cross bar as mentioned in Step 18 will be required.
- 122. Ensure clutch handle will be accessible through access hole in front mesh panel. Refer to winch instructions regarding changing clutch handle location.

TOOLS REQUIRED

Refer to winch fitting instructions

FASTENERS

Supplied with winch



123. If Required, Fit winch fairlead to Mesh Fairlead Mount. Use M10 or 3/8" Fasteners supplied with winch. The bar is only compatible with Hawse type fairleads.

124. Fit the Radar module to the radar bracket supplied using M6x16 Button head bolts, Flat washers and Flange nuts.

125. Fit the module in the bracket to the mesh panel using M6x16 Button head bolts, Flat washers and Flange nuts. Ensure that the plastic radar cover plate sits between the radar bracket and the mesh panel as shown

126. Fit the Mesh Fairlead Mount to the center of the bar, using M8x16 Button head (Top), M8x20 Hex (Bottom) M8 Flat washers and M8 Flange Nuts (Bottom Only).

127. Tighten fasteners using 13mm socket / spanner and 5mm Allen Wrench.

128. Fit Number plate flip kit to fairlead mount, using fasteners supplied in kit.

TOOLS REQUIRED

13mm Spanner
5mm Allen Wrench

FASTENERS

2x M8x16 Button Head
2x M8x20 Hex Head
2x M8 Flange Nut
4xM8 Flat Washer

7xM6x16 Button Head
7xM6 Flat Washer
7x M6 Flange Nut

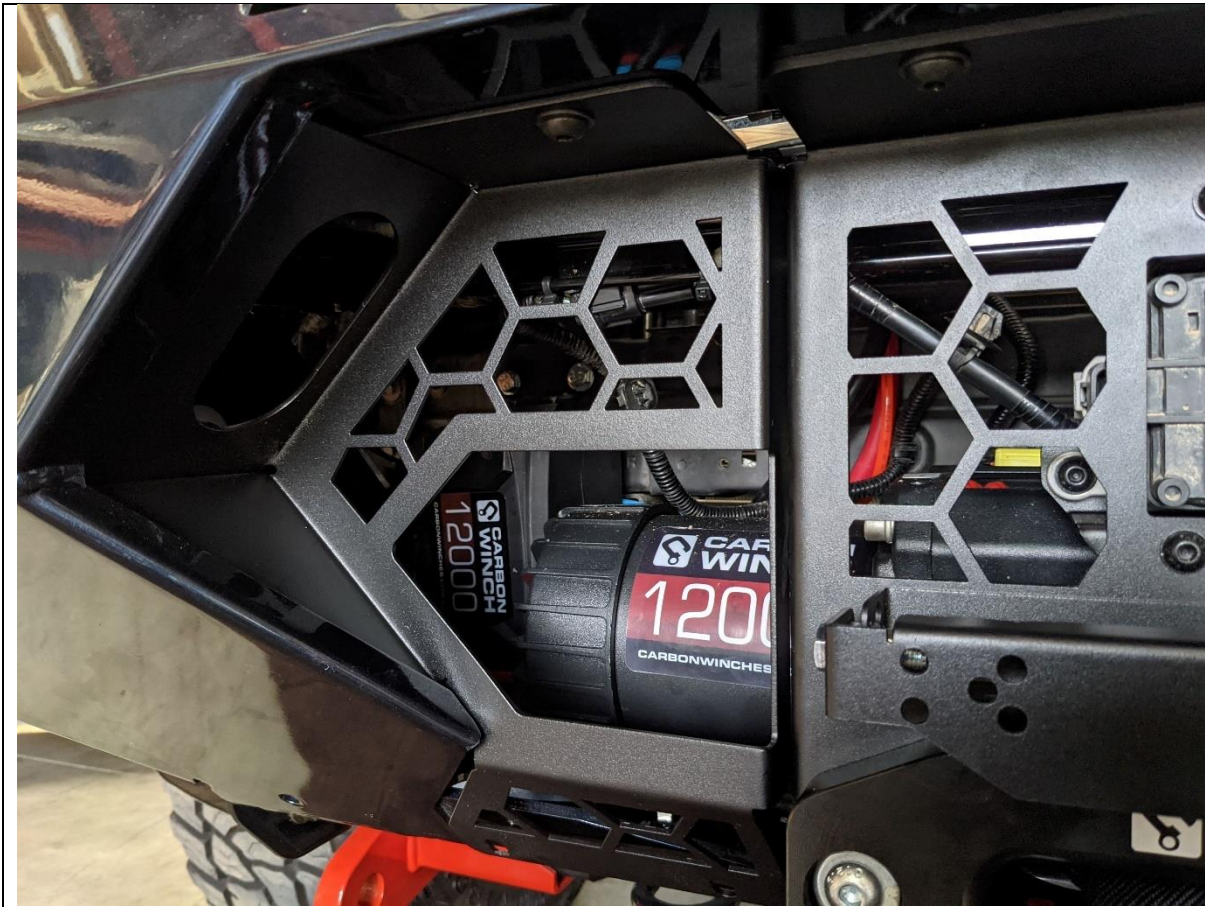

129. Fit Mesh Infill Panels. Use M8x16 Button head bolt, M8 flat washer into the captive thread in the bullbar. The side edges of the mesh panel fit behind the flange on the bar
130. Don't fit any bolts to bottom holes at this stage.
131. Tighten top fasteners using 13mm socket / spanner and 5mm Allen Wrench.

TOOLS REQUIRED

13mm Spanner
5mm Allen Wrench
 10mm Spanner
4mm Allen Wrench

FASTENERS

2x M8x16 Button Head
 2xM8 Flat Washer



132. Re Connect Electrical Harness and fog lights. Make Sure to also reconnect Radar and Camera harnesses.

133. Replace upper radiator cowl using original clips.

TOOLS REQUIRED

FASTENERS

Factory clips (re-use)



134. Remove the first section of headlight washer hose from the T piece adjacent to the RHS washer.
135. Use side cutters to cut the clamp securing the connector and remove connector from the hose.
136. Re fit connector to extended hose provided.

TOOLS REQUIRED

Flat Screwdriver
Side Cutters

FASTENERS

Hose clamps



137. Re fit extended hose assembly to T piece and secure ends with hose clamps provided.

138. Reconnect Headlight washer connectors.

TOOLS REQUIRED

FASTENERS



139. Before fitment of bash plate remove lower M12x50 Fine Pitch bolt from chassis thread.

140. Fit Center Bash Plate using, M8x30 button head, flat washer and flange nut to front face. Ensure these fasteners pass through the side mesh panels also.

141. Secure back of Center Bash Plate (U-0030) using the M12x50 Fine Pitch bolt from removed before.

142. Tighten Bottom fasteners using 18mm Socket

143. Tighten front fasteners using 13mm socket / spanner and 5mm Allen Wrench. Reach through access hole in mesh panel to reach nut.

TOOLS REQUIRED

10, 13 mm Spanner
5 mm Allen Wrench
18mm Socket

FASTENERS

6x M8x20 Button Head
6x M8 Flange Nut
6xM8 Flat Washer



144. Fit Side Under panels using, M6x16 button head and flat washer into the cage nuts placed earlier.
145. Tighten with 4mm Allen wrench
146. Secure back of side under panel to mount using M8x20 Hex Bolt, Flat washer and M8 Flange Nut.
147. Leave finger Tight at this stage

TOOLS REQUIRED

FASTENERS

- 10x M6x16 Button Head
- 10x M6 Flat Washer
- 2x M8x25 Hex Head
- 2x M8 Flange Nut
- 2x M8 Flat Washer



- 148. Using the edge of the under panel as a guide mark the wheel arch liner, approximately 15mm beyond the intersection of the under panel.
- 149. Cut along line as marked using utility Knife
- 150. Tuck the wheel arch liner behind the flange on the under panel
- 151. Tighten all under panel bolts
- 152. Complete for other side of vehicle.

TOOLS REQUIRED
Utility Knife
13mm Spanner
5mm Allen Wrench
4mm Allen Wrench

FASTENERS



153. Fit the Offroad Animal Logo plate to the front face of the bar.
154. Fit the Compliance plate to the underside of bash plate, in location where accessible if required.

TOOLS REQUIRED

FASTENERS

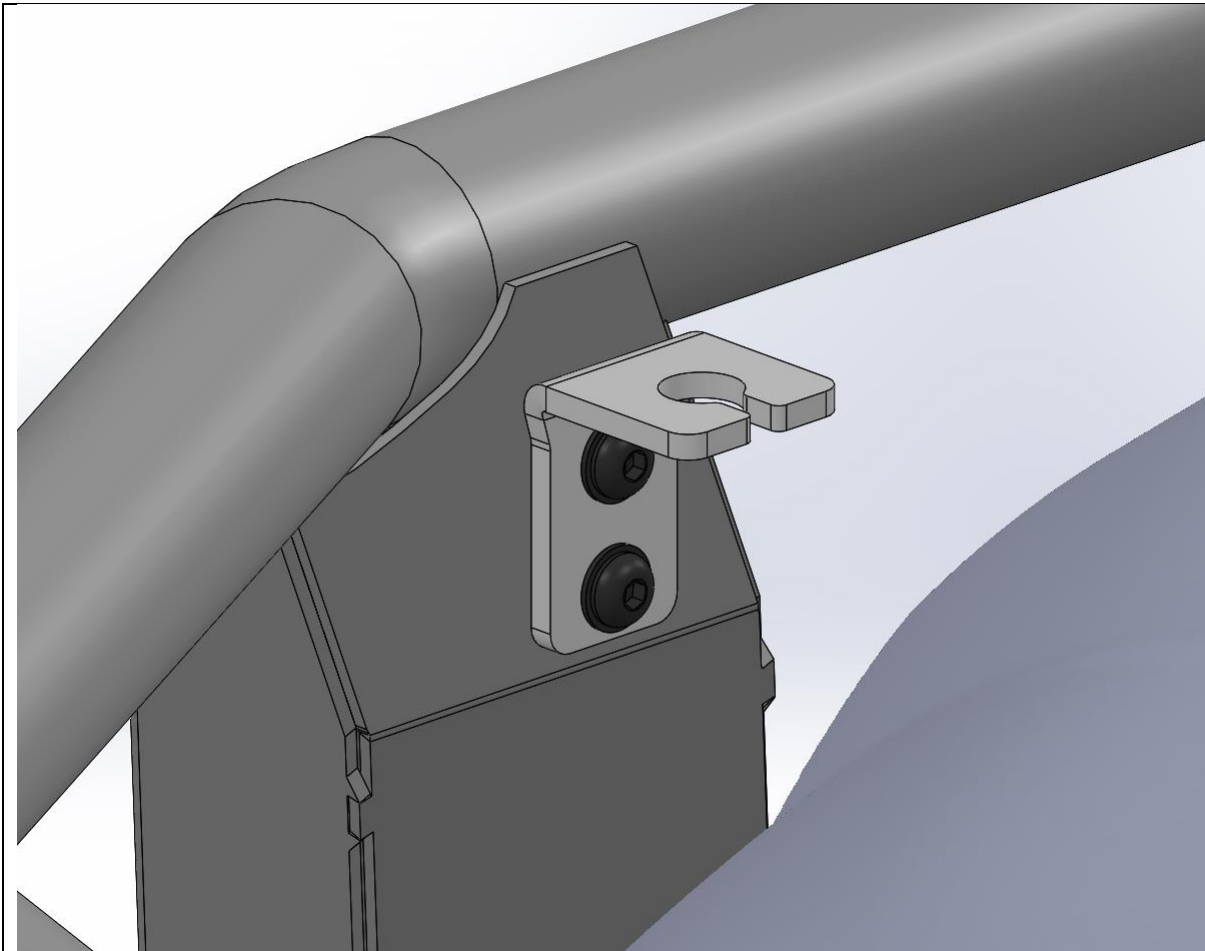

<p>155. If fitting antenna to Toro bar, fit the antenna brackets to the M8 Threaded inserts in the uprights..</p> <p>156. Tighten with 5mm Allen wrench</p> <p>157. Fit Antenna to the bracket as per antenna manufacturer's instructions</p> <p>158. Retain unused brackets for future use.</p>	<p>TOOLS REQUIRED</p> <p>5MM Allen Key</p>
	<p>FASTENERS</p> <p>2x M8x20 Button Head Screw 2x M8 Black Flat Washer</p>



159. Check all Fasteners are tight.
160. Re-Fit number plate to number plate flip.
161. Head Bush and Enjoy your newly protected Patrol!

For contact details see www.offroadanimal.com.au