



## CHEVROLET SILVERADO 1500 LTZ 4<sup>th</sup> Gen 2023+ Predator & Toro Front Bar Fitting Instruction







### **IMPORTANT! – READ BEFORE INSTALLATION**

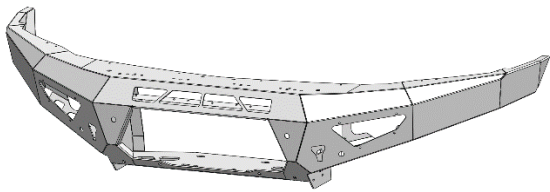
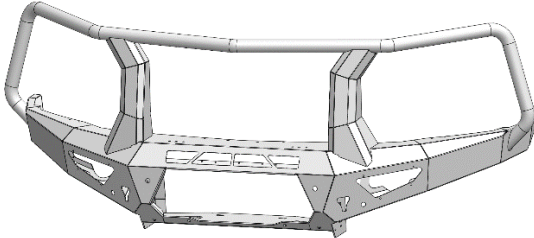

- When installed in accordance with these instructions, the front protection bar does not affect the operation of the vehicles SRS airbags.
- This product must be installed exactly as per these instructions using only hardware supplied.
- Take a few moments to read instructions thoroughly before beginning work.
- In the event of damage to any bar component please contact OFFROAD ANIMAL to arrange repair/replacement of components.
- Do not use this product for any vehicle make or model other than that specified on these instructions.
- Do not remove labels from this product.
- This product and its fixings must not be modified in any way unless stated in these fitting instructions.
- The installation of this product is recommended for trained personnel.
- These instructions are correct at time of publication. OFFROAD ANIMAL cannot be held responsible for the impact of any changes subsequently made by the vehicle manufacturer. If you find something has changed, please contact us to let us know!
- During installation it is the duty of the installer to check correct operation/clearances of all components.
- If Instructions are to be printed for reference in the workshop, it is recommended that they are printed in colour, for best legibility.

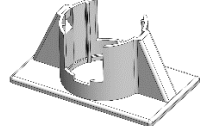
# PARTS LISTING

**IMPORTANT:** Check all parts are present before beginning work! Contact OFFROAD ANIMAL if something is missing.



## Parts – In the Main Box

Qty	Part Number	Description	Image
1	FB-S15-T1-23-PR-ASM1	Silverado 1500 Predator Bar Welded Assembly	
<b>OR</b>			
1	FB-S15-T1-23-TOR-ASM1	Silverado 1500 Toro Bar Welded Assembly	
4	CPHP029	Plastic Hole Insert, 17.4MM, Black, Tigerlink Hardware CPHP029	
4	F-0015	Chevrolet/Jeep Sensor Holder – Straight	
1	FB-S15-T1-20-PR-ADRCP	ADR Compliance Plate Silverado 1500	
1	OFA-LOGO	Offroad Animal Metal Logo	
2	PWS-TOP-600	Pinch Weld PWS51T – Top Bulb Seal 600mm	

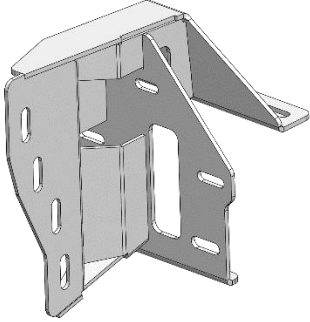
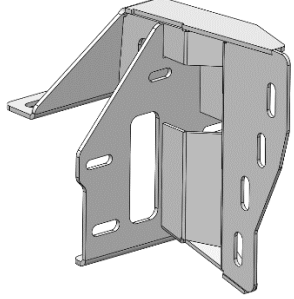
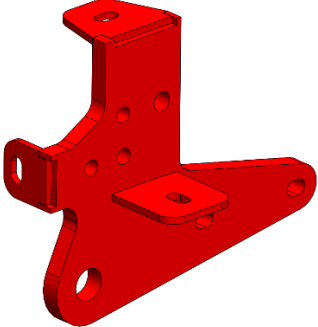

1	TK-COM-PSEN-4	Tape Kit – 4 Sensor Universal	
6	TK-FB-FRA-NG-22	Tape Kit – Next Gen Ranger Front Bar	

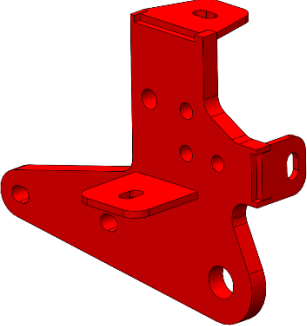
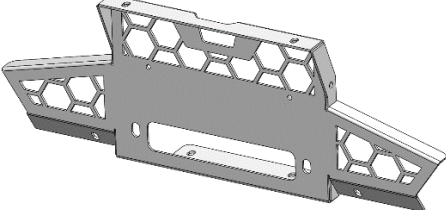
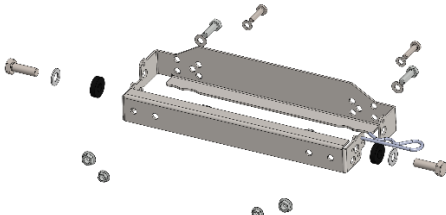
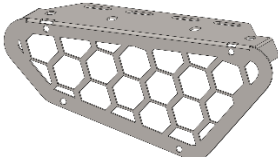
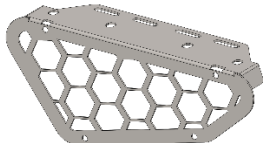
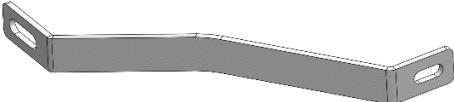
### Parts – In the Fitting Kit Box

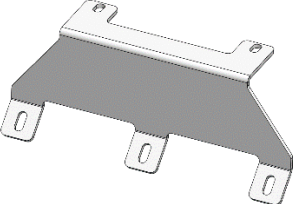
Qty	Part Number	Description	Image
1	FB-S15-T1-20-PR-ASM2R	Silverado 1500 Impact Assembly	
1	FB-S15-T1-20-PR-ASM2L	Silverado 1500 Impact Assembly	
1	FB-S15-T1-20-PR-ASM3R	Silverado 1500 Tow Point Assy	

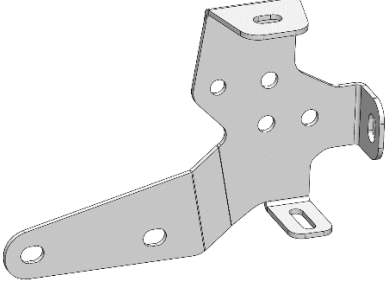
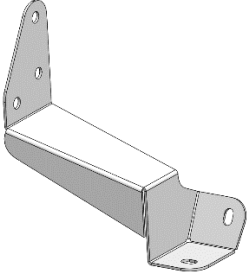
<p><b>1</b></p>	<p>FB-S15-T1-20-PR-ASM3L</p>	<p>Silverado 1500 Tow Point Assy</p>	
<p><b>1</b></p>	<p>FB-S15-T1-20-PR-ASM4</p>	<p>Silverado 1500 Mesh Fairlead Assy</p>	
<p><b>1</b></p>	<p>NPF-COM-SM-ASM0</p>	<p>Number Plate Flip ASM Small</p>	
<p><b>1</b></p>	<p>M-0002R</p>	<p>Light Cover Mesh</p>	
<p><b>1</b></p>	<p>M-0002L</p>	<p>Light Cover Mesh</p>	
<p><b>1</b></p>	<p>B-0857R</p>	<p>Silverado 1500 Winch Strap</p>	
<p><b>1</b></p>	<p>B-0857L</p>	<p>Silverado 1500 Winch Strap</p>	
<p><b>1</b></p>	<p>B-0858</p>	<p>Silverado 1500 Pan Brace</p>	

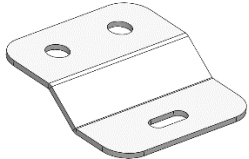
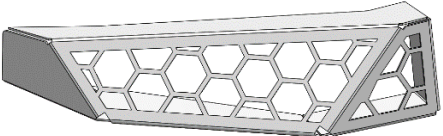
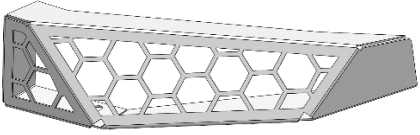
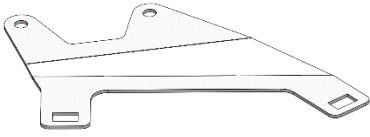
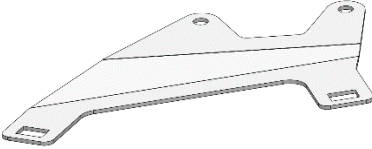
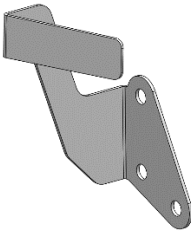
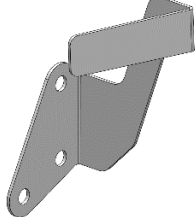
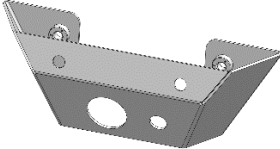
<p><b>1</b></p>	<p>B-0861R</p>	<p>Silverado 1500 Halo Fog Light Bracket</p>	
<p><b>1</b></p>	<p>B-0861L</p>	<p>Silverado 1500 Halo Fog Light Bracket</p>	
<p><b>1</b></p>	<p>B-0862R</p>	<p>Silverado 1500 Front Mount Chassis Brace</p>	
<p><b>1</b></p>	<p>B-0862L</p>	<p>Silverado 1500 Front Mount Chassis Brace</p>	
<p><b>1</b></p>	<p>B-0866R</p>	<p>Silverado 1500 Headlight Bracket</p>	
<p><b>1</b></p>	<p>B-0866L</p>	<p>Silverado 1500 Headlight Bracket</p>	

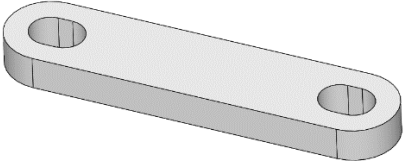
2	B-0867	Silverado 1500 Side Underpanel Mount Bracket	
1	B-0940R	Facelift Headlight Infill	
1	B-0940L	Facelift Headlight Infill	
1	B-0941R	Facelift Headlight Infill Support Bracket	
1	B-0941L	Facelift Headlight Infill Support Bracket	
1	B-0942R	Bumper Winglet Support	
1	B-0942L	Bumper Winglet Support	
1	B-0943	Facelift Camera Housing	
6	P-0024	Ranger Tow Point Spacer	
2	P-0278	Silverado 1500 Tow Point Rear Spacer Plate	

<p><b>1</b></p>	<p>U-0064R</p>	<p>Silverado 1500 Side Underpanel</p>	
<p><b>1</b></p>	<p>U-0064L</p>	<p>Silverado 1500 Side Underpanel</p>	
<p><b>1</b></p>	<p>U-0065</p>	<p>Silverado 1500 Bash Plate</p>	
<p><b>1</b></p>	<p>U-0066</p>	<p>Silverado 1500 Lower Base Plate</p>	
<p><b>TORO BAR ONLY</b></p>			
<p><b>2</b></p>	<p>B-0649</p>	<p>Toro Antenna Bracket – 90 Degree Tall</p>	

**PREDATOR Fasteners – Contained in Small Parts Kit Bag**

Qty	Part Number	Description
8	M4x12 PAN	SCREW, PAN HEAD PHILLIPS, M4X12X0.7 GR4.6 ZP
8	M4 FLAT WASHER	Flat Washer M4, 8mmODx0.8mm T
8	M4 FLANGE NUT	Flange Nut, M4
4	M5X15 BHCS BZP	SCREW, BUTTON HEAD CAP, M5X15X0.8 GR12.9 ISO4042 ZnNi BLACK PASSIVATED FINISH
4	M5 Flat washer	M5 FW
4	M5 Flat washer BZP	M5 Flat Washer, 10x5.3x1, ISO4042 ZnNi BLACK PASSIVATED FINISH
2	M5 FLANGE NUT	Flange Nut, M5x0.8 G8.8 ZP
4	M6 X 12 HEX	M6X12 HEX BOLT, ZP, 8.8
3	M6 X 20 HEX	M6X20 HEX BOLT, ZP, 8.8
27	M6x16 BHCS BLACK ZINC	SCREW, BUTTON HEAD CAP, M6X16X1 GR12.9, ISO4042 ZnNi BLACK PASSIVATED FINISH
7	M6 FLAT WASHER	M6 FW
27	M6 FLAT WASHER BLACK ZINC	M6 Flat Washer, 12x6.1x1, ISO4042 ZnNi BLACK PASSIVATED FINISH
20	M6 FLANGE NUT	Flange Nut, M6x1 G8.8 ZP
14	M6CN3MM	CAGE NUT M6x2.6-3.5
4	M8 X 12 HEX	Bolt Hex, M8X12x1.25, GR8.8 ZP
4	M8 X 20 HEX	Bolt Hex, M8X20x1.25, GR8.8 ZP
4	M8 X 16 BHCS BZP	SCREW, BUTTON HEAD CAP, M8X16X1.25 GR12.9, ISO4042 ZnNi BLACK PASSIVATED FINISH
4	M8 X 20 BHCS BLACK ZINC	SCREW, BUTTON HEAD CAP, M8X20X1.25, ISO4042 ZnNi BLACK PASSIVATED FINISH
6	M8 FLAT WASHER	M8 FW
2	M8 HD FLAT WASHER	M8 FLAT WASHER - High Tensile 19x8x1.9mm
8	M8 FLAT WASHER - BLACK ZINC	M8 FLAT WASHER, 16.5x8.4x1.2, ISO4042 ZnNi BLACK PASSIVATED FINISH
6	M8 FLANGE NUT	Flange Nut, M8x1.25 G8.8 ZP
4	M10 x 25	Bolt Hex, M10X25x[1.5], GR8.8 ZP
4	M10 FW LHD	WASHER, FLAT M10X28.5X2.5
4	M10 FLANGE NUT	Flange Nut, M10x1.5 G8.8 ZP
16	M12X30	Bolt Hex, M12X30x1.75, GR8.8 ZP
6	M12X120	Bolt Hex, M12X120x1.75, GR8.8 ZP
4	M12X130	Bolt Hex, M12X130x1.75, GR8.8 ZP
28	M12 FW LHD	M12 FW Large Heavy Duty
24	M12 FLANGE NUT	Flange Nut, M12x1.75 G8.8 ZP
2	M12 Nyloc nut	M12 NYLOC NUT
4	T-0060	Silverado 1500 Crush Tube 75mm
2	T-0061	Silverado 1500 Crush Tube 95mm
2	NP-COM-M8-200-ASM0	M8 Nut Plate 200mm
2	NP-COM-M10-190-SLIM	Nut Plate M10 Slim - Suit DMAX Predator
2	NP-COM-M12-300- ASM0	M12 NUT PLATE 300MM STEM



**TORO Fasteners – Contained in Small Parts Kit Bag**

Qty	Part Number	Description
8	M4x12 PAN	SCREW, PAN HEAD PHILLIPS, M4X12X0.7 GR4.6 ZP
8	M4 FLAT WASHER	Flat Washer M4, 8mmODx0.8mm T
8	M4 FLANGE NUT	Flange Nut, M4
4	M5X15 BHCS BZP	SCREW, BUTTON HEAD CAP, M5X15X0.8 GR12.9 ISO4042 ZnNi BLACK PASSIVATED FINISH
4	M5 Flat washer	M5 FW
4	M5 Flat washer BZP	M5 Flat Washer, 10x5.3x1, ISO4042 ZnNi BLACK PASSIVATED FINISH
2	M5 FLANGE NUT	Flange Nut, M5x0.8 G8.8 ZP
4	M6 X 12 HEX	M6X12 HEX BOLT, ZP, 8.8
3	M6 X 20 HEX	M6X20 HEX BOLT, ZP, 8.8
27	M6x16 BHCS BLACK ZINC	SCREW, BUTTON HEAD CAP, M6X16X1 GR12.9, ISO4042 ZnNi BLACK PASSIVATED FINISH
7	M6 FLAT WASHER	M6 FW
27	M6 FLAT WASHER BLACK ZINC	M6 Flat Washer, 12x6.1x1, ISO4042 ZnNi BLACK PASSIVATED FINISH
20	M6 FLANGE NUT	Flange Nut, M6x1 G8.8 ZP
14	M6CN3MM	CAGE NUT M6x2.6-3.5
4	M8 X 12 HEX	Bolt Hex, M8X12x1.25, GR8.8 ZP
4	M8 X 20 HEX	Bolt Hex, M8X20x1.25, GR8.8 ZP
4	M8 X 16 BHCS BZP	SCREW, BUTTON HEAD CAP, M8X16X1.25 GR12.9, ISO4042 ZnNi BLACK PASSIVATED FINISH
8	M8 X 20 BHCS BLACK ZINC	SCREW, BUTTON HEAD CAP, M8X20X1.25, ISO4042 ZnNi BLACK PASSIVATED FINISH
6	M8 FLAT WASHER	M8 FW
2	M8 HD FLAT WASHER	M8 FLAT WASHER - High Tensile 19x8x1.9mm
12	M8 FLAT WASHER - BLACK ZINC	M8 FLAT WASHER, 16.5x8.4x1.2, ISO4042 ZnNi BLACK PASSIVATED FINISH
6	M8 FLANGE NUT	Flange Nut, M8x1.25 G8.8 ZP
4	M10 x 25	Bolt Hex, M10X25x[1.5], GR8.8 ZP
4	M10 FW LHD	WASHER, FLAT M10X28.5X2.5
4	M10 FLANGE NUT	Flange Nut, M10x1.5 G8.8 ZP
16	M12X30	Bolt Hex, M12X30x1.75, GR8.8 ZP
6	M12X120	Bolt Hex, M12X120x1.75, GR8.8 ZP
4	M12X130	Bolt Hex, M12X130x1.75, GR8.8 ZP
28	M12 FW LHD	M12 FW Large Heavy Duty
24	M12 FLANGE NUT	Flange Nut, M12x1.75 G8.8 ZP
2	M12 Nyloc nut	M12 NYLOC NUT
4	T-0060	Silverado 1500 Crush Tube 75mm
2	T-0061	Silverado 1500 Crush Tube 95mm
2	NP-COM-M8-200-ASM0	M8 Nut Plate 200mm
2	NP-COM-M10-190-SLIM	Nut Plate M10 Slim - Suit DMAX Predator
2	NP-COM-M12-300- ASM0	M12 NUT PLATE 300MM STEM

## TOOLS REQUIRED

The following tools will be required to install the product.

<b>Hand Tools</b>	<b>Power Tools</b>	<b>Workshop Equipment</b>
Metric Socket Set 7-19mm	Electric/Air Impact Driver (Optional)	Isopropyl Alcohol
Socket Extension Bar	Air Hacksaw	Rag
Metric Spanner Set 7-19mm	or	Cable Ties
Hex (Allen) Key Set 4-6mm	Oscillating Multi Tool	Masking Tape
Torx Key Set	or	Marker Pen
Trim Removal Tool	Angle Grinder	Ruler
Plastic Auto Trim Tool Set	or	Sandpaper
Flat Blade Screwdriver Set	Jigsaw	Automotive adhesive sealant (eg. Sikaflex)
Phillips Head Screwdriver Set		
Utility Knife		
Side Cutters		
Pliers		

# WORKSHOP SAFETY

It is the responsibility of the installer to always complete works in a safe manner. Make sure the following safety equipment is available and precautions are observed whilst fitting this product.

<p>Hearing Protection</p> 	<p>Always wear ear protection when using power tools.</p>
<p>Eye Protection</p> 	<p>Ensure eye protection is always worn when cutting or drilling.</p>
<p>Manual Handling</p> 	<p>Do not attempt to lift bar assemblies or rock sliders on your own.</p> <p>Always use two people to lift or use mechanical Lifting aid such as hydraulic lifting trolley.</p>
<p>Vehicle Support</p> 	<p>Always ensure vehicle is properly supported when working on it. Do not attempt to fit products whilst suspension work is being carried out. Do not work under a vehicle supported only by a jack.</p>



1. Apply masking tape to the plastic bumper on each side, in the approximate location, as shown.

**TOOLS REQUIRED**

Masking tape

**FASTENERS**



2. Mark out a straight horizontal line on the plastic bumper with a ruler, as shown.
3. At the front near the headlight, measure 60mm down from where the straight vertical section begins after the curved corner (red dashed line).
4. At the rear, measure from the intersection point between the bumper and quarter panel, to a point on the bumper along the wheel arch, 190mm away.
5. Repeat on the other side.

**TOOLS REQUIRED**

Marker pen  
Ruler

**FASTENERS**



6. Remove 5x T15 Torx screws securing the wheel arch liner to the bumper.
7. Repeat for the other side.

**TOOLS REQUIRED**

T15 Torx driver

**FASTENERS**

10x T15 Torx screw

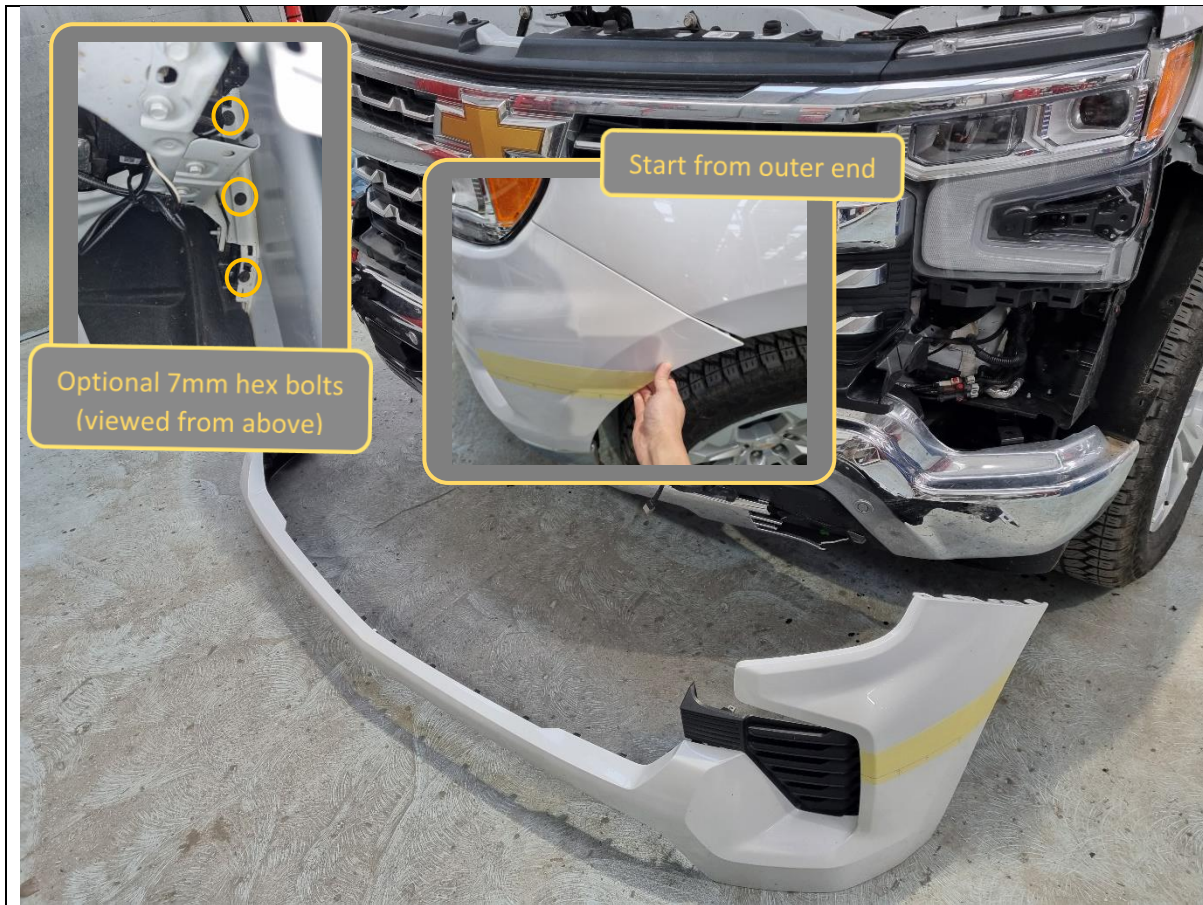

<p>8. With assistance from another person, start from either end of the plastic bumper and pull outwards to release the clips securing to the vehicle.</p> <p>You can also optionally loosen 3x 7mm hex bolts holding the internal bumper clip to help release the bumper. Access from above in the engine bay, down to the quarter panel edge.</p>	<p><b>TOOLS REQUIRED</b></p> <p>7mm socket/spanner (optional)</p>
<p>9. Work your way inwards and continue to release the clips holding the middle section.</p> <p>10. Fully remove the plastic bumper and set aside in a safe place.</p>	<p><b>FASTENERS</b></p>



11. Open the bonnet.

12. Remove the bonnet release handle by unscrewing the 2x T15 Torx screws.

**TOOLS REQUIRED**

T15 Torx Driver

**FASTENERS**

2x T15 Torx screw

Retain for re-assembly



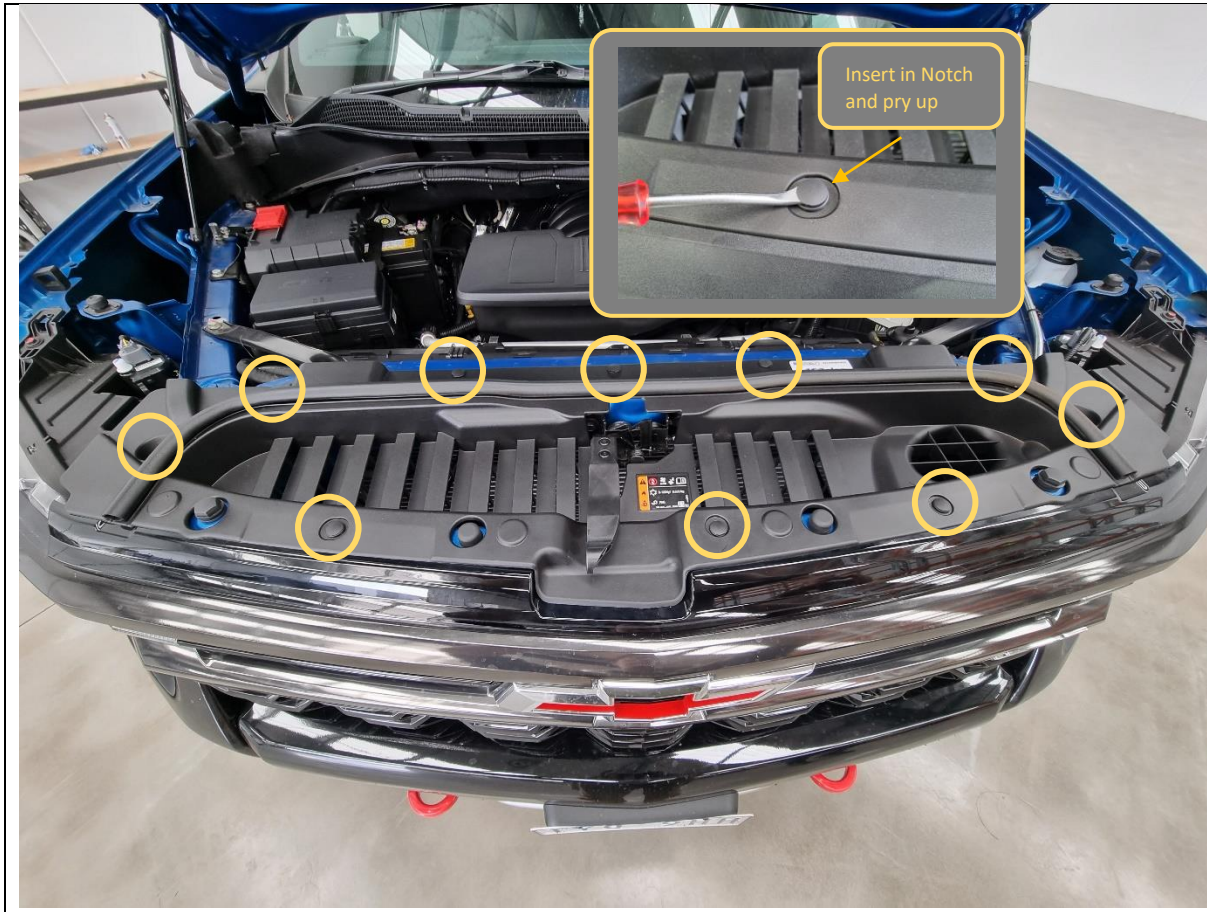

13. Remove 10x plastic push rivets securing the radiator grille cover, by levering centre section upwards using flat bladed screwdriver or trim tool, as shown.

**TOOLS REQUIRED**

Flat blade screwdriver  
or  
Trim tool

**FASTENERS**

10x Plastic push rivet  
  
Retain for re-assembly

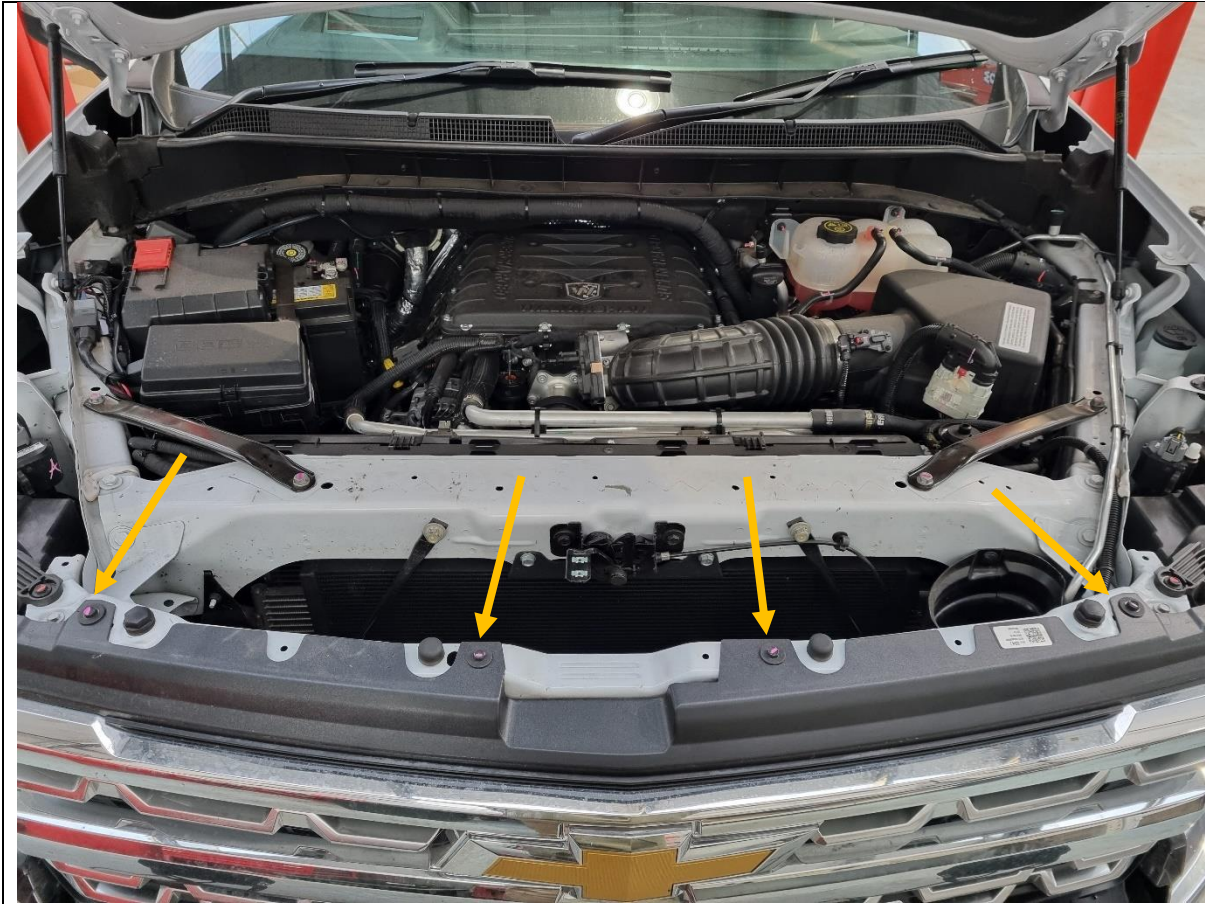

14. Remove 4x 10mm hex bolts on the top edge of the grille.

**TOOLS REQUIRED**

10mm socket/spanner

**FASTENERS**

4x 10mm hex bolt

Retain for re-assembly

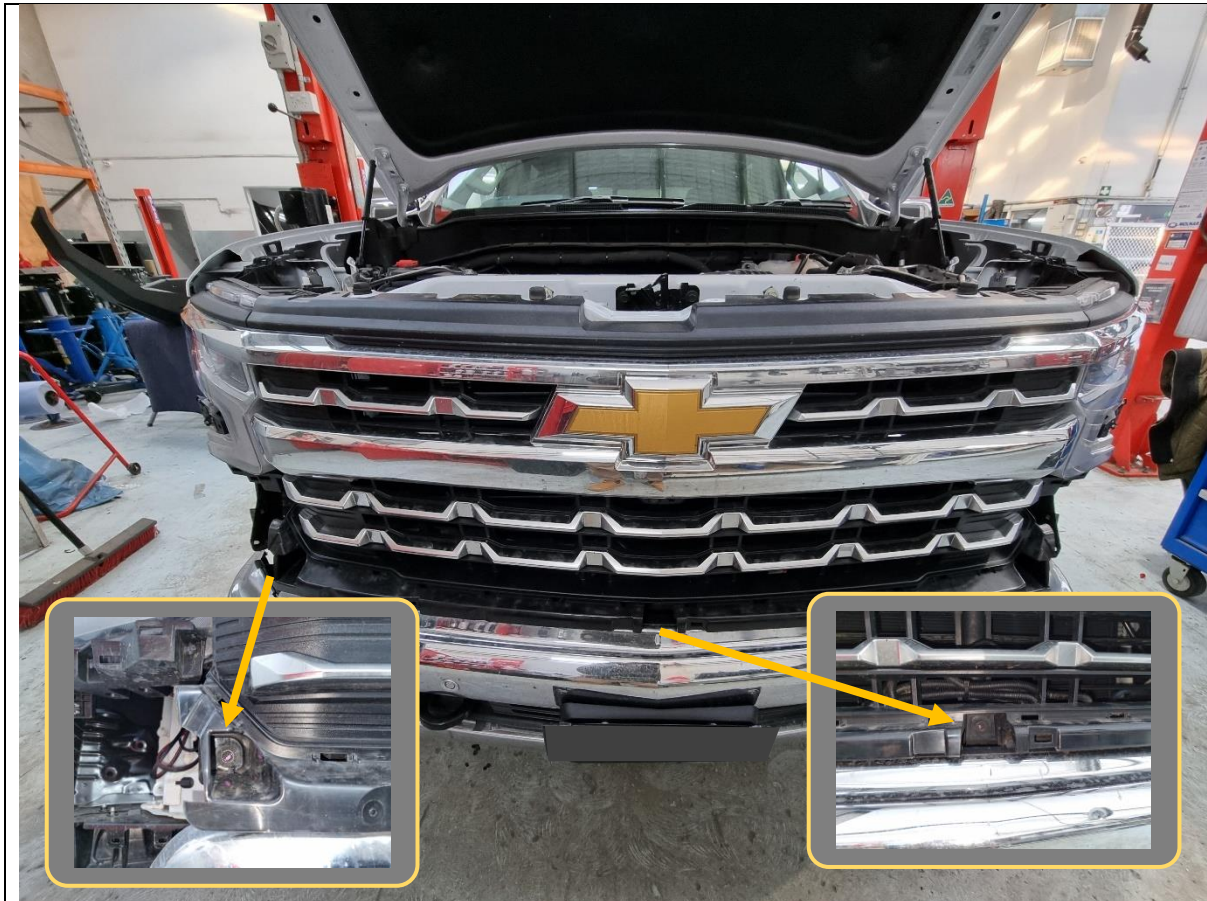

15. Remove 3x 10mm hex bolts along the bottom of the grille.  
2x on each end and 1x in the middle.

A socket extension bar is needed to reach.

**TOOLS REQUIRED**

10mm socket  
Socket extension bar

**FASTENERS**

3x 10mm hex bolt  
Retain for re-assembly

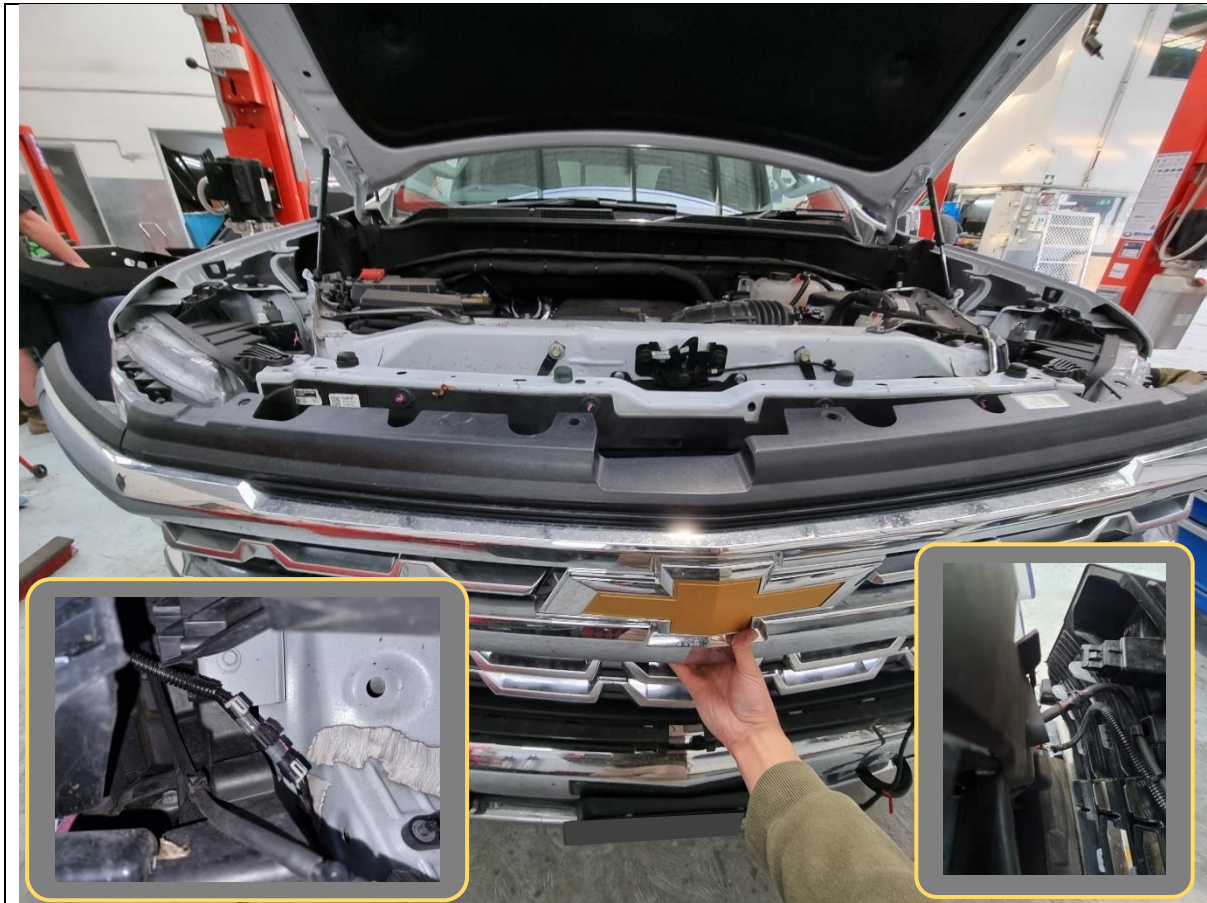

16. Pull the grille outwards to reveal the harness connections on the LH side near the headlight.
17. Disconnect the coaxial camera cable and washer hose for the camera. It is recommended to clamp the rubber washer hose to prevent fluid spillage.
18. Once all cables are disconnected, fully remove the grille and set aside.

**TOOLS REQUIRED**

**FASTENERS**



19. Lift the plastic bumper shroud up to reveal plastic push rivets underneath.
20. Remove 7x plastic push rivets securing the shroud, by levering centre section upwards using flat bladed screwdriver or trim tool.

**TOOLS REQUIRED**

Flat blade screwdriver  
or  
Trim tool

**FASTENERS**

7x Plastic push rivet

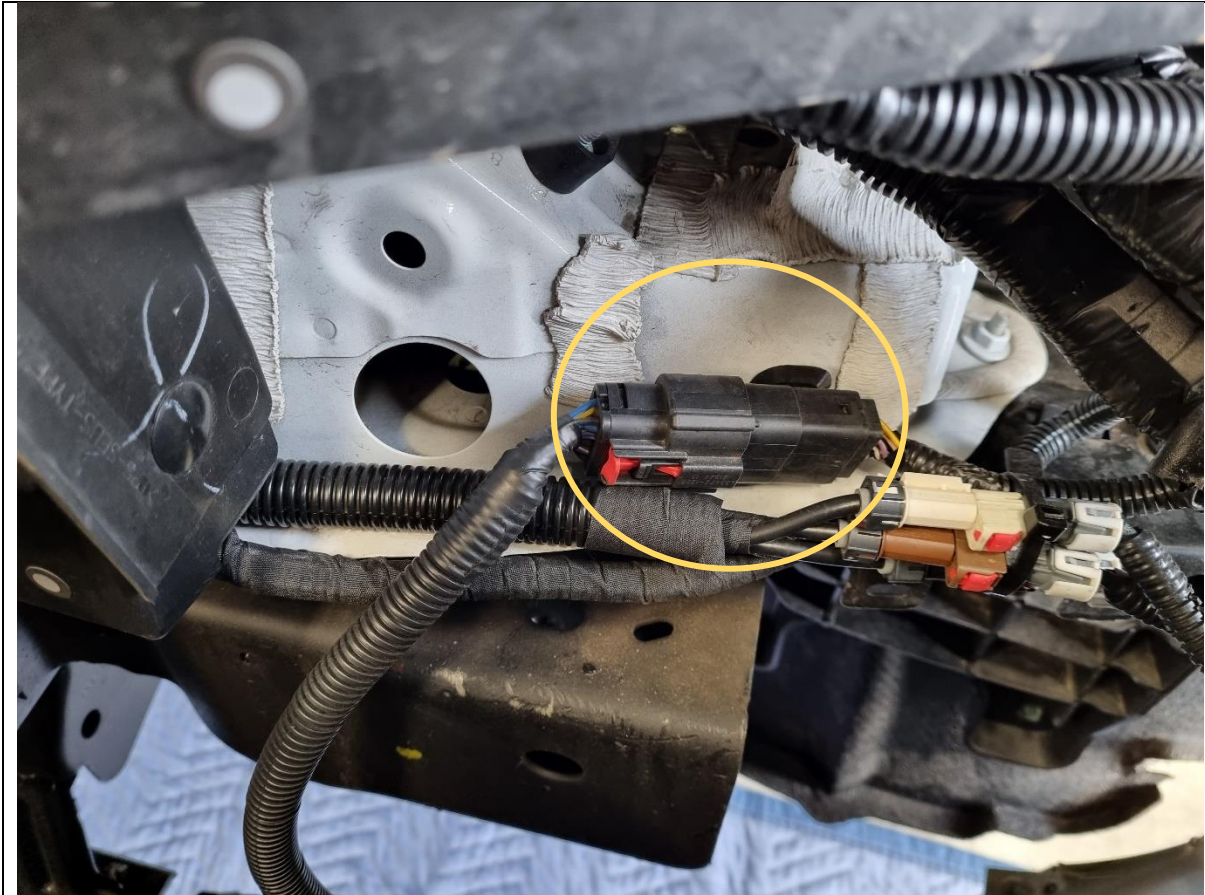

21. On the LH passenger side under the headlight, disconnect the main bumper harness connector.

**TOOLS REQUIRED**

**FASTENERS**



- 22. Remove 4x 18mm hex bolts along the top of the steel bumper, where the plastic bumper shroud was.
- 23. Use a socket extension bar or reach in with a spanner to access the lower bolts.

**TOOLS REQUIRED**

18mm socket/spanner  
Socket extension bar

**FASTENERS**

4x 18mm hex bolt

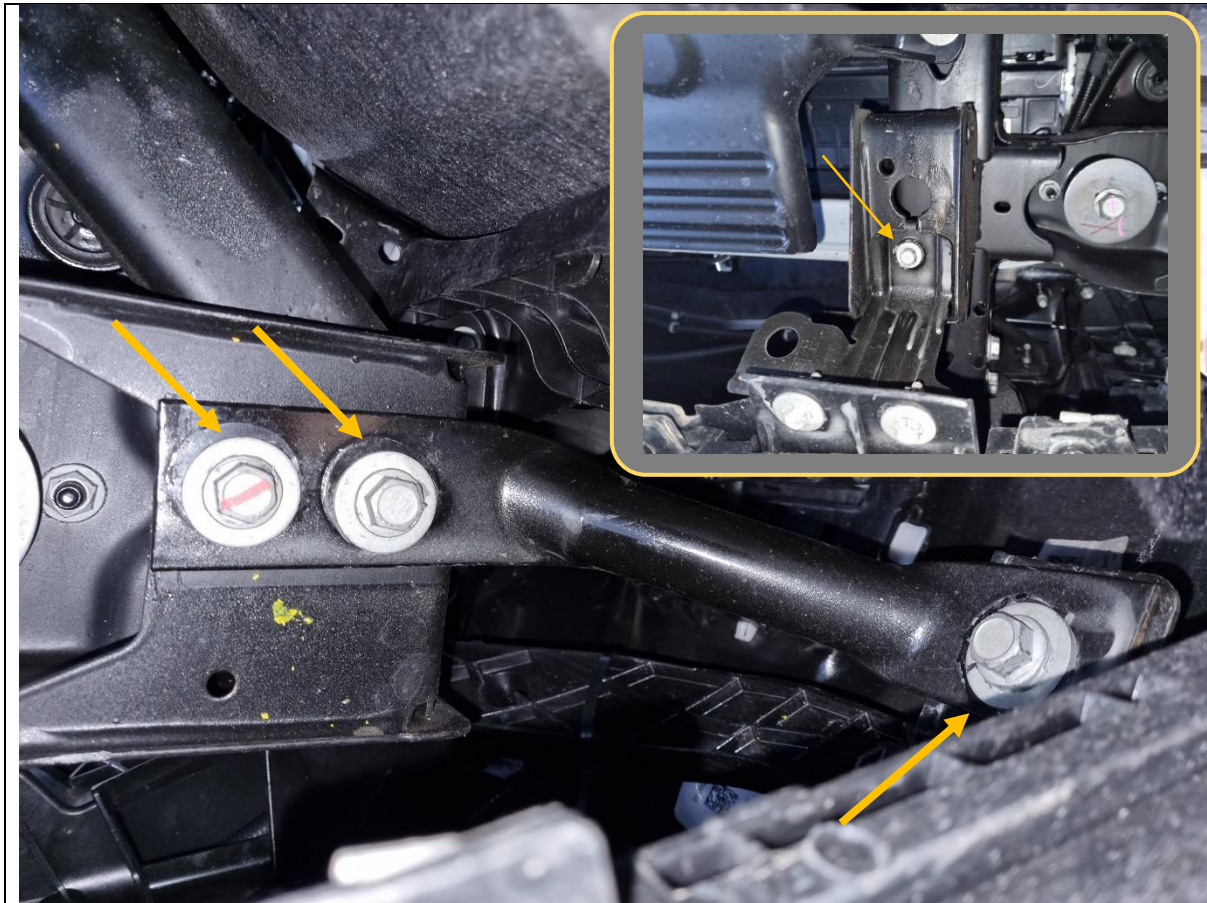

24. From underneath the vehicle, remove the 3x 15mm hex bolts (M10x35) for the outer bumper support bracket. Retain bolts for re-use later.
25. Remove the 10mm hex bolt for the middle bumper support bracket.
26. Repeat for the other side.

**TOOLS REQUIRED**

15mm socket  
10mm socket

**FASTENERS**

6x M10x35 hex bolt (retain)  
2x 10mm hex bolt





27. Support the bumper with a trolley or assistance from another person and pull outwards from the vehicle. Untuck the wheel arch liners from the bumper to do so.

28. Fully remove the bumper and set aside.

**TOOLS REQUIRED**

**FASTENERS**



29. Remove the 3x 15mm hex bolts (M10x35) securing the bumper bracket to the chassis. Retain bolts for re-use.

30. Repeat on other side.

**TOOLS REQUIRED**

15mm socket/spanner

**FASTENERS**

6x M10x35 hex bolt

Retain for re-assembly



31. Unclip and remove the plastic trim on the front of the tow hook.
32. Remove the 2x 18mm hex bolts (M12x40 and M12 long) securing the tow hook to the chassis. Retain bolts for re-use.
33. Repeat for the other tow hook.

**TOOLS REQUIRED**

Flat blade screwdriver  
or  
Trim tool  
  
18mm socket/spanner

**FASTENERS**

2x M12x40 hex bolt  
Retain for re-assembly  
  
2x M12 hex bolt (long)



34. Remove the 4x 13mm hex bolts securing the underpanel to the chassis. Retain bolts for re-use.

**TOOLS REQUIRED**

13mm socket

**FASTENERS**

4x 13mm hex bolt

Retain for re-assembly

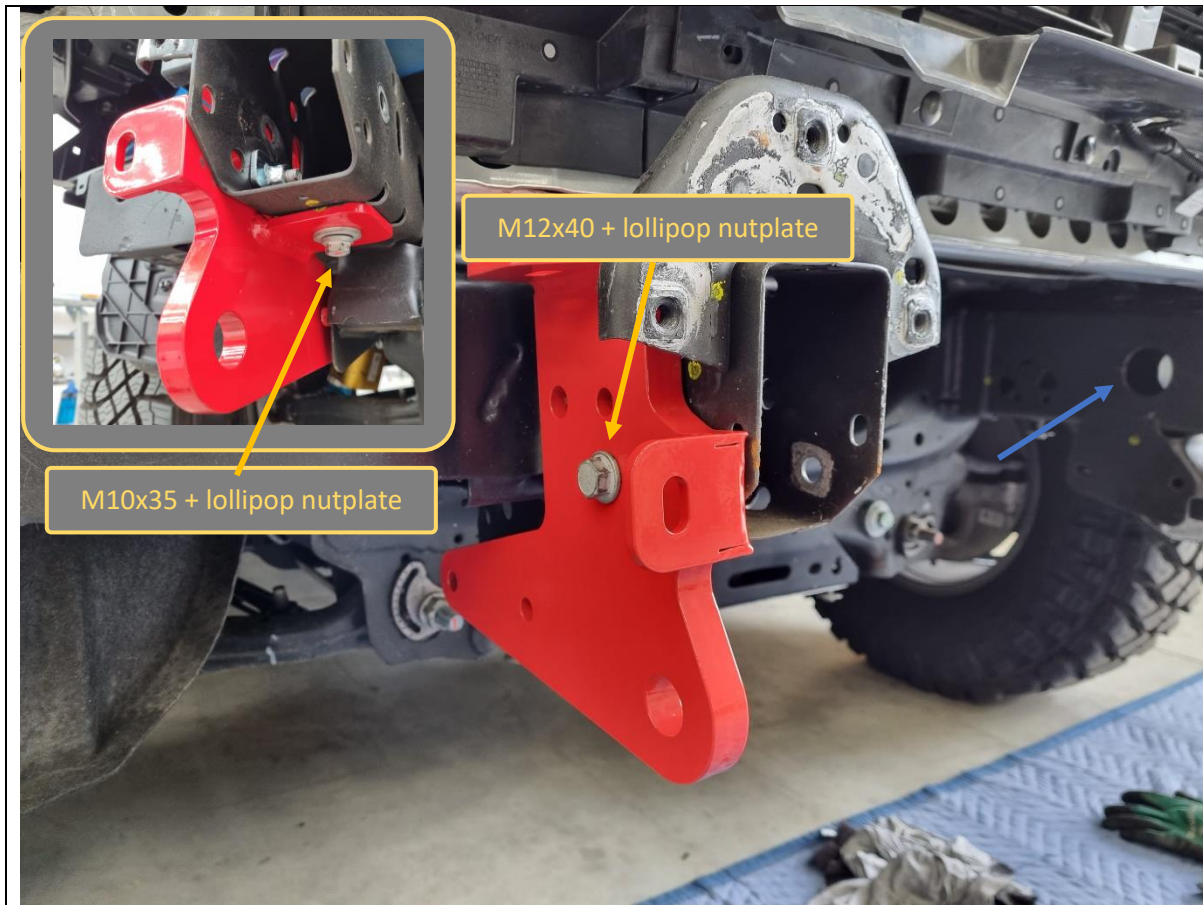

35. Fit the RH tow point to the vehicle using the retained factory M12x40 hex bolt (from Step 32) + M12 nutplate on the side and factory M10x35 hex bolt (from Step 24) + M10 nutplate on the bottom.

The lollipop nutplates can be insert through the open hole on the inside of the chassis (see blue arrow for reference).

**TOOLS REQUIRED**

15mm socket  
18mm socket

**FASTENERS**

1x factory M10x35 hex bolt  
1x M10 lollipop nutplate  
  
1x factory M12x40 hex bolt  
1x M12 lollipop nutplate

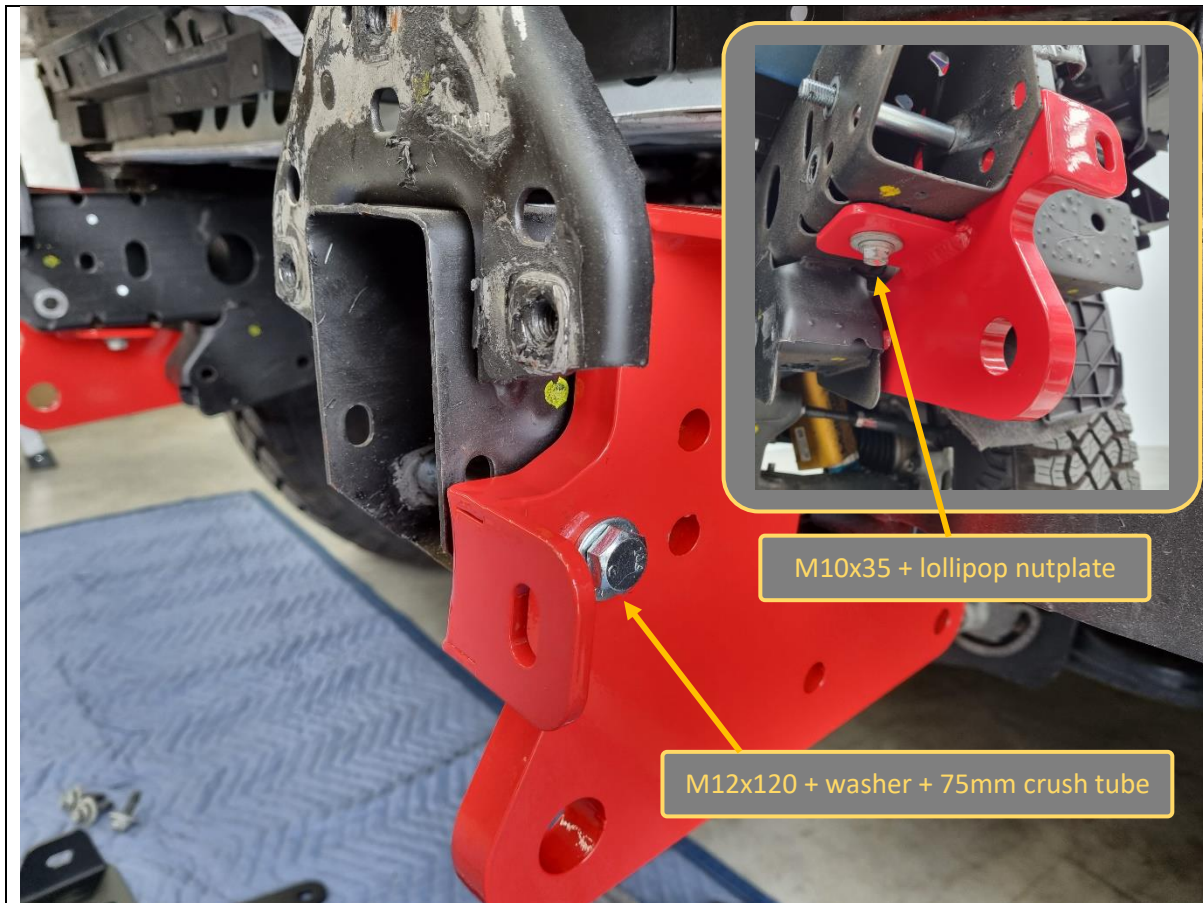

36. Fit the LH tow point to the vehicle using the retained factory M10x35 hex bolt (from Step 24) + M10 nutplate on the bottom.
37. Also loosely fit the tow point in place using 1x M12x120, flat washer and 75mm crush tube through the side. Do not secure with nut yet.

**TOOLS REQUIRED**

- 15mm socket
- 18/19mm socket

**FASTENERS**

- 1x factory M10x35 hex bolt
- 1x M10 lollipop nutplate
  
- 1x M12x120 hex bolt
- 1x M12 flat washer
- 1x 75mm crush tube

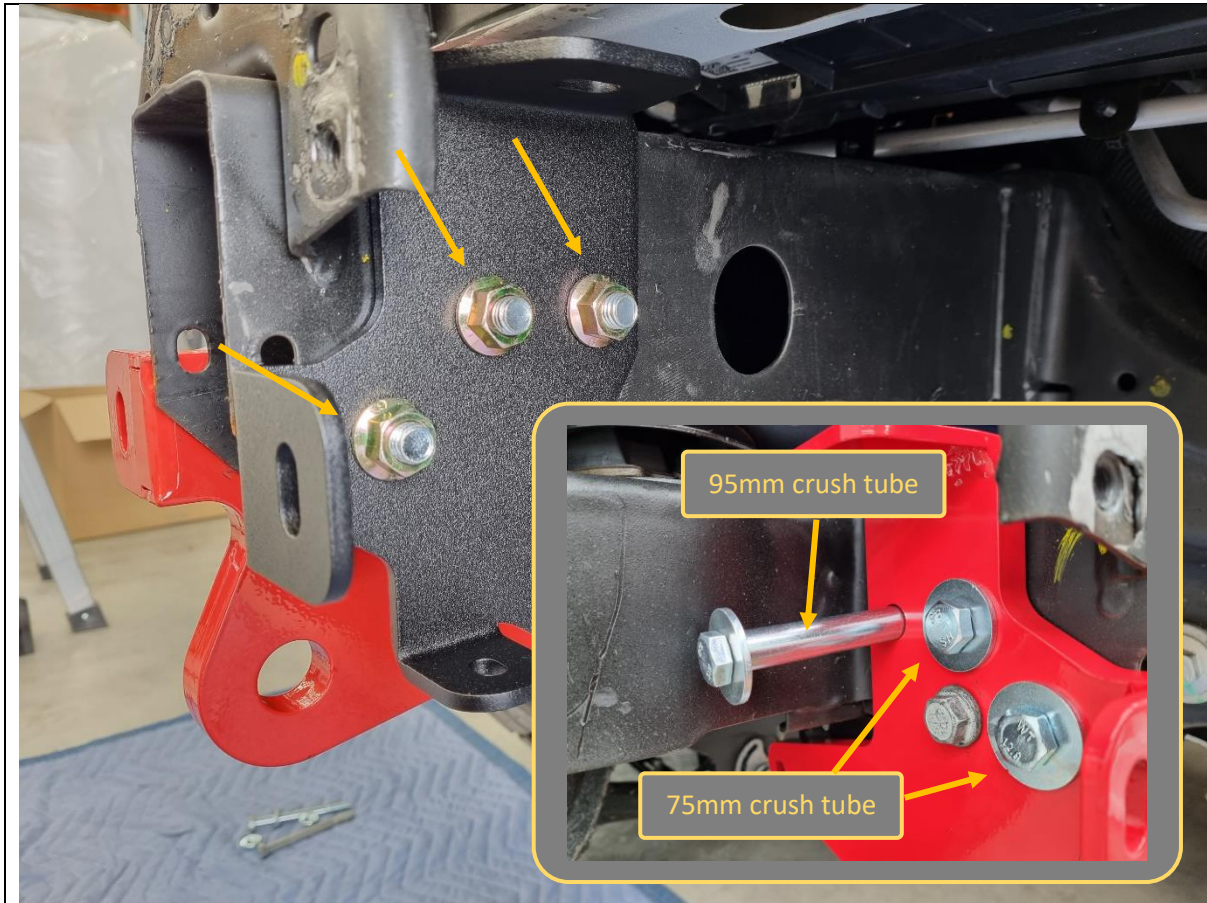

38. Fit the RH chassis mount brace bracket to the inside of the RH chassis rail and secure with 3x M12x120 hex bolt, 3x flat washer, 2x 75mm crush tube, 1x 95mm crush tube and 3x flange nut.

**TOOLS REQUIRED**

18/19mm socket

**FASTENERS**

3x M12x120 hex bolt  
3x M12 flat washer  
2x 75mm crush tube  
1x 95mm crush tube  
3x M12 flange nuts

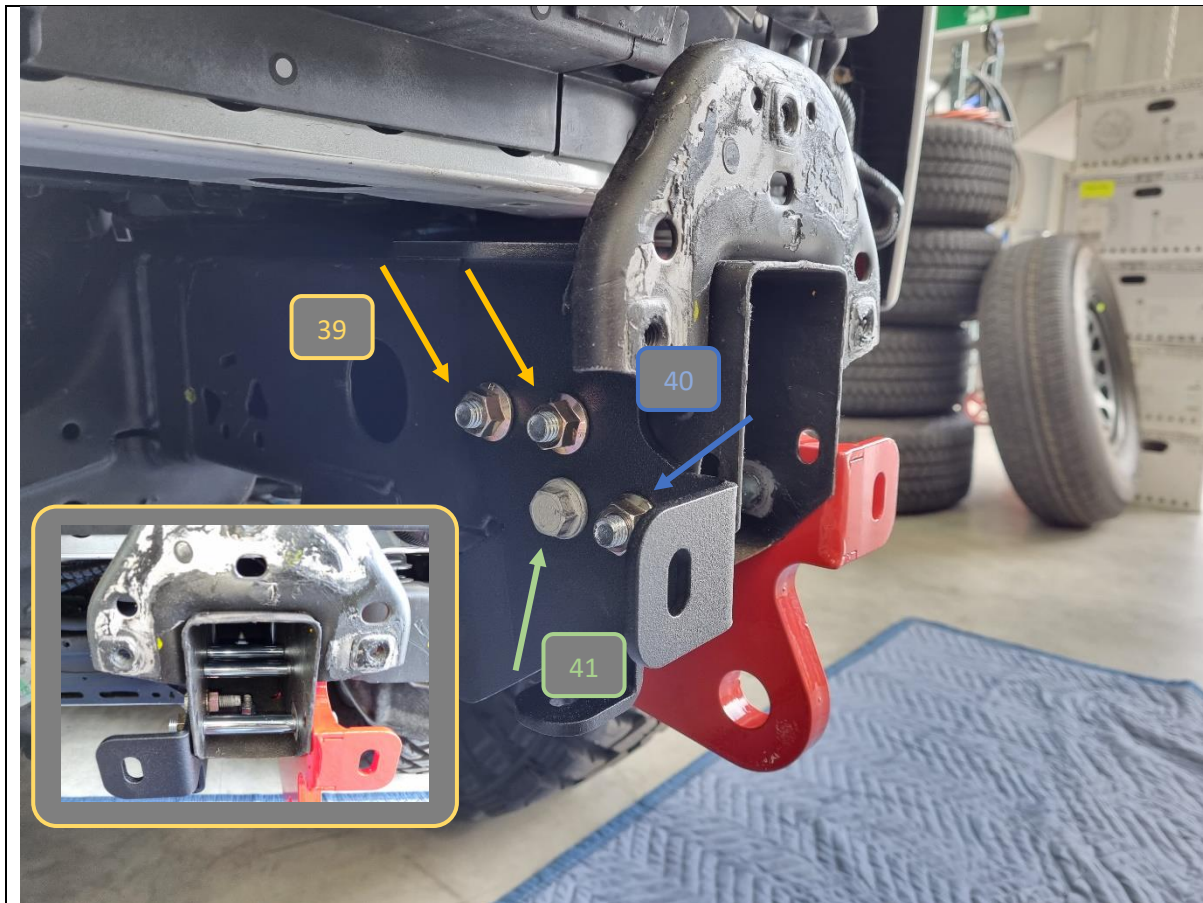

39. Fit the LH chassis mount brace bracket to the inside of the LH chassis rail and secure with 2x M12x120 hex bolt, 2x flat washer, 1x 75mm crush tube, 1x 95mm crush tube and 2x flange nut.

40. Secure the loose M12x120 from Step 37 with an M12 flange nut.

41. Fit the retained factory M12x40 hex bolt (from Step 24) + M12 nutplate on the side.

**TOOLS REQUIRED**

18/19mm socket

**FASTENERS**

2x M12x120 hex bolt  
2x M12 flat washer  
1x 75mm crush tube  
1x 95mm crush tube  
3x M12 flange nuts

1x factory M12x40 hex bolt  
1x M12 lollipop nutplate



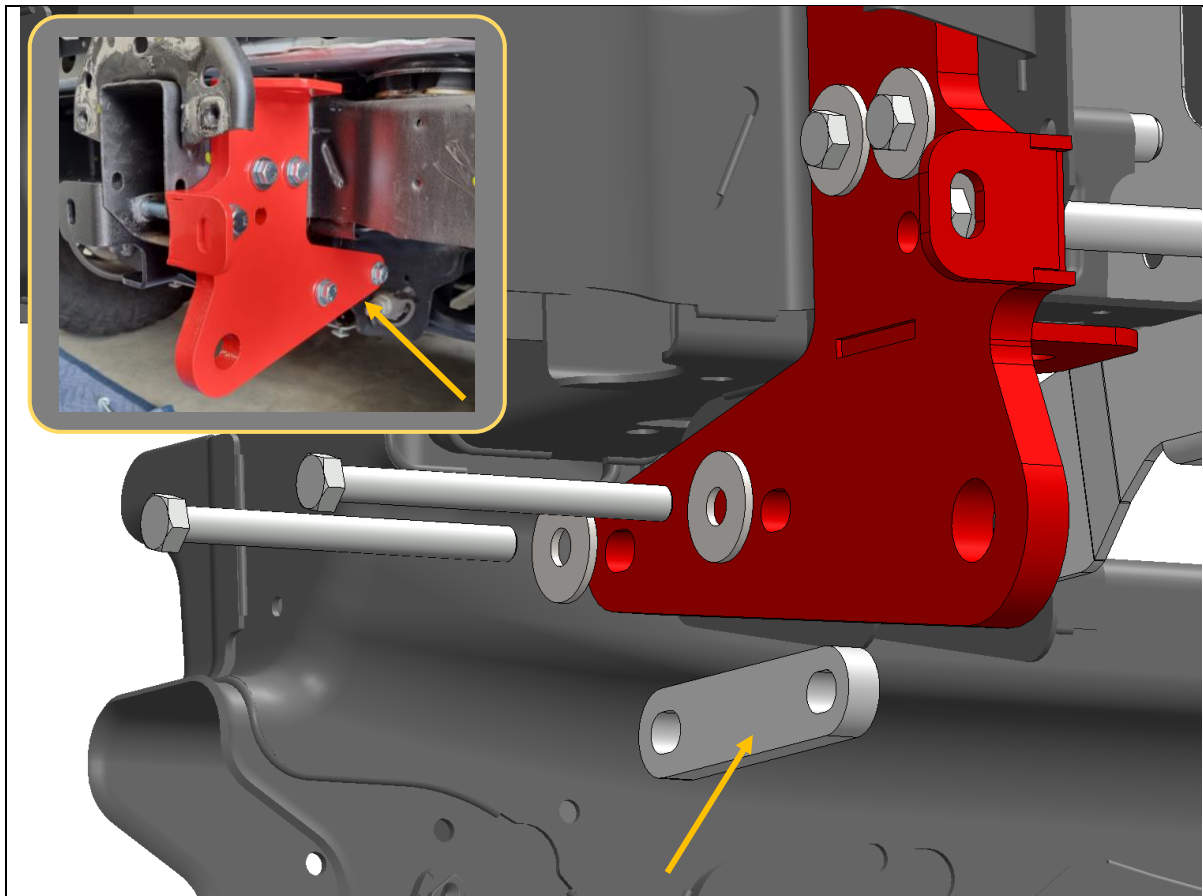

42. Insert the rear tow point spacer plate between the tow point and chassis at the rear, then loosely secure with 2x M12x130 hex bolts, flat washers and flange nuts.

Keep bolts finger tight at this stage.

43. Tighten all other fasteners in the tow point and chassis mount brace bracket, except for those 2x rear bolts.

44. Repeat for the LHS tow point.

**TOOLS REQUIRED**

15mm socket  
18/19mm socket

**FASTENERS**

2x M12x130 hex bolt  
2x M12 flat washer  
2x M12 flange nuts

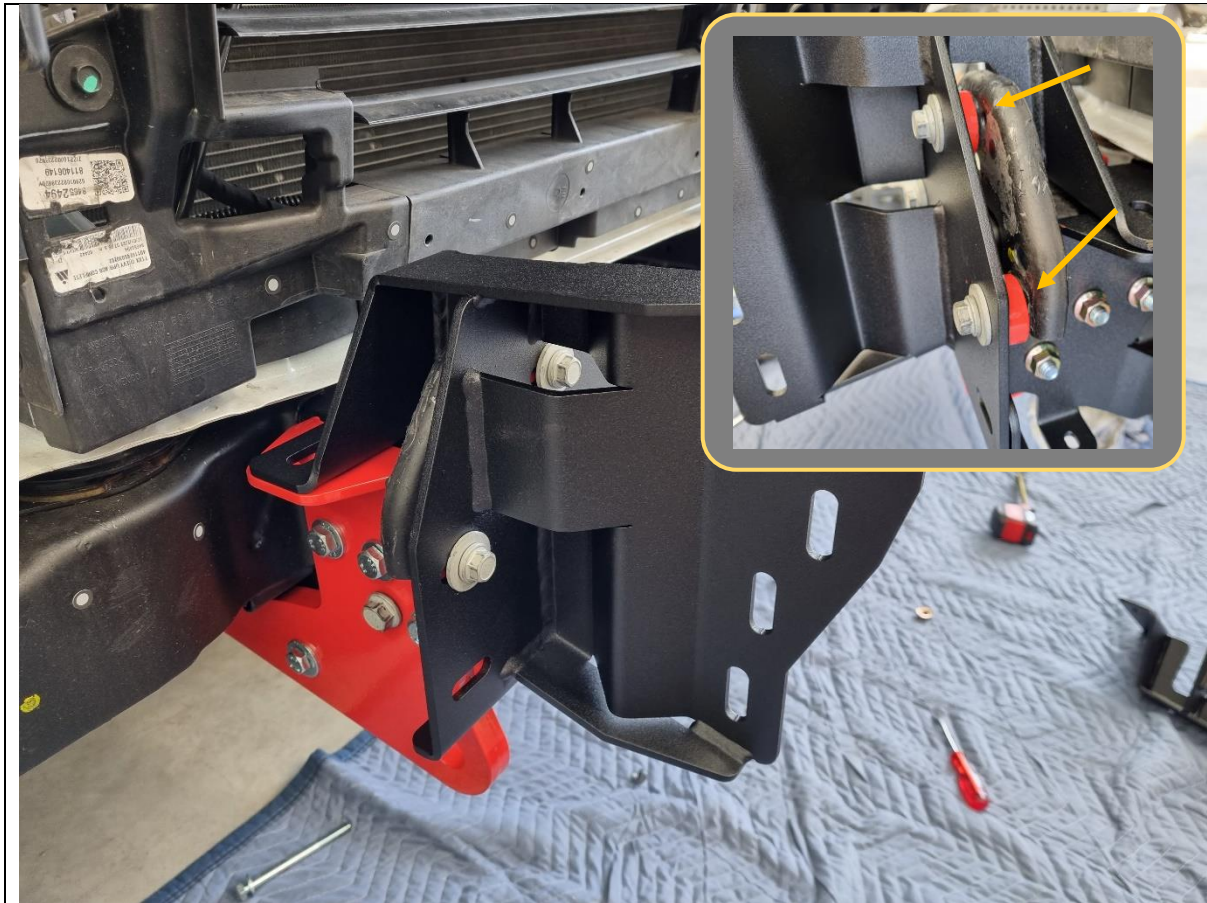

- 45. Slide the RH impact assembly from the side and onto the chassis.
- 46. Loosely secure to the chassis with 3x factory retained M10x35 hex bolts (from Step 29) and round tow point spacer blocks wedged inbetween (see inset).
- 47. Repeat for the LH impact assembly.

**TOOLS REQUIRED**

15mm socket

**FASTENERS**

6x factory M10x35 hex bolt

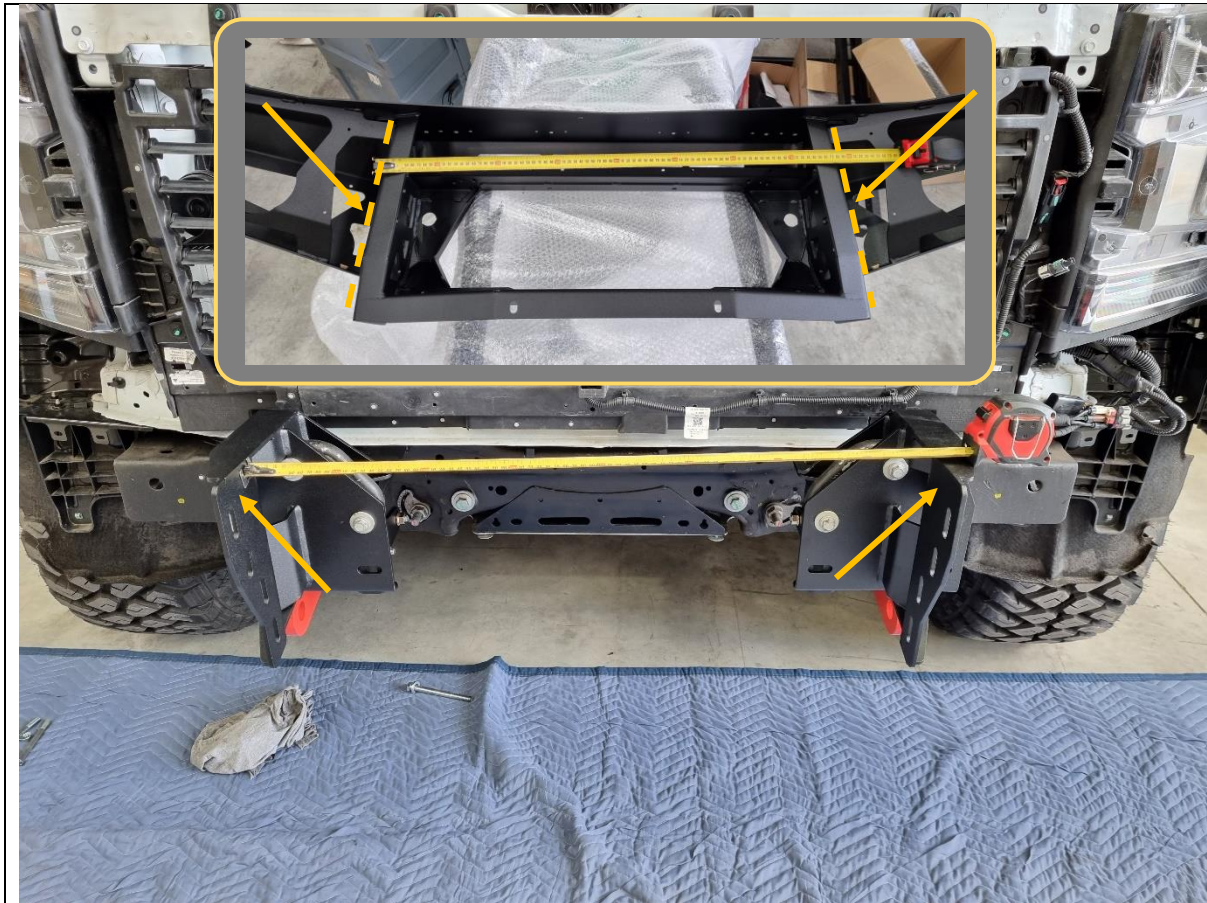

48. Measure the distance between the outside faces of uprights on bar using tape measure. Write distance below for reference if required.

Bar Upright Width = \_\_\_\_\_mm

49. Adjust mounts by sliding left/right on the slots, such that distance between inner faces of mounts are approximately 2mm more than bar. Ensure the mount faces are vertically upright and symmetric left/right on the chassis.

50. Secure and tighten mounts.

**TOOLS REQUIRED**

Tape measure

15mm socket

**FASTENERS**

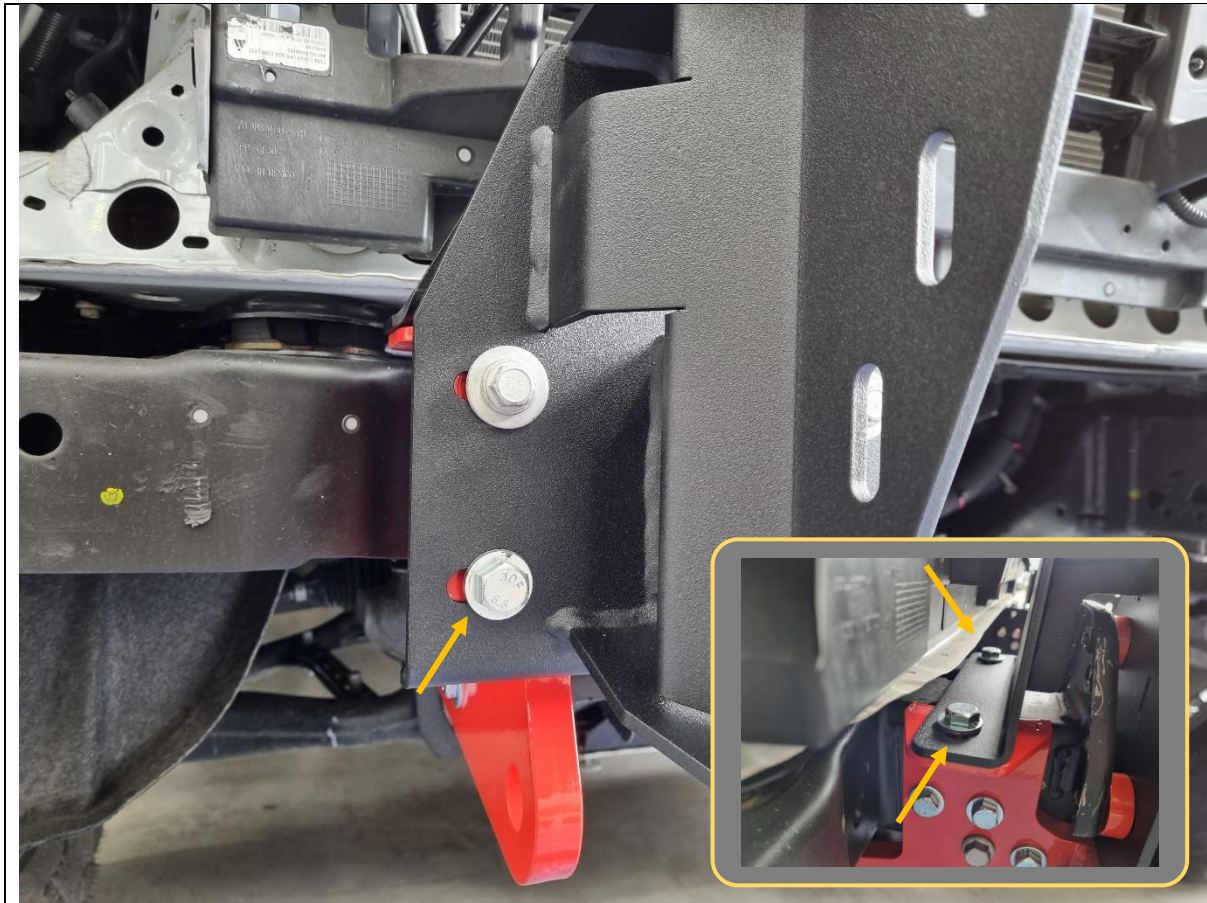

51. Fit remaining 4x M12x30 hex bolts, flat washers and flange nuts for the RH impact assembly.

The 2x bolts on the lower face can be tightened with a socket.

The 2x bolts on the top flange can be tightened with a spanner.

52. Repeat for the LH impact assembly.

**TOOLS REQUIRED**

18/19mm spanner  
18/19mm socket

**FASTENERS**

8x M12x30 hex bolt  
8x M12 flat washer  
8x M12 flange nut

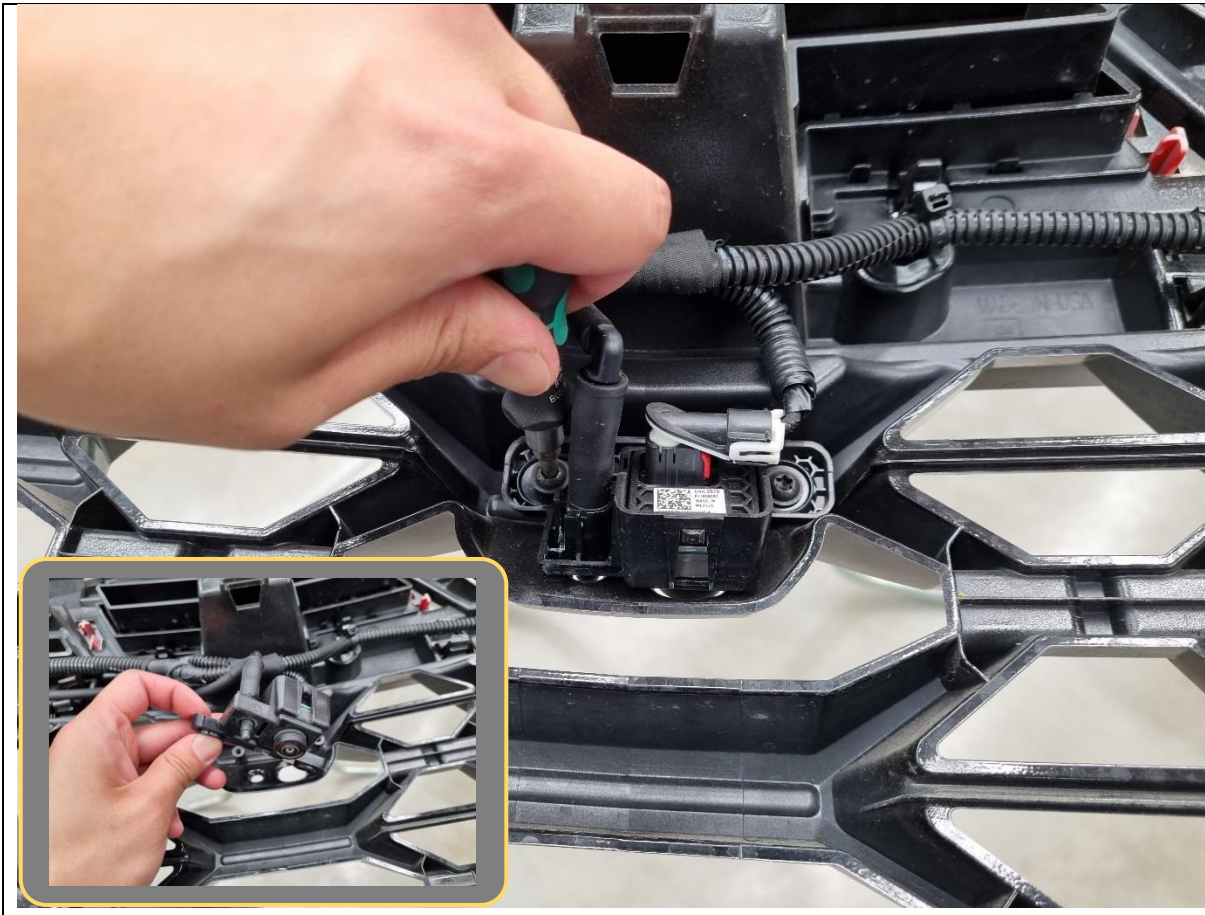

53. The front camera can be optionally relocated from the grille into the bar for a clearer unobstructed view. This is especially recommended if running optional driving lights or top tubes.

Unscrew the T20 Torx screws and separate the camera/washer and housing from the grille.

**TOOLS REQUIRED**

T20 Torx Driver

Trim Tool

**FASTENERS**



54. Unclip the camera harness and rubber washer hose from the grille.

**TOOLS REQUIRED**

**FASTENERS**



55. Disconnect the camera harness and washer hose on the camera body side and reconnect the other end back to the vehicle. Set aside the camera for later.

56. Route the harness over the top of the LH impact assembly towards the centreline of the vehicle.

**TOOLS REQUIRED**

**FASTENERS**

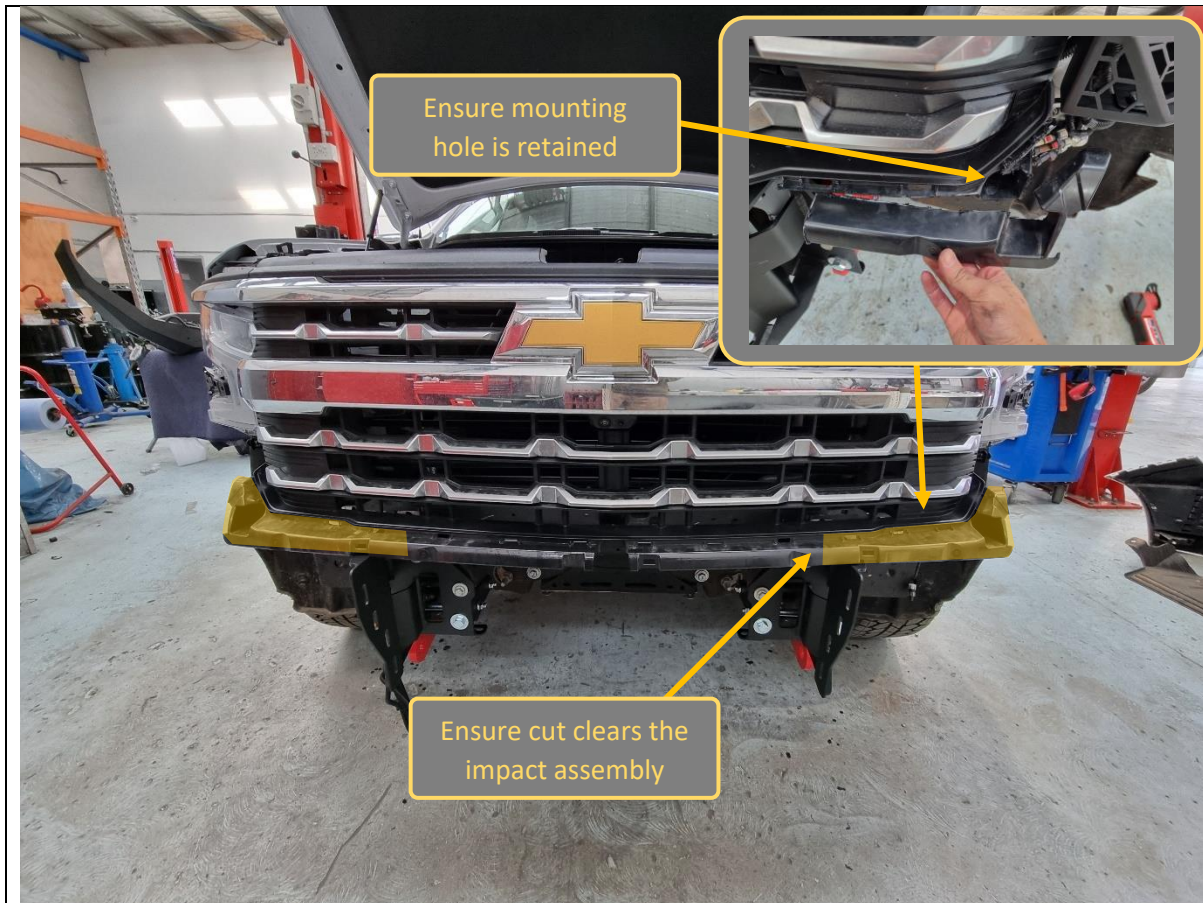

<p>57. Rest the grille back on the vehicle.</p> <p>58. Use masking tape and/or a marker pen and mark out the highlighted section on the bottom of the grille. Mark the inner edge on each side such that it clears the impact assemblies.</p> <p>59. Remove the grille and perform the cut with an oscillating multi-tool or similar cutting tool. Ensure the outer mounting holes on the grille are retained and are not chopped off.</p>	<p><b>TOOLS REQUIRED</b></p> <p>Masking tape Marker pen</p> <p>Oscillating multi-tool or similar cutting tool</p>
	<p><b>FASTENERS</b></p>



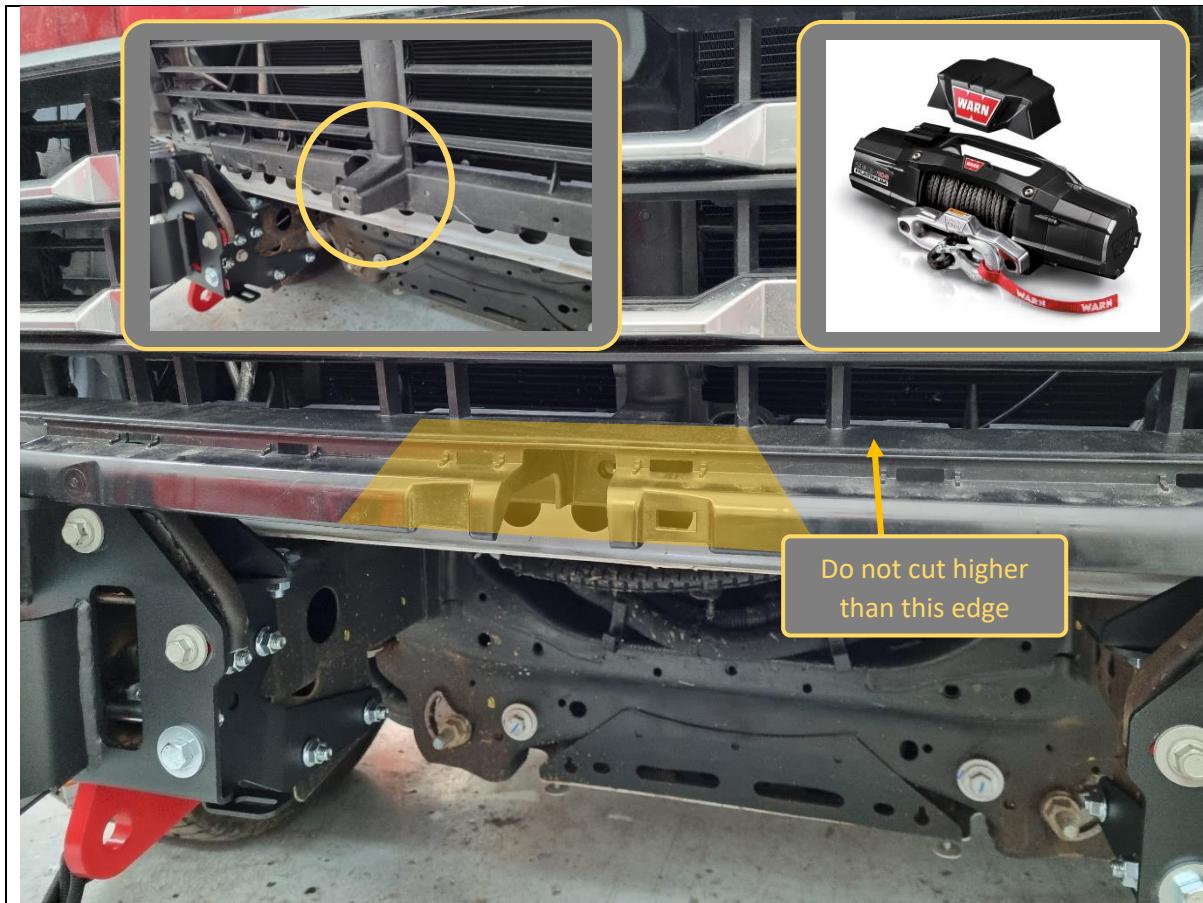

60. If fitting a WARN Zeon or a winch of similar size with top mounted control box (**taller than 200mm**), a small portion of the grille may need to cut to provide adequate clearance to the control box. It is best to do this before the bar is fully installed onto the vehicle.

61. If the control box sits in the middle, the mounting post also needs to be cut back by approximately 30mm (see top left inset photo).

**TOOLS REQUIRED**

Oscillating multi-tool  
or similar cutting tool

**FASTENERS**



- 62. Re-fit the grille to the vehicle and reconnect the camera harness and washer hose if not relocating.
- 63. Secure with same original fasteners from disassembly.
- 64. Re-fit the radiator grille cover and bonnet release handle in reverse order using original clips and fasteners.

**TOOLS REQUIRED**

**FASTENERS**



65. Remove the bumper clip underneath the headlight by loosening 3x T15 Torx screws. Do not discard the fasteners.

**TOOLS REQUIRED**

T15 Torx Driver

**FASTENERS**

6x factory T15 Torx screw

Retain for re-assembly



66. Clean the top face of the supplied facelift infill bracket with isopropyl alcohol or similar cleaning solvent and let it dry.

67. Apply the supplied 3M Primer 94 adhesion promotor from the tape kit onto the same top face of the infill.

**Important:** allow at least 5 minutes for the primer to chemically bond to the surfaces.

68. Apply 4x 100mm strips of supplied VHB tape in the arrangement shown.

**TOOLS REQUIRED**

Isopropyl alcohol  
Rag

**FASTENERS**

VHB Tape pads  
3M Primer 94

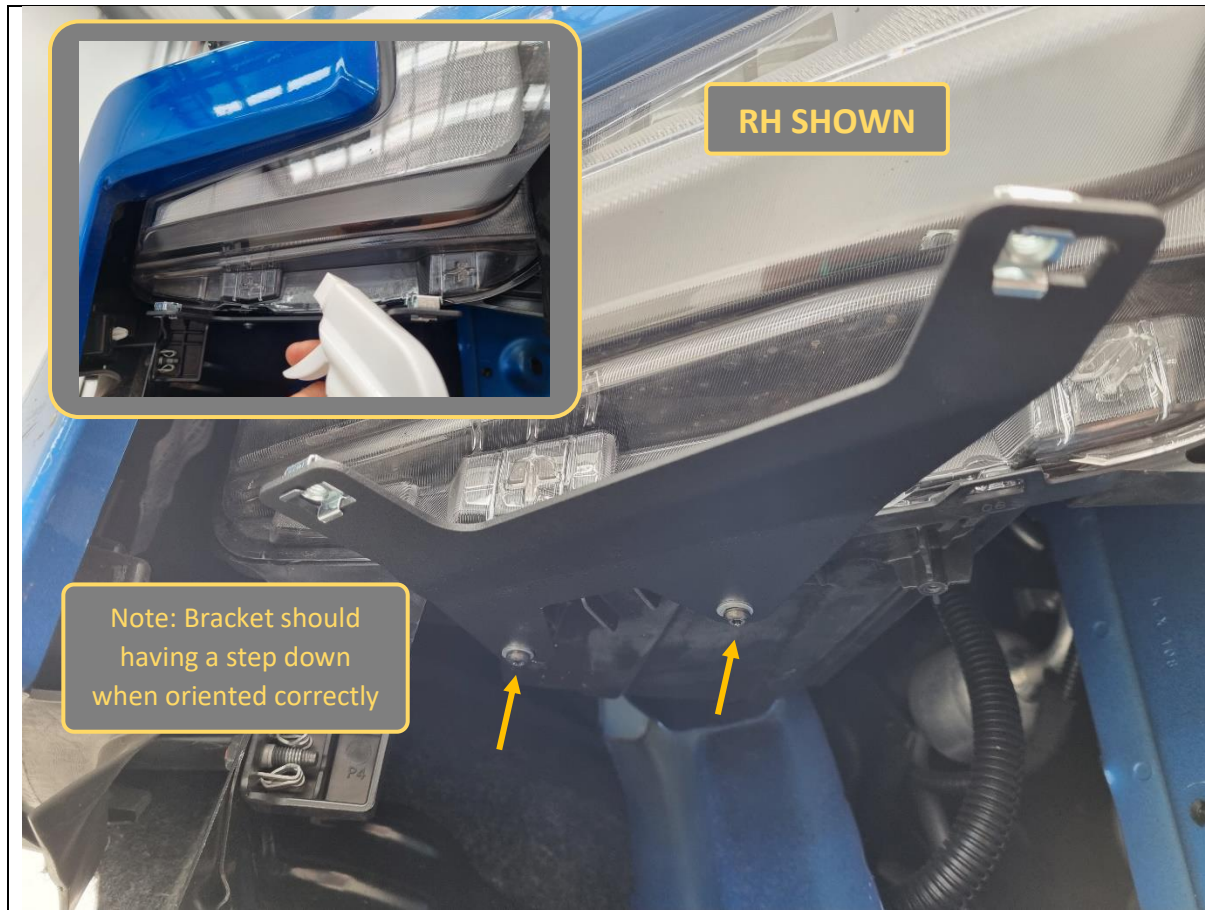

- 69. Clean the underside face of the headlight with isopropyl alcohol or similar cleaning solvent and let it dry.
- 70. Apply 3M Primer 94 to the headlight surface and allow at least 5 minutes for it to cure.
- 71. Fit 2x M6 cage nuts into the headlight infill support bracket. Use a flat head screwdriver to assist.
- 72. Fit the headlight infill support bracket to the underside of the headlight using 2x factory retained T15 Torx screws and 2x M5 flat washers.
- 73. Repeat for other side.

**TOOLS REQUIRED**

Isopropyl alcohol  
Rag

Flat head screwdriver

T15 Torx driver

**FASTENERS**

3M Primer 94

4x factory T15 Torx screw  
4x M5 flat washer



- 74. Remove backing film of VHB tape and present infill up against the bottom face of the headlight.
- 75. Align the infill so it is central and in line with the front face of the headlight.
- 76. Apply even pressure for 20-30 seconds to ensure best adhesion of the tape to the headlight.
- 77. Secure the infill to the support bracket with 2x M6x16 black button head bolts and 2x black flat washers.
- 78. Repeat for other side.

**TOOLS REQUIRED**

4mm hex/Allen key

**FASTENERS**

4x M6x16 black button head  
4x M6 black washer  
4x M6 cage nut



79. Using a 10mm socket, remove all the bolts securing the wheel guard bracket to the vehicle and headlight.

Retain these fasteners for re-use.

**TOOLS REQUIRED**

10mm socket

**FASTENERS**

10mm hex bolts

Retain for re-assembly



<p>80. Clean the outer face of the bumper winglet support with isopropyl alcohol or similar cleaning solvent and let it dry.</p> <p>81. Apply the supplied 3M Primer 94 adhesion promotor from the tape kit onto the same outer face. Allow time to cure.</p> <p>82. Apply 2x 100mm strips of supplied VHB tape in the arrangement shown.</p>	<p><b>TOOLS REQUIRED</b></p>
<p>83. Fit the bumper winglet support to the supplied headlight bracket and loosely secure with 2x M6x12 hex bolts, flat washers and flange nuts. Bumper winglet support goes on the back of the headlight bracket, as shown.</p> <p>84. Repeat for other side.</p>	<p><b>FASTENERS</b></p> <p>4x M6x12 hex bolt 4x M6 flat washer 4x M6 flange nut</p>



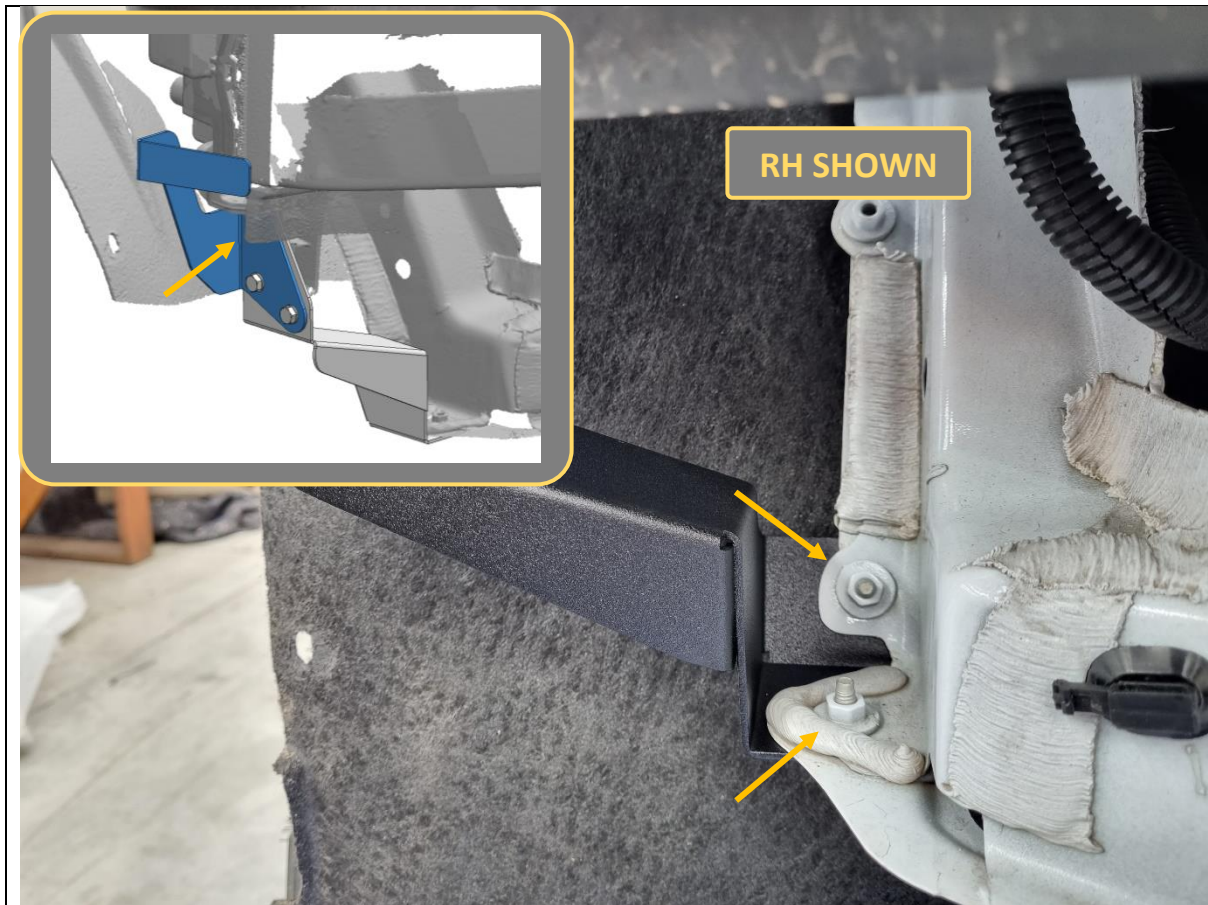

- 85. Fit the headlight bracket and bumper winglet support to the vehicle.
- 86. Secure the brackets to the headlight with 1x 10mm hex bolt (from Step 79)
- 87. Fit the bottom of the headlight bracket to the body with 2x 10mm hex bolts (also from Step 79).
- 88. Repeat for other side of vehicle.

**TOOLS REQUIRED**

10mm socket

**FASTENERS**

6x factory 10mm hex bolts

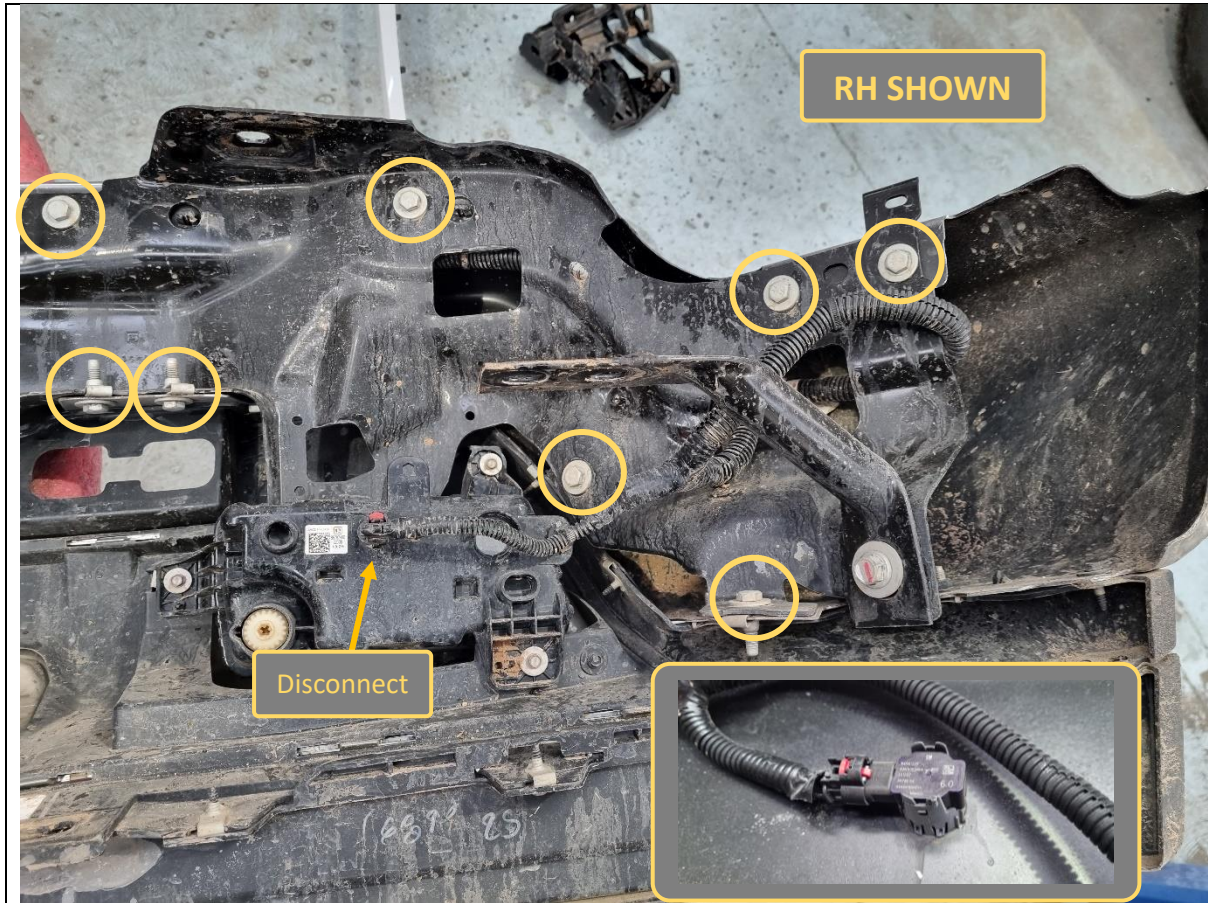

<p>89. Prepare the bumper for stripping parts.</p> <p>90. Remove the number plate and set aside.</p> <p>91. Undo the 13mm hex bolts securing the inner bumper reinforcement (per side) to the bumper.</p> <p>92. Cut any cable ties and pry off any loom clips to free the reinforcement piece and discard.</p>	<p><b>TOOLS REQUIRED</b></p> <p>13mm socket</p> <p>Side cutters</p> <p>Trim tool</p>
<p>93. Unplug the fog light connector on each side..</p> <p>94. Unclip the 4x parking sensors from their plastic holders. The holders will not be re-used.</p> <p>Note down the orientation of the parking sensors before fully removing.</p>	<p><b>FASTENERS</b></p>



- 95. Prepare the bar for fitment. Start by routing wiring harness through the bar such that all plugs are in the correct location. Secure loom with cable ties to the bar.
- 96. If the option has been selected, fit the Offroad Animal Halo fog lights to the supplied fog light brackets using 4x M4x12 pan head screws, flat washers and flange nuts (each).

**TOOLS REQUIRED**

- Phillips head screwdriver
- Cable ties

**FASTENERS**

- 8x M4x12 pan head
- 8x M4 flat washer
- 8x M4 flange nut

<div data-bbox="469 309 711 383" data-label="Text"> <p><b>RH SHOWN</b></p> </div> <div data-bbox="903 215 1396 528" data-label="Image"> </div> <div data-bbox="304 472 1275 1066" data-label="Image"> </div>	
<p>97. Fit the fog light and bracket to the mesh panel, using the supplied 2x M8x12 hex bolts, flat washers and flange nuts.</p> <p>Match the orientation as shown.</p> <p>98. Repeat for other fog light.</p>	<p><b>TOOLS REQUIRED</b></p> <p>13mm socket</p>
	<p><b>FASTENERS</b></p> <p>4x M8x12 hex bolt 4x M8 flat washer 4x M8 flange nut</p>



- 99. Fit the fog light + mesh panel to the bulbar using 4x M16x16 black button head bolts, black flat washers and flange nuts.
- 100. Secure and tighten using 4mm hex/Allen key and repeat for other side.
- 101. Re-wire the fog light and connect to the bumper loom.

**TOOLS REQUIRED**

4mm hex/Allen key

**FASTENERS**

8x M6x16 black button head  
8x M6 black washer  
8x M6 flange nut

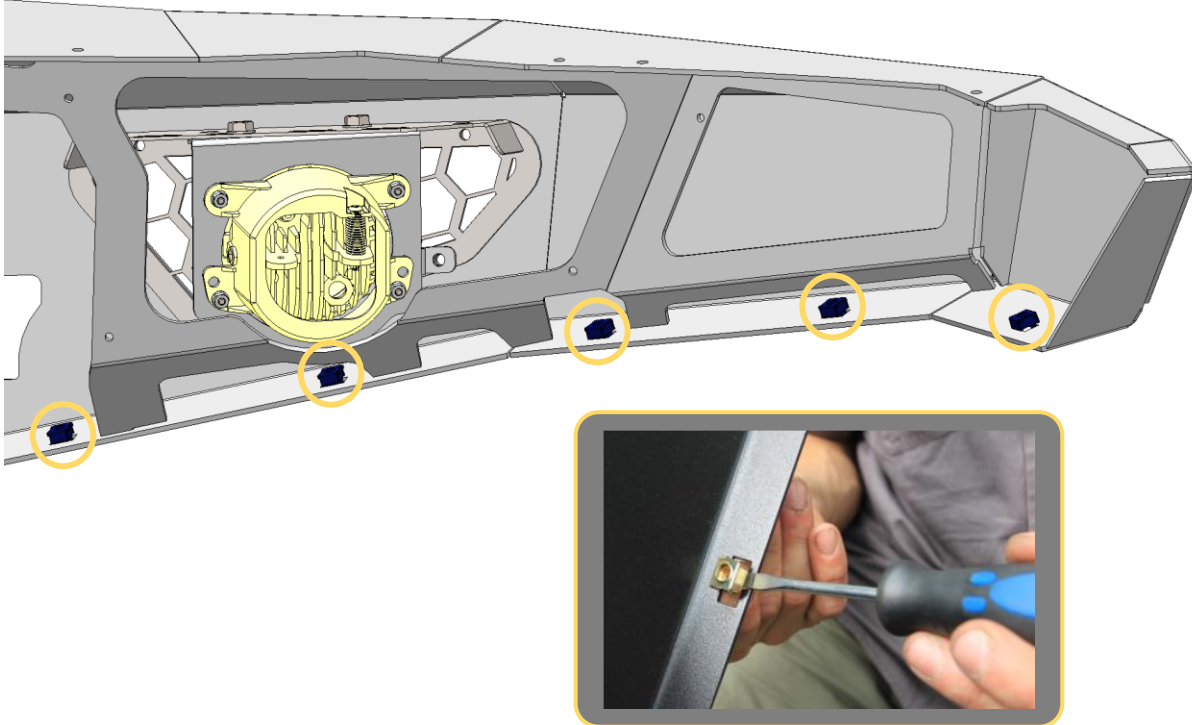
<div data-bbox="949 280 1193 347" style="border: 1px solid black; padding: 2px; display: inline-block; background-color: #f0f0f0;"> <b style="color: #000080;">RH SHOWN</b> </div>	
	
<p>102. Fit 5x M6 cage nuts into the rectangular slots on the bottom of the bar wing.</p> <p>To aid fitting, use a small flat blade screwdriver to push the edge of the cage nut to engage with the slot.</p> <p>103. Repeat for other side of the bar.</p>	<p><b>TOOLS REQUIRED</b></p> <p>Flat blade screwdriver</p>
	<p><b>FASTENERS</b></p> <p>10x M6 cage nut</p>



<p>104. If fitting an integrated light bar, do so now.</p> <p>This bar is designed to fit the Offroad Animal 22-inch light bar. If fitting this light bar, assemble the light bar with legs facing outwards, and line it up with the slots in the centre gusset. Secure with M6 fasteners supplied with the light.</p>	<p><b>TOOLS REQUIRED</b></p> <p>4mm hex/Allen key 10mm spanner</p> <p>Supplied with light bar</p>
<p>This bar can accommodate most other “20-22inch” size light bars.</p> <p>105. If fitting driving lights or top hoop to this bar, this is also the most convenient time to do so. It is still possible later but is more difficult.</p> <p>106. Fit the pan brace to the back of the bar using 5x M6x16 black button head bolts, flat washers and flange nuts.</p>	<p><b>FASTENERS</b></p> <p>5x M6x16 black button head 5x M6 black flat washer 5x M6 flange nut</p> <p>Supplied with light bar</p>

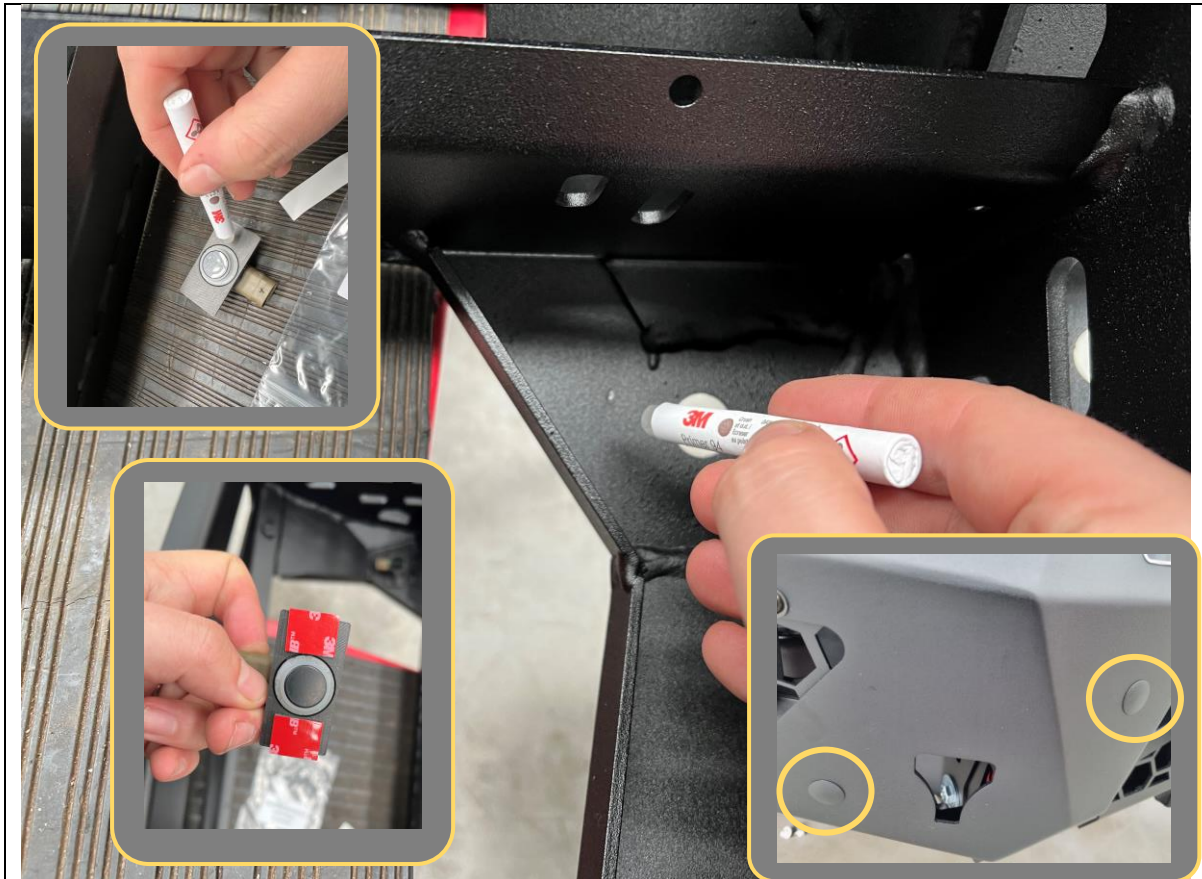

107. If not fitting parking sensors, fit the 4x supplied round plastic blanking plugs into the holes of the bar where parking sensors would be located.
108. Otherwise, clean area surrounding the parking sensor holes in the bar with isopropyl alcohol or similar cleaning solvent and let it dry.
109. Lightly scuff the bonding surfaces of the 4x supplied plastic sensor housings with sandpaper. Then clean with isopropyl alcohol or similar.
110. Apply the 3M Primer 94 adhesion promotor from the tape kit to the parking sensor locations, on both the bar and the sensor housings.  
**Allow at least 5 minutes for it to cure before applying tape.**
111. Apply supplied VHB tape pads to all sensor housings as shown in the inset photo.
112. Dry fit sensors to bar to check loom position is correct.
113. Remove backing and adhere sensors in position in bar. Apply pressure for 20-30sec after positioning for best adhesion.
114. Add a pea-sized blob of automotive adhesive sealant over the sensor holder and inside face of bar to hold to ensure the tape holds position.
115. Connect all parking sensor loom connectors.

**TOOLS REQUIRED**

Isopropyl alcohol  
Rag  
Sandpaper  
Automotive adhesive sealant (eg. Sikaflex)

**FASTENERS**

4x plastic blanking plugs  
or  
VHB Tape pads  
Primer 94



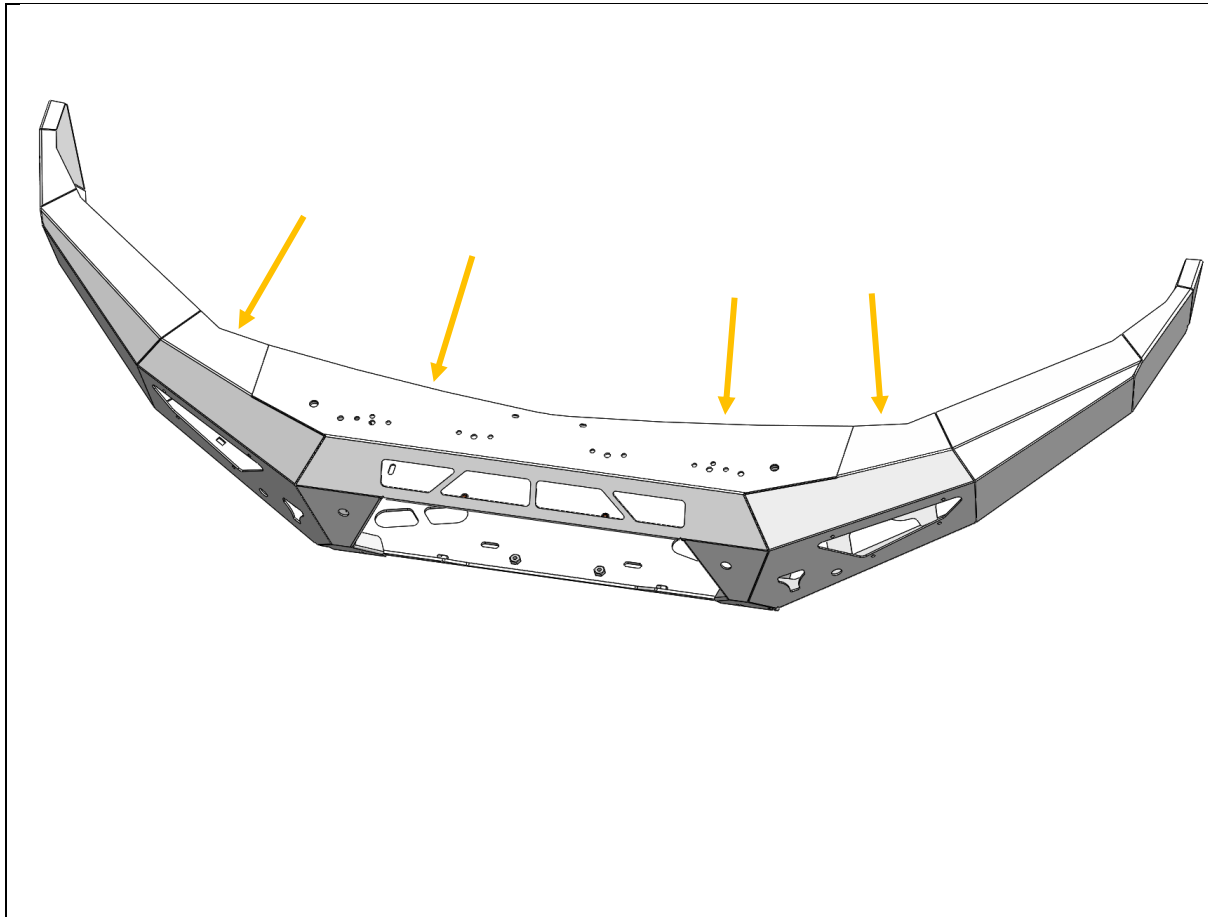

116. **Optional.** Fit the supplied pinch weld lengths across the middle of the bar. This can also be done once the bar is on the vehicle.

**TOOLS REQUIRED**

**FASTENERS**

Bulb pinch weld



- 117. With assistance, either from another person, or a lifting trolley, lift the bar onto the mounts on the vehicle.
- 118. Reconnect the bumper wiring harness to the vehicle.
- 119. Secure with 8x M12x30 Bolts, heavy duty washers and M12 Nyloc + flange nuts. Leave finger tight at this stage.

Note: Use a washer on both bolt and nut side for the Nyloc nut. 1x washer on the bolt side is all that is required with flange nuts.

**TOOLS REQUIRED**

Lifting trolley

**FASTENERS**

8x M12x30 hex bolt  
10x M12 heavy duty washer  
2x M12 Nyloc nut  
6x M12 flange nut

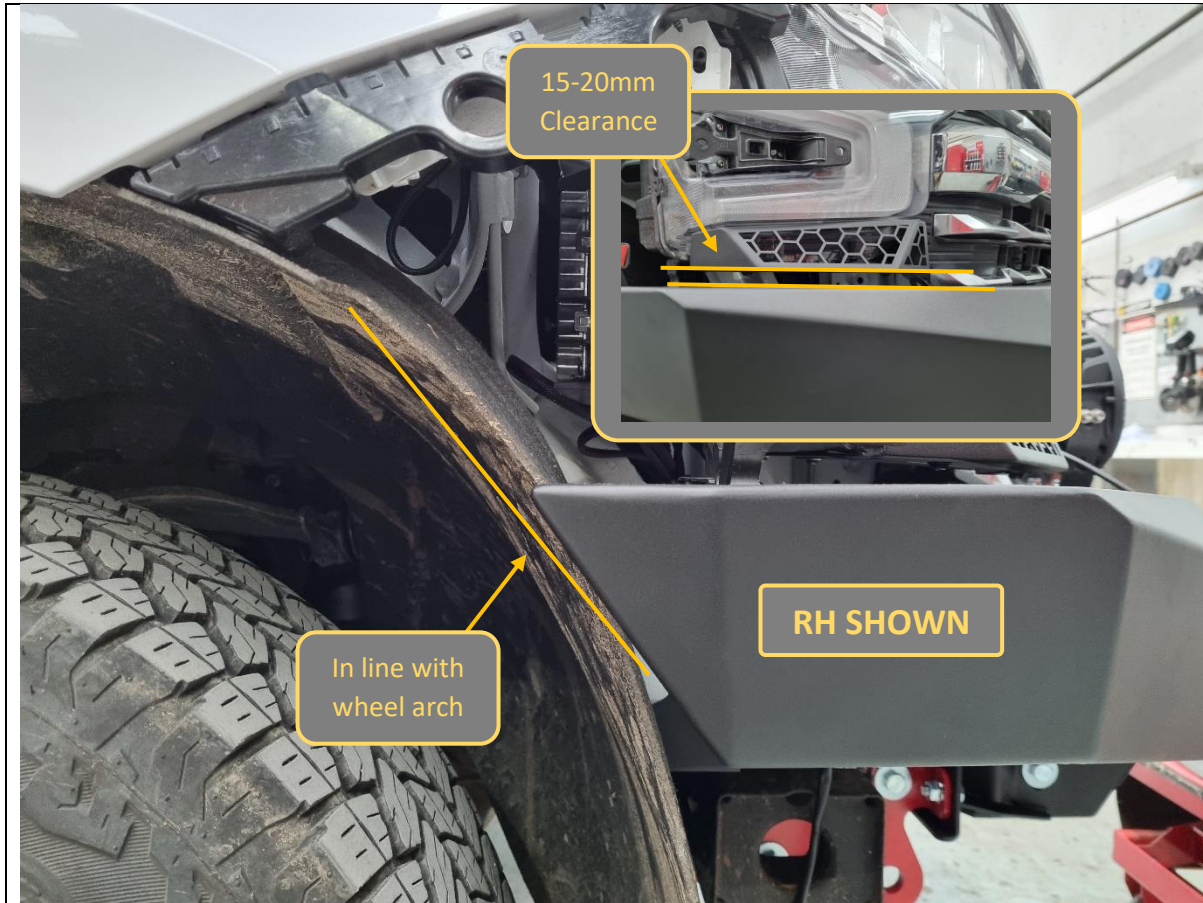

<p>120. With assistance, from another person, align the bar with the edges of the vehicle. The bar should sit symmetric left/right on the vehicle.</p> <p>In front view, the top face of the bar should sit parallel with the ground, and have about 15-20mm vertical clearance to the bottom of the headlight infill.</p> <p>In side view, the end of the bar wing should be in line with the wheel arch liner.</p>	<p><b>TOOLS REQUIRED</b></p> <p>Lifting trolley</p> <p>18/19mm socket</p>
<p>121. Once happy with alignment, tighten all 8x M12 bolts.</p>	<p><b>FASTENERS</b></p>



- 122. The plastic bumper will now need to be trimmed into 2x halves to fit with the bar.
- 123. On the inside of the bumper, cut out the internal vents on each side, as shown.

**TOOLS REQUIRED**

Oscillating multi-tool  
or similar cutting tool

**FASTENERS**



- 124. Begin with a conservative cut, approximately 15mm below the previously marked cut line.  
  
We recommend using a jigsaw as it tends to produce cleaner cuts without melting away the plastic.  
  
It is easier to cut the plastic bumper into separate sections first, so that it is easier to hold while cutting.
- 125. Test fit the trimmed panel by loosely holding it in position on the vehicle.
- 126. Make further trims and adjustments until the bottom edge of the bumper winglet is in line with the bottom of the headlight/infill and has 15-20mm vertical clearance to the bar.

**TOOLS REQUIRED**

Jigsaw  
or similar cutting tool

Marker pen  
Ruler

**FASTENERS**



- 127. Once final cut is complete, tidy up the cut edge with a utility knife, if required.
- 128. Clean the inner face of the trimmed bumper winglet, where it will contact the support bracket and tape on the car.

**TOOLS REQUIRED**

- Isopropyl alcohol
- Rag
- Utility knife (optional)

**FASTENERS**



- 129. Remove the backing film of the VHB tape on the winglet support bracket (installed in Step 82).
- 130. Clip the trimmed bumper winglet back onto the vehicle. Apply pressure for 20-30sec over where the tape is, after positioning, for best adhesion.
- 131. Do this for both bumper winglets.

**TOOLS REQUIRED**

**FASTENERS**



<p>132. If fitting a winch, do so now.</p> <p>This bar is designed to fit most low mount winches, in foot down configuration. WARN ZEON 12 is the largest winch confirmed to fit (with grille cut, see Step 60-61 for explanation)</p>	<p><b>TOOLS REQUIRED</b></p> <p>Refer to instructions supplied by winch</p>
<p>133. The control box can be mounted on top of the winch, or to the side as shown. Winches usually come with a bracket to allow this. Refer to winch manufacturer.</p> <p>In some rare cases, the winch control box may need to be relocated elsewhere using custom bracketry.</p> <p>134. Ensure clutch handle will be accessible through opening in front mesh panel. Refer to winch instructions regarding changing clutch handle location.</p>	<p><b>FASTENERS</b></p> <p>Supplied with winch</p>





- 135. Loosen the M12 flange nut on the rearmost chassis mount hole installed in Step 42.
- 136. Install the tension strap connecting the winch cradle to the rearmost chassis mount hole, using 1x M10x25 hex bolt, flat washer and flange nut. Re-secure the rear with the M12 flange nut.
- 137. Repeat on other side for other tension strap.

**TOOLS REQUIRED**

- 16mm socket
- 18/19mm socket

**FASTENERS**

- 2x M10x25 hex bolt
- 2x M10 flat washer
- 2x M10 flange nut



<p>138. If required, fit the winch fairlead to the mesh fairlead mount using M10 or 3/8" fasteners supplied with the winch. This bar is only compatible with hawse type fairleads.</p> <p>139. Fit number plate flip mount to mesh panel using 2x M6x20 hex bolts, flat washers and flange nuts supplied in the number plate flip kit.</p>	<p><b>TOOLS REQUIRED</b></p> <p>10mm socket 13mm socket/spanner 4mm hex/Allen key Phillips head screwdriver</p>
<p>140. Attach number plate to mount using supplied pan head screws in the number plate flip kit.</p>	<p><b>FASTENERS</b></p> <p>2x M6x20 hex bolt 2x M6 flat washer 2x M6 flange nut</p>



- 141. If relocating the front camera, secure the entire camera and mounting bracket to the supplied facelift camera housing using 2x M5x15 black button bolts, black flat washers and flange nuts.
- 142. Attach the camera and housing to the mesh fairlead with 2x M5x15 black button head bolts and black flat washers.

**TOOLS REQUIRED**

3mm hex/Allen key

**FASTENERS**

4x M5x15 black button head  
4x M5 black flat washer  
2x M5 flange nut

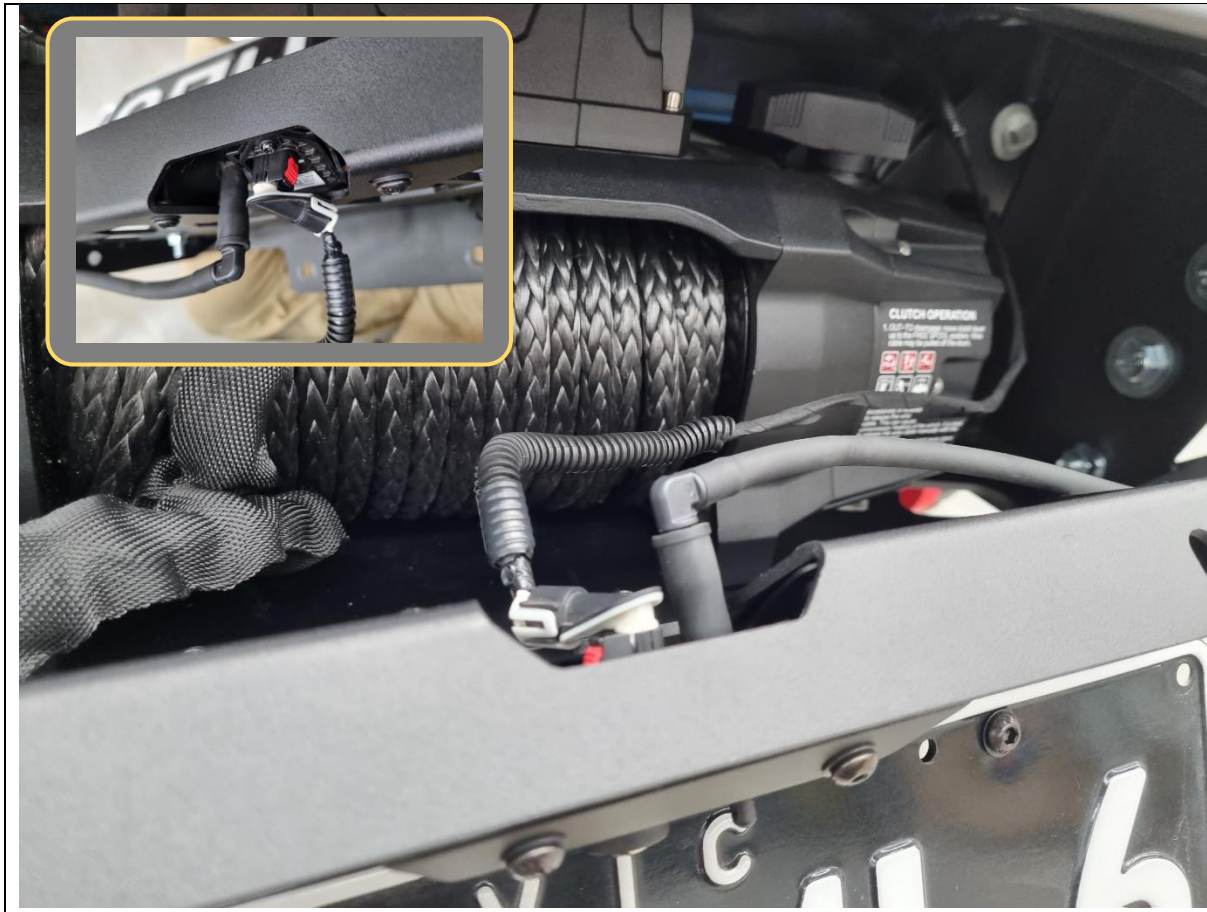

- 143. Hold the mesh fairlead up to the bar and connect the camera harness and washer hose to the back of the camera housing.
- 144. Feed winch cable through the hawse fairlead if applicable.

**TOOLS REQUIRED**

**FASTENERS**



- 145. Fit the mesh fairlead mount to the centre of the bar, using 2x M8x16 black button head bolts (top), 2x M8x20 hex head bolts (bottom) and 4x flat washers.
- 146. Tighten fasteners using 13mm socket/spanner and 5mm hex/Allen key.

**TOOLS REQUIRED**

13mm socket/spanner  
5mm hex/Allen key

**FASTENERS**

2x M8x16 black button head  
2x M8 black flat washer

2x M8x20 hex head  
2x M8 flat washer



- 147. Fit the centre bash plate to the bar using 4x M8x20 black button bolts and flat washers.
- 148. Secure the back of the centre bash plate to the chassis mount bracket using 2x M10x25 hex bolts, flat washers and flange nuts (see inset).

**TOOLS REQUIRED**

- 5mm hex/Allen key
- 16mm socket/spanner

**FASTENERS**

- 4x M8x20 black button head
- 4x M8 black flat washer
- 2x M10x25 hex bolt
- 2x M10 flat washer
- 2x M10 flange nut



149. Fit the lower bash plate to the vehicle by re-using the 4x 13mm hex bolts from Step 34.

Fit the rear 2x bolts through the factory under shield.

Fit the front 2x bolts through the chassis rail.

150. Secure the front lip of the lower bash plate to the centre bash plate with 3x M6x20 hex bolts, flat washers and flange nuts. Insert flange nuts through the hole cutouts in the lower base plate.

**TOOLS REQUIRED**

10mm socket  
13mm socket

**FASTENERS**

4x factory 13mm hex bolt  
  
3x M6x20 hex bolt  
3x M6 flat washer  
3x M6 flange nut



151. Loosely fit the side underpanel mount bracket to the side underpanel with 1x M8x16 black button head bolt, black flat washer and flange nut (see bottom right). Leave finger tight at this stage.
152. Loosely fit the side underpanel to the bar with 5x M6x16 black button head bolts and black flat washers.
153. Loosely fit the side underpanel mount bracket to the chassis with 2x factory 15mm hex bolts retained from Step 24 (see bottom left).
154. Repeat for other side underpanel.

**TOOLS REQUIRED**

4mm hex/Allen key  
5mm hex/Allen key  
15mm socket

**FASTENERS**

4x factory 15mm hex bolt  
10x M6x16 black button head  
10x M6 black flat washer  
2x M8x16 black button head  
2x M8 black flat washer  
2x M8 flange nut





155. Using the edge of the side underpanel as a guide, mark the wheel arch liner, approximately 10mm below the side underpanel.
156. Cut along the marked line with a utility knife.
157. Tuck the wheel arch liner behind the flange of the side underpanel.
158. Tighten all side underpanel bolts and repeat for other side.

**TOOLS REQUIRED**

- Utility knife
- 4mm hex/Allen key
- 5mm hex/Allen key
- 15mm socket

**FASTENERS**



<p>159. Fit the Offroad Animal logo plate to the front of the vehicle as shown.</p> <p>160. Fit the compliance plate in a visible location on the underside of the bar. We recommend placing it on the bottom of the centre bash plate.</p>	<p><b>TOOLS REQUIRED</b></p> <p>5mm hex/Allen key</p>
<p>161. <b>Toro only.</b> If required, fit the supplied antenna mounting brackets to the back of the bar, and secure with 2x M8x20 black button head bolts and black washers, each.</p> <p>162. <b>Toro only.</b> Else fit the 2x M8x20 black button head bolts and black washers to the back of each bullbar upright, to protect nut threads in bar for future use.</p> <p>163. Review fitment and double check all bolts are tightened correctly.</p>	<p><b>FASTENERS</b></p> <p>4x M8x20 black button head 4x M8 flat washer</p>



**Congratulations! You're done!**  
**Head for the tracks and enjoy your newly protected Silverado!**