



FORD RANGER NEXT GEN / VOLKSWAGEN AMAROK NF MY2022 ON ROCK SLIDERS

IMPORTANT! – READ BEFORE INSTALLATION

- When installed in accordance with these instructions, the front protection bar does not affect the operation of the vehicles SRS airbags.
- This product must be installed exactly as per these instructions using only hardware supplied.
- Take a few moments to read instructions thoroughly before beginning work.
- In the event of damage to any bar component please contact OFFROAD ANIMAL to arrange repair/replacement of components.
- Do not use this product for any vehicle make or model other than that specified on these instructions.
- Do not remove labels from this product.
- This product and its fixings must not be modified in any way unless stated in these fitting instructions.
- The installation of this product is recommended for trained personnel.
- These instructions are correct at time of publication. OFFROAD ANIMAL cannot be held responsible for the impact of any changes subsequently made by the vehicle manufacturer. If you find something has changed please contact us to let us know!
- During installation it is the duty of the installer to check correct operation/clearances of all components.
- If Instructions are to be printed for reference in the workshop, it is recommended that they are printed in colour, for best legibility.
- Fitting time estimated 1-2 hours

PARTS LISTING

IMPORTANT: Check all parts are present before beginning work! Contact OFFROAD ANIMAL if something is missing.

Main Parts – In the Box

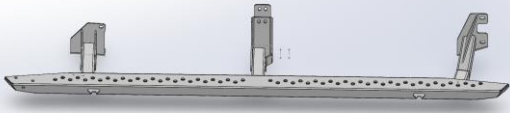
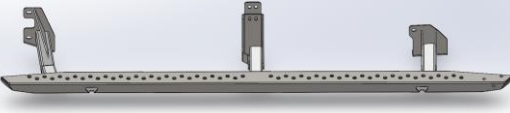
Qty	Part Number	Description	Image
1	RSW-FRA-NG-22-ASM1L	Ranger Next Gen - Steel Slider Step Weldment	
1	RSW-FRA-NG-22-ASM1R	Ranger Next Gen - Steel Slider Step Weldment	

Small Parts – Contained in Small Parts Kit Bag

Qty	Part Number	Description
10	BP-COM-M10X30-250-ASM0	Bolt Plate M10X30, 250mm stem
4	NP-COM-M10-170-ASM0	M10 LOLLYPOP NUT PLATE 170MM LONG
12	M10 FLANGE NUT	Flange Nut, M10x1.5 G8.8 ZP
2	M10 FW LHD	WASHER, FLAT M10X28.5X2.5
4	M10 x 30	Bolt Hex, M10X30x[1.5], GR8.8 ZP
4	M10 x 110	Bolt Hex, M10X110x[1.5], GR8.8 ZP
4	M10 Flat Washer	M10 FW
6	M8 HD FLAT WASHER - BZP	M8 FLAT WASHER - High Tensile 19x8x2mm, ISO4042 ZnNi BLACK PASSIVATED FINISH
6	M8 X 20 BHCS BLACK ZINC	SCREW, BUTTON HEAD CAP, M8X20X1.25, ISO4042 ZnNi BLACK PASSIVATED FINISH

TOOLS REQUIRED

The following tools will be required to install the product.

Hand Tools	Power Tools	Workshop Equipment
Metric Socket Set 8-19mm Socket Extension Bar Metric Spanner Set 10-19mm Hex (Allen) Key Set 4-6mm Trim Puller Tool Flat Blade Screwdriver set Phillips Head Screwdriver set Utility Knife Side Cutters	Electric/Air Impact Driver (Optional)	Hydraulic Lift Trolley

WORKSHOP SAFETY

It is the responsibility of the installer to always complete works in a safe manner. Make sure the following safety equipment is available and precautions are observed whilst fitting this product.

<p>Hearing Protection</p> 	<p>Always wear ear protection when using power tools.</p>
<p>Eye Protection</p> 	<p>Ensure eye protection is always worn when cutting or drilling.</p>
<p>Manual Handling</p> 	<p>Do not attempt to lift bar assemblies or rock sliders on your own.</p> <p>Always use two people to lift or use mechanical Lifting aid such as hydraulic lifting trolley.</p>
<p>Vehicle Support</p> 	<p>Always ensure vehicle is properly supported when working on it. Do not attempt to fit products whilst suspension work is being carried out. Do not work under a vehicle supported only by a jack.</p>

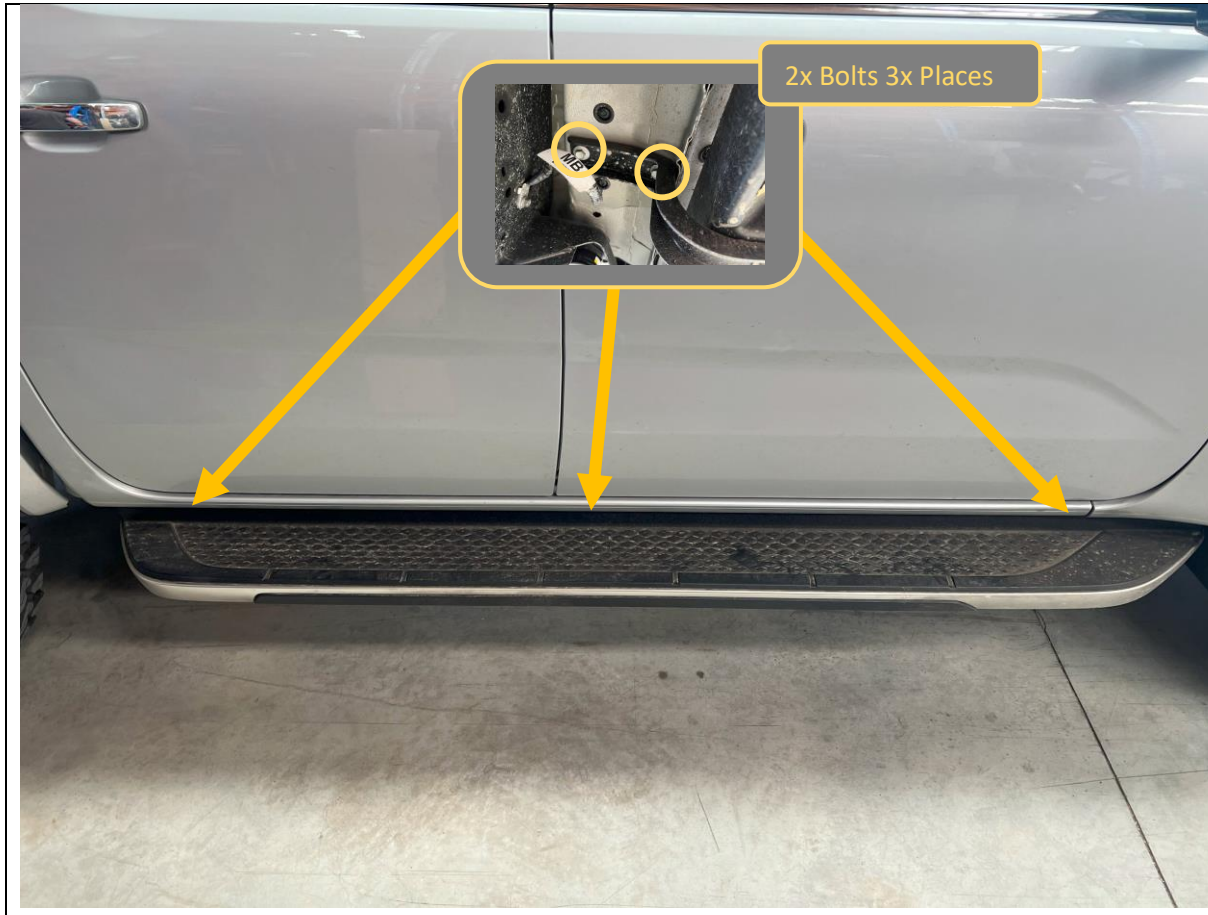

1. Remove Factory side steps if fitted by removing the 6x Bolts (2 Per mount) securing them to the body using a 12mm socket.
2. Discard Factory steps and bolts.

TOOLS REQUIRED
12mm socket

FASTENERS
6x Factory Flange head
Bolts
(per side)

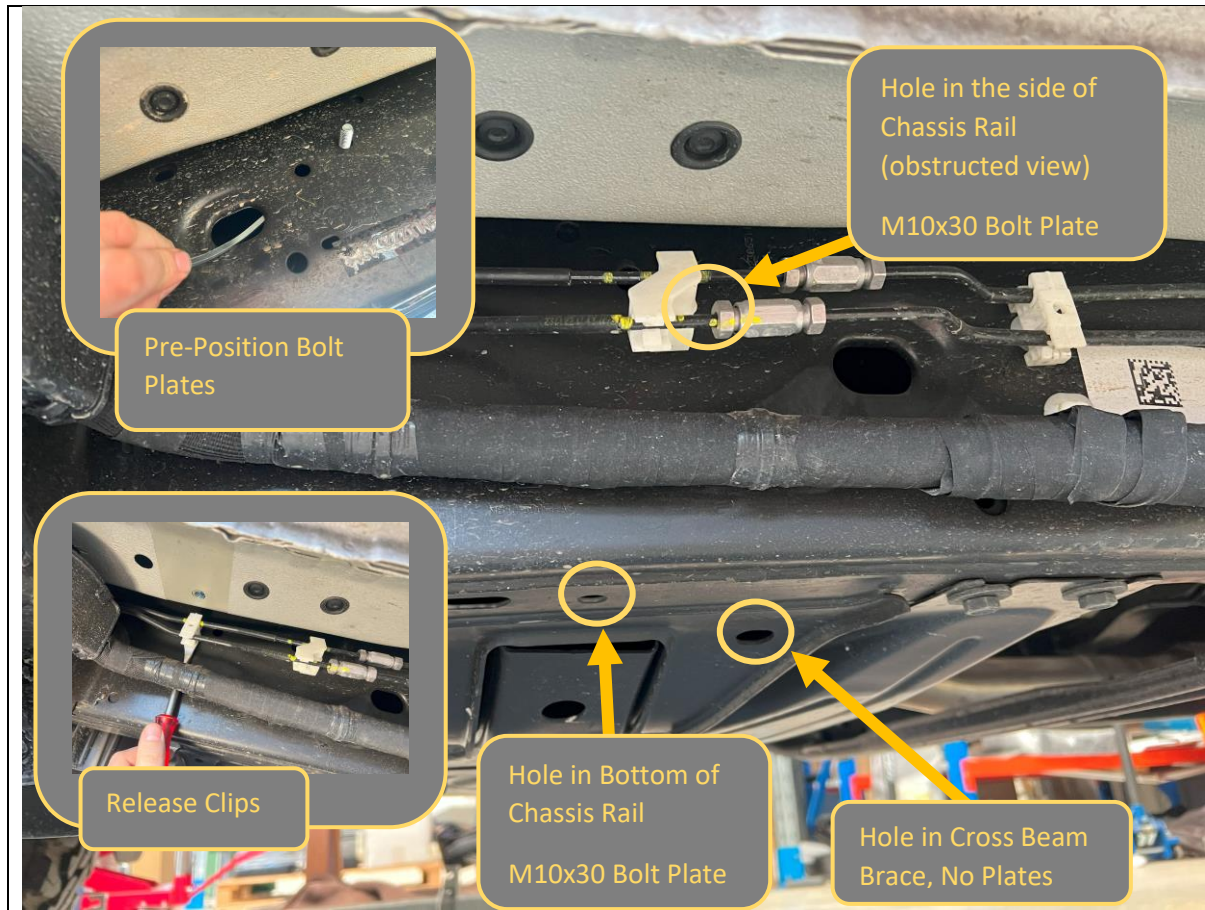

3. Starting on LHS of vehicle Locate features that front mount mounts to, referring to image above.
4. Using a trim tool release the plastic clips securing the hard hoses and wiring harness to the side of the chassis rail to allow extra space to work.
5. Pre-Position the Bolt Plates for the Front Mounts in the locations shown. Bend the stems to allow the plates to be manipulated to the correct positions.

TOOLS REQUIRED

Trim Tool

FASTENERS

2x M10x30 Bolt Plate

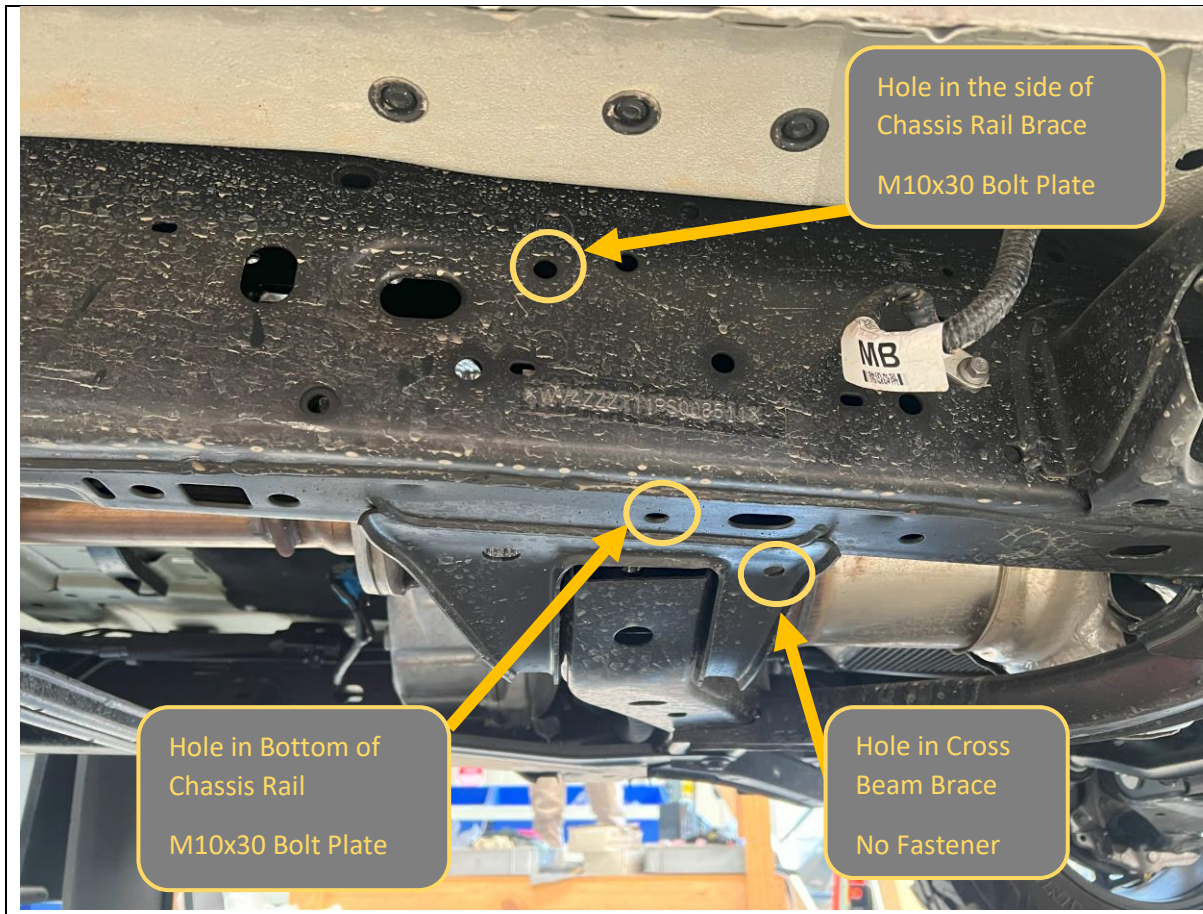

6. Repeat on RHS of vehicle Locate features that front mount mounts to, referring to image above.
7. Pre-Position the Bolt Plates for the Front Mounts in the locations shown. Bend the stems to allow the plates to be manipulated to the correct positions.

TOOLS REQUIRED

Trim Tool

FASTENERS

2x M10x30 Bolt Plate

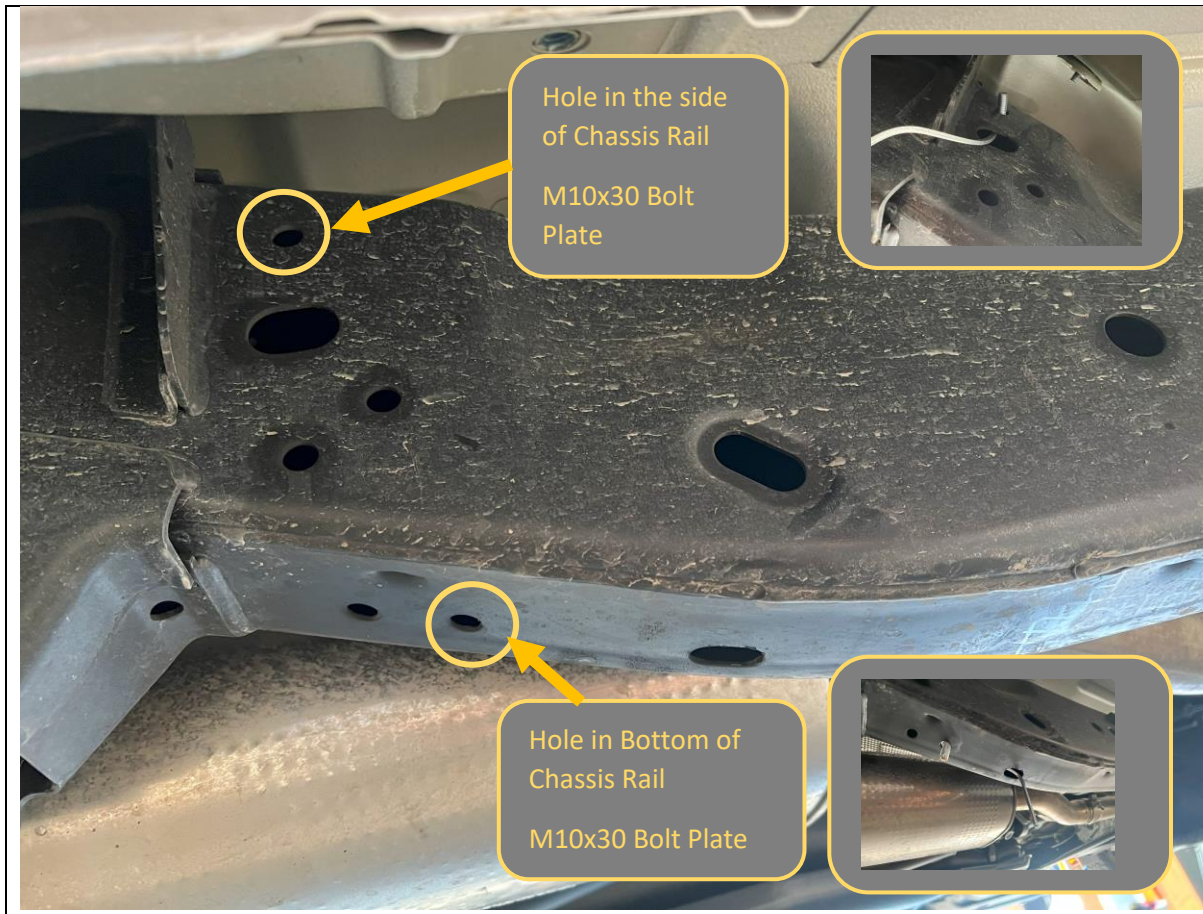

8. Locate the features for the rear mount in the chassis, just forward of the leaf spring hanger as annotated in the image above
9. Feed in Bolt plate for the bottom mount, using slot in the bottom of chassis, and align with the holes
10. Feed in bolt plate for the top mount, using large hole in the side of chassis towards body mount, and position with thread protruding through the hole.
11. Repeat on both sides of vehicle.

TOOLS REQUIRED

FASTENERS

2x M10x30 Bolt Plate

Per Side



12. Unpack welded slider assembly and position on lifting trolley such that mounts sit approximately level.

TOOLS REQUIRED

Lifting Trolley

FASTENERS



Manipulate bolt plates + Slider to align mounts with Vehicle Chassis

13. With assistance from another person fit the slider to the vehicle and secure to pre-positioned bolt plates with M10 Flange Nuts.

14. We find the best way to achieve this is to have one person underneath the car to manipulate the mounts and nut / bolt plates into position and a second person to assist support and position the slider assembly. It is necessary to move the slider inwards first and then up to the final position.

NOTE: The preplaced bolt plates will need to be manipulated back into the chassis momentarily to allow the slider to move up into the correct position.

15. Ensure the sliders sit directly against the chassis rail and do not pinch or trap any electrical harnesses or fluid lines.

TOOLS REQUIRED

Lift Trolley
Patience
Finger Dexterity

FASTENERS

4x M10 Flange Nut



16. Once secure, finish front mount installation securing final mounting point with M10x30 Bolt, HD Flat Washer, and Flange Nut.

TOOLS REQUIRED

- FASTENERS**
 1x M10 x30 Bolt
 1x M10x30 HD Washer
 1x M10 Flange Nut

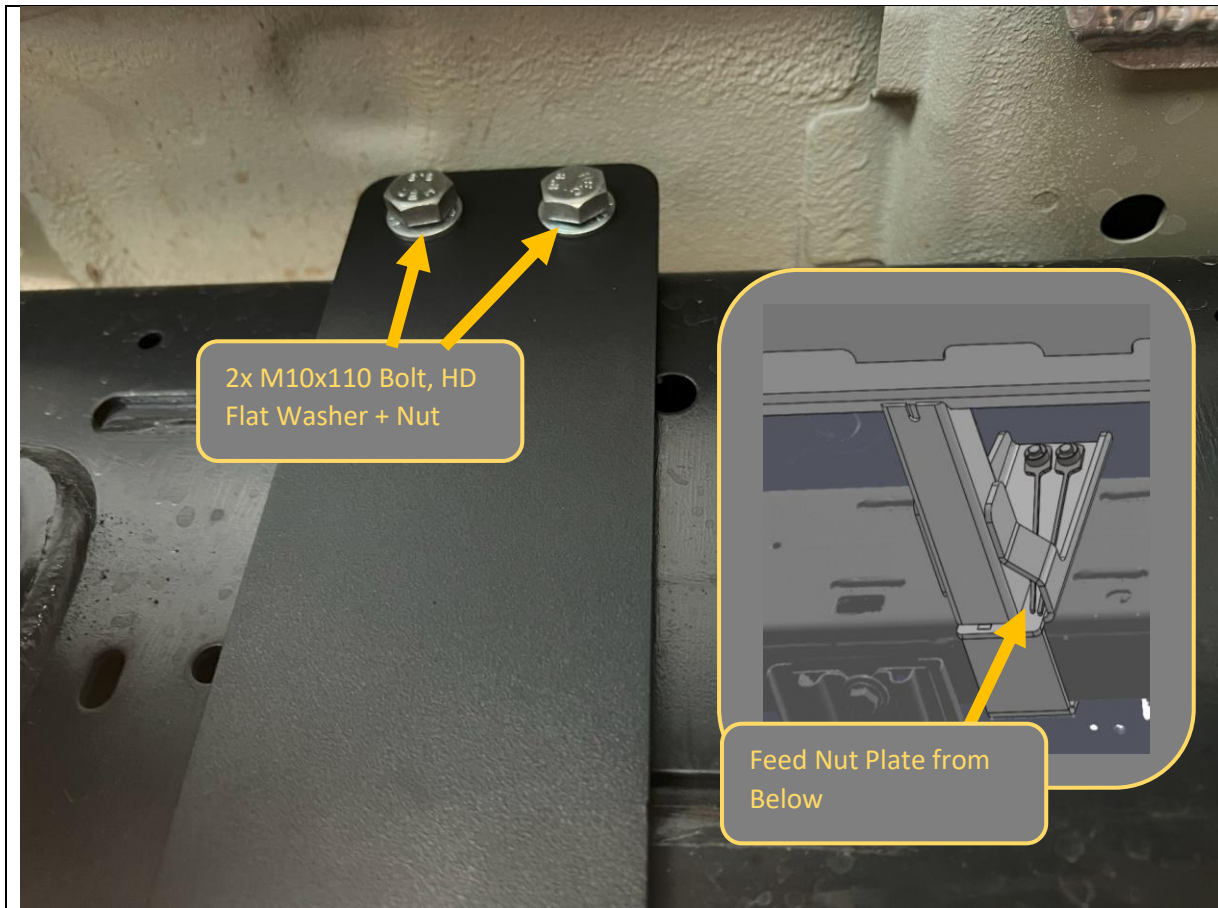

- 17. Secure center mount using 2x M10x110mm bolts, Flat washers, and Nut plates. Fit bolts from the inside of the chassis rail.
- 18. Feed nut plates from below on side where nut location is obstructed by body

TOOLS REQUIRED

FASTENERS

- 1x M10 x110 Bolt
- 1x M10HD Washer
- 1x M10 Nut Plate

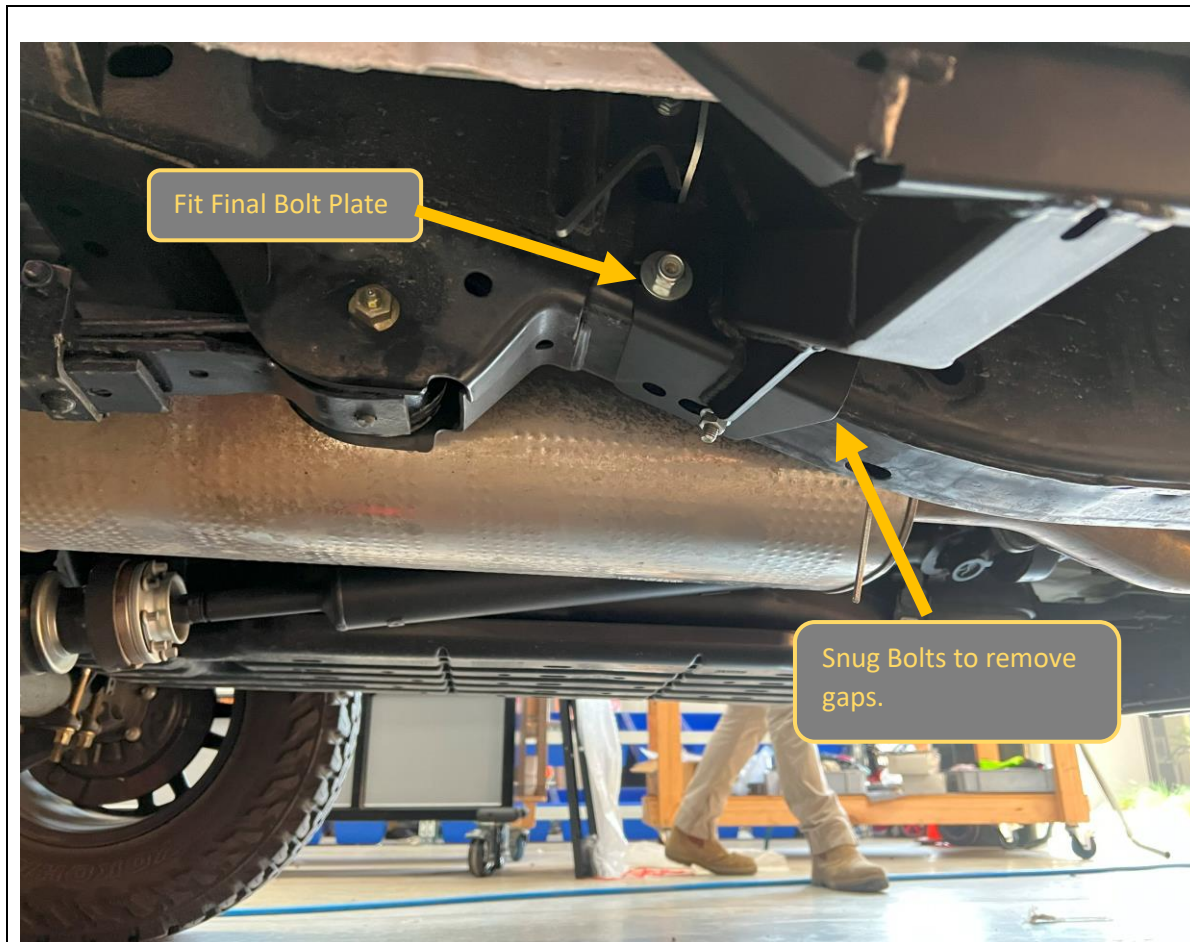

<p>19. Finish Rear mount installation securing final mounting point with M10x30 Bolt plate, and Flange Nut.</p> <p>20. Snug all mount bolts, first on the bottom, then on the side to pull mounts toward chassis. Ensure mounts are sitting against chassis rails.</p> <p>21. Fully tighten mounting bolts, Starting on bolts on the bottom of chassis, then on the side of chassis.</p>	<p>TOOLS REQUIRED</p> <p>15-16mm Spanner/Socket</p>
	<p>FASTENERS</p>



- 22. Check that step is sitting level to body / chassis. If the step is not level, it is likely that bolts were tightened out of sequence and mounts are not sitting flat against the chassis. To remedy loosen bolts and Repeat Steps 20 and 21.
- 23. Repeat slider fitting steps 12-21 for the other side of the vehicle.

TOOLS REQUIRED
15/16mm socket / spanner

FASTENERS

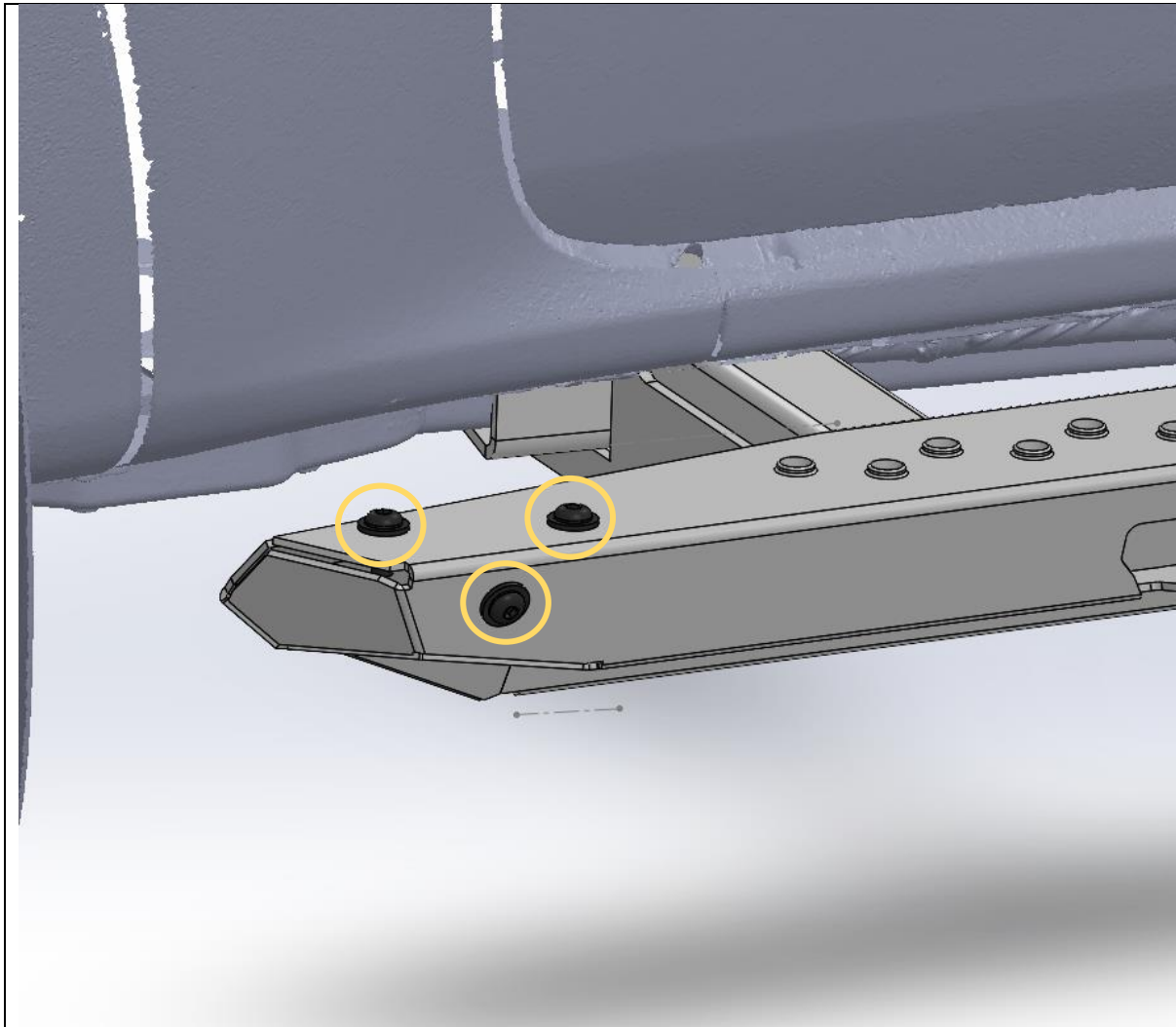

- 24. If also fitting Side rails to car equipped with a Toro bulbar do so now, follow instructions supplied with the side rail kit.
- 25. If not fitting side rails, fit the supplied M8x20 Black Buton head bolts and Black Washers to cover side rail attachment threads on front end of the slider step.
- 26. Double Check all fasteners are tight, and you are done!

TOOLS REQUIRED

5mm Hex Key

FASTENERS

3x M8x20 Black Button Head
3x Black M8 Washer



Congratulations!
Head for the tracks and enjoy your newly protected Ranger / Amarok!