



## RAM 2500/3500 DJ2 Predator & Toro Front Bar Fitting Instruction

### **IMPORTANT! – READ BEFORE INSTALLATION**

- When installed in accordance with these instructions, the front protection bar does not affect the operation of the vehicles SRS airbags.
- This product must be installed exactly as per these instructions using only hardware supplied.
- Take a few moments to read instructions thoroughly before beginning work.
- In the event of damage to any bar component please contact OFFROAD ANIMAL to arrange repair/replacement of components.
- Do not use this product for any vehicle make or model other than that specified on these instructions.
- Do not remove labels from this product.
- This product and its fixings must not be modified in any way unless stated in these fitting instructions.
- The installation of this product is recommended for trained personnel.
- These instructions are correct at time of publication. OFFROAD ANIMAL cannot be held responsible for the impact of any changes subsequently made by the vehicle manufacturer. If you find something has changed, please contact us to let us know!
- During installation it is the duty of the installer to check correct operation/clearances of all components.
- If Instructions are to be printed for reference in the workshop, it is recommended that they are printed in colour, for best legibility.

# PARTS LISTING



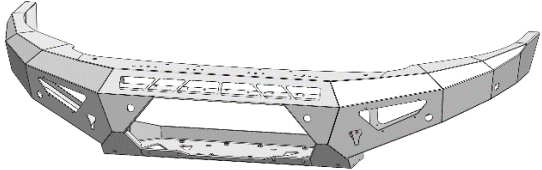
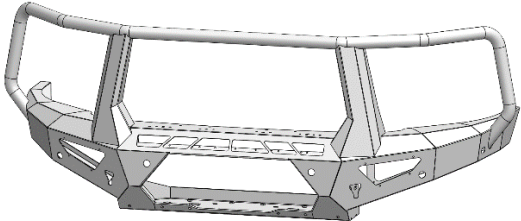
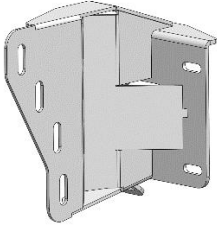
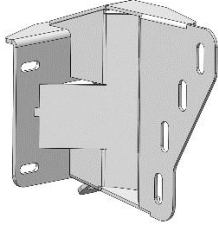
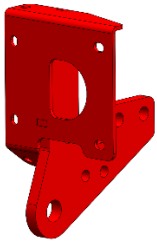

**IMPORTANT:** Check all parts are present before beginning work! Contact OFFROAD ANIMAL if something is missing.

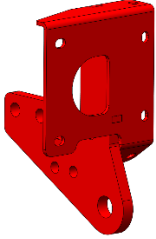
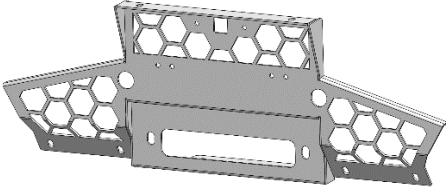
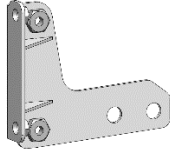
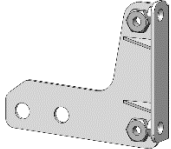
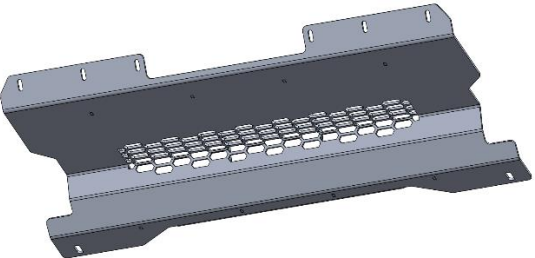
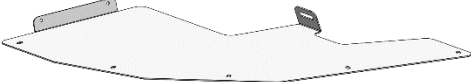
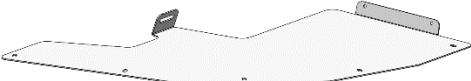
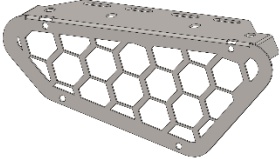
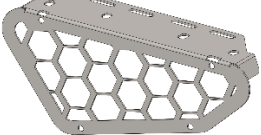
## Parts List

Qty	Part Number	Description	Image
<b>PREDATOR ONLY</b>			
<b>1</b>	FB-R25-DJ2-19-PR-ASM1	RAM 2500 DJ2 Predator Welded Assembly	
<b>TORO ONLY</b>			
<b>1</b>	FB-R25-DJ2-19-TOR-ASM1	RAM 2500 DJ2 Toro Welded Assembly	
<b>1</b>	FB-R25-DJ2-19-PR-ASM2R	RAM 2500 DJ2 Impact Assy	
<b>1</b>	FB-R25-DJ2-19-PR-ASM2L	RAM 2500 DJ2 Impact Assy	
<b>1</b>	FB-R25-DJ2-19-PR-ASM3R	RAM 2500 DJ2 Tow Point Welded Assy	

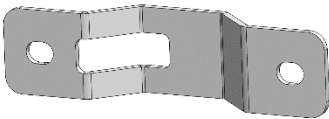
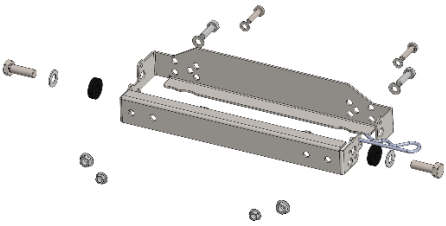
1	FB-R25-DJ2-19-PR-ASM3L	RAM 2500 DJ2 Tow Point Welded Assy	
1	FB-R25-DJ2-19-PR-ASM4	RAM 2500 DJ2 Mesh Fairlead Welded Assy	
1	FB-R25-DJ2-19-PR-ASM5R	RAM 2500 DJ2 Chassis Brace Welded Assy	
1	FB-R25-DJ2-19-PR-ASM5L	RAM 2500 DJ2 Chassis Brace Welded Assy	
1	FB-R25-DJ2-19-PR-ASM6	RAM 2500 DJ2 Bash Plate Welded Assy	
1	U-0069R	RAM 2500 DJ2 Side Underpanel	
1	U-0069L	RAM 2500 DJ2 Side Underpanel	
<b>PREDATOR ONLY</b>			
1	M-0002R	Light Cover Mesh	
1	M-0002L	Light Cover Mesh	

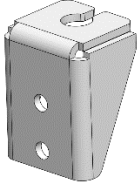
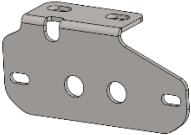
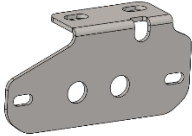
<b>TORO ONLY</b>			
<b>1</b>	M-00030R	Wing Mesh Panel - Toro With Indicator Repeater	
<b>1</b>	M-00030L	Wing Mesh Panel - Toro With Indicator Repeater	
<b>1</b>	B-1008R	RAM 2500 DJ2 Halo Fog Light Bracket	
<b>1</b>	B-1008L	RAM 2500 DJ2 Halo Fog Light Bracket	
<b>1</b>	B-1011R	RAM 2500 DJ2 Bash Plate Mount	
<b>1</b>	B-1011L	RAM 2500 DJ2 Bash Plate Mount	
<b>1</b>	B-1015	RAM 2500 DJ2 Winch Strap	
<b>2</b>	B-1016	RAM 2500 DJ2 Pan Brace	

1	B-1017	RAM 2500 DJ2 Camera Relocation Bracket	
1	NPF-COM-SM- ASM0	Number Plate Flip ASM Small	
1	FB-R25-DJ2-19- PR-ADRCP	ADR Compliance Plate RAM 2500 DJ2	
1	OFA-LOGO	Offroad Animal Metal Logo	
1	FI Note	Fitting Instruction Note	N/A
<b>TORO ONLY</b>			
2	B-0649	Toro Antenna Bracket – 90 Degree Tall	
1	B-0797R	Toro Indicator Repeater Bracket	
1	B-0797L	Toro Indicator Repeater Bracket	
1	11CAT1M-2	LED Autolamps 11CAT1M-2 Front Indicator - Twin Blister Pack	

**PREDATOR Fasteners – Contained in Small Parts Kit Bag**

Qty	Part Number	Description
8	M4X12 PAN	SCREW, PAN HEAD PHILLIPS, M4X12X0.7 GR4.6 ZP
8	M4 FLAT WASHER	Flat Washer M4, 8mmODx0.8mm T
8	M4 FLANGE NUT	Flange Nut, M4
30	M6x16 BHCS BLACK ZINC	SCREW, BUTTON HEAD CAP, M6X16X1 GR12.9, ISO4042 ZnNi BLACK PASSIVATED FINISH
30	M6 FLAT WASHER BLACK ZINC	M6 Flat Washer, 12x6.1x1, ISO4042 ZnNi BLACK PASSIVATED FINISH
20	M6 FLANGE NUT	Flange Nut, M6x1 G8.8 ZP
10	M6CN3MM	CAGE NUT M6x2.6-3.5
2	M8 X 16 BHCS BZP	SCREW, BUTTON HEAD CAP, M8X16X1.25 GR12.9, ISO4042 ZnNi BLACK PASSIVATED FINISH
6	M8 X 25 BHCS BLACK ZINC	SCREW, BUTTON HEAD CAP, M8X25X1.25, ISO4042 ZnNi BLACK PASSIVATED FINISH
4	M8 X 12 HEX	Bolt Hex, M8X12x1.25, GR8.8 ZP
8	M8 X 20 HEX	Bolt Hex, M8X20x1.25, GR8.8 ZP
8	M8 FLAT WASHER- BLACK ZINC	M8 FLAT WASHER, 16.5x8.4x1.2, ISO4042 ZnNi BLACK PASSIVATED FINISH
4	M8 FLAT WASHER	M8 FW
8	M8 HD FLAT WASHER	M8 FLAT WASHER - High Tensile 19x8x1.9mm
6	M8 FLANGE NUT	Flange Nut, M8x1.25 G8.8 ZP
2	M10X25 BHCS	SCREW, BUTTON HEAD CAP, M10X25X1.5 GR12.9 ZP
12	M10 x 30	Bolt Hex, M10X30x[1.5], GR8.8 ZP
4	M10 X 40	Bolt Hex, M10X40X1.5, GR8.8 ZP
2	M10 Flat Washer	M10 FW
16	M10 FW LHD	WASHER, FLAT M10X28.5X2.5
14	M10 FLANGE NUT	Flange Nut, M10x1.5 G8.8 ZP
8	M12X30	Bolt Hex, M12X30x1.75, GR8.8 ZP
4	M12X100	Bolt Hex, M12X100x1.75, GR8.8 ZP
14	M12 FW LHD	M12 FW Large Heavy Duty
8	M12 FLANGE NUT	Flange Nut, M12x1.75 G8.8 ZP
2	M12 Nyloc nut	M12 NYLOC NUT
4	M16 x 110 HEX ZP	Bolt Hex, M16X110X2, GR8.8 ZP
12	M16 FW	M16 FW
4	M16 FLANGE NUT	Flange Nut, M16x2.0 G8.8 ZP
2	BP-COM-M12X30-190-ASM0	Bolt Plate M12X30, 190mm stem

**TORO Fasteners – Contained in Small Parts Kit Bag**

Qty	Part Number	Description
4	M3X12 PAN	SCREW, PAN HEAD PHILLIPS, M3X12X0.5 GR4.6 ZP
4	M3 FLAT WASHER	Flat Washer M3, 7mmODx0.5mm T
4	M3 NUT	Hex Nut, M3x0.5 G48.8 ZP
8	M4X12 PAN	SCREW, PAN HEAD PHILLIPS, M4X12X0.7 GR4.6 ZP
8	M4 FLAT WASHER	Flat Washer M4, 8mmODx0.8mm T
8	M4 FLANGE NUT	Flange Nut, M4
34	M6x16 BHCS BLACK ZINC	SCREW, BUTTON HEAD CAP, M6X16X1 GR12.9, ISO4042 ZnNi BLACK PASSIVATED FINISH
34	M6 FLAT WASHER BLACK ZINC	M6 Flat Washer, 12x6.1x1, ISO4042 ZnNi BLACK PASSIVATED FINISH
22	M6 FLANGE NUT	Flange Nut, M6x1 G8.8 ZP
12	M6CN3MM	CAGE NUT M6x2.6-3.5
2	M8 X 16 BHCS BZP	SCREW, BUTTON HEAD CAP, M8X16X1.25 GR12.9, ISO4042 ZnNi BLACK PASSIVATED FINISH
4	M8 X 20 BHCS BLACK ZINC	SCREW, BUTTON HEAD CAP, M8X20X1.25, ISO4042 ZnNi BLACK PASSIVATED FINISH
6	M8 X 25 BHCS BLACK ZINC	SCREW, BUTTON HEAD CAP, M8X25X1.25, ISO4042 ZnNi BLACK PASSIVATED FINISH
4	M8 X 12 HEX	Bolt Hex, M8X12x1.25, GR8.8 ZP
8	M8 X 20 HEX	Bolt Hex, M8X20x1.25, GR8.8 ZP
12	M8 FLAT WASHER- BLACK ZINC	M8 FLAT WASHER, 16.5x8.4x1.2, ISO4042 ZnNi BLACK PASSIVATED FINISH
4	M8 FLAT WASHER	M8 FW
8	M8 HD FLAT WASHER	M8 FLAT WASHER - High Tensile 19x8x1.9mm
6	M8 FLANGE NUT	Flange Nut, M8x1.25 G8.8 ZP
2	M10X25 BHCS	SCREW, BUTTON HEAD CAP, M10X25X1.5 GR12.9 ZP
12	M10 x 30	Bolt Hex, M10X30x[1.5], GR8.8 ZP
4	M10 X 40	Bolt Hex, M10X40X1.5, GR8.8 ZP
2	M10 Flat Washer	M10 FW
16	M10 FW LHD	WASHER, FLAT M10X28.5X2.5
14	M10 FLANGE NUT	Flange Nut, M10x1.5 G8.8 ZP
8	M12X30	Bolt Hex, M12X30x1.75, GR8.8 ZP
4	M12X100	Bolt Hex, M12X100x1.75, GR8.8 ZP
14	M12 FW LHD	M12 FW Large Heavy Duty
8	M12 FLANGE NUT	Flange Nut, M12x1.75 G8.8 ZP
2	M12 Nyloc nut	M12 NYLOC NUT
4	M16 x 110 HEX ZP	Bolt Hex, M16X110X2, GR8.8 ZP
12	M16 FW	M16 FW
4	M16 FLANGE NUT	Flange Nut, M16x2.0 G8.8 ZP
2	BP-COM-M12X30-190-ASM0	Bolt Plate M12X30, 190mm stem

## TOOLS REQUIRED

The following tools will be required to install the product.

<b>Hand Tools</b>	<b>Power Tools</b>	<b>Workshop Equipment</b>
Metric Socket Set 10-19mm	Electric/Air Impact Driver (Optional)	Isopropyl Alcohol
Socket Extension Bar		Rag
Metric Spanner Set 10-19mm	Soldering Iron (Toro Only)	Cable Ties
Hex (Allen) Key Set 4-6mm		Crimp terminals (Toro Only)
Torx Key Set		
Trim Removal Tool		
Plastic Auto Trim Tool Set		
Flat Blade Screwdriver Set		
Phillips Head Screwdriver Set		
Utility Knife		
Side Cutters		
Pliers		
Wire Strippers (Toro Only)		
Crimping Tool (Toro Only)		



# WORKSHOP SAFETY

It is the responsibility of the installer to always complete works in a safe manner. Make sure the following safety equipment is available and precautions are observed whilst fitting this product.

<p>Hearing Protection</p> 	<p>Always wear ear protection when using power tools.</p>
<p>Eye Protection</p> 	<p>Ensure eye protection is always worn when cutting or drilling.</p>
<p>Manual Handling</p> 	<p>Do not attempt to lift bar assemblies or rock sliders on your own.</p> <p>Always use two people to lift or use mechanical Lifting aid such as hydraulic lifting trolley.</p>
<p>Vehicle Support</p> 	<p>Always ensure vehicle is properly supported when working on it. Do not attempt to fit products whilst suspension work is being carried out. Do not work under a vehicle supported only by a jack.</p>



1. Remove the number plate and set aside.

**TOOLS REQUIRED**

**FASTENERS**



2. Remove 1x 10mm hex bolt securing the inner wheel guard to the bumper, on each side.

**TOOLS REQUIRED**

10mm socket/spanner

**FASTENERS**

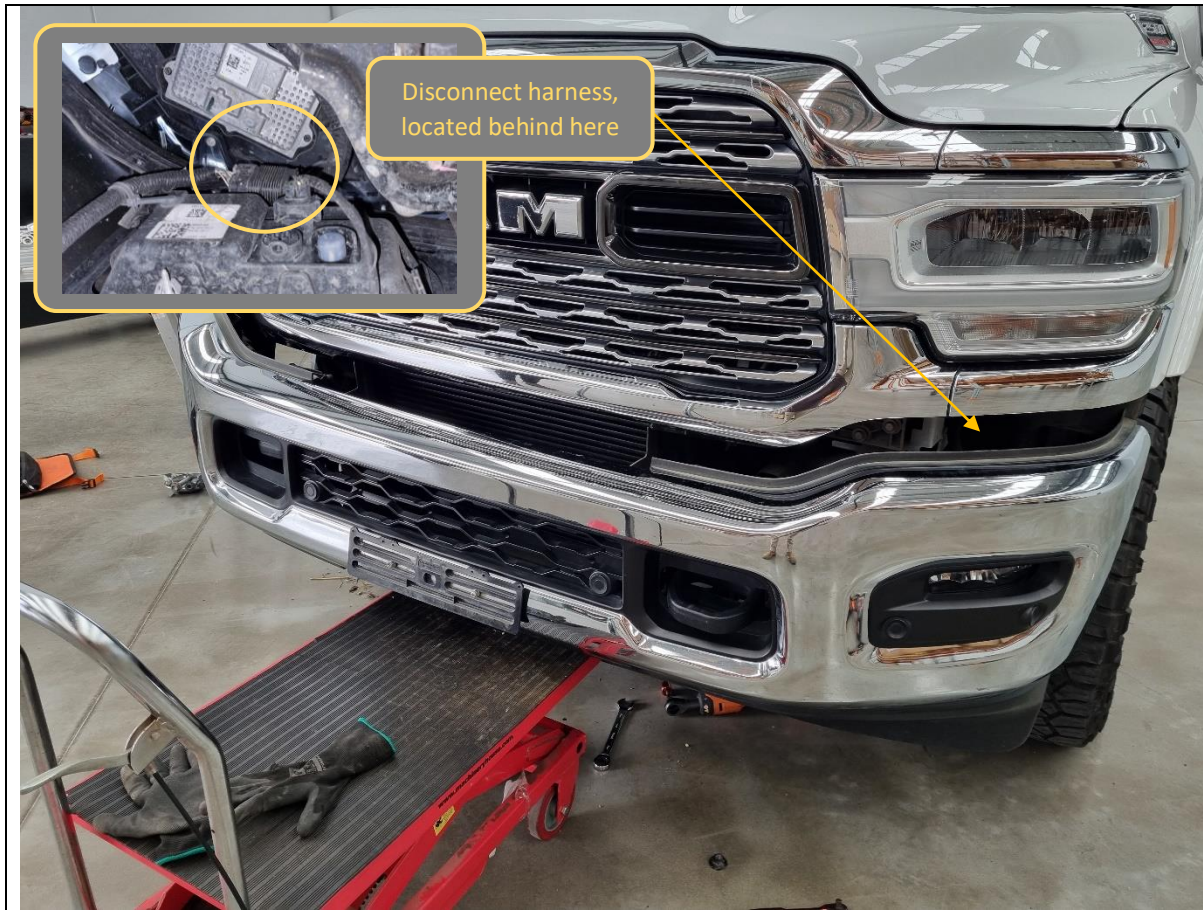

3. Disconnect the bumper wiring harness from inside the bumper on the LH passenger side (driver side for US LHD), above the fog light.
4. Support the bumper with a lifting device (eg. trolley) or friend, before unbolting the bumper in the next step.

**TOOLS REQUIRED**

**FASTENERS**

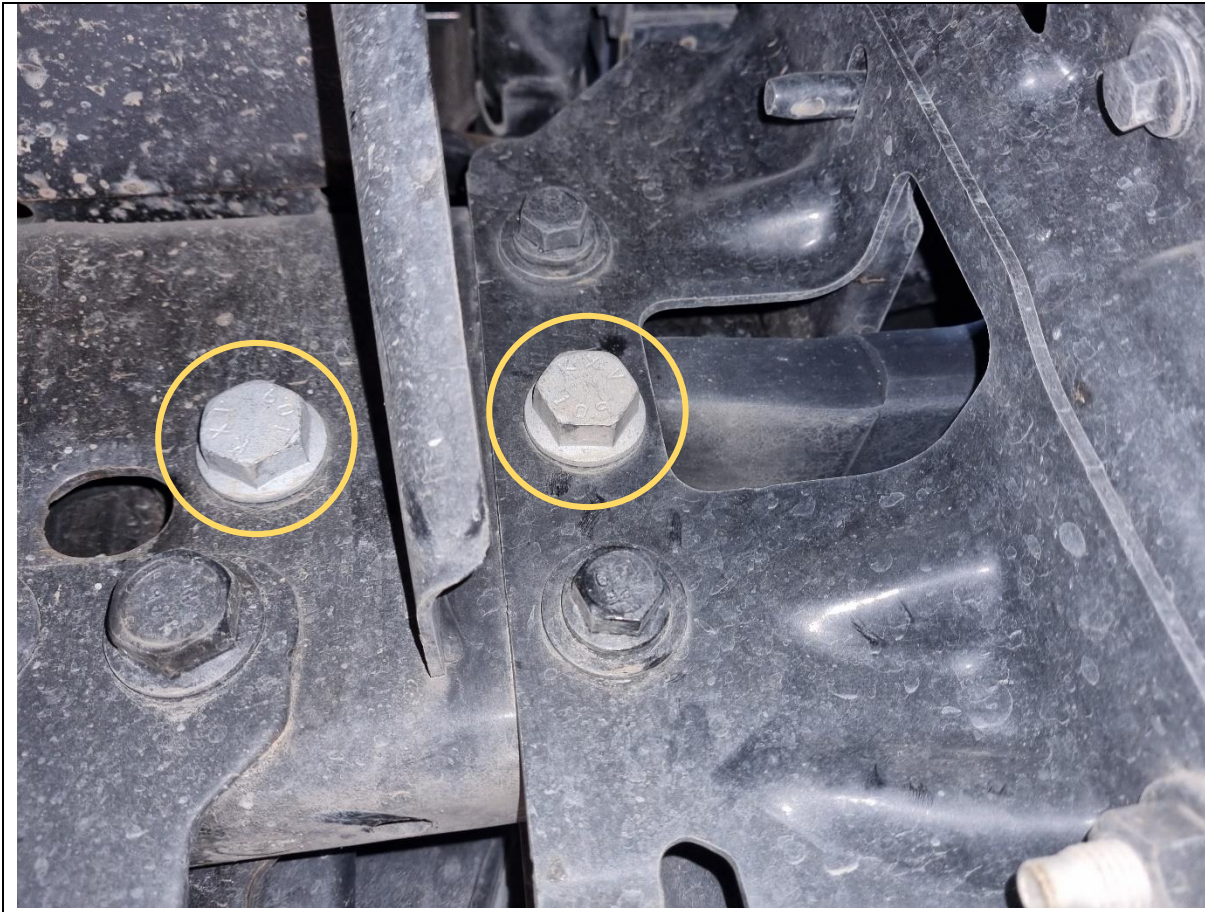

5. From underneath the vehicle, remove 2x 24mm hex head bolts securing the front tow hooks to the chassis, per side.

**TOOLS REQUIRED**

24mm socket/spanner

**FASTENERS**



6. Pull out the loosened tow hooks through the opening in the front of the bumper.

**TOOLS REQUIRED**

**FASTENERS**



7. From underneath the vehicle, remove 2x 19mm hex head bolts securing the steel bumper to the chassis, per side.

**TOOLS REQUIRED**

19mm socket/spanner

**FASTENERS**



8. Pull the bumper off the vehicle and set aside in a safe place.

**TOOLS REQUIRED**

**FASTENERS**



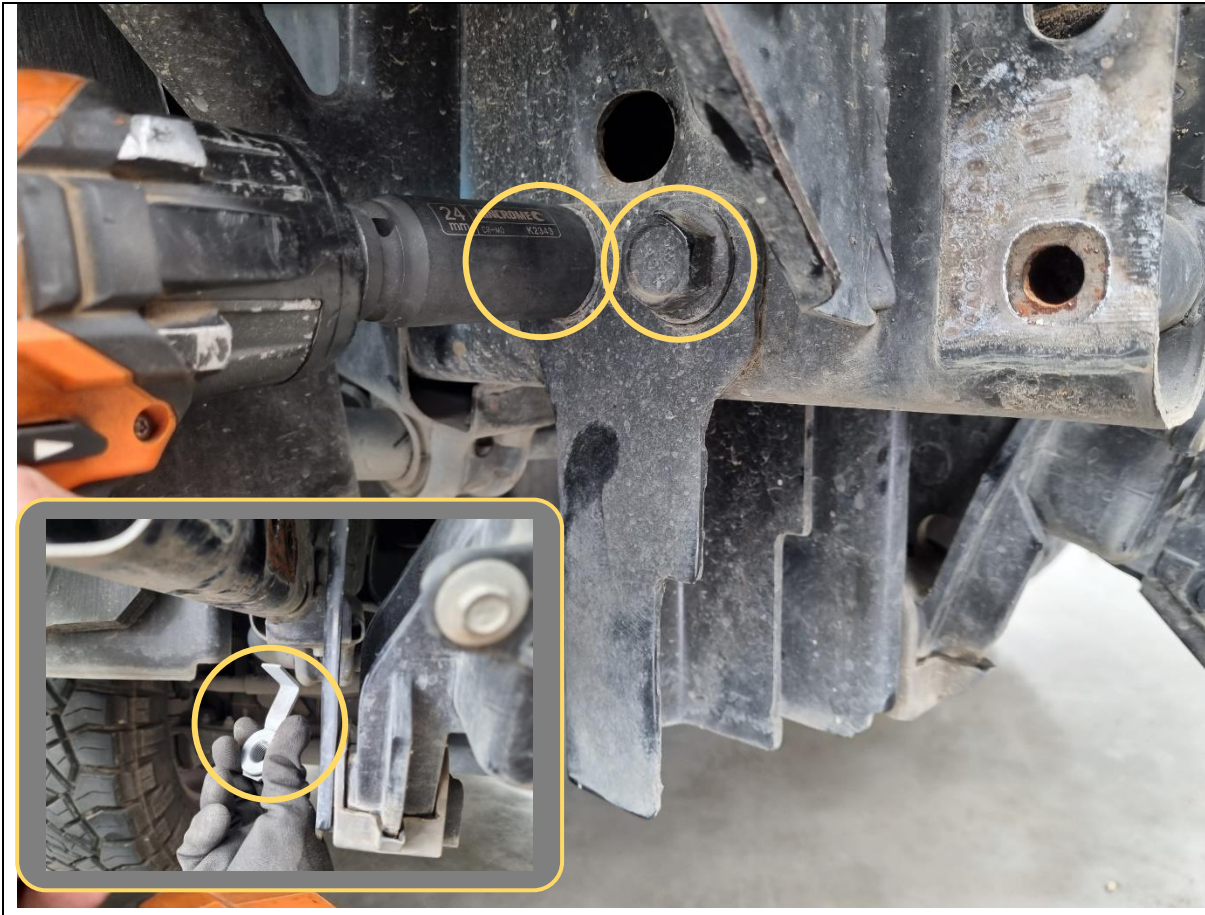

9. Remove 2x 24mm hex head bolts securing the chassis extension brackets to the chassis rail, per side.
10. Also pull out the captive nut plate from the inner face of the chassis rail, in between the chassis and intercooler.

**TOOLS REQUIRED**

24mm socket/spanner

**FASTENERS**



11. Remove 4x 10mm hex head bolts from the front of the intercooler air dam shroud.
12. Also remove 3x plastic push rivets from the bottom of the intercooler air dam shroud. Use a trim tool or flat blade screwdriver to pry the clip out.
13. Remove the intercooler air dam shroud.

**TOOLS REQUIRED**

10mm socket/spanner

Trim tool  
or  
Flat blade screwdriver

**FASTENERS**

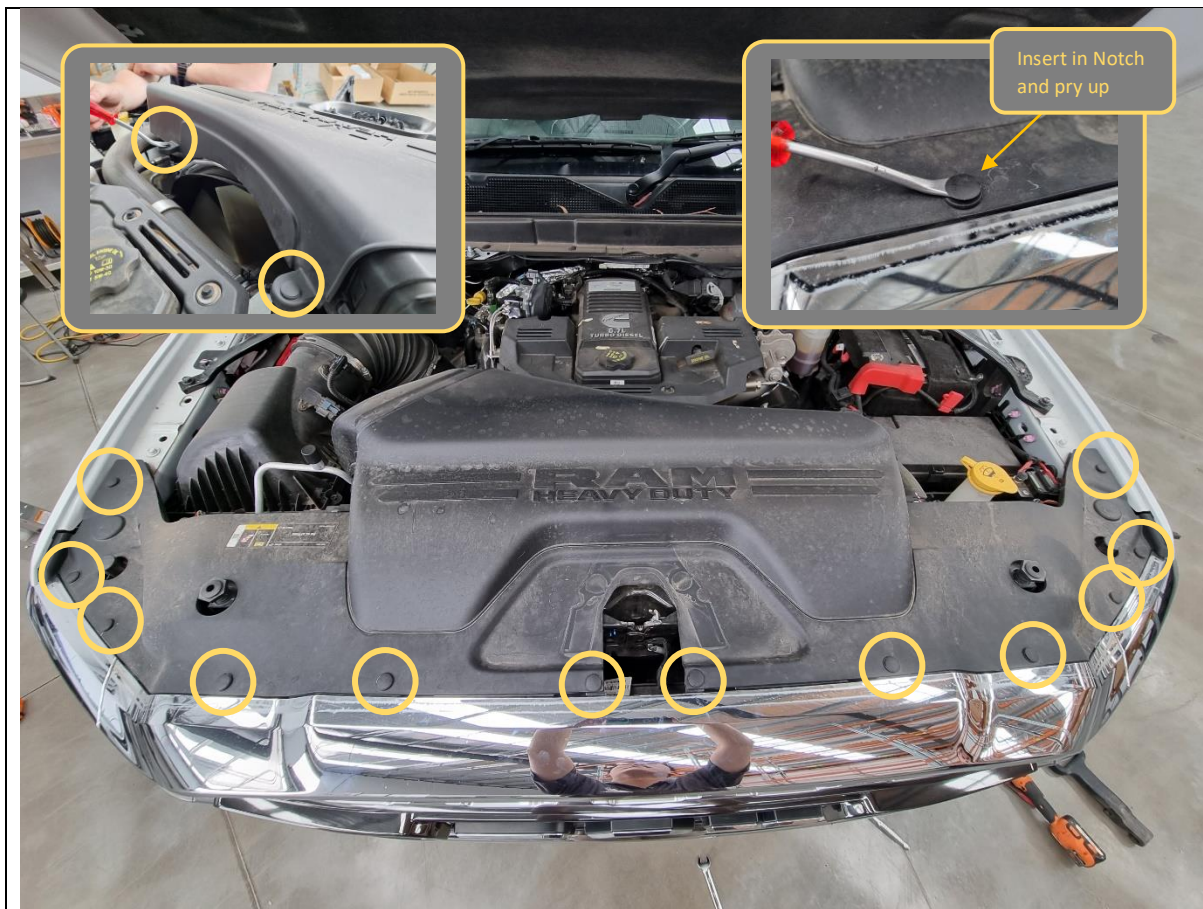

The following steps are for optional relocation of the front 360 camera from the grille to the bar. This is advised if fitting top hoops or driving lights, as they may obscure vision of the camera.

If not relocating the camera, skip to Step 35.

- 14. Open the bonnet.
- 15. Remove 14x plastic push rivets securing the radiator grille cover, by levering centre section upwards using flat bladed screwdriver or trim tool, as shown. Note there are 2x rivets behind near the air intake.

**TOOLS REQUIRED**

Trim tool  
or  
Flat blade screwdriver

**FASTENERS**

14x Plastic Push Rivet  
  
Retain for Reassembly

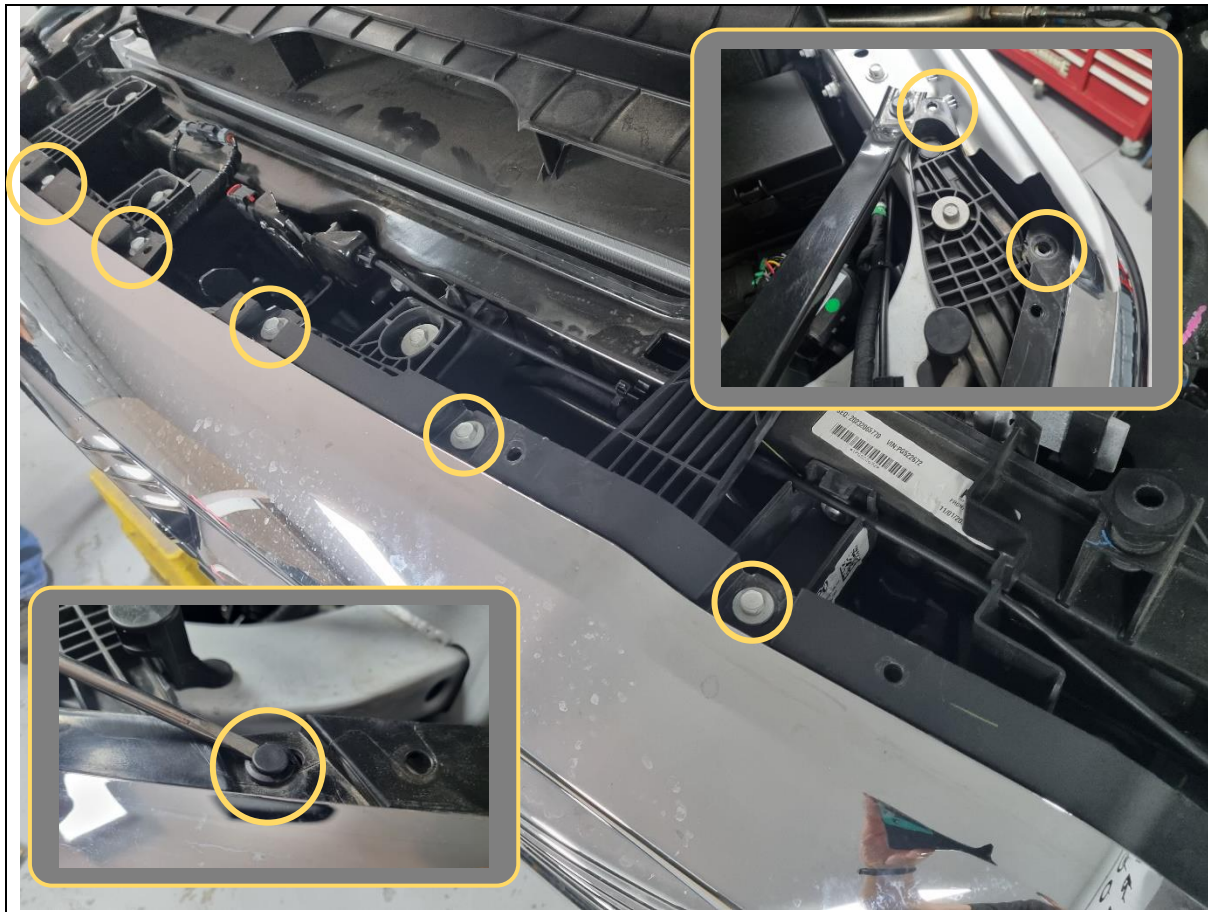

16. Remove 10x 10mm hex bolts securing the top chrome trim to the grille and headlight.

17. Also remove 2x plastic push rivets securing the top chrome trim to the headlights.

**TOOLS REQUIRED**

10mm socket/spanner

Trim tool  
or  
Flat blade screwdriver

**FASTENERS**

10x 10mm hex bolt

2x Plastic Push Rivet

Retain for Reassembly



18. Remove the top chrome trim by pulling forwards and away from the vehicle. Set aside for reassembly.

**TOOLS REQUIRED**

**FASTENERS**

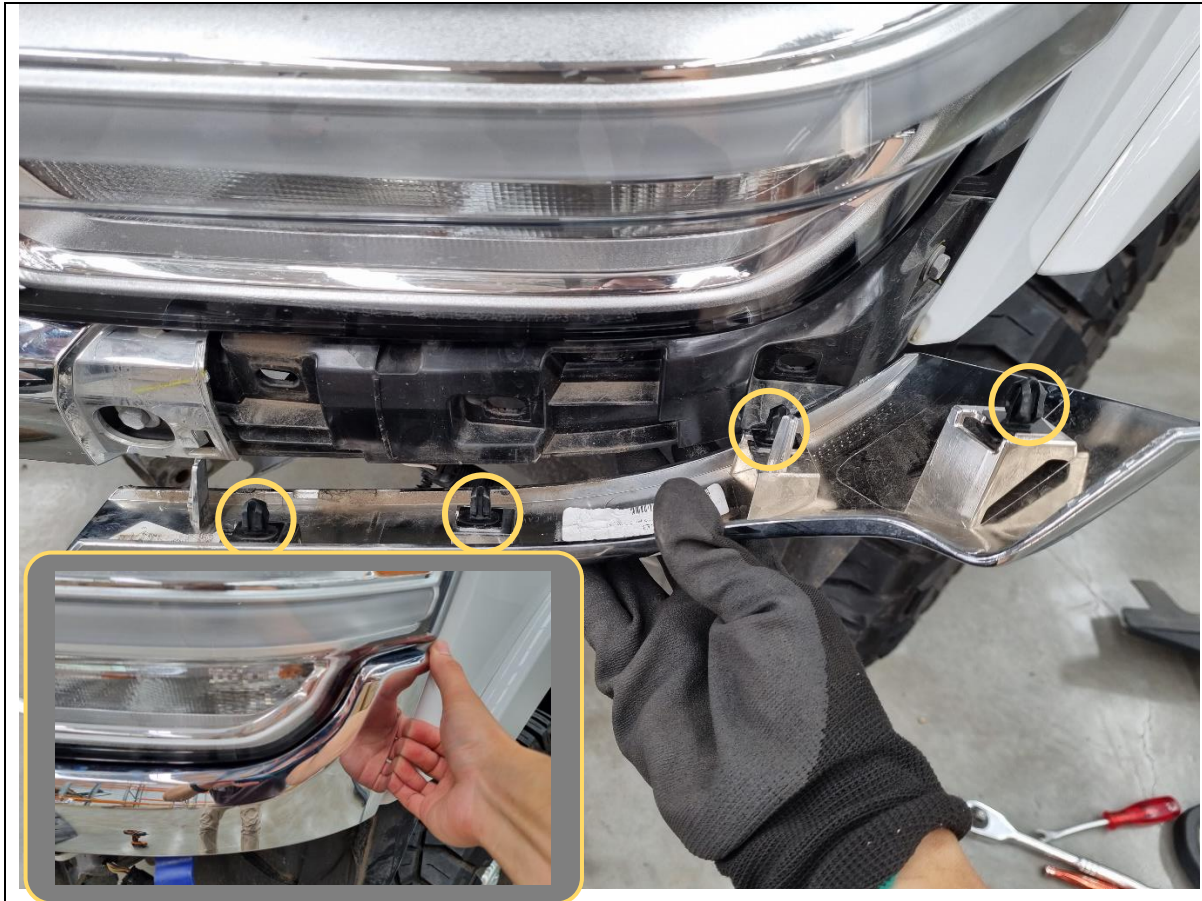

19. Remove the plastic chrome trim beneath the headlights.

The trim is secured by 4x plastic clips (highlighted). Start from the outside edge and carefully pull outwards to release the clips.

20. Set aside for reassembly.

**TOOLS REQUIRED**

**FASTENERS**



21. From underneath the grille, loosen (not fully remove) 7x 10mm hex nuts securing the grille to the vehicle.
22. Remove the 2x 10mm hex bolts securing the bottom outer corners of the bottom chrome trim to the vehicle.

**TOOLS REQUIRED**

10mm socket/spanner

**FASTENERS**

7x 10mm hex nuts

2x 10mm hex bolts

Retain for reassembly



23. Remove the bottom chrome trim by pulling forwards and away from the vehicle. Set aside for reassembly.

**TOOLS REQUIRED**

**FASTENERS**



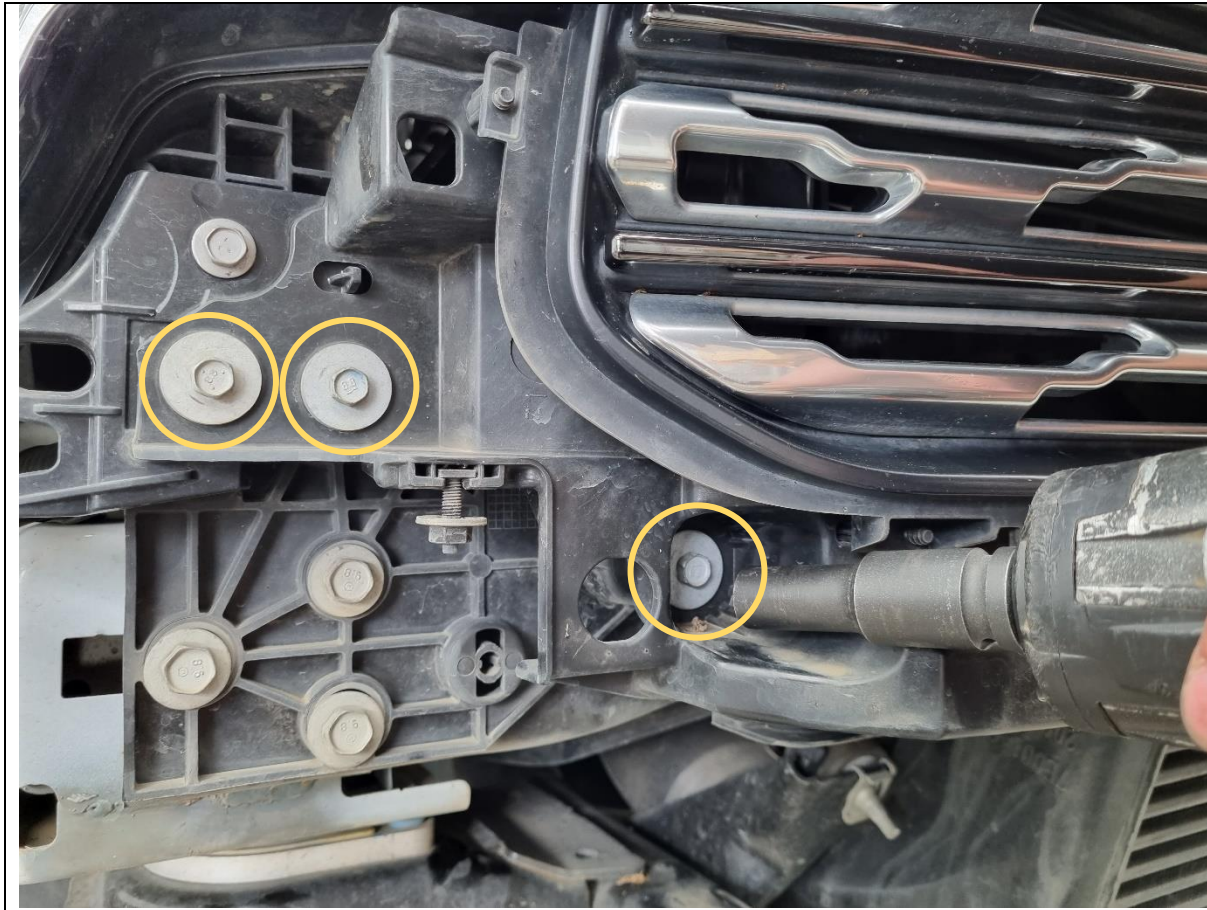

24. Remove the 6x 10mm hex bolts (3x per side) securing the bottom corner of the grille to the vehicle.

**TOOLS REQUIRED**

10mm socket/spanner

**FASTENERS**

6x M10x35 hex bolt

Retain for Reassembly



- 25. Disconnect the camera wiring harness on top of the radiator.
- 26. Remove the grille and set aside in a safe place.

**TOOLS REQUIRED**

**FASTENERS**

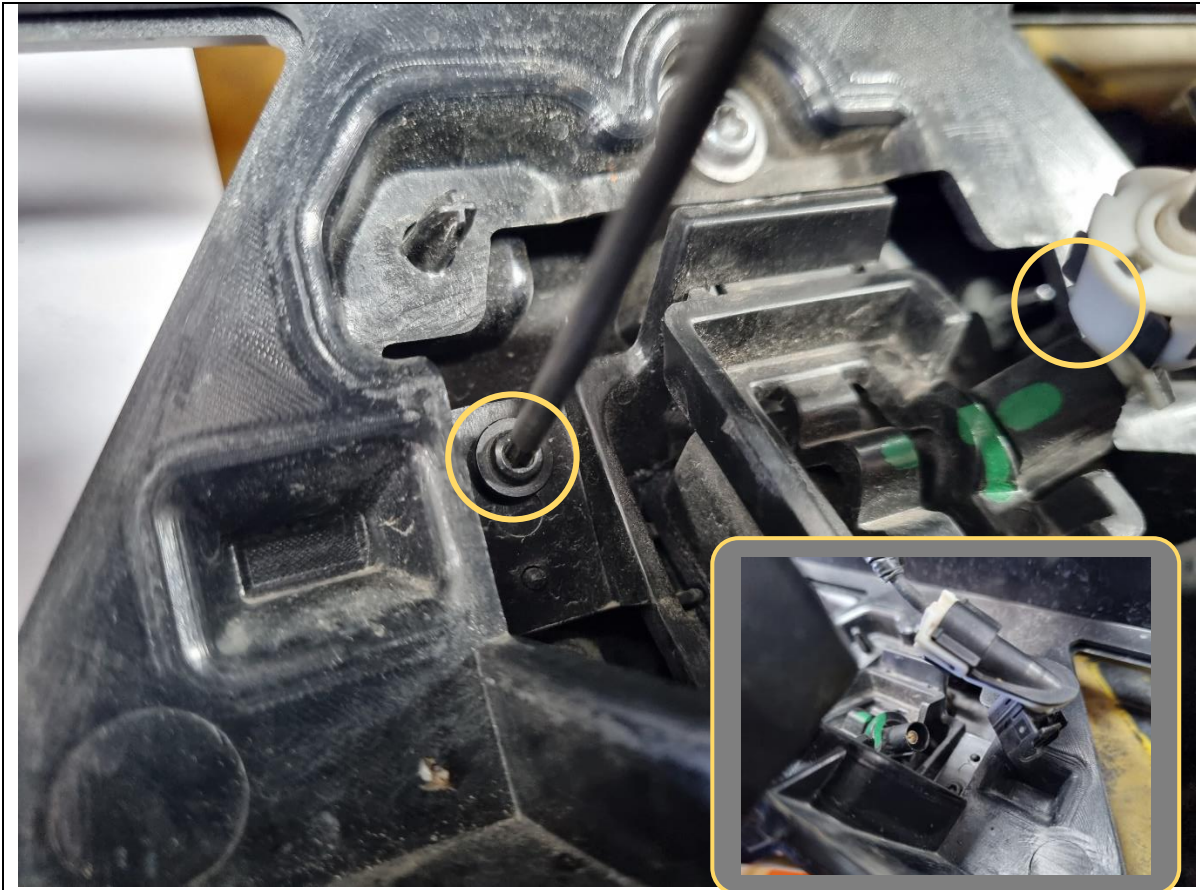

- 27. Locate the camera from behind the grille, underneath the 'A' of the RAM badge. Disconnect the wiring harness from the camera body.
- 28. Remove the camera and its housing from the grille, by removing 2x T10 Torx screws.

**TOOLS REQUIRED**

T10 Torx bit

**FASTENERS**

2x T10 Torx screws

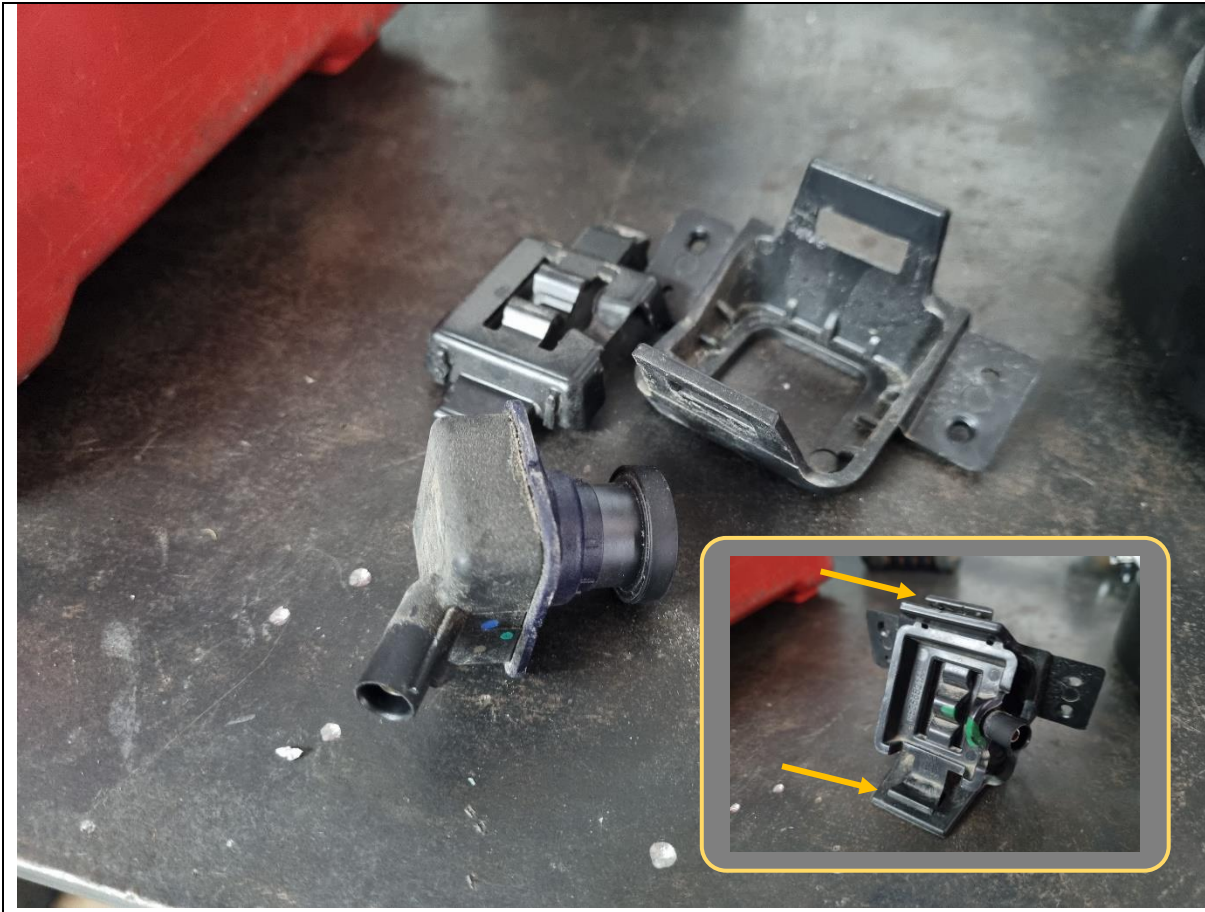

29. Unclip the camera from its plastic housing and set aside for later.

**TOOLS REQUIRED**

**FASTENERS**

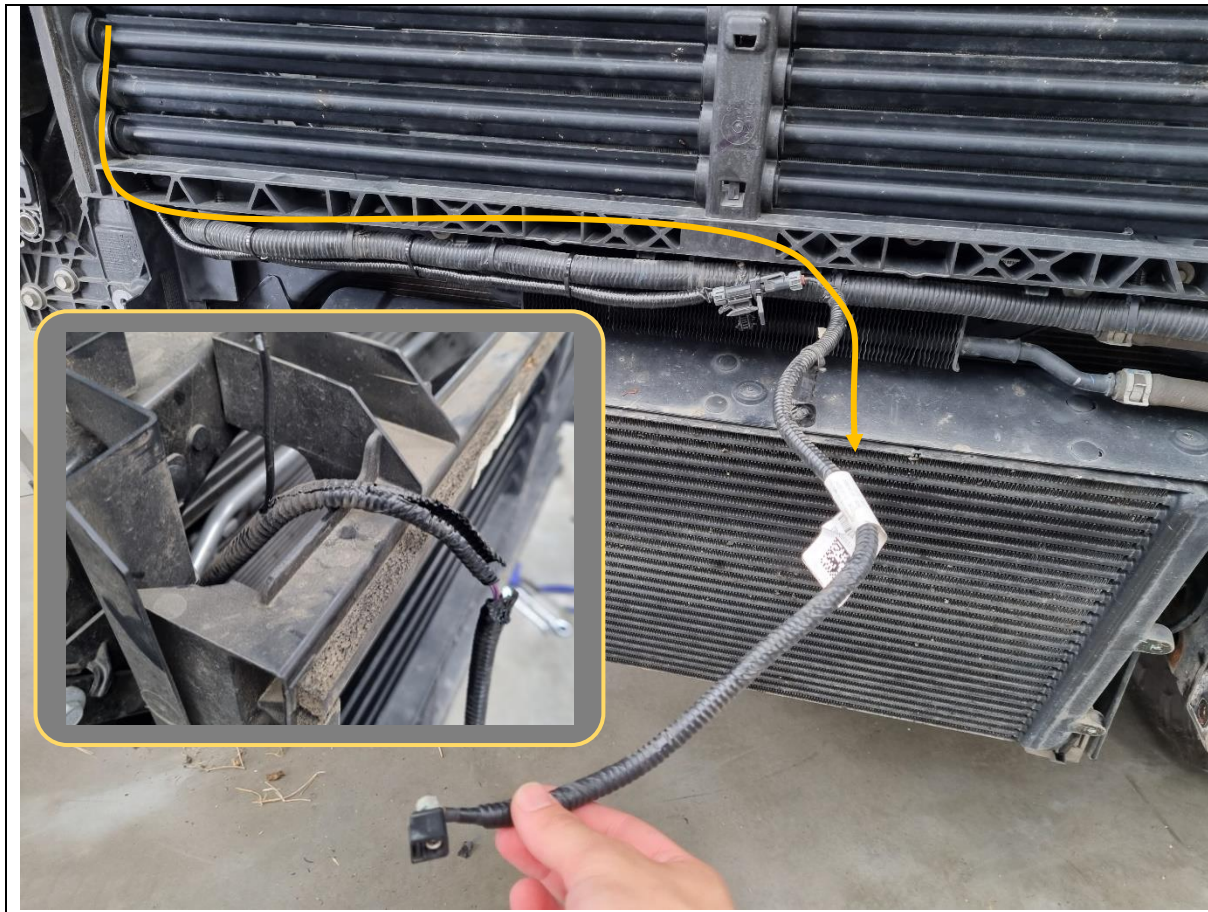

30. On the vehicle side, separate the camera wiring harness from the bonnet open sensor harness by cutting open the corrugated split tubing.

31. Split it all the way down until you reach the bottom corner of the radiator active shutters. Repair the cut open corrugated split tubing with electrical tape.

32. Route the camera wiring harness across to the centre of vehicle in between the radiator and intercooler.

**Do not route harness through the active shutters/louvres.**

33. Remove the wiring harness from the grille (unclip with trim tool or flat blade screwdriver) and connect to the vehicle harness.

**TOOLS REQUIRED**

**FASTENERS**



34. Refit the grille and trim pieces in reverse order.

**TOOLS REQUIRED**

**FASTENERS**

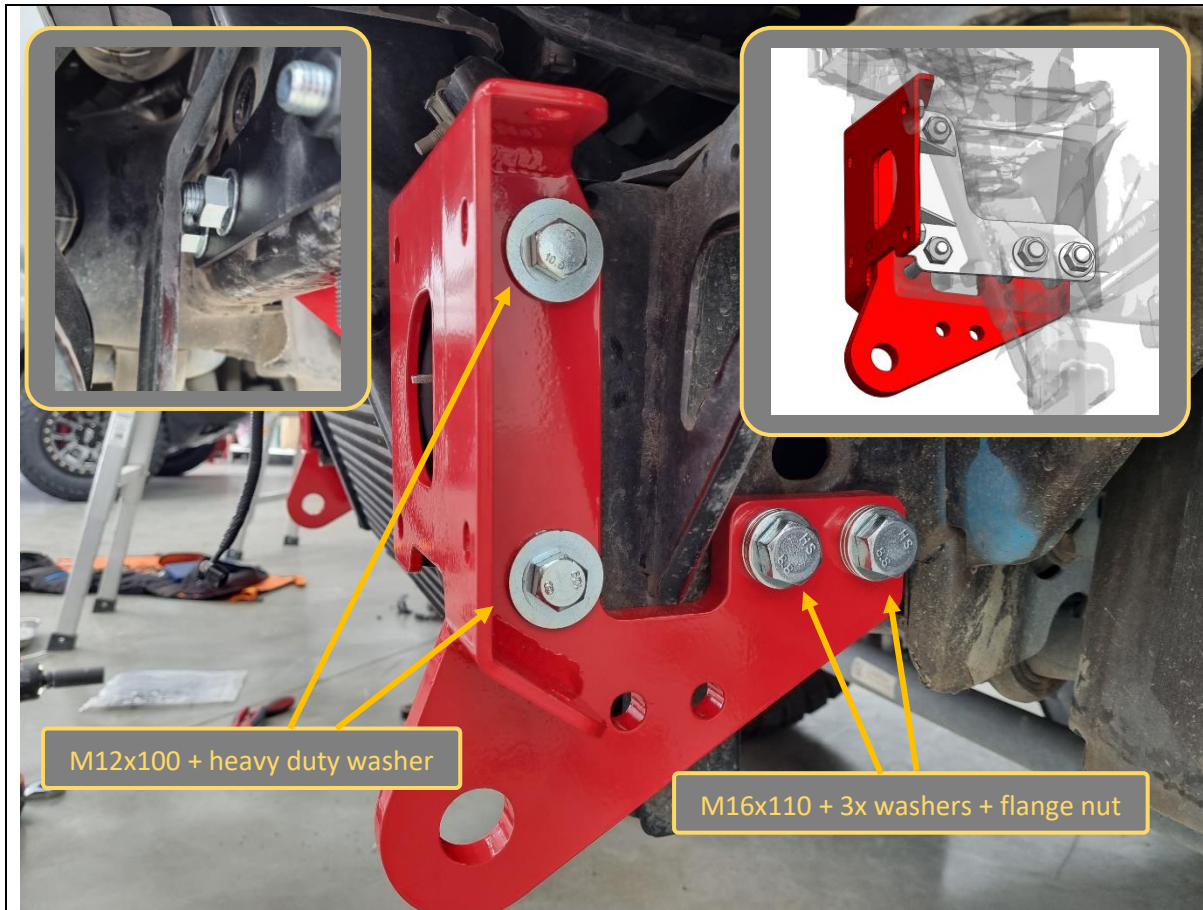

M12x100 + heavy duty washer

M16x110 + 3x washers + flange nut

- 35. Fit the tow point and chassis brace to the vehicle.
- 36. Secure from the side with 2x M12x100 hex bolts + washers for the front two holes, and 2x M16x110 + 3x stacked washers + flange nuts for the rear two holes.

The stacked washers are required to provide enough clearance between the M16 bolt and intercooler support bracket.

- 37. Tighten bolts and repeat for both sides.

**TOOLS REQUIRED**

- 19mm socket
- 24mm socket

**FASTENERS**

- 4x M12x100 hex bolt
- 4x M12 heavy duty washer
- 4x M16x110 hex bolt
- 12x M16 flat washer
- 4x M16 flange nut

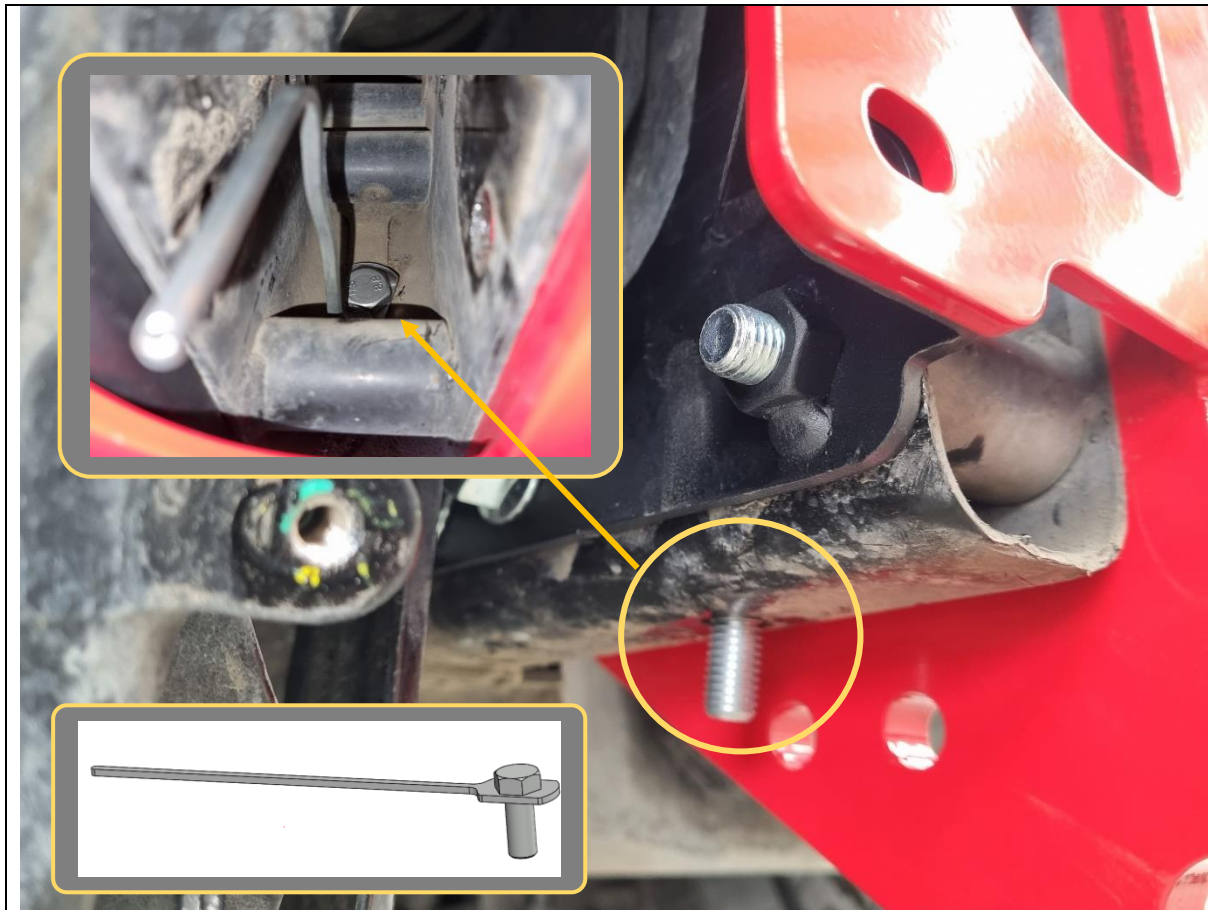

38. Install 1x M12 lollipop bolt plate through the bottom hole in the chassis rail, per side. Leave hanging for now.

The bolt plate can be inserted through the front opening of the chassis rail. Bend the lollipop stick to get it to reach.

**TOOLS REQUIRED**

**FASTENERS**

2x M12 lollipop bolt plate



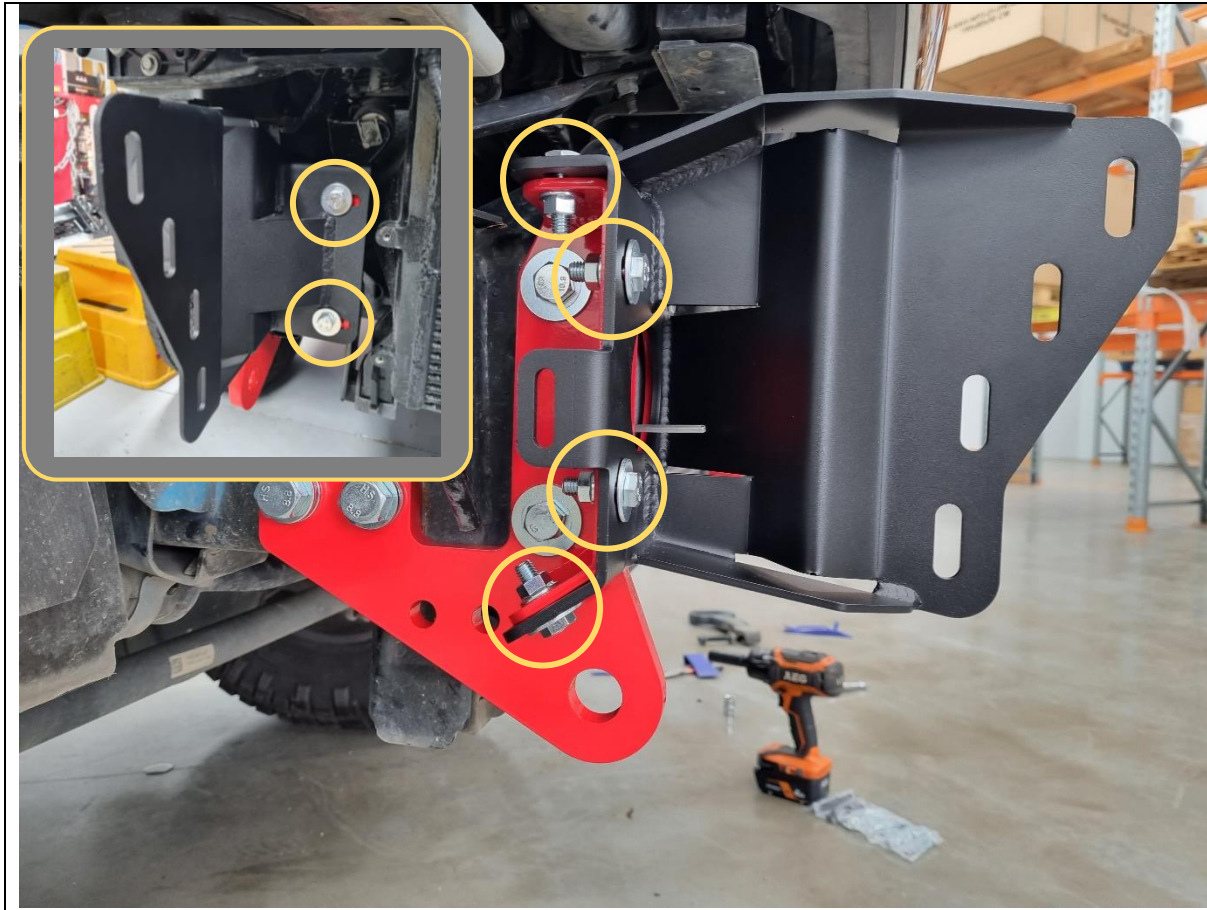

39. Loosely fit the impact assembly onto the vehicle, and secure to the tow point and chassis brace using 6x M10x30 hex bolts, 6x heavy duty washers and 4x flange nuts.

40. Leave bolts loose at this stage. Repeat for both sides.

**TOOLS REQUIRED**

**FASTENERS**

- 12x M10x30 hex bolt
- 12x M10 heavy duty washer
- 8x M10 flange nuts

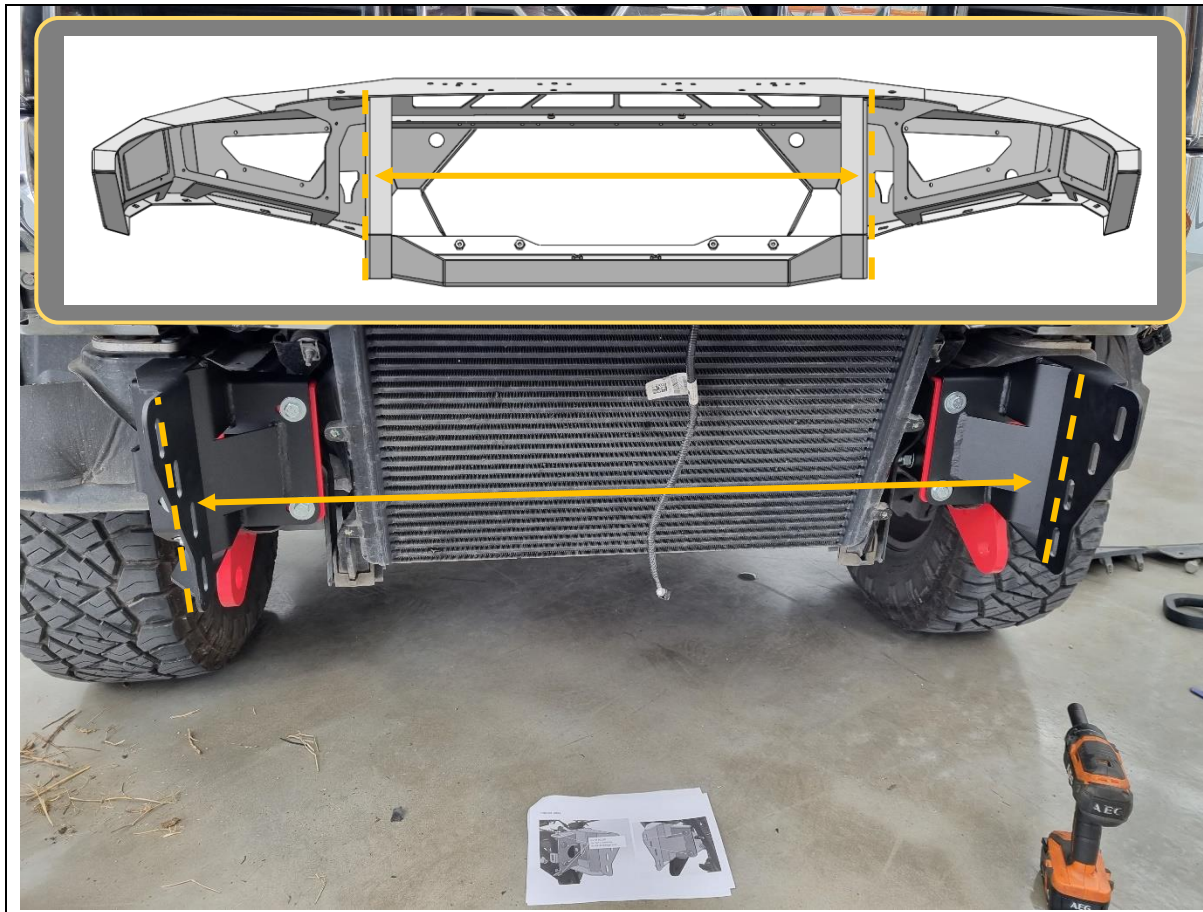

41. Measure the distance between the outside faces of uprights on bar using tape measure. Write distance below for reference if required.

Bar Upright Width = \_\_\_\_\_mm

42. Adjust mounts by sliding left/right on the slots, such that distance between inner faces of mounts are approximately 2mm more than bar. Ensure the mount faces are vertically upright and symmetric left/right on the chassis.

43. Secure and tighten mounts.

**TOOLS REQUIRED**

Tape measure

16mm socket/spanner

**FASTENERS**

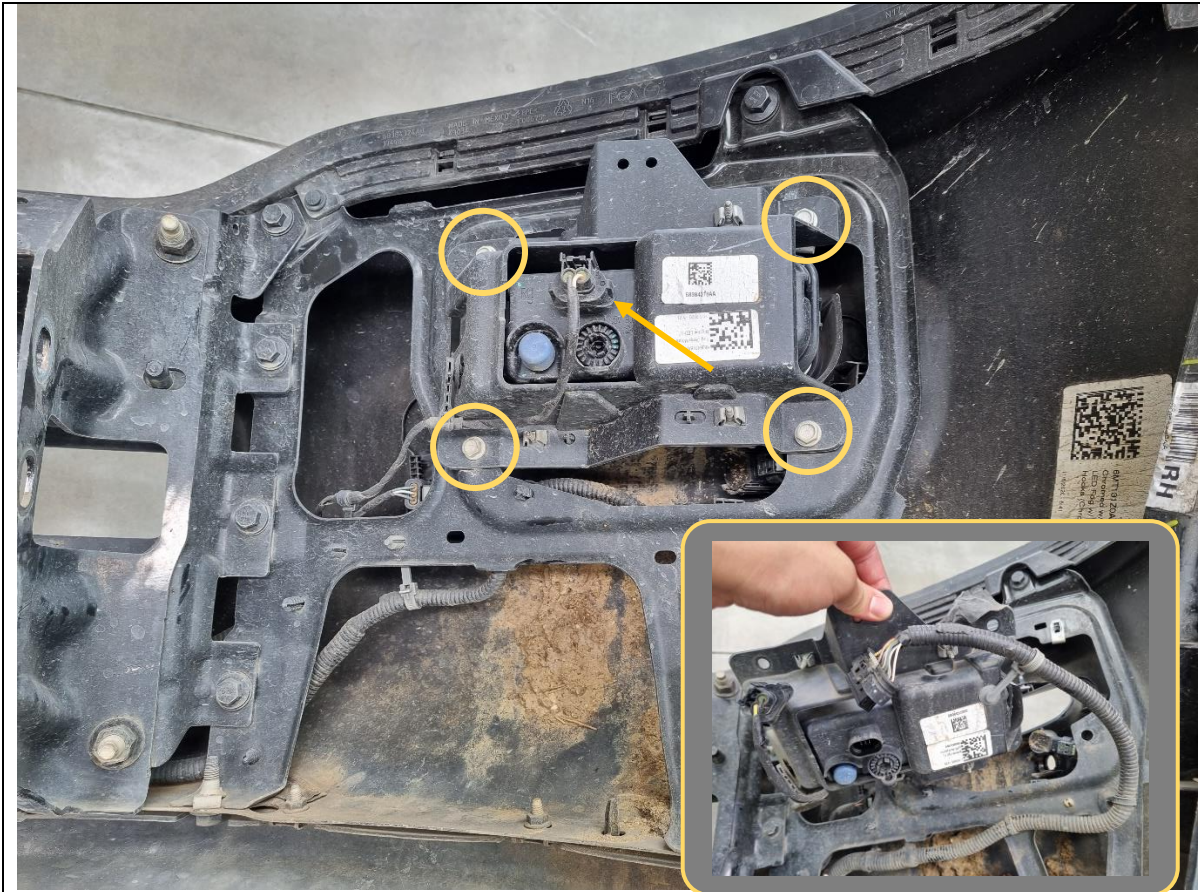

- 44. Prepare the bumper for stripping sensors and looms.
  - 45. Unplug both fog light connectors (see arrow).
  - 46. Loosen the fog lights from the bumper to reveal parking sensors, by removing 4x 10mm hex bolts for each fog light.
- Note down the orientation of the parking sensors before fully removing.

**TOOLS REQUIRED**

10mm socket/spanner

**FASTENERS**



47. Note down the orientation of each of the 6x parking sensors and their plastic holders, by looking at the direction the plug is pointing.
48. Carefully pry apart the sensor holder plastic tabs to unclip each parking sensor.
49. Squeeze on the tabs (see arrow) of each sensor holder and push them out the front of the bumper.

**TOOLS REQUIRED****FASTENERS**

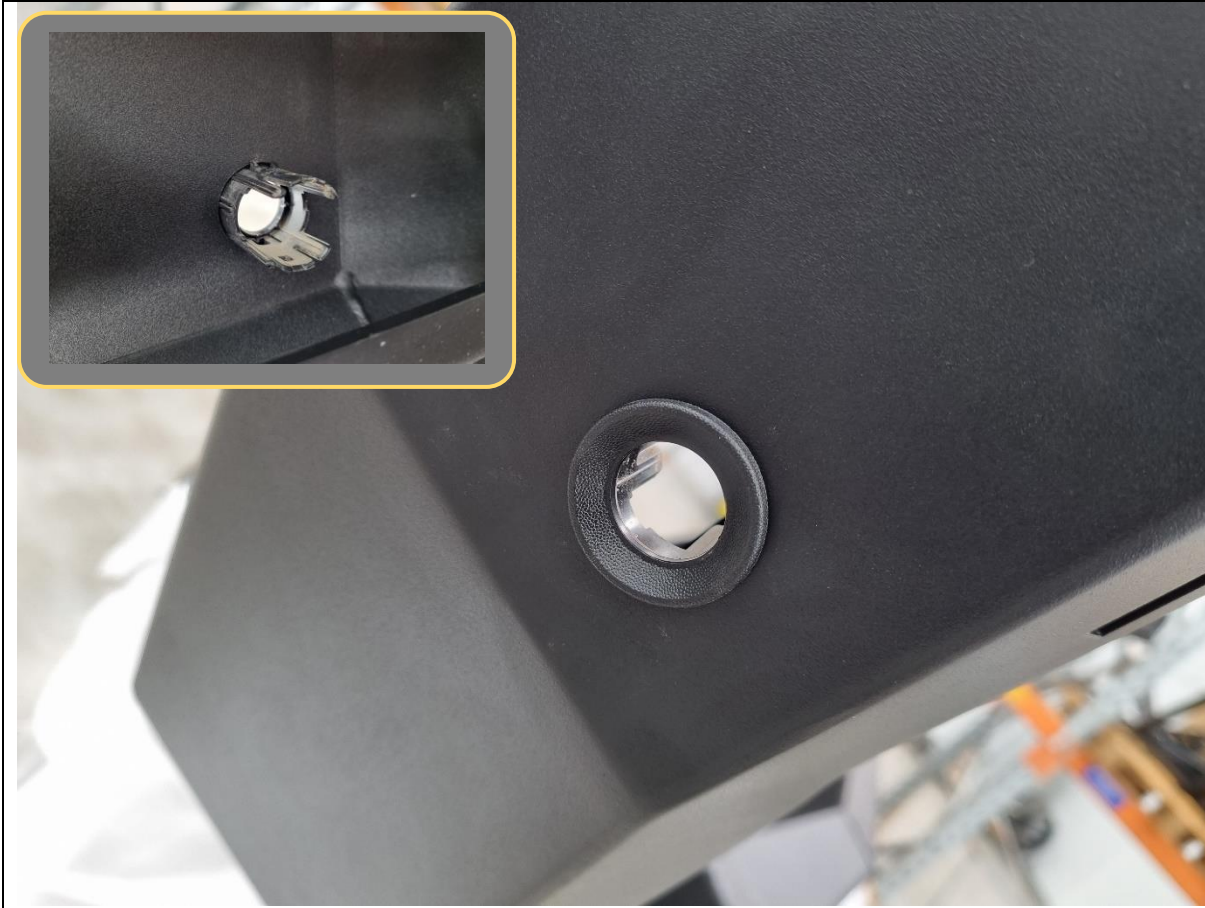

50. Clip the sensor holders into holes provided in the bulbar. Ensure their orientation matches the factory steel bumper.

**TOOLS REQUIRED**

**FASTENERS**



51. Strip the wiring harness and parking sensors from the stock bumper, then install and route through onto the bulbar.
52. Ensure the harness orientation matches the stock bumper.
53. Clip in parking sensors into the previously installed sensor holders.

**Note:** Ensure no part of the wiring harness sits directly behind any parking sensor. The electromagnetic field from the harness can cause false detections for the sensor.

**TOOLS REQUIRED**

**FASTENERS**



- 54. If the option has been selected, fit the Offroad Animal Halo fog lights to the supplied fog light brackets using 4x M4x12 pan head screws, flat washers and flange nuts (each).
- 55. Fit the fog light and bracket to the mesh panel, using the supplied 2x M8x12 hex bolts, flat washers and flange nuts.

**TOOLS REQUIRED**

- Phillips head screwdriver
- 13mm socket

**FASTENERS**

- 8x M4x12 pan head
- 8x M4 flat washer
- 8x M4 flange nut
- 4x M8x12 hex bolt
- 4x M8 flat washer
- 4x M8 flange nut



56. Fit the indicator repeater lamps to the indicator brackets, using M3 Phillips head Screws and the adhesive backing included with the lamp module.

**TOOLS REQUIRED**

Small Phillips screwdriver

**FASTENERS**

4x M3 Screw  
4xM3 Washers  
4xM3 Nuts





- 57. Insert the M6 Cage nut into the square hole in the top corner of the Fog Light Mesh panel.
- 58. Fit the indicator brackets to the mesh panel, using the supplied M6 Fasteners. The indicator should be located centrally in the cutout.

**TOOLS REQUIRED**

4mm hex/Allen Key

**FASTENERS**

4x M6x16 black button head  
4x M6 black washer  
4x M6 flange nut



59. Fit the fog light + mesh panel to the bulbar using 4x M16x16 black button head bolts, black flat washers and flange nuts.
60. Secure and tighten using 4mm hex/Allen key and repeat for other side.
61. Re-wire the fog light and connect to the bumper loom.
62. **Toro only.** Unplug the main headlight harness connector located on the back side of the headlight on both sides.
63. **Toro only.** Probe with a test light to determine indicator signal and ground.
64. **Toro only.** Splice and solder automotive electrical wires into the headlight harness for indicator signal and ground. Use heat shrink or electrical tape to insulate solder connections.
65. **Toro only.** Fit crimp terminals to the indicator lamp wiring in the bar, and matching terminals to the ends of spliced wire.

**TOOLS REQUIRED**

4mm hex/Allen key

**Toro only**

Cutting pliers  
Wire strippers  
Soldering iron  
Solder  
Automotive electrical wire  
Heat shrink  
Heat gun  
Electrical tape

**FASTENERS**

8x M6x16 black button head  
8x M6 black washer  
8x M6 flange nut

**Toro only**

4x Crimp Terminal pairs

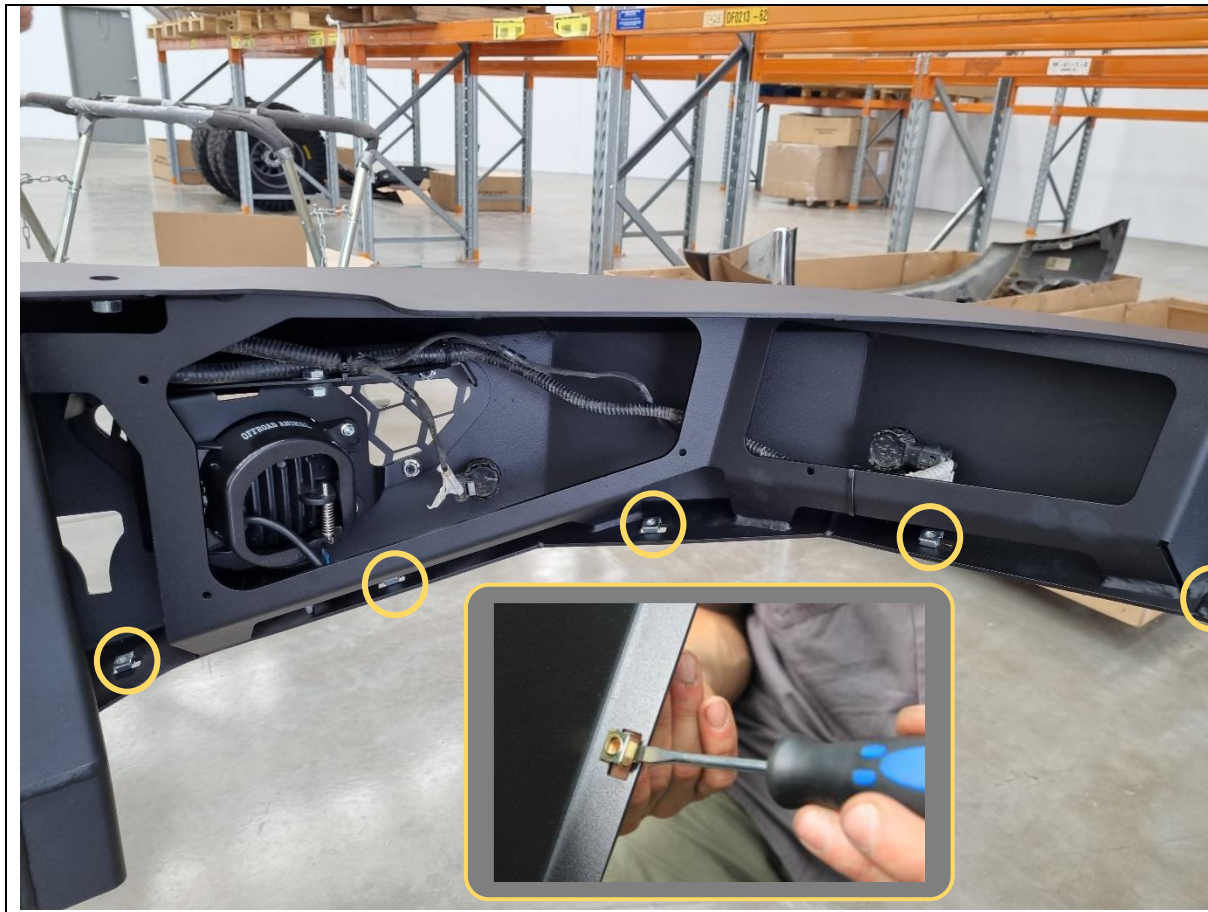

66. Fit 5x M6 cage nuts into the rectangular slots on the bottom of the bar wing.
- To aid fitting, use a small flat blade screwdriver to push the edge of the cage nut to engage with the slot.
67. Repeat for other side of the bar.

**TOOLS REQUIRED**

Flat blade screwdriver

**FASTENERS**

10x M6 cage nut



68. If fitting an integrated light bar, do so now.

This bar is designed to fit the Offroad Animal 32-inch light bar. If fitting this light bar, assemble the light bar with legs facing inwards, and line it up with the slots in the centre gusset. Secure with M6 fasteners supplied with the light.

This bar can accommodate most other “30-32inch” size light bars.

69. If fitting driving lights or top hoop to this bar, this is also the most convenient time to do so. It is still possible later but is more difficult.

70. Fit 2x pan braces to the back of the bar (see inset) using 10x M6x16 black button head bolts, flat washers and flange nuts.

71. Tidy up the wiring harness and other looms with cable ties on the inside of the bar.

**TOOLS REQUIRED**

- 4mm hex/Allen key
- 10mm spanner
- Supplied with light bar

**FASTENERS**

- 10x M6x16 black button head
- 10x M6 black flat washer
- 10x M6 flange nut
- Supplied with light bar



- 72. With assistance, either from another person, or a lifting trolley, lift the bar onto the mounts on the vehicle.
- 73. Reconnect the fog light and sensor loom to the vehicle. (For Toro, also connect the indicator repeater lamps)
- 74. Secure the bar to the mounts with 8x M12x30 Bolts, heavy duty washers and M12 Nyloc + flange nuts. Leave finger tight at this stage.

Note: Use a washer on both bolt and nut side for the Nyloc nut. 1x washer on the bolt side is all that is required with flange nuts.

**TOOLS REQUIRED**

Lifting trolley

**FASTENERS**

8x M12x30 hex bolt  
10x M12 heavy duty washer  
2x M12 Nyloc nut  
6x M12 flange nut

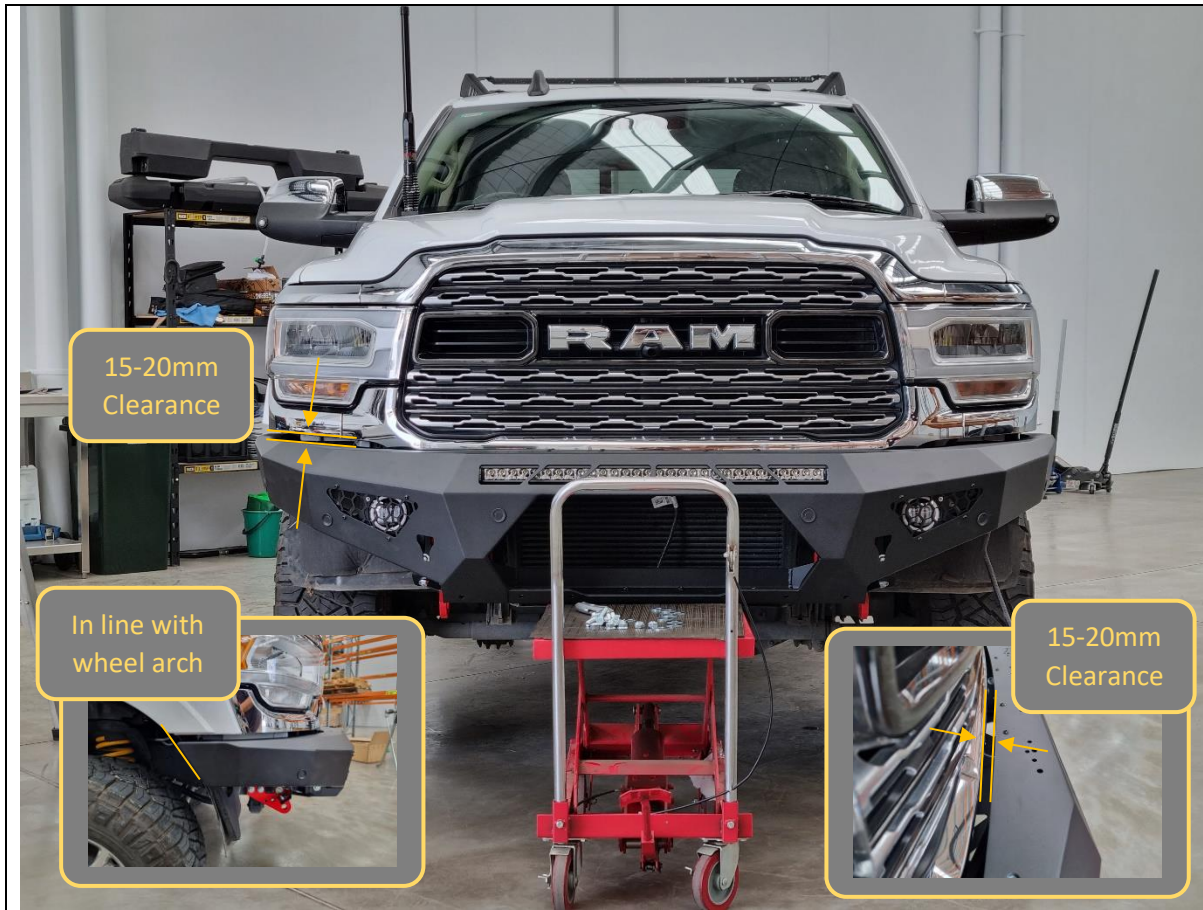

75. With assistance, from another person, align the bar with the edges of the vehicle. The bar should sit symmetric left/right on the vehicle.

In front view, the top face of the bar should sit parallel with the bottom edge of the chrome headlight trim, with about 15-20mm vertical clearance.

In side view, the end of the bar wing should be in line with the wheel arch liner.

In top view, there should be 15-20mm clearance between the bar and grille.

76. Once happy with alignment, tighten all 8x M12 bolts.

**TOOLS REQUIRED**

18/19mm socket/spanner

**FASTENERS**



- 77. If fitting a winch, do so now.
- 78. This bar is designed to fit most low mount winches, in foot down configuration. WARN ZEON 12 is the largest winch confirmed to fit.
- 79. Ensure clutch handle will be accessible through opening in front mesh panel. Refer to winch instructions regarding changing clutch handle location.

**TOOLS REQUIRED**

Refer to instructions supplied by winch

**FASTENERS**

Supplied with winch



80. Install the tension strap connecting the bottom of the winch cradle to the previously installed M12 bolt plates, using 4x M18x20 hex bolts and heavy duty washers, and 2x M12 flange nuts.

**TOOLS REQUIRED**

13mm socket  
18/19mm socket

**FASTENERS**

4x M8x20 hex bolt  
4x M8 heavy duty washer  
  
2x M12 flange nut





- 81. If required, fit the winch fairlead to the mesh fairlead mount using M10 or 3/8" fasteners supplied with the winch. This bar is only compatible with hawse type fairleads.
- 82. Fit number plate flip mount to mesh panel using 2x M6x20 hex bolts, flat washers and flange nuts supplied in the number plate flip kit.
- 83. Attach number plate to mount using supplied pan head screws in the number plate flip kit.

**TOOLS REQUIRED**

- 10mm socket
- 13mm socket/spanner
- 4mm hex/Allen key
- Phillips head screwdriver

**FASTENERS**

- 2x M6x20 hex bolt
- 2x M6 flat washer
- 2x M6 flange nut

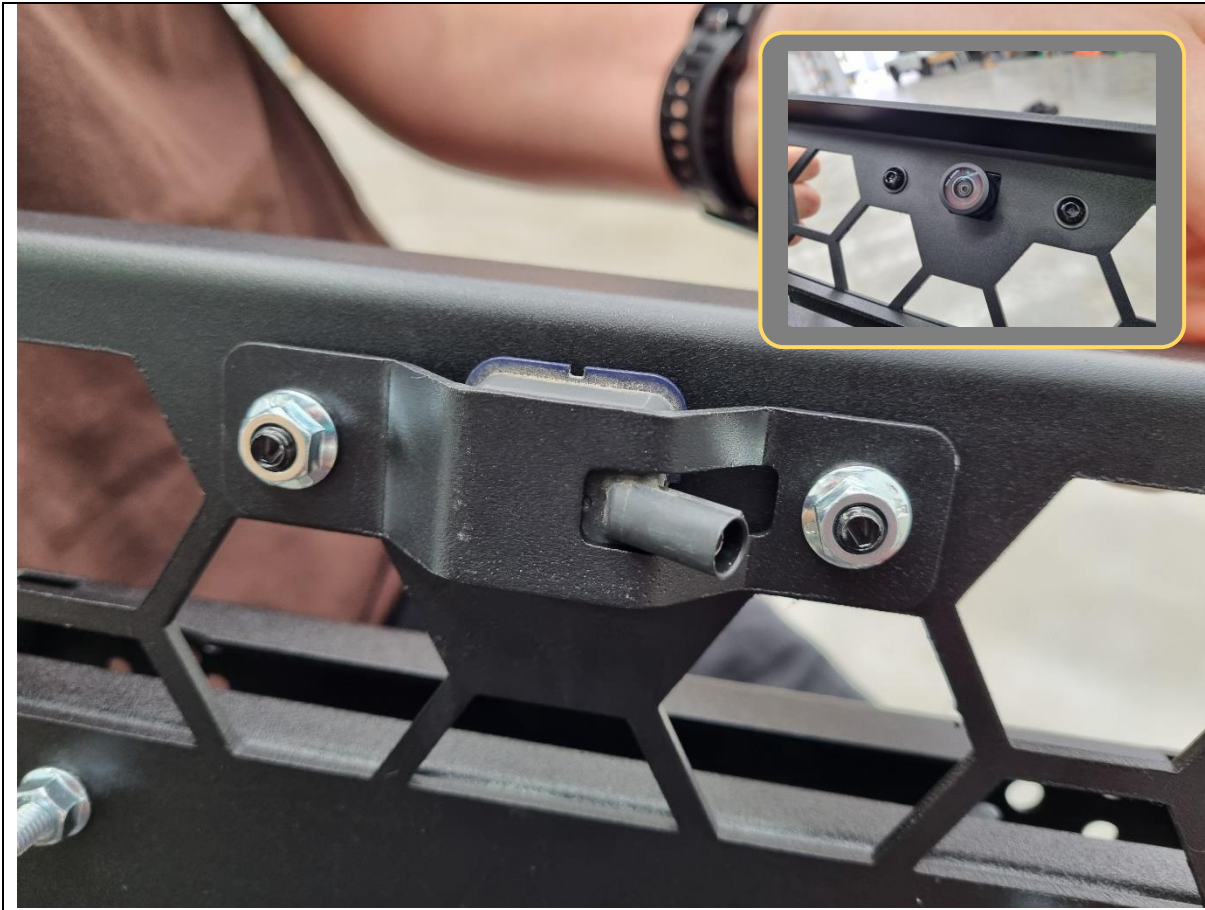

84. If relocating the front camera, sandwich/clamp the camera between the mesh fairlead mount and camera relocation bracket and secure using 2x M16x16 black button head bolts, black flat washers and flange nuts.

Ensure the camera orientation matches the image shown (also confirm with orientation of camera in stock grille).

**TOOLS REQUIRED**

4mm hex/Allen key

**FASTENERS**

2x M6x16 black button head  
2x M6 black flat washer  
2x M6 flange nut

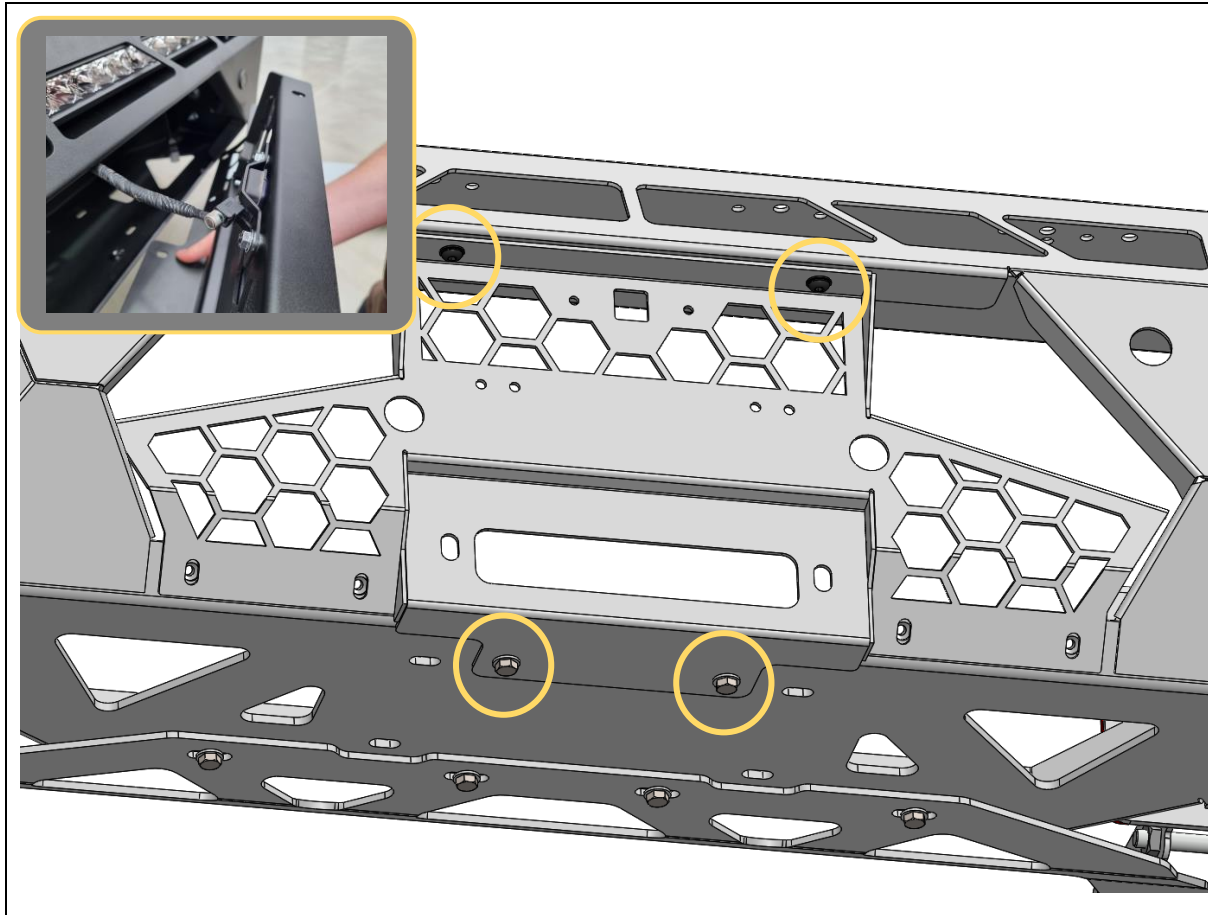

- 85. If applicable, hold the mesh fairlead mount up near the bar and reconnect the camera harness to the back of the camera in the mount.
- 86. Fit the mesh fairlead mount to the centre of the bar, using 2x M8x16 black button head bolts (top), 2x M8x20 hex head bolts (bottom) and 4x flat washers.
- 87. Tighten fasteners using 13mm socket/spanner and 5mm hex/Allen key.
- 88. Feed winch cable through the hawse fairlead if applicable.

**TOOLS REQUIRED**

13mm socket/spanner  
5mm hex/Allen key

**FASTENERS**

2x M8x16 black button head  
2x M8 black flat washer

2x M8x20 hex head  
2x M8 flat washer

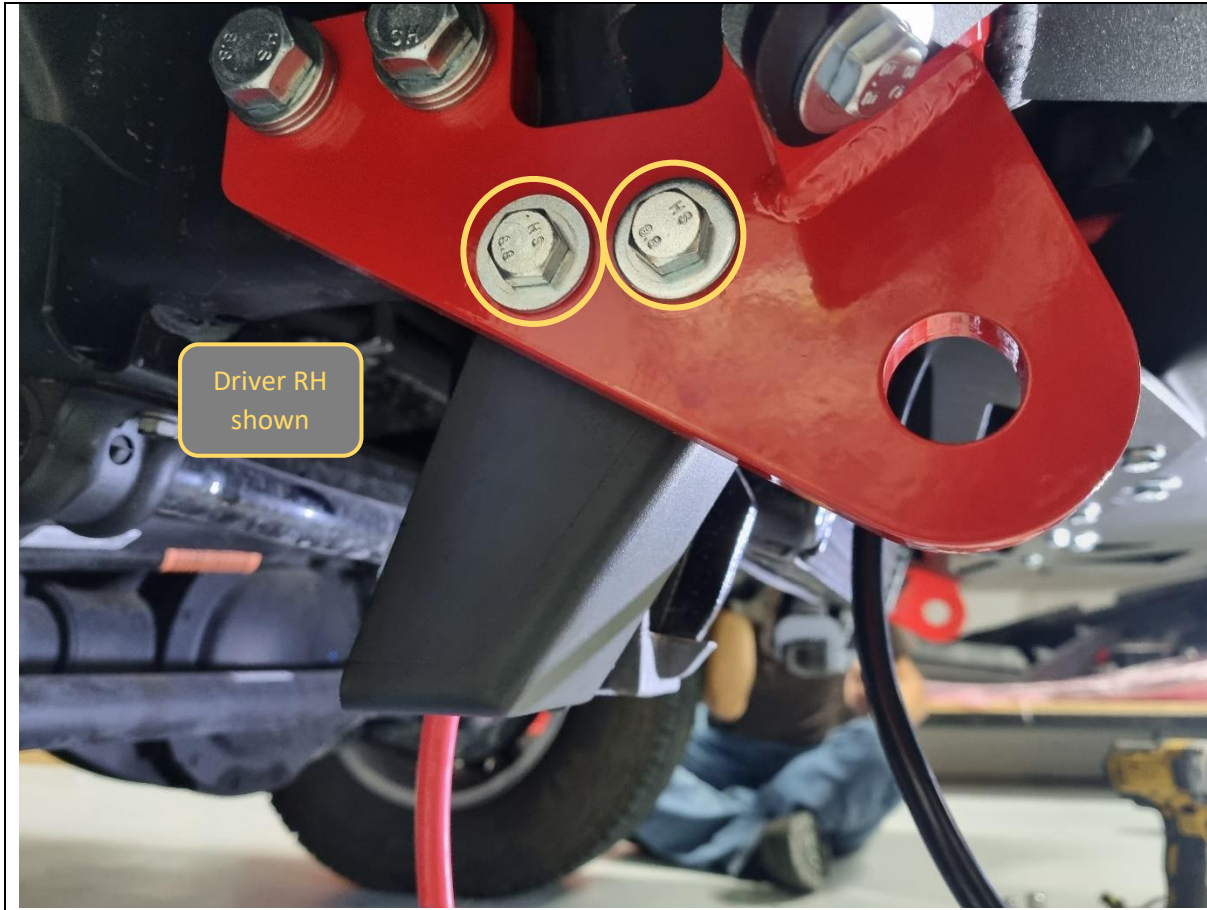

89. Fit the bash plate mounts to the tow points and secure with 2x M10x40mm hex bolts, flat washers and flange nuts (each).

**TOOLS REQUIRED**

16mm socket/spanner

**FASTENERS**

4x M10x40 hex head bolt  
4x M10 heavy duty washer  
4x M10 flange nut



- 90. Fit the centre bash plate to the bar using 6x M8x25 black button bolts and flat washers.
- 91. Secure the back of the centre bash plate to the bash plate mounts using 2x M10x25 button head bolts, flat washers and flange nuts.

**TOOLS REQUIRED**

- 5mm hex/Allen key
- 6mm hex/Allen key

**FASTENERS**

- 6x M8x25 black button head
- 6x M8 black flat washer
- 2x M10x25 button head bolt
- 2x M10 flat washer
- 2x M10 flange nut

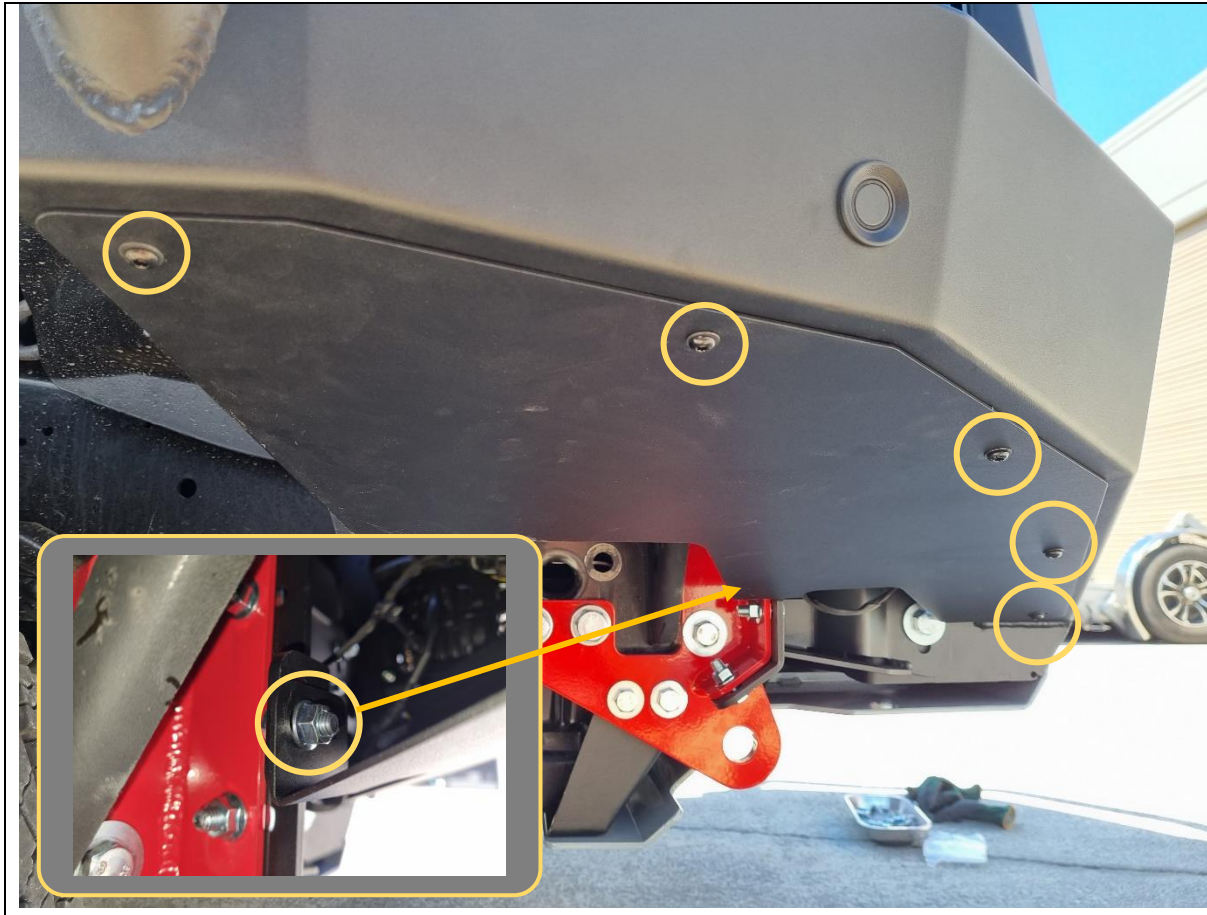

- 92. Loosely secure the side underpanel to the bar with 5x M6x16 black button head bolts and black flat washers.
- 93. Loosely secure the side underpanel to the impact assembly using 1x M8x20 hex head bolt, flat washer and flange nut.
- 94. Repeat for other side underpanel.

**TOOLS REQUIRED**

- 4mm hex/Allen key
- 13mm socket/spanner

**FASTENERS**

- 10x M6x16 black button head
- 10x M6 black flat washer
- 2x M8x20 hex head bolt
- 2x M8 flat washer
- 2x M8 flange nut

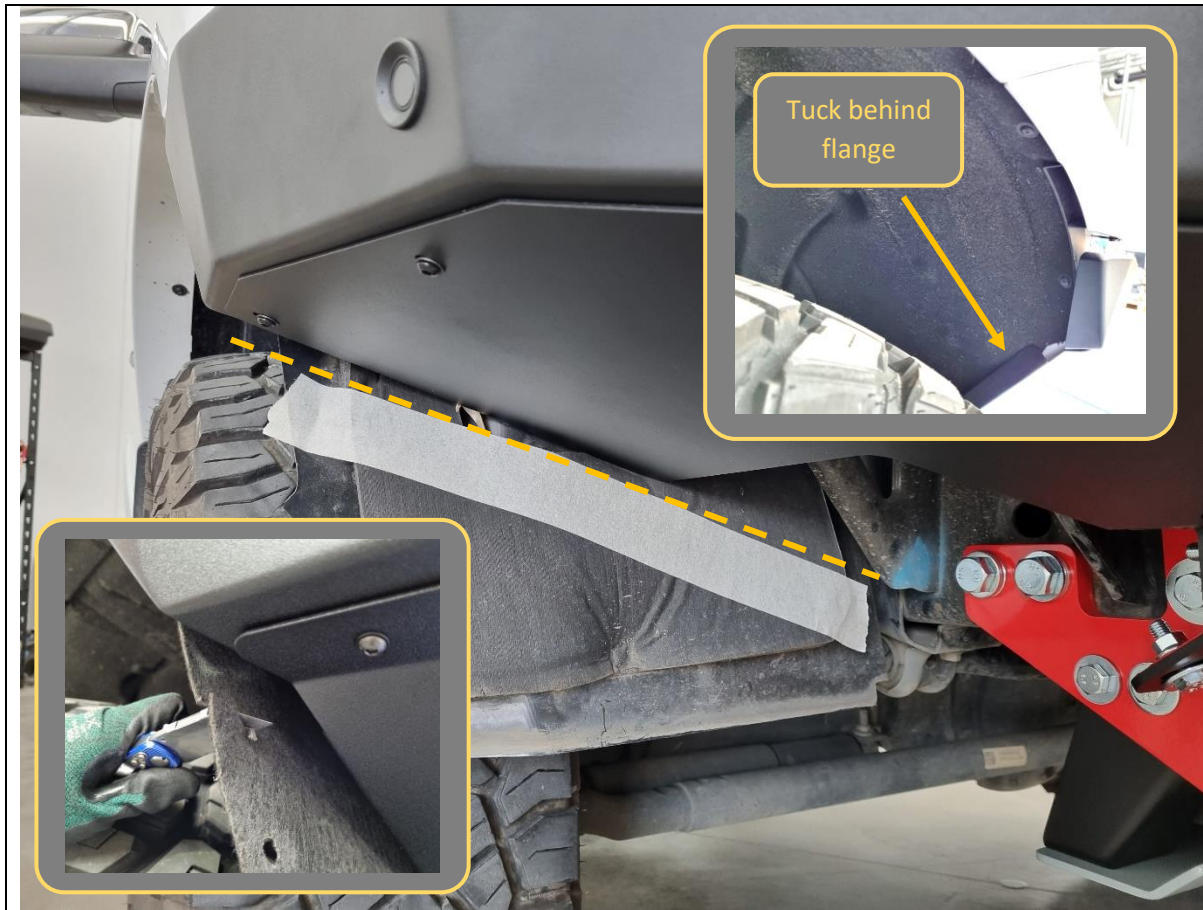

95. Using the edge of the side underpanel as a guide, mark the wheel arch liner, approximately 10mm below the side underpanel.

96. Cut along the marked line with a utility knife.

97. Tuck the wheel arch liner behind the flange of the side underpanel.

98. Tighten all side underpanel bolts and repeat for other side.

**TOOLS REQUIRED**

Utility knife

4mm hex/Allen key

13mm socket/spanner

**FASTENERS**



- 99. Fit the Offroad Animal logo plate to the front of the vehicle as shown.
- 100. Fit the compliance plate in a visible location on the underside of the bar. We recommend placing it on the bottom of the centre bash plate.
- 101. If fitting antennas or other accessories on the Toro bar, fit the antenna mount bracket to the back of the Toro uprights using 2x M8x20 black button head bolts and black flat washers.
- 102. Review fitment and double check all bolts are tightened correctly.

**TOOLS REQUIRED**

5mm hex/Allen key

**FASTENERS**

M8x20 black button head  
M8 flat washer





**Congratulations! You're done!**  
**Head out of town and enjoy your newly protected RAM 2500/3500!**