



## TOYOTA LANDCRUISER PRADO 250

MY2025+

## PREDATOR & TORO FRONT BAR

### **IMPORTANT! – READ BEFORE INSTALLATION**

- When installed in accordance with these instructions, the front protection bar does not affect the operation of the vehicle's SRS airbags.
- This product must be installed exactly as per these instructions using only hardware supplied.
- Take a few moments to read instructions thoroughly before beginning work.
- In the event of damage to any bar component please contact OFFROAD ANIMAL to arrange repair/replacement of components.
- Do not use this product for any vehicle make or model other than that specified on these instructions.
- Do not remove labels from this product.
- This product and its fixings must not be modified in any way unless stated in these fitting instructions.
- The installation of this product is recommended for trained personnel.
- These instructions are correct at time of publication. OFFROAD ANIMAL cannot be held responsible for the impact of any changes subsequently made by the vehicle manufacturer. If you find something has changed please contact us to let us know!
- During installation it is the duty of the installer to check correct operation/clearances of all components.
- If Instructions are to be printed for reference in the workshop, it is recommended that they are printed in colour, for best legibility.



# PARTS LISTING

**IMPORTANT:** Check all parts are present before beginning work! Contact OFFROAD ANIMAL if something is missing.

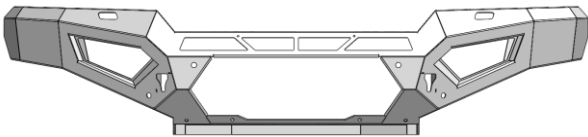
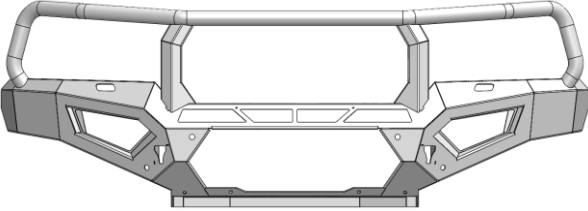
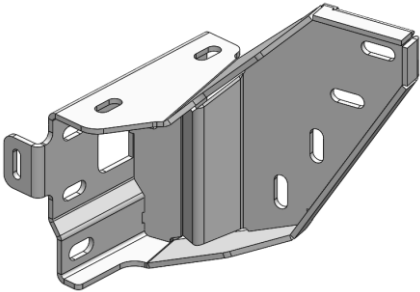
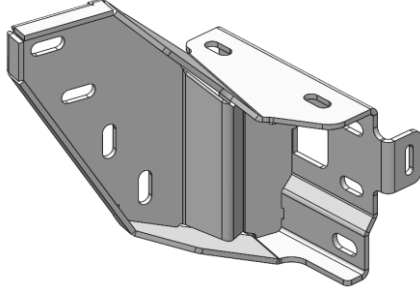
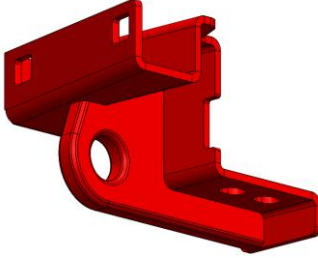

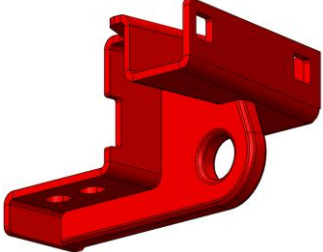
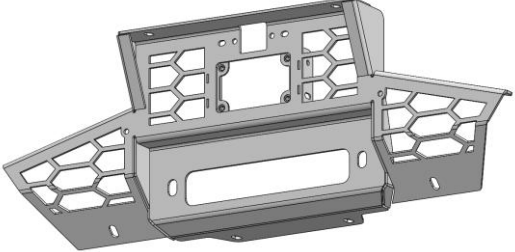
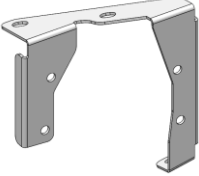
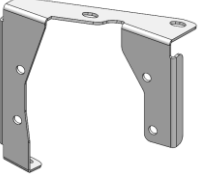
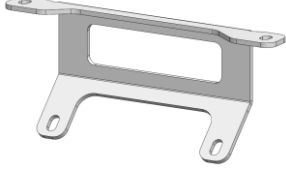
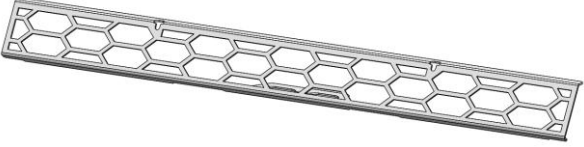
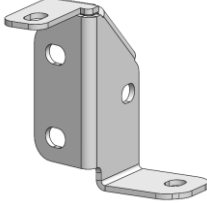
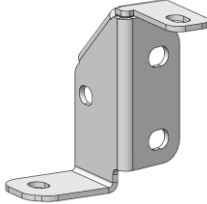

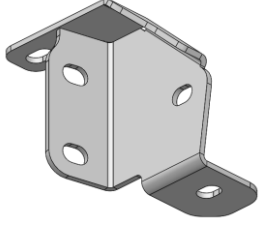
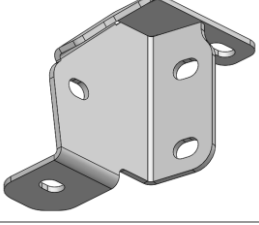
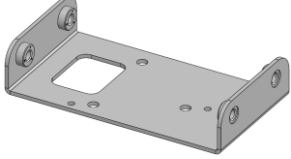
## Main Parts – In the Box

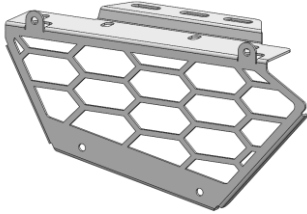
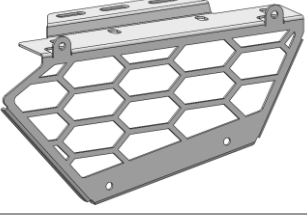
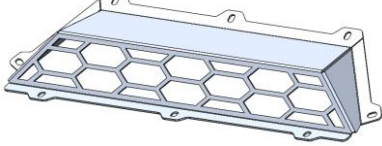
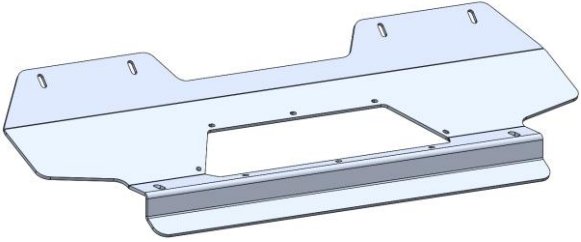

Qty	Part Number	Description	Image
1	FB-TPR-250-25-PR-ASM1	Prado 250 MY25+ Predator Bar Weldment	
<b>OR</b>			
1	FB-TPR-250-25-TOR-ASM1	Prado 250 MY25+ Toro Bar Weldment	
1	FB-TPR-250-25-PR-ASM2R	Prado 250 MY25+ Impact Assembly RH	
1	FB-TPR-250-25-PR-ASM2L	Prado 250 MY25+ Impact Assembly LH	
1	FB-TPR-250-25-PR-ASM3R	Prado 250 Tow Point Welded Assembly RH	

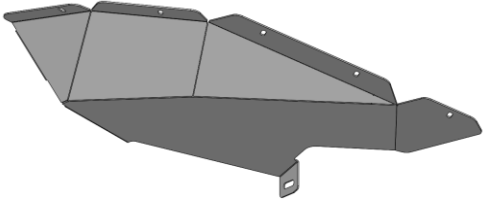
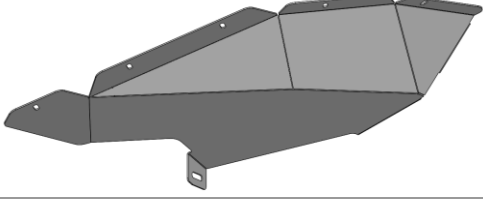

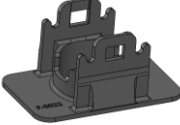
<p><b>1</b></p>	<p>FB-TPR-250-25-PR-ASM3L</p>	<p>Prado 250 Tow Point Welded Assembly LH</p>	
<p><b>1</b></p>	<p>FB-TPR-250-25-PR-ASM4</p>	<p>Prado 250 MY25+ Mesh Fairlead Welded Assembly</p>	
<p><b>1</b></p>	<p>B-1431R</p>	<p>Prado 250 Fog Light Bracket RH</p>	
<p><b>1</b></p>	<p>B-1431L</p>	<p>Prado 250 Fog Light Bracket LH</p>	
<p><b>2</b></p>	<p>B-1433</p>	<p>Prado 250 Pan Brace</p>	
<p><b>1</b></p>	<p>B-1434</p>	<p>32" Lightbar Mesh Infill</p>	
<p><b>1</b></p>	<p>B-1442R</p>	<p>Prado 250 Outer Chassis Support RH</p>	
<p><b>1</b></p>	<p>B-1442L</p>	<p>Prado 250 Outer Chassis Support LH</p>	

1	B-1443R	Prado 250 Inner Chassis Support LH	
1	B-1443L	Prado 250 Inner Chassis Support RH	
1	B-1447	Prado 250 ACC Radar Mount	
1	B-1465R	Prado 250 Headlight Washer Retainer RH	
1	B-1465L	Prado 250 Headlight Washer Retainer LH	
1	M-0058R	Prado 250 Wing Light Mesh RH	
1	M-0058L	Prado 250 Wing Light Mesh LH	
1	M-0060	Prado 250 Bash Plate Cooling Mesh	
1	U-0095	Prado 250 Bash Plate	

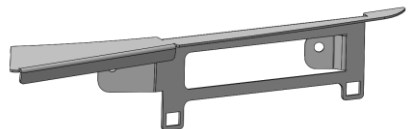

1	U-0096R	Prado 250 Side Underpanel RH	
1	U-0096L	Prado 250 Side Underpanel LH	
1	OFA-LOGO	Offroad Animal Metal Logo	
1	FB-TPR-250-25-PR-ADRCP	ADR Compliance Plate Prado 250 Series	
4	F-0022	LC300 Sahara ZX + GR Sport Sensor Holder	
1	N-0017	Prado 250 ACC Radar Cover	
2	PWS-TOP-850	Pinch Weld PWS51T - Top Bulb Seal 850mm	N/A
1	TK-COM-PSEN-4	Tape Kit - 4 Sensor Universal	N/A
1	TK-FB-TPR-250-25	Tape Kit - Prado 250 MY25+, 3M5952 (4x 80x6mm, 4x 40x30mm, 6x 100x9mm), 2x 3M Primer 94	N/A
2	UC-14-3-90MM	U CHANNEL RUBBER 90MM LONG, AMBASSADOR PART NUMBER 7 R32-50/U277	N/A

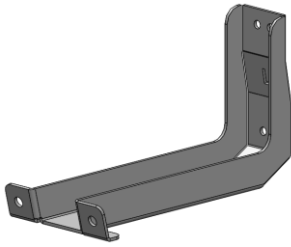
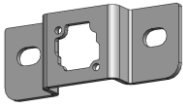
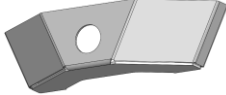
<b>NUMBER PLATE FLIP ASSEMBLY (NPF-COM-LGE-ASM0)</b>			
<b>1</b>	B-1446	Number Plate Flip - Large	
<b>1</b>	B-1458	Number Plate Flip Base	
<b>GX/GXL/ALTITUDE ONLY (FB-TPR-250-25-PR-ASM5)</b>			
<b>1</b>	B-1432	Prado 250 Grille Infill - Offroad Spec	
<b>1</b>	B-1449	Prado 250 Camera Bracket - Offroad Spec	
<b>1</b>	B-1450	Prado 250 Camera Housing - Offroad Spec	
<b>1</b>	B-1452	Prado 250 Grille Support - Offroad Spec	
<b>1</b>	B-1468R	Prado 250 Headlight Infill Mount - Offroad Spec RH	
<b>1</b>	B-1468L	Prado 250 Headlight Infill Mount - Offroad Spec LH	
<b>1</b>	F-0034R	Prado 250 Headlight Infill - Offroad Spec RH	
<b>1</b>	F-0034L	Prado 250 Headlight Infill - Offroad Spec LH	

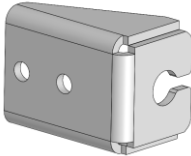
<b>VX/KAKADU ONLY (FB-TPR-250-25-PR-ASM6)</b>			
<b>1</b>	B-1469	Prado 250 Grille Support - Luxury Spec	
<b>1</b>	B-1470	Prado 250 Camera Bracket - Luxury Spec	
<b>1</b>	B-1471	Prado 250 Camera Housing - Luxury Spec	
<b>1</b>	CPHP125	Plastic Hole Insert, 16MM, Black, Tigerlink Hardware CPHP125	
<b>TORO ONLY</b>			
<b>2</b>	B-0649	Toro Antenna Bracket - 90 Degree Tall	

**PREDATOR Fasteners – Contained in Small Parts Kit Bag**

Qty	Part Number	Description
5	M6x12 BHCS BLACK ZINC	SCREW, BUTTON HEAD CAP, M6X12X1 GR12.9, ISO4042 ZnNi BLACK PASSIVATED FINISH
52	M6x16 BHCS BLACK ZINC	SCREW, BUTTON HEAD CAP, M6X16X1 GR12.9, ISO4042 ZnNi BLACK PASSIVATED FINISH
57	M6 FLAT WASHER BLACK ZINC	M6 Flat Washer, 12x6.1x1, ISO4042 ZnNi BLACK PASSIVATED FINISH
27	M6 FLANGE NUT	Flange Nut, M6x1 G8.8 ZP
10	M6CN3MM	CAGE NUT M6x2.6-3.5
10	M8 X 16 BHCS BZP	SCREW, BUTTON HEAD CAP, M8X16X1.25 GR12.9, ISO4042 ZnNi BLACK PASSIVATED FINISH
6	M8 X 30 BHCS BLACK ZINC	SCREW, BUTTON HEAD CAP, M8X30X1.25, ISO4042 ZnNi BLACK PASSIVATED FINISH
2	M8 X 20 HEX	Bolt Hex, M8X20x1.25, GR8.8 ZP
16	M8 FLAT WASHER- BLACK ZINC	M8 FLAT WASHER, 16.5x8.4x1.2, ISO4042 ZnNi BLACK PASSIVATED FINISH
2	M8 HD FLAT WASHER	M8 FLAT WASHER - High Tensile 19x8x1.9mm
10	M8 FLANGE NUT	Flange Nut, M8x1.25 G8.8 ZP
2	M10X25 BHCS	SCREW, BUTTON HEAD CAP, M10X25X1.5 GR12.9 ZP
2	M10 FLAT WASHER	M10 Flat Washer
2	M10 FLANGE NUT	Flange Nut, M10x1.5 G8.8 ZP
24	M12X30	Bolt Hex, M12X30x1.75, GR8.8 ZP
2	M12X40	Bolt Hex, M12X40X1.75, GR8.8 ZP
6	M12 FLAT WASHER	M12 Flat Washer
22	M12 FW LHD	M12 FW Large Heavy Duty
18	M12 FLANGE NUT	Flange Nut, M12x1.75 G8.8 ZP
2	M12 NYLOC NUT	M12 Nyloc nut
6	NP-COM-M12-30-ASM0	M12 NUT PLATE SHORT, 30MM STEM

**TORO Fasteners – Contained in Small Parts Kit Bag**

Qty	Part Number	Description
5	M6x12 BHCS BLACK ZINC	SCREW, BUTTON HEAD CAP, M6X12X1 GR12.9, ISO4042 ZnNi BLACK PASSIVATED FINISH
52	M6x16 BHCS BLACK ZINC	SCREW, BUTTON HEAD CAP, M6X16X1 GR12.9, ISO4042 ZnNi BLACK PASSIVATED FINISH
57	M6 FLAT WASHER BLACK ZINC	M6 Flat Washer, 12x6.1x1, ISO4042 ZnNi BLACK PASSIVATED FINISH
27	M6 FLANGE NUT	Flange Nut, M6x1 G8.8 ZP
10	M6CN3MM	CAGE NUT M6x2.6-3.5
10	M8 X 16 BHCS BZP	SCREW, BUTTON HEAD CAP, M8X16X1.25 GR12.9, ISO4042 ZnNi BLACK PASSIVATED FINISH
4	M8 X 20 BHCS BLACK ZINC	SCREW, BUTTON HEAD CAP, M8X20X1.25, ISO4042 ZnNi BLACK PASSIVATED FINISH
6	M8 X 30 BHCS BLACK ZINC	SCREW, BUTTON HEAD CAP, M8X30X1.25, ISO4042 ZnNi BLACK PASSIVATED FINISH
2	M8 X 20 HEX	Bolt Hex, M8X20x1.25, GR8.8 ZP
20	M8 FLAT WASHER- BLACK ZINC	M8 FLAT WASHER, 16.5x8.4x1.2, ISO4042 ZnNi BLACK PASSIVATED FINISH
2	M8 HD FLAT WASHER	M8 FLAT WASHER - High Tensile 19x8x1.9mm
10	M8 FLANGE NUT	Flange Nut, M8x1.25 G8.8 ZP
2	M10X25 BHCS	SCREW, BUTTON HEAD CAP, M10X25X1.5 GR12.9 ZP
2	M10 FLAT WASHER	M10 Flat Washer
2	M10 FLANGE NUT	Flange Nut, M10x1.5 G8.8 ZP
24	M12X30	Bolt Hex, M12X30x1.75, GR8.8 ZP
2	M12X40	Bolt Hex, M12X40x1.75, GR8.8 ZP
6	M12 FLAT WASHER	M12 Flat Washer
22	M12 FW LHD	M12 FW Large Heavy Duty
18	M12 FLANGE NUT	Flange Nut, M12x1.75 G8.8 ZP
2	M12 NYLOC NUT	M12 Nyloc nut
6	NP-COM-M12-30-ASM0	M12 NUT PLATE SHORT, 30MM STEM

**NUMBER PLATE FLIP Fasteners – Contained in Number Plate Flip Kit**

Qty	Part Number	Description
4	M6x12 BHCS BLACK ZINC	SCREW, BUTTON HEAD CAP, M6X12X1 GR12.9, ISO4042 ZnNi BLACK PASSIVATED FINISH
4	M6x16 BHCS BLACK ZINC	SCREW, BUTTON HEAD CAP, M6X16X1 GR12.9, ISO4042 ZnNi BLACK PASSIVATED FINISH
10	M6 FLAT WASHER BLACK ZINC	M6 Flat Washer, 12x6.1x1, ISO4042 ZnNi BLACK PASSIVATED FINISH
6	M6 FLANGE NUT	Flange Nut, M6x1 G8.8 ZP
2	M6 NYLON WASHER	Nylon Flat Washer, M6x12x1mm
2	M6 NYLOC	NYLOC SELF LOCKING NUT, ST STL A2 ISO

**GX/GXL/ALTITUDE ONLY Fasteners – Contained in ASM5 Kit**

Qty	Part Number	Description
16	M6x16 BHCS BLACK ZINC	SCREW, BUTTON HEAD CAP, M6X16X1 GR12.9, ISO4042 ZnNi BLACK PASSIVATED FINISH
16	M6 FLAT WASHER BLACK ZINC	M6 Flat Washer, 12x6.1x1, ISO4042 ZnNi BLACK PASSIVATED FINISH
6	M6 FLANGE NUT	Flange Nut, M6x1 G8.8 ZP
4	M6CN2MM	CAGE NUT M6x1.6-2.5

**VX/KAKADU ONLY Fasteners – Contained in ASM6 Kit**

Qty	Part Number	Description
6	M6x16 BHCS BLACK ZINC	SCREW, BUTTON HEAD CAP, M6X16X1 GR12.9, ISO4042 ZnNi BLACK PASSIVATED FINISH
6	M6 FLAT WASHER BLACK ZINC	M6 Flat Washer, 12x6.1x1, ISO4042 ZnNi BLACK PASSIVATED FINISH
4	M6 FLANGE NUT	Flange Nut, M6x1 G8.8 ZP

## TOOLS REQUIRED

The following tools will be required to install the product.

<b>Hand Tools</b>	<b>Power Tools</b>	<b>Workshop Equipment</b>
Metric Socket Set 10-19mm	Electric/Air Impact Driver (Optional)	Panel Stand or Soft Blanket
Socket Extension Bar	Air Hacksaw or Jigsaw or Multi-tool	Lifting Trolley
Metric Spanner Set 10-19mm	Angle Grinder	Isopropyl Alcohol
Hex (Allen) Key Set 4-6mm	Heat Gun	Brake Cleaner
T6 Torx bit		Rag
Trim Removal Tool		Cable Ties
Plastic Auto Trim Tool Set		Marker Pen
Flat Blade Screwdriver Set		Ruler
Phillips Head Screwdriver Set		Measuring Tape
Utility Knife		Masking Tape
Side Cutters		Sikaflex Adhesive
Hose Line Clamp		Bucket
Deburring Tool		Black spray paint
		Sandpaper (optional)
		Spray Paint (colour matched to bull bar) (optional)
		Digital angle gauge

# WORKSHOP SAFETY

It is the responsibility of the installer to always complete works in a safe manner. Make sure the following safety equipment is available and precautions are observed whilst fitting this product.

<p>Hearing Protection</p> 	<p>Always wear ear protection when using power tools.</p>
<p>Eye Protection</p> 	<p>Ensure eye protection is always worn when cutting or drilling.</p>
<p>Manual Handling</p> 	<p>Do not attempt to lift bar assemblies or rock sliders on your own.</p> <p>Always use two people to lift or use mechanical lifting aid such as hydraulic lifting trolley.</p>
<p>Vehicle Support</p> 	<p>Always ensure vehicle is properly supported when working on it. Do not attempt to fit products whilst suspension work is being carried out. Do not work under a vehicle supported only by a jack.</p>





<p><b>WARNING:</b> Do not attempt to turn on and move the vehicle while the front radar, camera and parking sensors are disconnected. Doing so may cause DTC error codes that can only be rectified by the dealer.</p> <p>1. Remove 2x screws holding front number plate with a Phillips head screwdriver and set aside.</p>	<p><b>TOOLS REQUIRED</b></p> <p>Phillips head screwdriver</p>
	<p><b>FASTENERS</b></p> <p>2x screws (discard)</p>

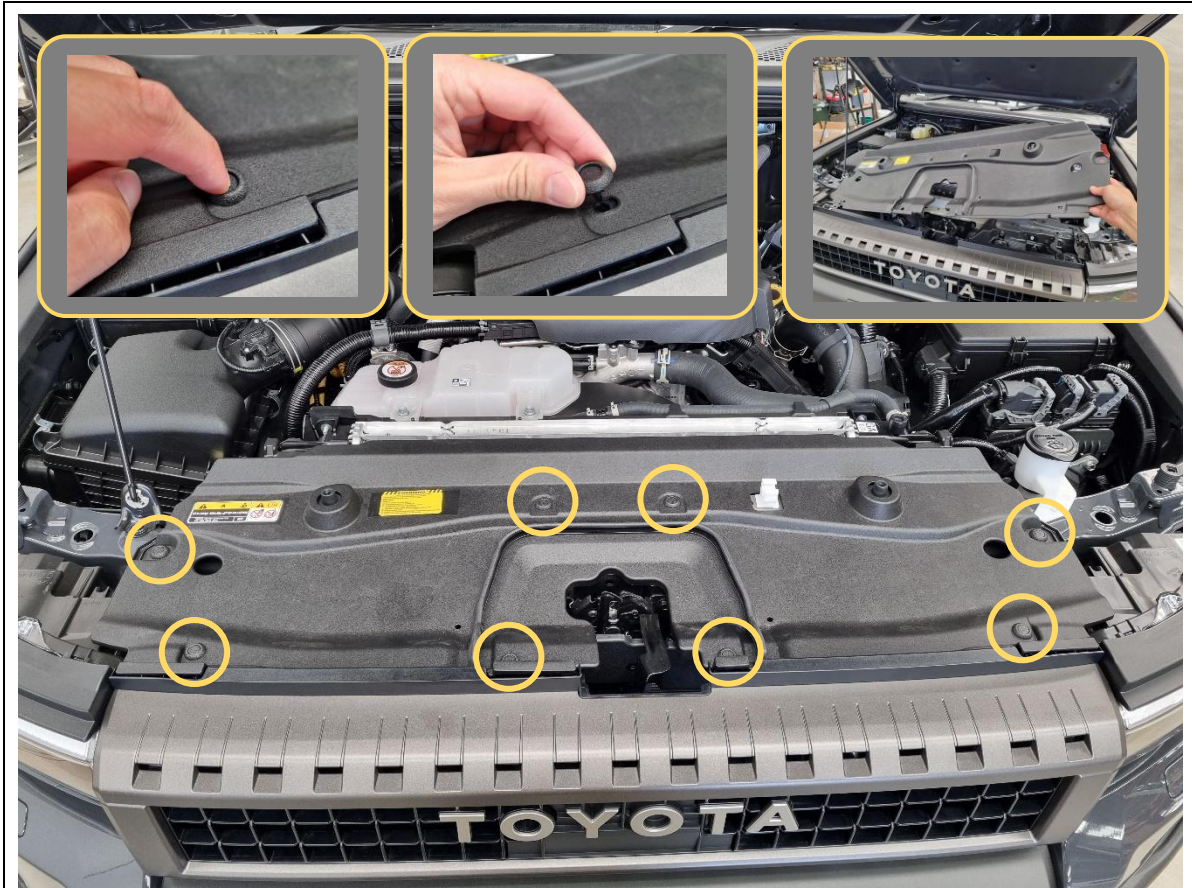

2. Open the bonnet.
3. Remove 8x plastic push clips holding the radiator top cover. Set cover and clips aside for re-assembly.  
  
Press down on the middle of the clip to remove.

**TOOLS REQUIRED**

**FASTENERS**

8x plastic push clips  
Retain for re-assembly



<p>4. Remove 3x 10mm hex bolts on holding the underside of the lower outer bumper spoiler.</p> <p>5. Remove 3x plastic push clips holding the rear of the lower outer bumper spoiler, in the wheel well.</p> <p>Use a flat blade screwdriver or trim tool to lever the centre section of the plastic clip outwards to remove.</p>	<p><b>TOOLS REQUIRED</b></p> <p>10mm socket Socket extension bar</p> <p>Flat blade screwdriver or Trim tool</p>
<p>6. Remove and discard the spoilers, for both sides.</p>	<p><b>FASTENERS</b></p> <p>6x 10mm hex bolts 6x plastic push clips</p> <p>Discard</p>





- Remove 2x 10mm hex bolts and 1x plastic push clip in the centre holding the bottom bumper cover on the underside of the bumper.

**TOOLS REQUIRED**

10mm socket/spanner  
Flat blade screwdriver  
or  
Trim tool

**FASTENERS**

1x 10mm hex bolt  
2x plastic push clips  
  
Discard



8. The front flares and mudflap need to be removed. Start by removing 3x 10mm hex screws and 1x plastic push clip holding each front wheel mudflap.

**TOOLS REQUIRED**

10mm socket/spanner  
Flat blade screwdriver  
or  
Trim tool

**FASTENERS**

6x 10mm hex screws  
2x plastic push clips  
Retain for re-assembly



<p>9. Remove 5x plastic push clips and 1x 10mm hex screw holding each front flare.</p>	<p><b>TOOLS REQUIRED</b></p> <p>10mm socket/spanner</p> <p>Flat blade screwdriver or Trim tool</p>
	<p><b>FASTENERS</b></p> <p>2x 10mm hex screws 10x plastic push clips</p> <p>Retain for re-assembly</p>





10. Starting from each end, pull the flare outwards and release the 14x body clips holding it to the body. Set the flares aside in a safe place for later.

**TOOLS REQUIRED**

**FASTENERS**



11. **VX/Kakadu only.** Vehicles with the 'luxury' spec grille will need the under headlight trim removed at this stage.

Starting from the end indicated by the arrow, pull outwards by hand to unclip the trim. Do this on for both headlight trims. Do not discard, and set aside in a safe place for later.

**TOOLS REQUIRED**

**FASTENERS**





12. Remove 3x 10mm hex bolts holding the top of the grille.

**TOOLS REQUIRED**

10mm socket/spanner

**FASTENERS**

3x 10mm hex bolts

Retain for re-assembly



13. Remove 6x 10mm hex bolts (3x per side) holding the bottom of the bumper.

**TOOLS REQUIRED**

10mm socket/spanner

**FASTENERS**

6x 10mm hex bolts



14. Remove 1x 10mm hex bolt and 1x plastic push clip on the outer end of the bumper. Do this on both sides.

**TOOLS REQUIRED**

10mm socket/spanner

Flat blade screwdriver  
or  
Trim tool

**FASTENERS**

2x 10mm hex bolts  
2x plastic push clips



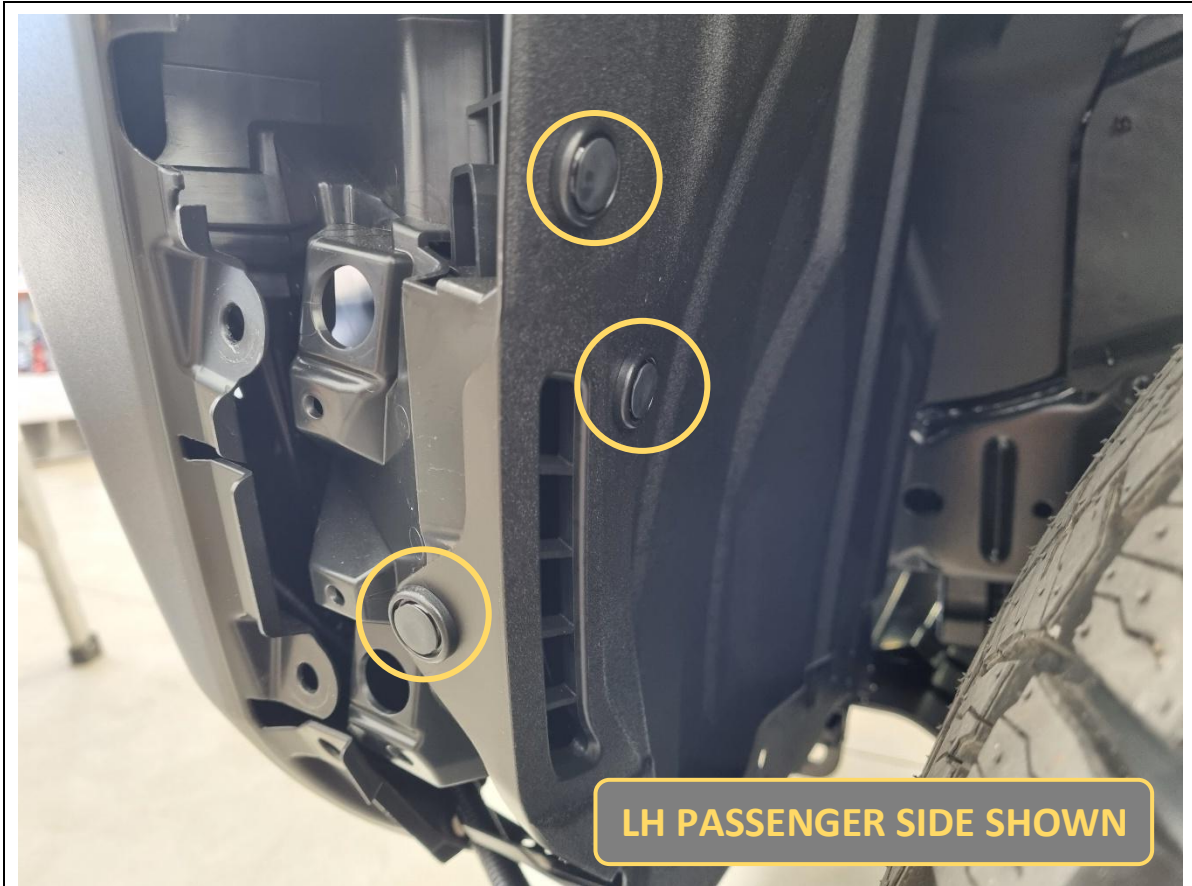

15. Remove 3x plastic push clips holding the front of the inner wheel guard. Do this on both sides.

**TOOLS REQUIRED**

Flat blade screwdriver  
or  
Trim tool

**FASTENERS**

6x plastic push clips



<p>16. Grab onto each outer end of the bumper and pull outwards to unclip the outer section only. Do not unclip the rest of the bumper yet.</p>	<p><b>TOOLS REQUIRED</b></p>
	<p><b>FASTENERS</b></p>

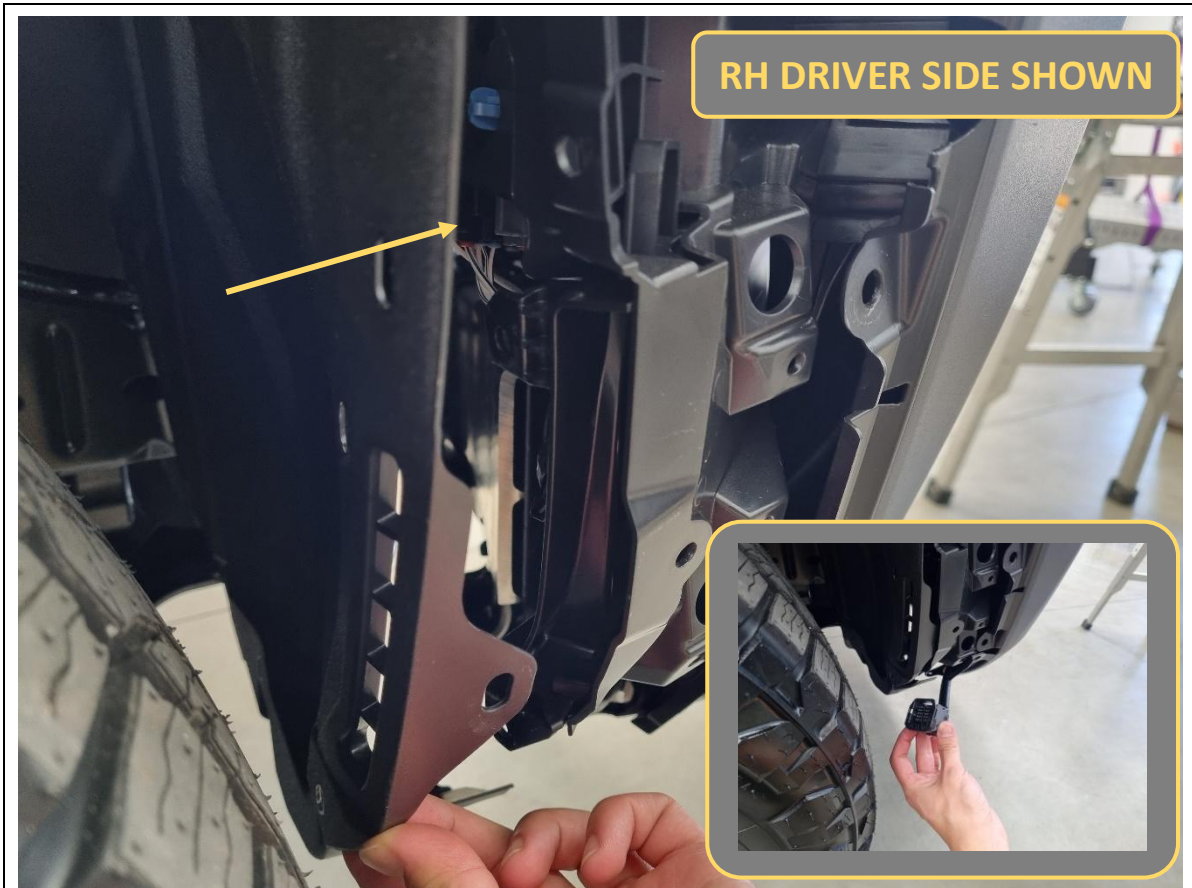

17. On the driver side, pull back on the inner wheel guard to gain access inside, then disconnect 1x bumper harness connector.

The connector is a lever lock style, you may need to use a flat blade screwdriver to assist in unlatching the lever.

**TOOLS REQUIRED**

Flat blade screwdriver (optional)

**FASTENERS**

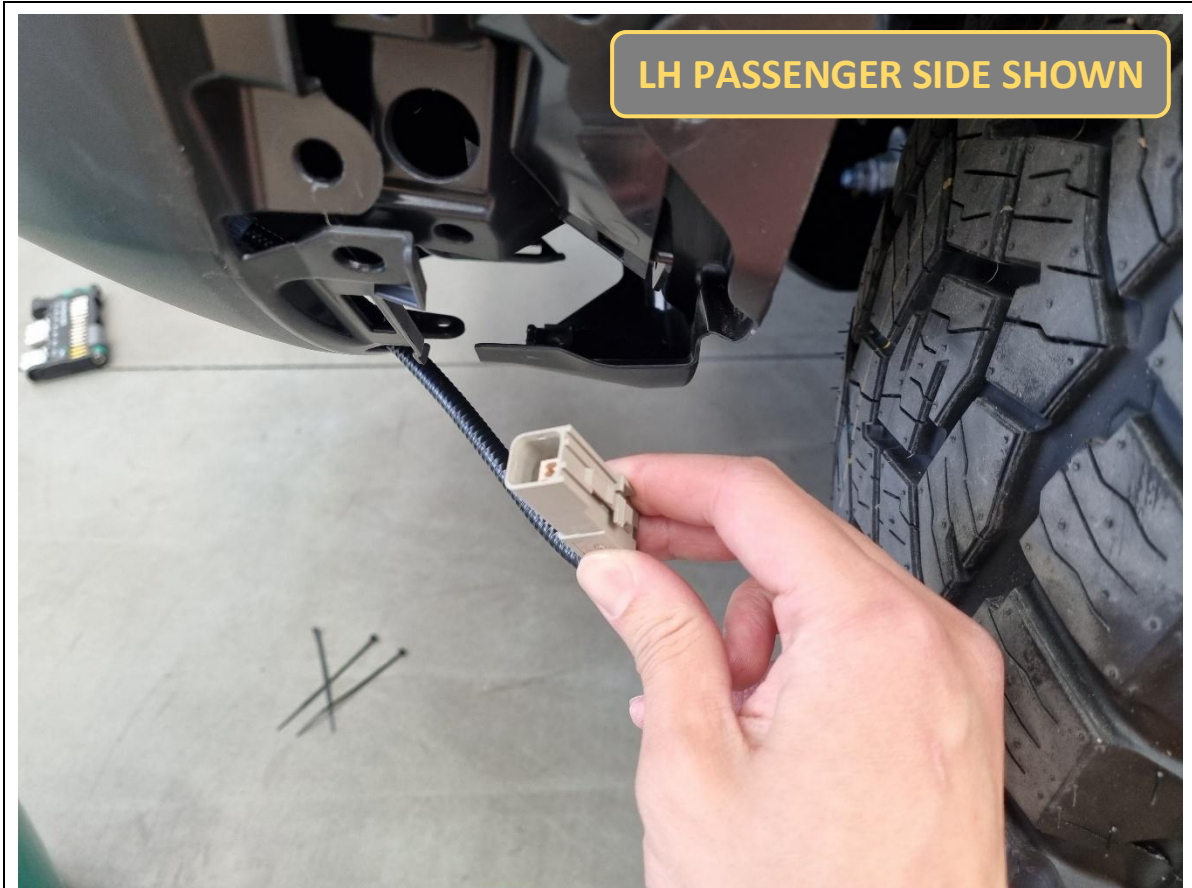

18. On the passenger side, do the same and disconnect 1x bumper harness connector. This connector has a single unlocking tab that can be pressed down with a thumb.

**TOOLS REQUIRED**

Flat blade screwdriver (optional)

**FASTENERS**



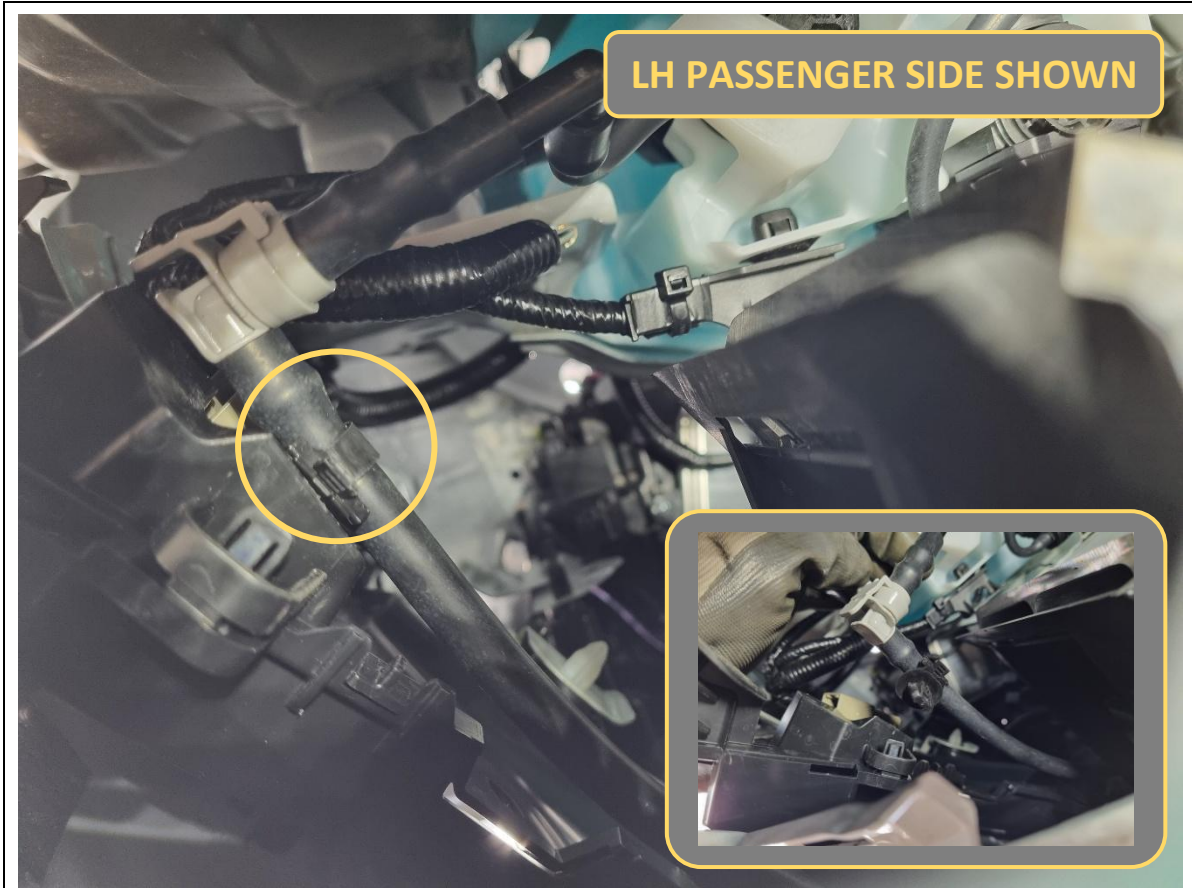

**LH PASSENGER SIDE SHOWN**

19. On the passenger side, there is a headlight washer hose that is clipped into the bumper in one location. Unclip the hose.

**TOOLS REQUIRED**

Flat blade screwdriver  
or  
Trim tool

**FASTENERS**





<p>20. The headlight washer hose needs to be disconnected at the circled location.</p> <p>21. Either clamp the washer hose either side of the connector with cable ties and/or hose line clamps, or place a bucket underneath to let washer fluid drain out (this needs to be re-filled at the end, see maintenance section of Toyota user manual).</p>	<p><b>TOOLS REQUIRED</b></p> <p>Cable ties or Hose line clamp or Bucket</p>
<p>22. Disconnect the washer hose.</p>	<p><b>FASTENERS</b></p>

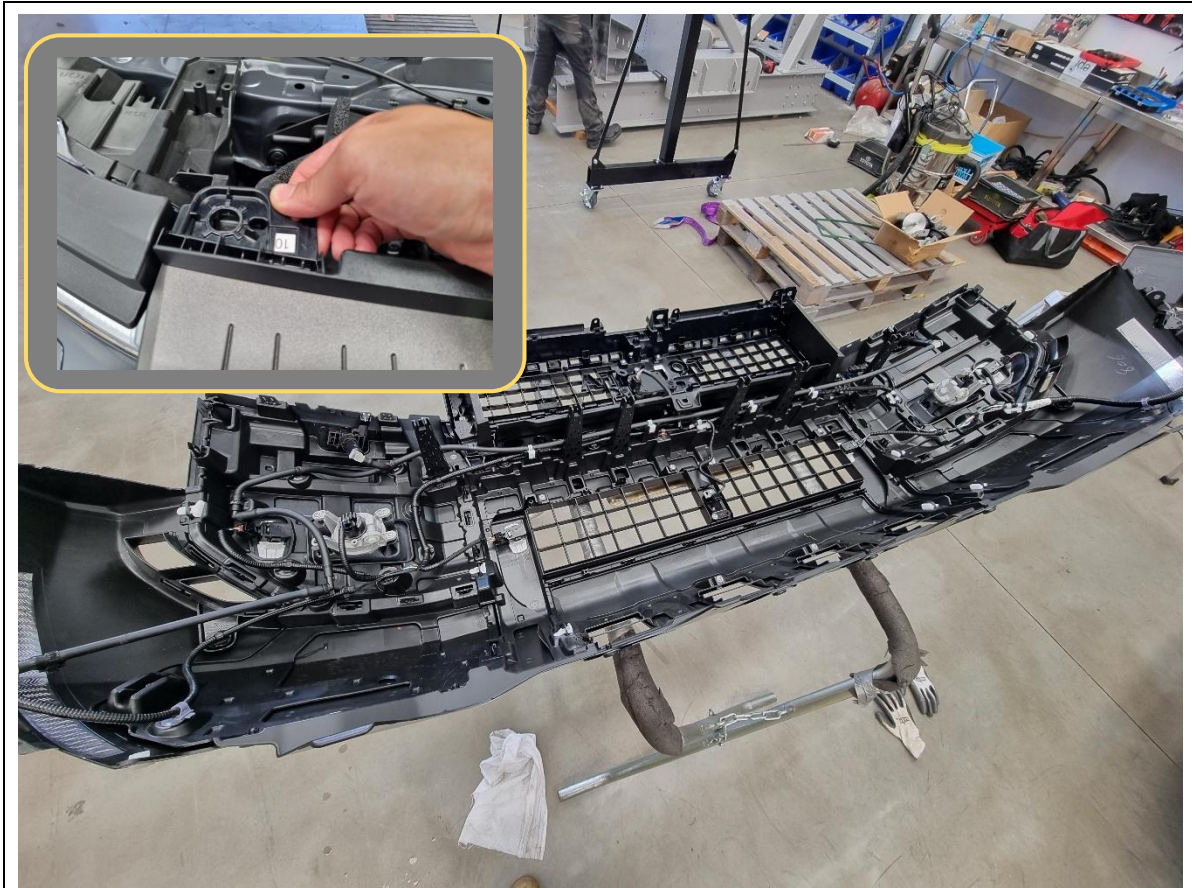

- 23. The bumper and grille are now ready to be removed. Lift the top of the grille tabs up and off the locating pins, then pull the bumper forwards to release any remaining bumper clips.
- 24. Set the bumper and grille aside on a panel stand or a soft blanket.

**TOOLS REQUIRED**

Panel stand  
or  
Soft blanket.

**FASTENERS**



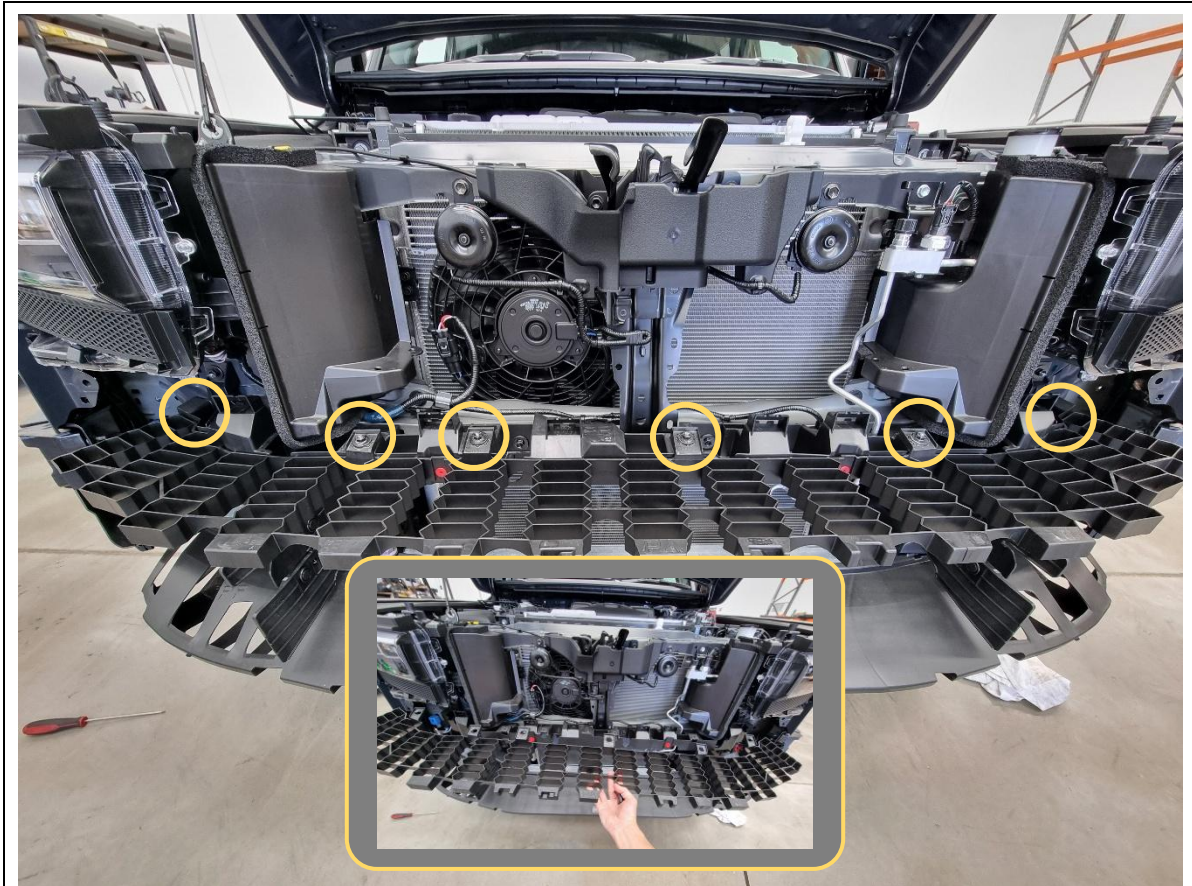

25. Remove 6x 10mm hex bolts holding the front bumper energy absorber to the vehicle.
26. Pull the energy absorber upwards to unclip it from 2x red clips on the vehicle.

**TOOLS REQUIRED**

- 10mm socket/spanner
- Socket extension bar

**FASTENERS**

- 6x 10mm hex bolts

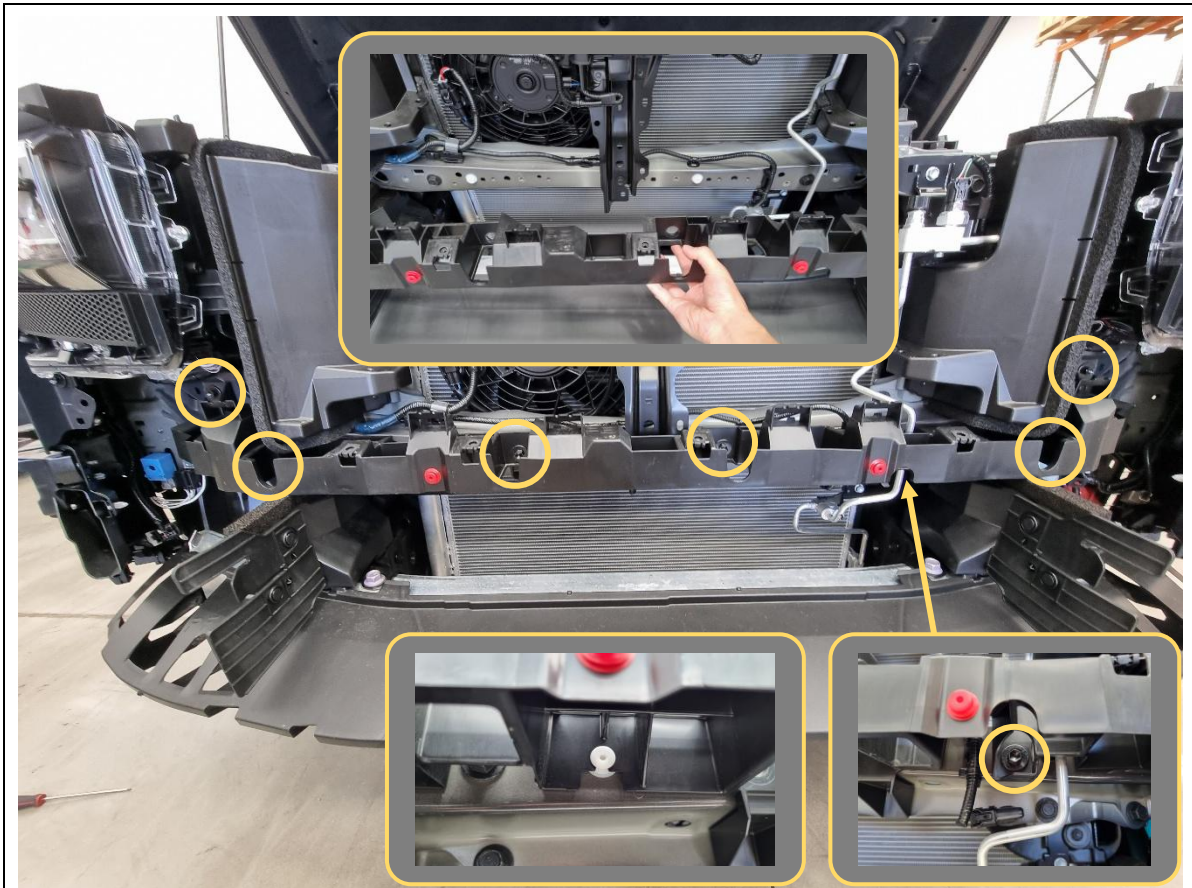

- 27. Remove 7x 10mm hex bolts holding the front bumper upper centre retainer to the vehicle.
- 28. Pull the centre retainer upwards to unclip it from the 2x white clips on the vehicle.

**TOOLS REQUIRED**

- 10mm socket/spanner
- Socket extension bar

**FASTENERS**

- 7x 10mm hex bolts

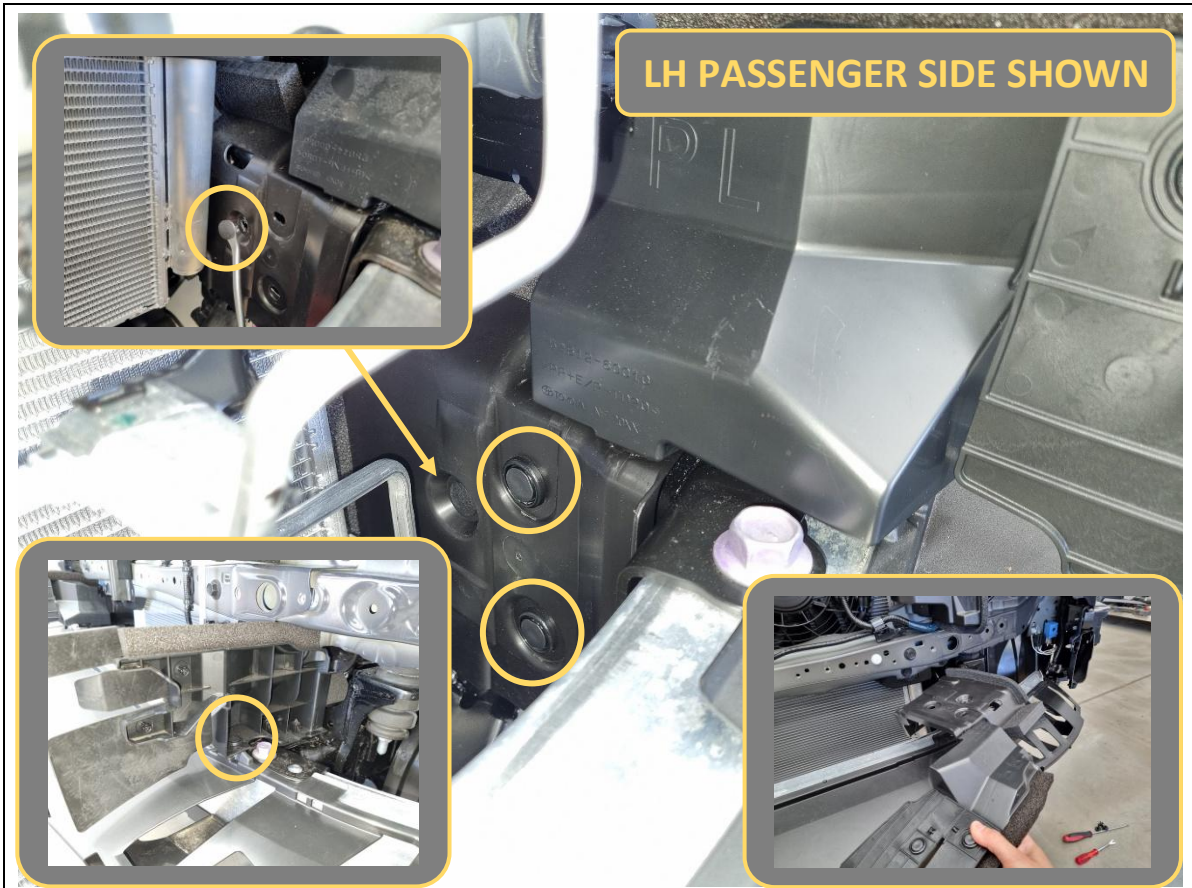

29. Remove 3x push clips and 1x Christmas tree clip holding the air guides to the inside of each chassis rail.

30. Fully remove and discard the 2x air guides.

**TOOLS REQUIRED**

Flat blade screwdriver  
or  
Trim tool

**FASTENERS**

6x plastic push clips  
2x Christmas tree clips



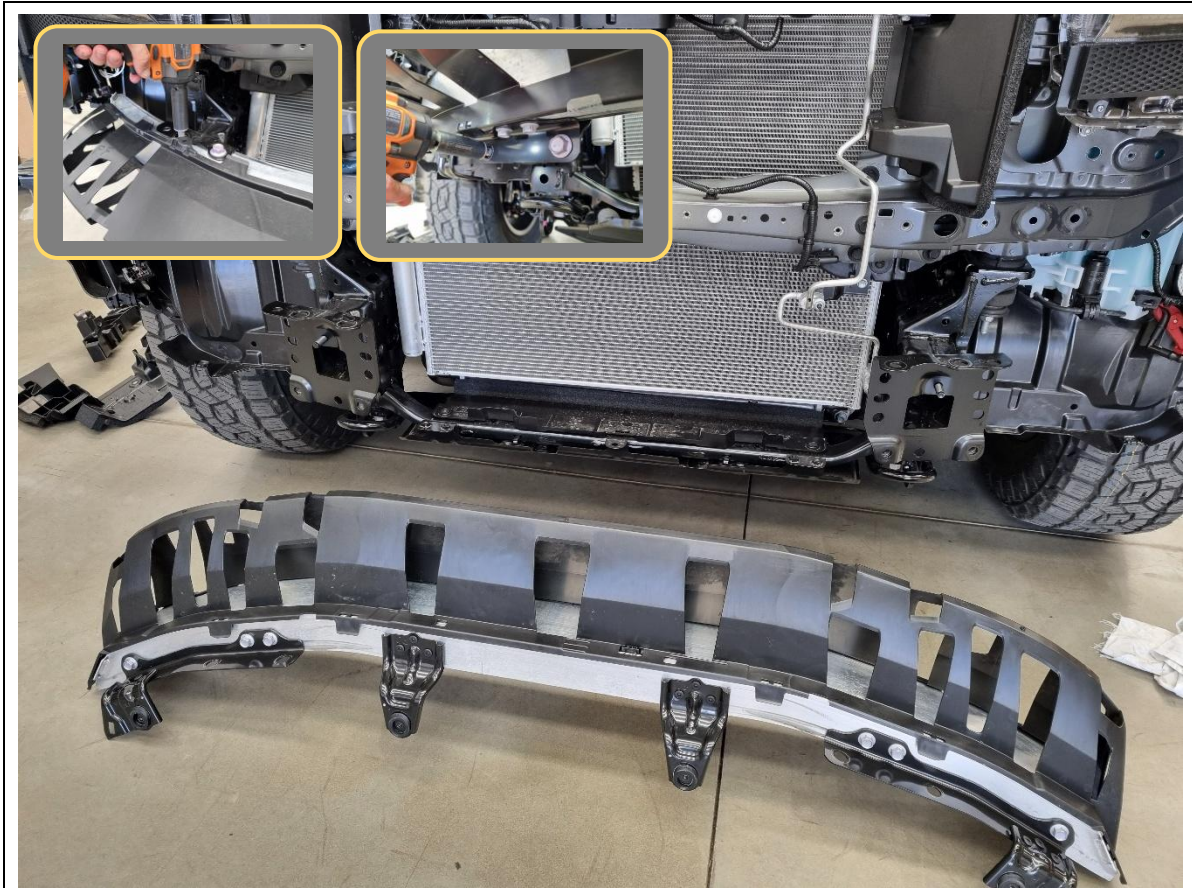

31. Remove 8x 17mm hex bolts (4x per side) holding the crash beam to the chassis.

Retain 4x of the bolts for re-use.

**TOOLS REQUIRED**

17mm socket/spanner

**FASTENERS**

8x 17mm hex bolts

Retain for re-assembly

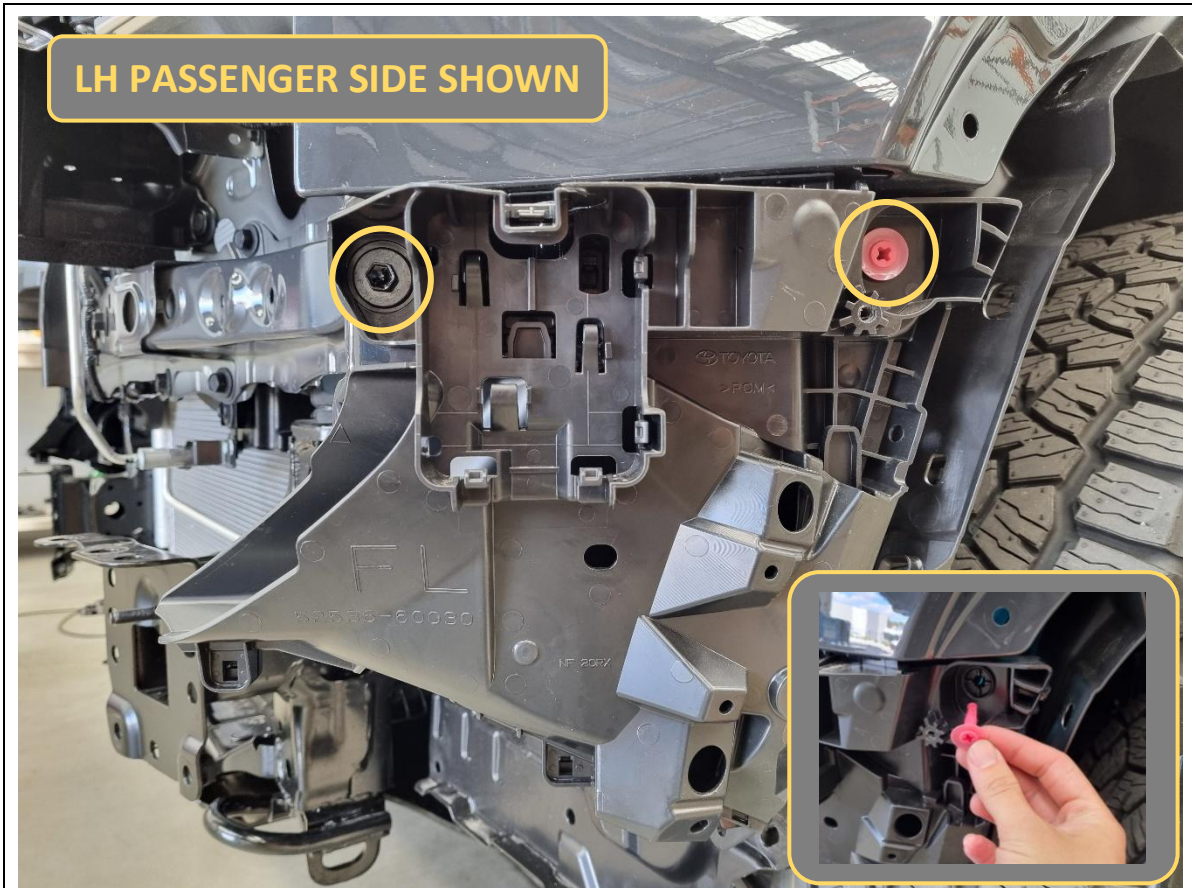

- 32. Remove 1x 10mm hex bolt holding the bumper side retainer. Do this on both sides of the vehicle.
- 33. Remove 1x red plastic clip by inserting a Phillips head screwdriver and rotating the clip anti-clockwise. Do this on both sides of the vehicle.

**TOOLS REQUIRED**

- 10mm socket
- Phillips head screwdriver
- Flat blade screwdriver  
or  
Trim tool

**FASTENERS**

- 2x 10mm hex bolt
- 2x red plastic clip



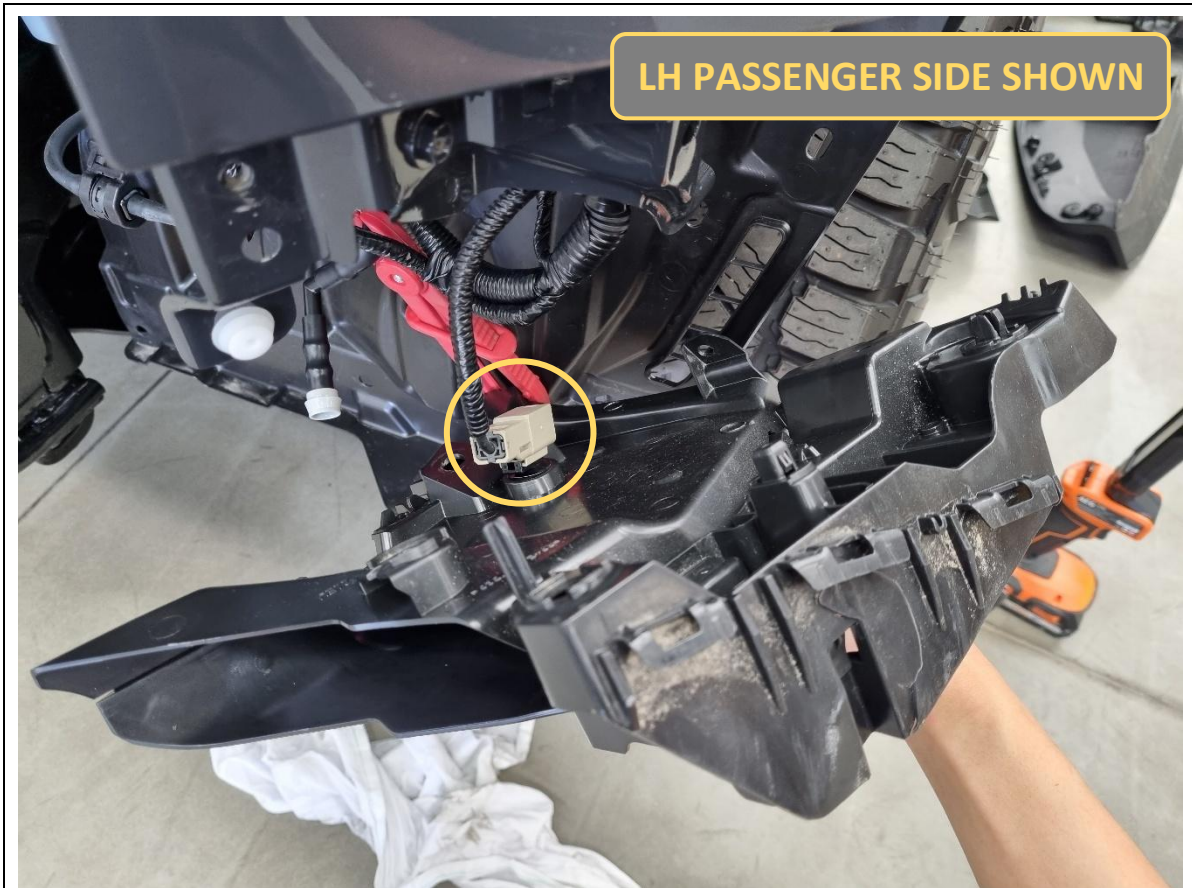

<p>34. First pull the bumper side retainer outwards at the rear to release the rearmost clip/s.</p> <p>35. Then slide the bumper side retainer rearwards towards to the front wheel to release the front clip/s.</p> <p>36. Unclip the bumper harness from the inside of the bumper side retainer.</p>	<p><b>TOOLS REQUIRED</b></p> <p>Flat blade screwdriver or Trim tool</p>
<p>37. Do this on both sides of the vehicle and discard the bumper side retainers</p>	<p><b>FASTENERS</b></p>



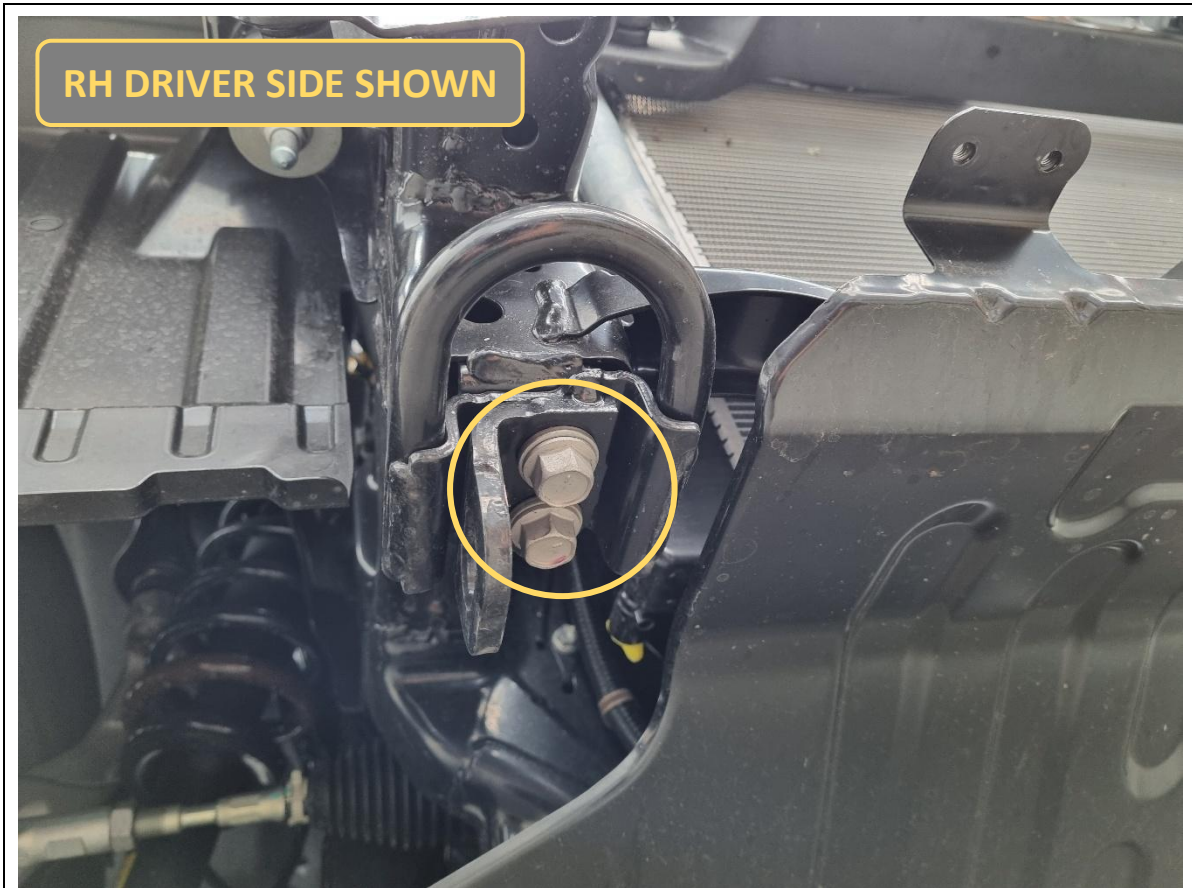

38. On the underside of the chassis, remove 2x 17mm hex bolts holding each tie-down point.

Retain the bolts for re-fitment.

**TOOLS REQUIRED**

17mm socket

**FASTENERS**

4x 17mm hex bolt

Retain for re-assembly

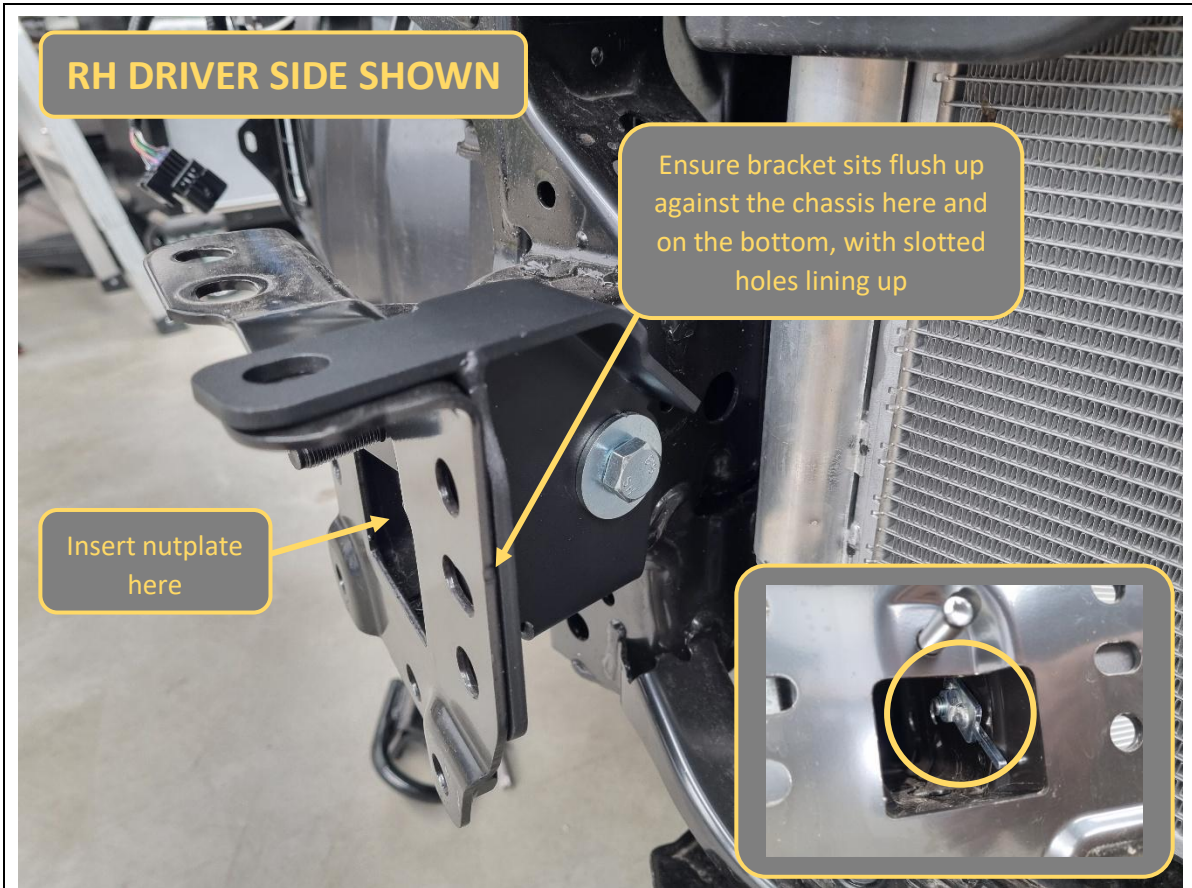

39. Fit the B-1443 inner chassis support brackets to the inside face of each chassis rail.
40. Loosely secure with 1x M12x30 hex bolt, heavy duty washer and nutplate (to be inserted through the front opening of the chassis rail, see arrow and inset image).
41. Position the chassis support bracket so that the bottom flange is sitting flush up against the bottom of the chassis rail, and that the side flange is sitting flush up against the back face of the front of the chassis rail, with the slotted holes lining up.
42. Once aligned, tighten the M12x30 hex bolt.

**TOOLS REQUIRED**

18/19mm socket/spanner

**FASTENERS**

2x M12x30 hex bolt  
2x M12 heavy duty washer  
2x M12 nutplate

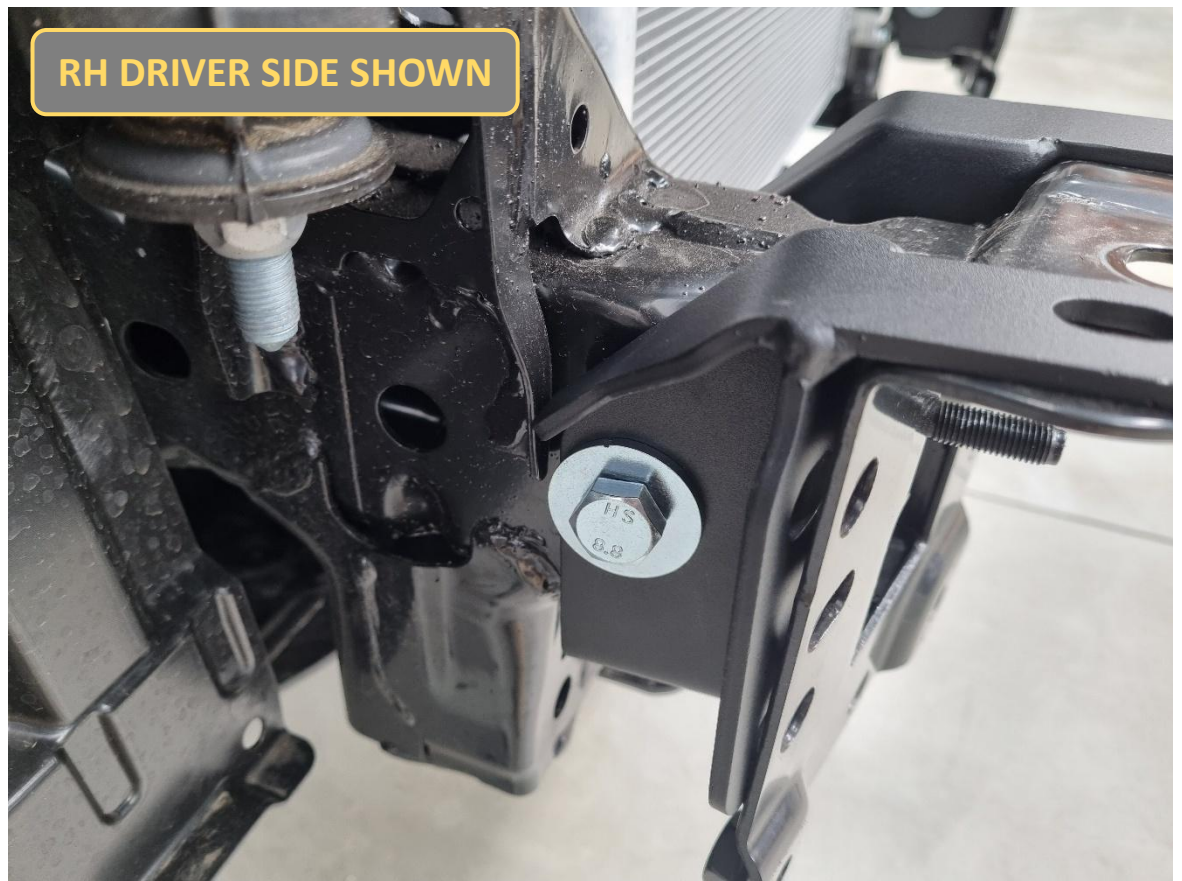

43. Fit the B-1142 outer chassis support brackets to the outside of each chassis rail, and secure/align in the same manner as the inner chassis support brackets.

**TOOLS REQUIRED**

18/19mm socket/spanner

**FASTENERS**

2x M12x30 hex bolt  
2x M12 heavy duty washer  
2x M12 nutplate



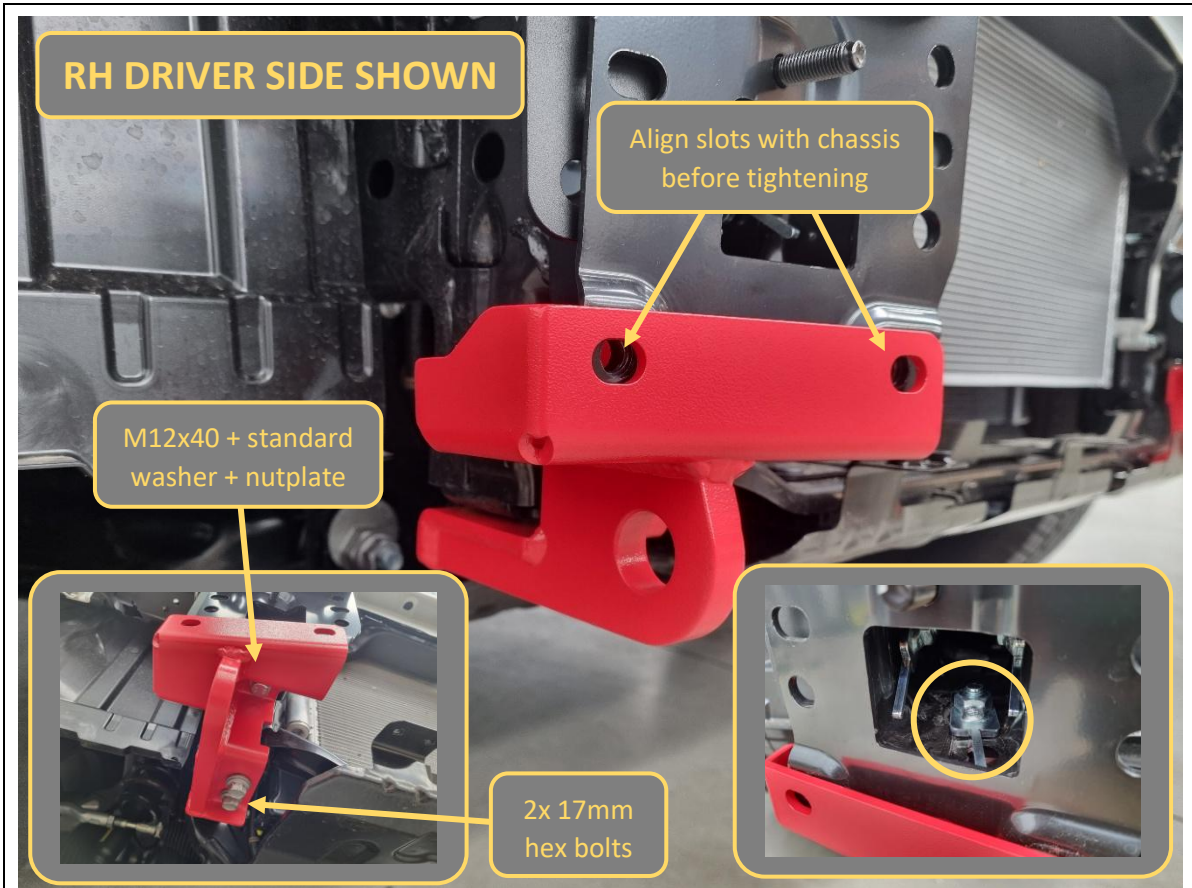

<p>44. Fit the tow points to the underside of the chassis.</p> <p>45. Loosely secure the rear of the tow point with the same 2x 17mm hex bolts as the factory tie-down points.</p> <p>46. Loosely secure the underside tow point through the 2x chassis support brackets and into the chassis with 1x M12x40 hex bolt, standard washer and nutplate (inserted through front face of chassis rail).</p> <p>47. Align the tow point so that the front slots are in line with the chassis rail holes, then fully tighten all tow points.</p>	<p><b>TOOLS REQUIRED</b></p> <p>17mm socket/spanner 18/19mm socket/spanner</p>
	<p><b>FASTENERS</b></p> <p>4x 17mm hex bolt (retained) 2x M12x40 hex bolt 2x M12 standard washer 2x M12 nutplate</p>

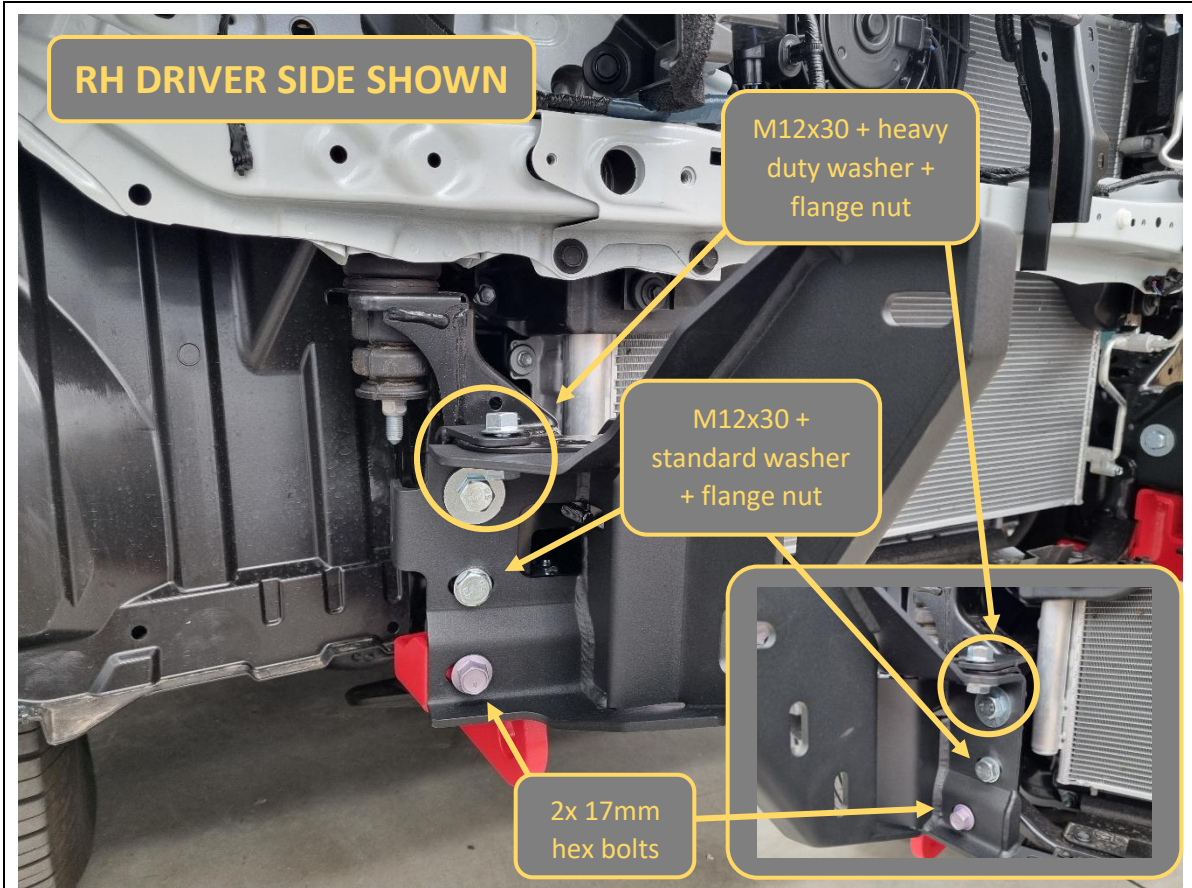

<p>48. Loosely fit the impact assemblies to the front of each chassis rail.</p> <p>49. Loosely secure each impact assembly with:</p> <ul style="list-style-type: none"> <li>a. 2x 17mm hex bolts (retained from factory crash beam)</li> <li>b. 6x M12x30 hex bolts</li> <li>c. 4x M12 heavy duty washers (use on top 4x M12 bolts)</li> <li>d. 2x M12 standard washers (use on lower 2x M12 bolts)</li> <li>e. 6x M12 flange nuts</li> </ul>	<p><b>TOOLS REQUIRED</b></p>
	<p><b>FASTENERS</b></p> <p>4x 17mm hex bolt (retained) 12x M12x30 hex bolt 8x M12 heavy duty washer 4x M12 standard washer 12x M12 flange nut</p>

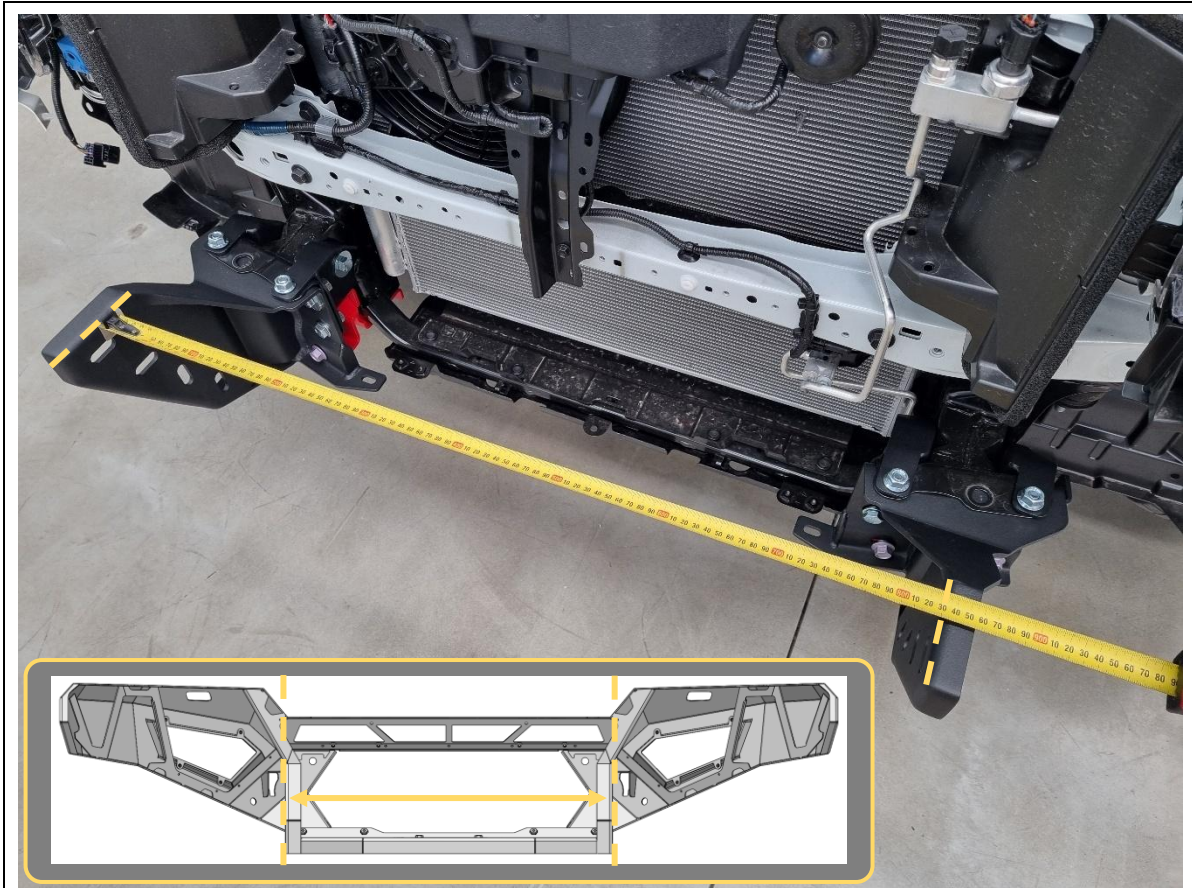

<p>50. Measure the distance between the outside faces of the uprights on the bull bar using a tape measure. Write the distance below for reference if required:</p> <p>Bar upright width = _____ mm</p>	<p><b>TOOLS REQUIRED</b></p> <p>Tape measure</p> <p>17mm socket/spanner</p> <p>18/19mm socket/spanner</p>
<p>51. Adjust the impact assemblies by sliding left/right on the slots, such that the distance between the inner mounting faces of the impact assemblies are 2-5mm more than the bull bar distance. Ensure the mount faces are vertically upright and symmetric left/right on the vehicle (measure to the corners of the headlights or similar to check).</p> <p>52. Once adjusted, tighten all bolts securing the impact assemblies to the chassis/braces/tow points.</p> <p>53. Re-check the distance and re-adjust if required.</p>	<p><b>FASTENERS</b></p>



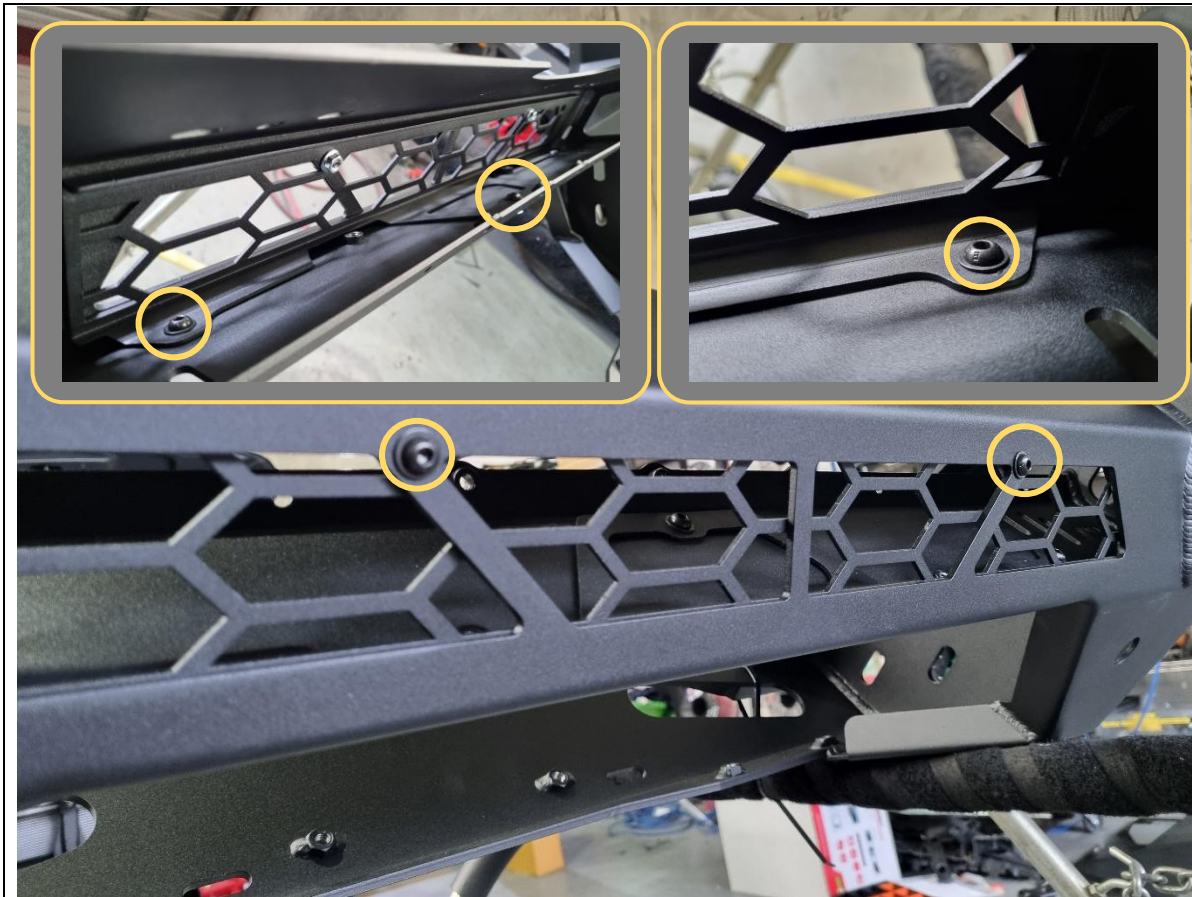

54. Fit the B-1434 light bar mesh infill to the inside of centre section the bull bar. Insert the middle tab in the bar first, then rotate to get the rest of the mesh in.

Note: Fitment of this part is required on all bars.

55. Secure the infill with 5x M6x12 black button head bolts, black flat washers and flange nuts. For the bottom 3x bolts, have the bolt head facing upwards for better visual appearance.

**TOOLS REQUIRED**

4mm hex/Allen key

**FASTENERS**

5x M6x12 black button head bolt  
5x M6 black flat washer  
5x M6 flange nut

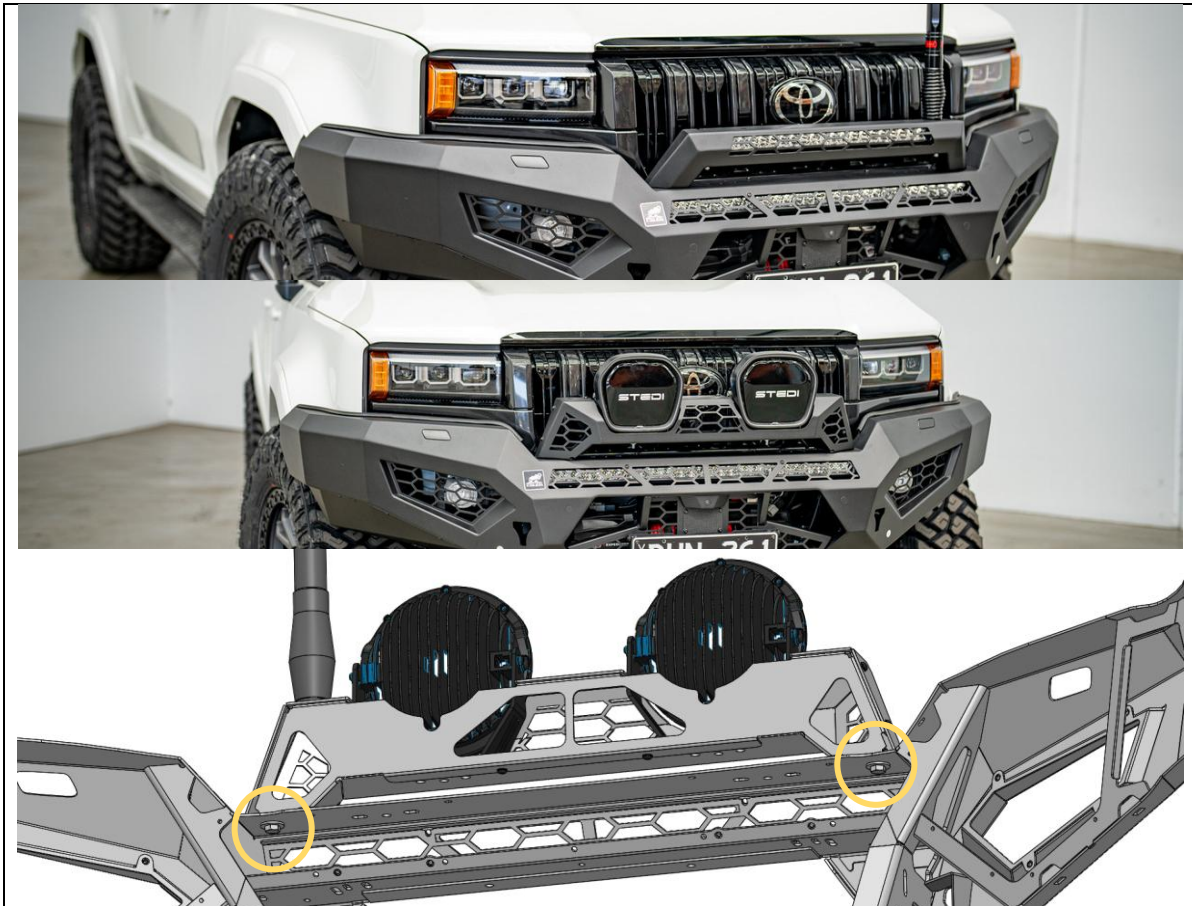

56. If fitting driving lights, stealth hoop, round hoop or rally hoop to this bar, this is also the most convenient time to do so. It is still possible later, but it is more difficult.

Note: Bolt head must be facing down for fitment of rally hoops.

**TOOLS REQUIRED**

Supplied with accessories

**FASTENERS**

Supplied with accessories





<p>57. If fitting an integrated light bar, do so now.</p> <p>This bar is designed to fit the Offroad Animal 32-inch light bar. If fitting this light bar, assemble the light bar with legs facing <u>outwards</u>, and line it up with the slots in the centre gusset. Secure with M6 fasteners supplied with the light.</p> <p>This bar can accommodate most other “30-32inch” size single row light bars. Stedi ST3K light bars require legs facing <u>outwards</u>.</p>	<p><b>TOOLS REQUIRED</b></p> <p>Supplied with accessories</p>
	<p><b>FASTENERS</b></p> <p>Supplied with accessories</p>



58. Fit 10x M6 cage nuts into the rectangular slots in bottom of wing (5x per side).

There should be two types of M6 cage nuts supplied. There are 10x cage nuts suited for thicker 3mm sheet metal, which are to be used here. The other 4x cage nuts are suited for thinner 2mm sheet metal and will be used later.

Use a small flat blade screwdriver to push the edge of the cage to engage with the slot to aid fitting.

**TOOLS REQUIRED**

Flat blade screwdriver

**FASTENERS**

10x M6 cage nuts (to suit 3mm sheet metal)

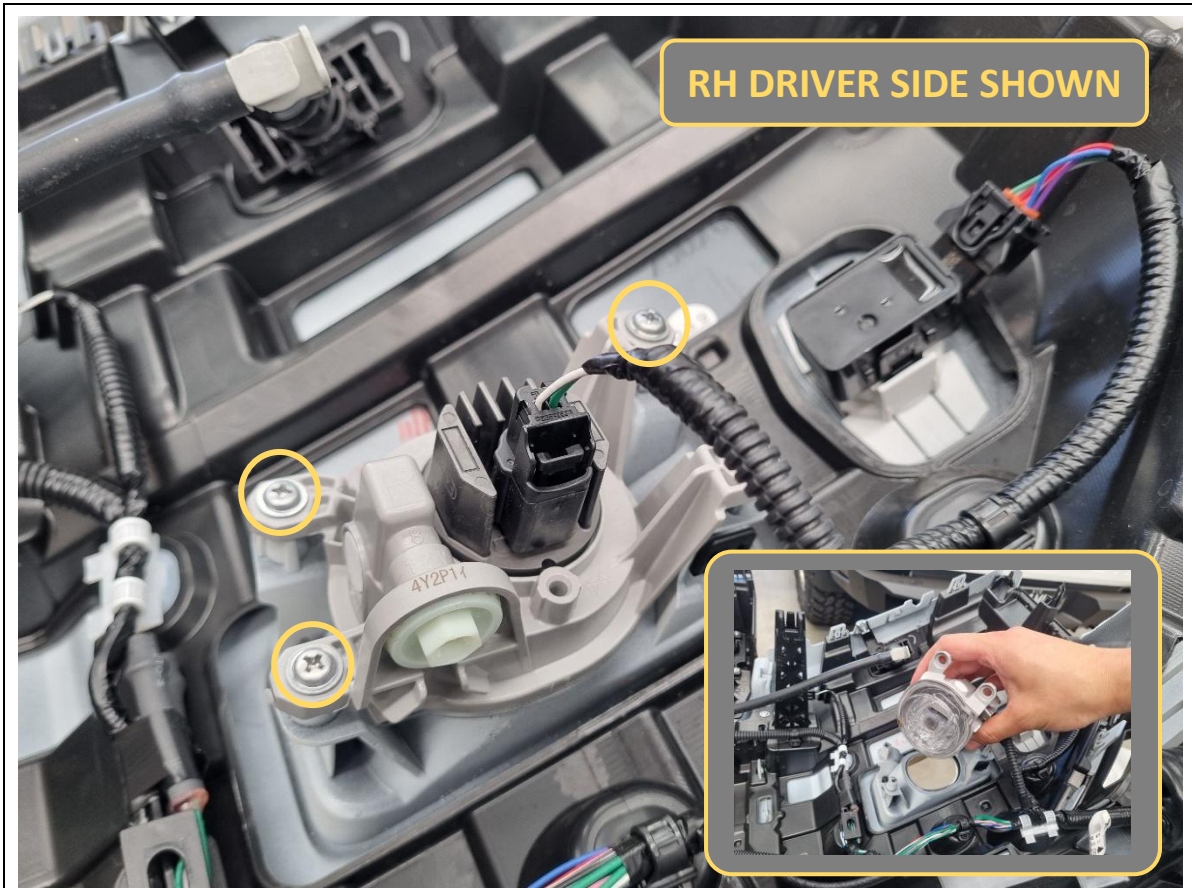

It is now time to strip the bumper.

- 59. Unplug the fog lights from the bumper harness.
- 60. Remove 3x Phillips head screws securing each fog light to the bumper and set aside.

**TOOLS REQUIRED**

Phillips head screwdriver

**FASTENERS**

6x Phillips head screws





61. Locate all 4x parking sensors and label their position and orientation (eg. outer left, inner left, inner right, outer right) with a marker pen and masking tape.
62. Unclip each parking sensor by spreading apart the plastic tabs on the housing.

**TOOLS REQUIRED**

Marker pen  
Masking tape

**FASTENERS**



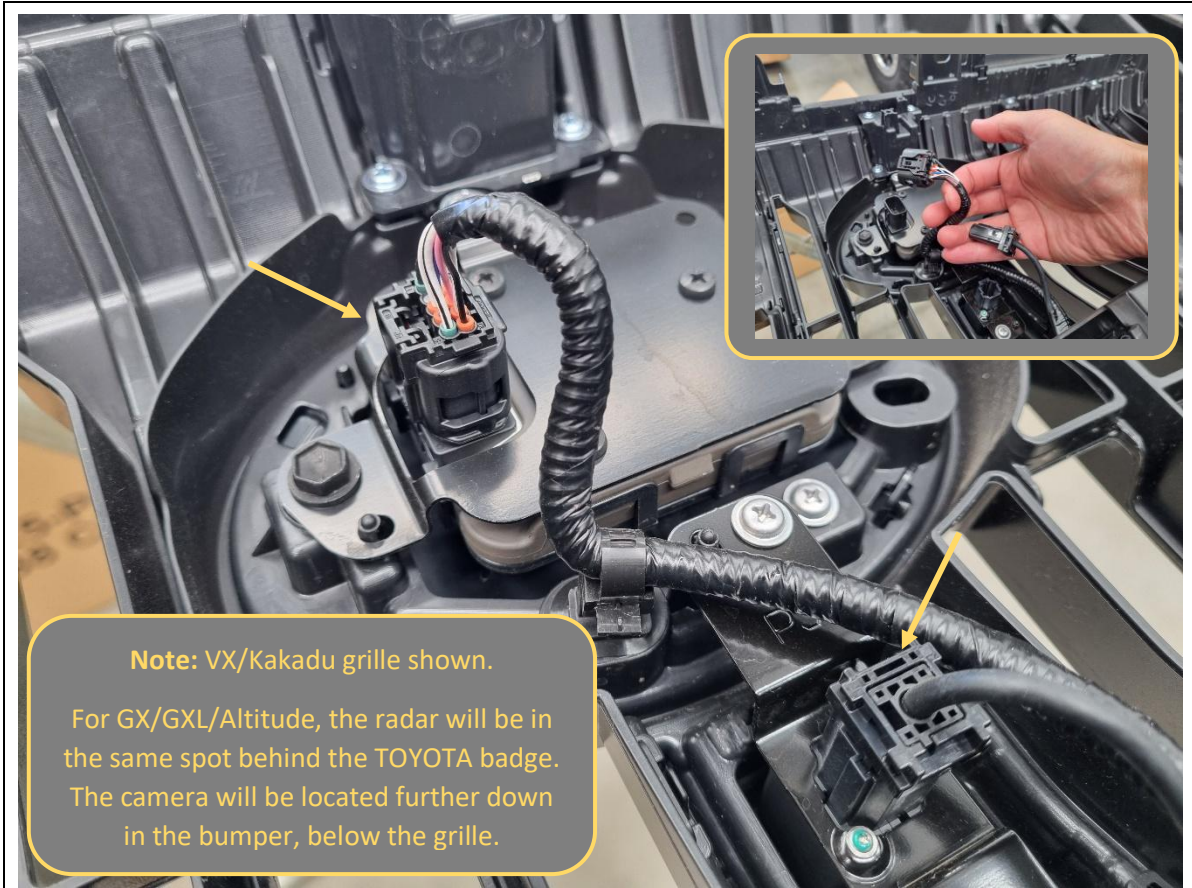

<p>63. Unplug the radar and camera behind the grille.</p>	<p><b>TOOLS REQUIRED</b></p>
	<p><b>FASTENERS</b></p>

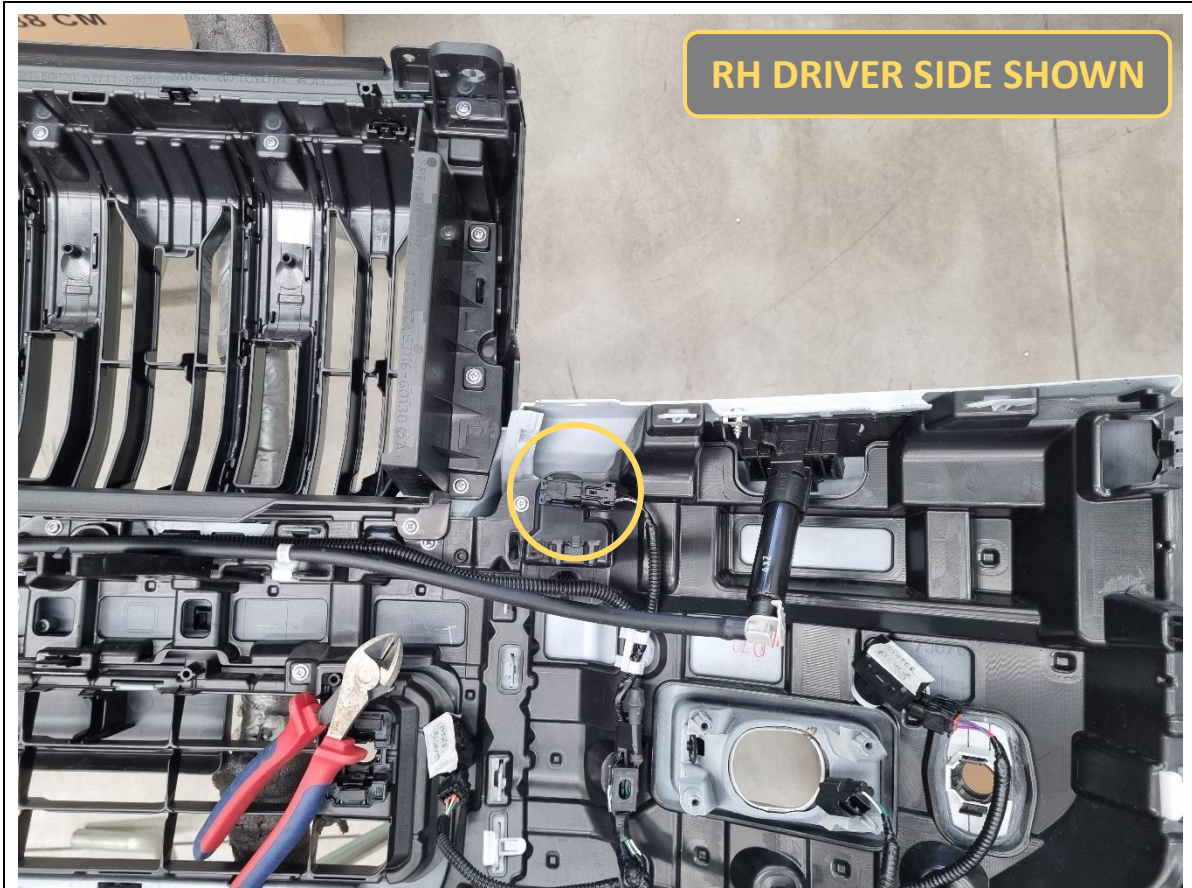

64. On the driver side of the bumper, unclip the blanking plug highlighted. Use a flat blade screwdriver or trim tool to assist.

**TOOLS REQUIRED**

Flat blade screwdriver  
or  
Trim tool

**FASTENERS**

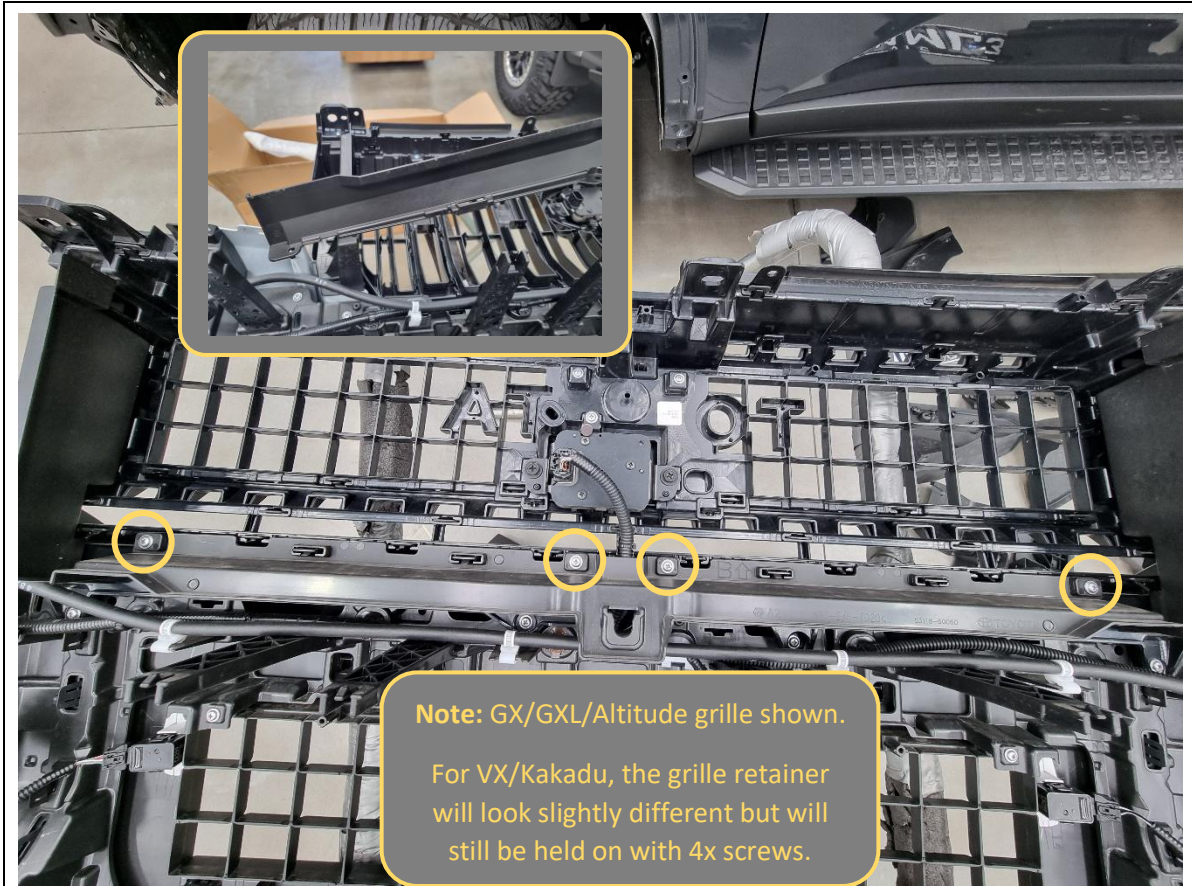

65. Remove 4x Phillips head screws holding the lower grille retainer.

**TOOLS REQUIRED**

Phillips head screwdriver

**FASTENERS**

4x Phillips head screws



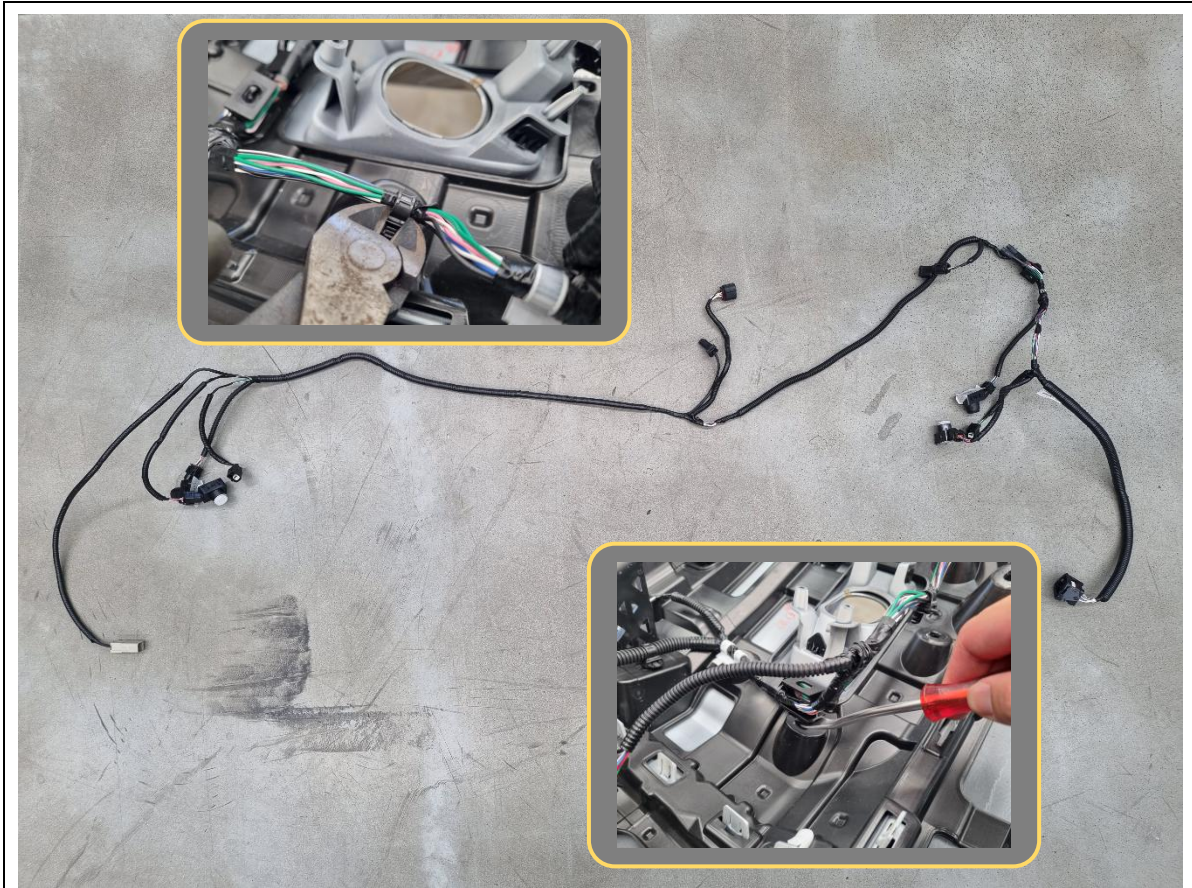

66. Fully strip the bumper wiring harness off the bumper by either unclipping the harness with a flat blade screwdriver or trim tool, or by carefully cutting off the cable tie clips with side cutters (take care not to cut the wires).

**TOOLS REQUIRED**

Flat blade screwdriver  
or  
Trim tool  
or  
Side cutters

**FASTENERS**



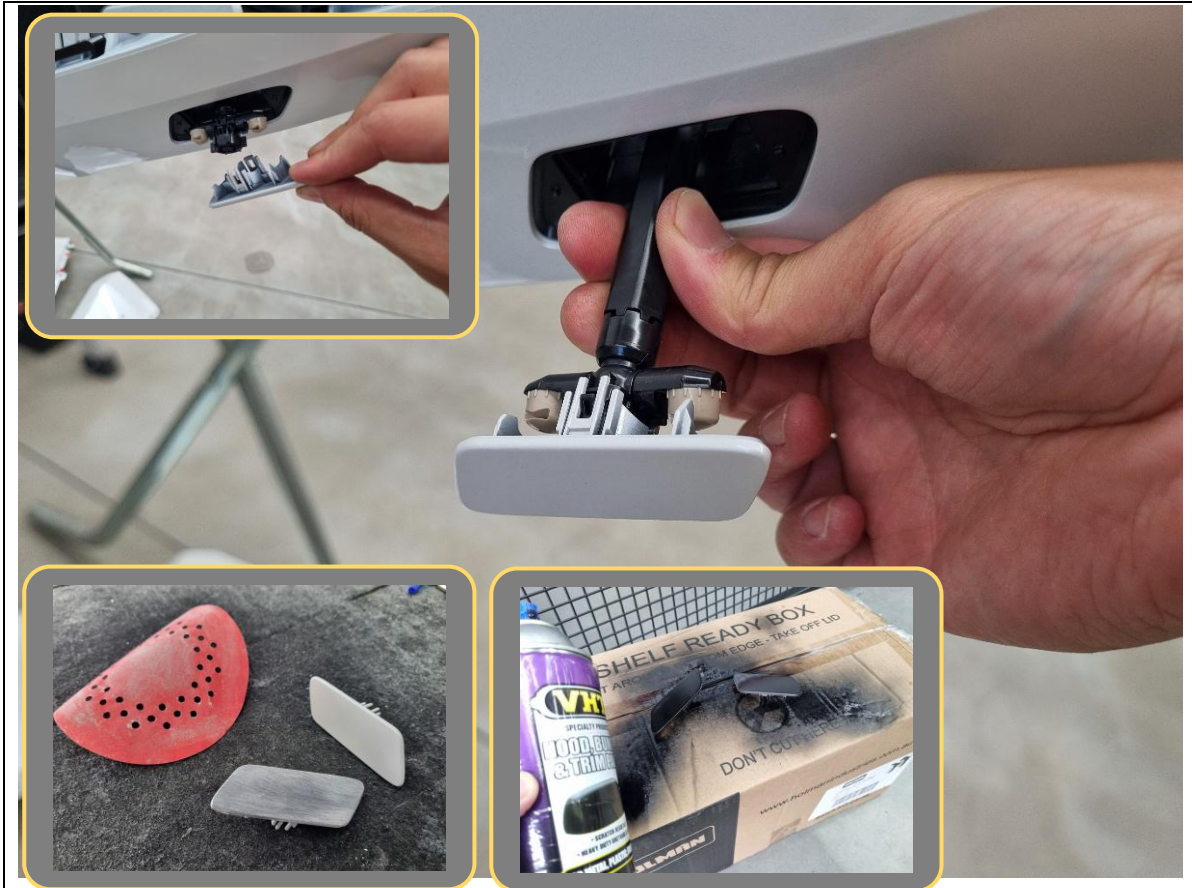

67. Using your hands, pull out the headlight washers on each of the bumper.

68. Unclip the headlight washer cover cap and set aside in a safe place.

69. It is highly recommended to match the colour of the headlight washer cover cap with the bull bar. Use sandpaper to scour the surface of the cover cap, then evenly apply at least 2 coats of spray paint and allow to dry.

**TOOLS REQUIRED**

**FASTENERS**

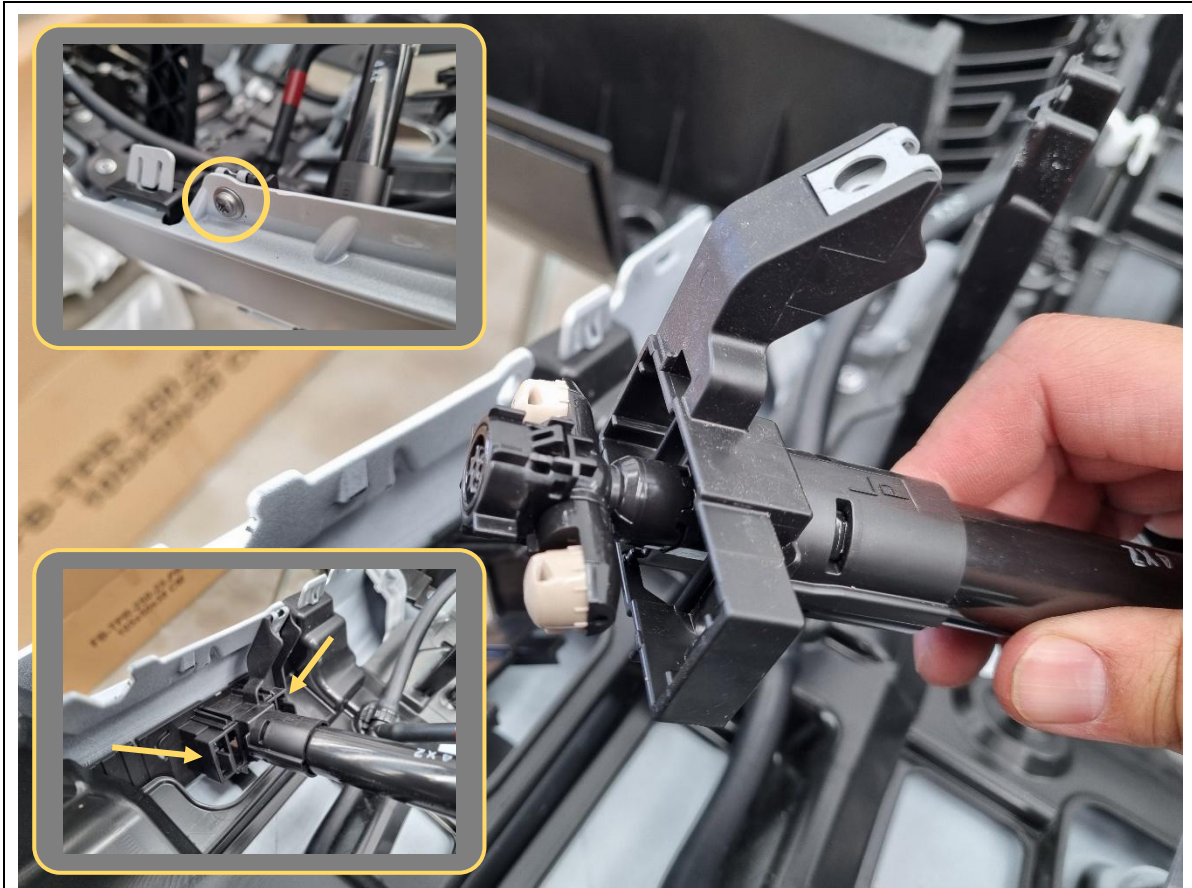

- 70. Remove 1x Phillips head screw holding each headlight washer unit to the top lip of the bumper (see top inset photo).
- 71. Then press down on the 2x tabs and release the headlight washer unit from the bumper (see bottom inset photo).

**TOOLS REQUIRED**

Phillips head screwdriver

**FASTENERS**

2x Phillips head screws

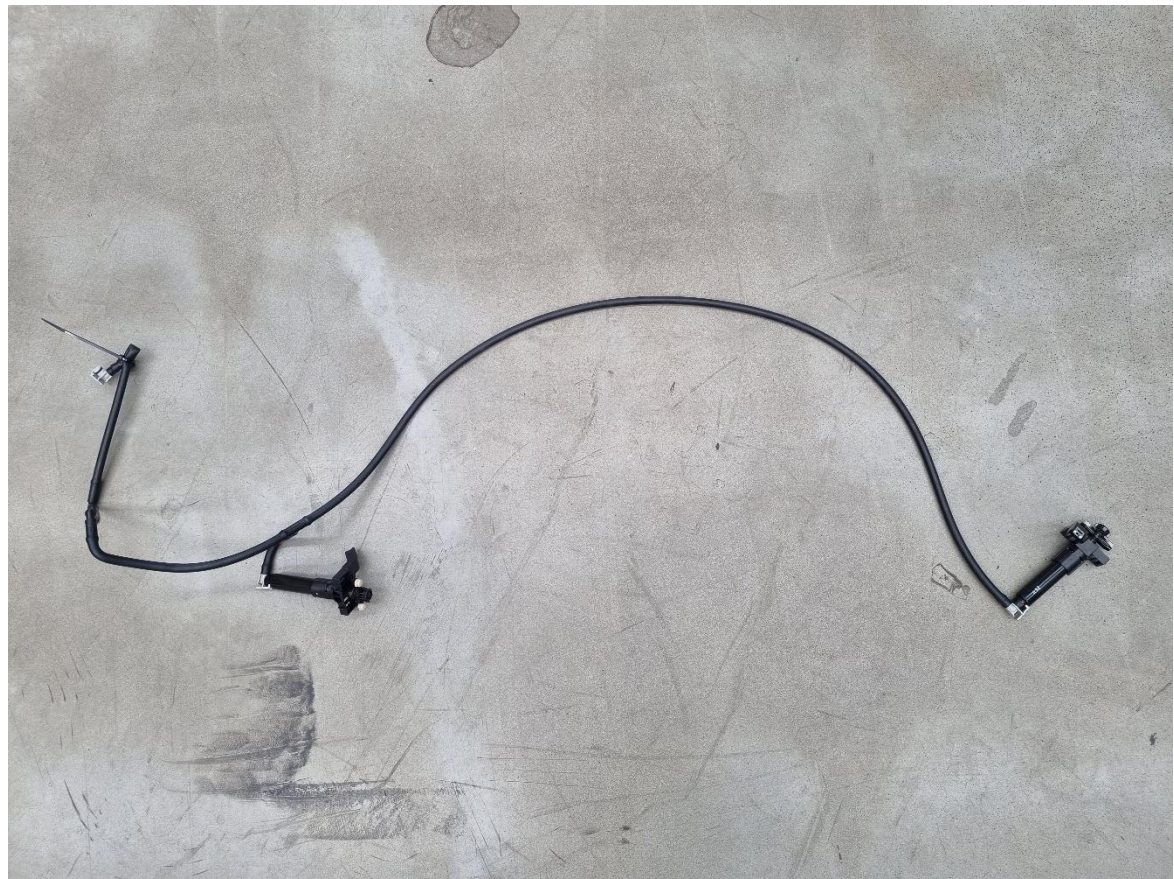

72. Either unclip or cut through the cable tie clips securing the washer hose system to the bumper and set aside.

**TOOLS REQUIRED**

Flat blade screwdriver  
or  
Trim tool  
or  
Side cutters

**FASTENERS**



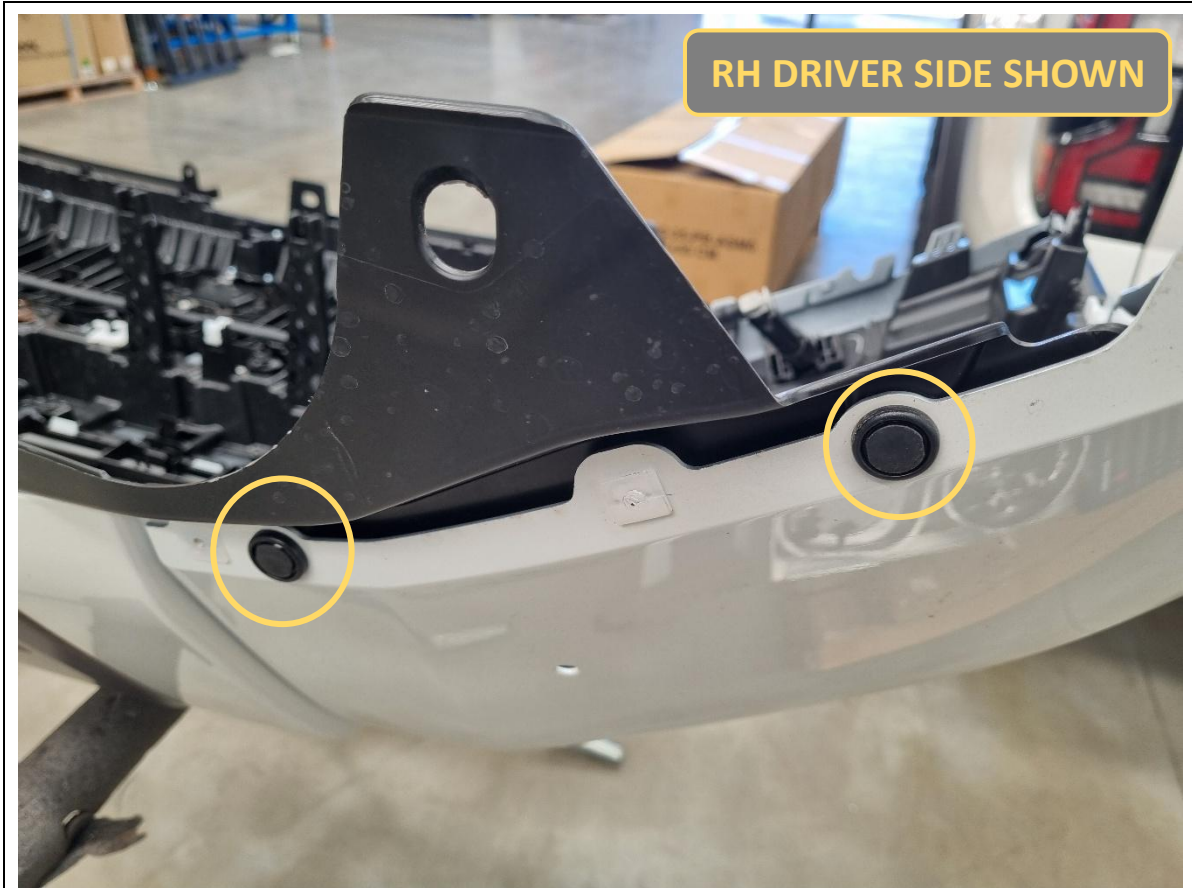

<p>73. Remove 2x plastic push clips on the bottom of the outer bumper extension. Do this for both sides.</p>	<p><b>TOOLS REQUIRED</b></p> <p>Flat blade screwdriver or Trim tool</p>
	<p><b>FASTENERS</b></p> <p>4x plastic push clips</p>



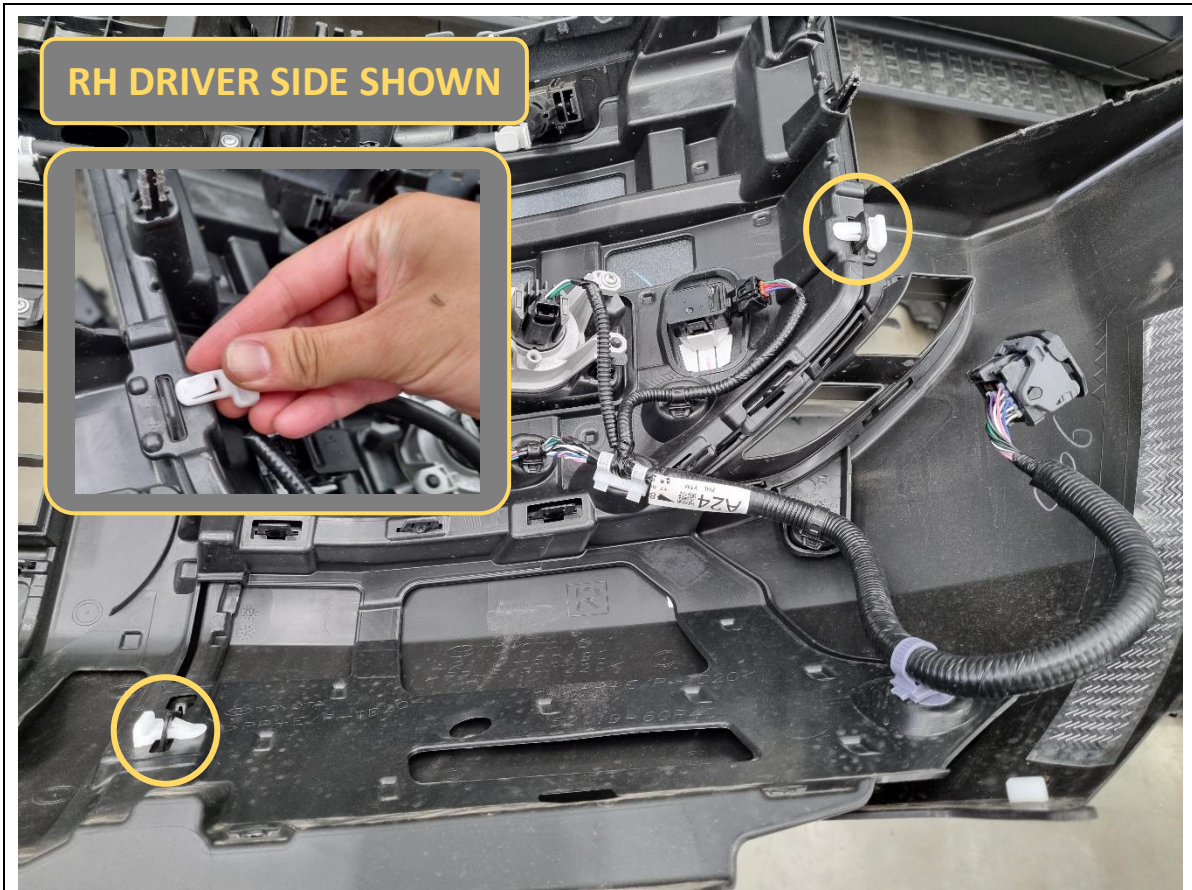

74. Remove 2x white plastic clips on the inside of the outer bumper extension. Do this for both sides.

Press down on the clip and slide through the slotted tab to remove.

**TOOLS REQUIRED**

**FASTENERS**



<p>75. Release 3x tabs to remove the outer bumper extension. Do this for both sides.</p>	<p><b>TOOLS REQUIRED</b></p>
	<p><b>FASTENERS</b></p>

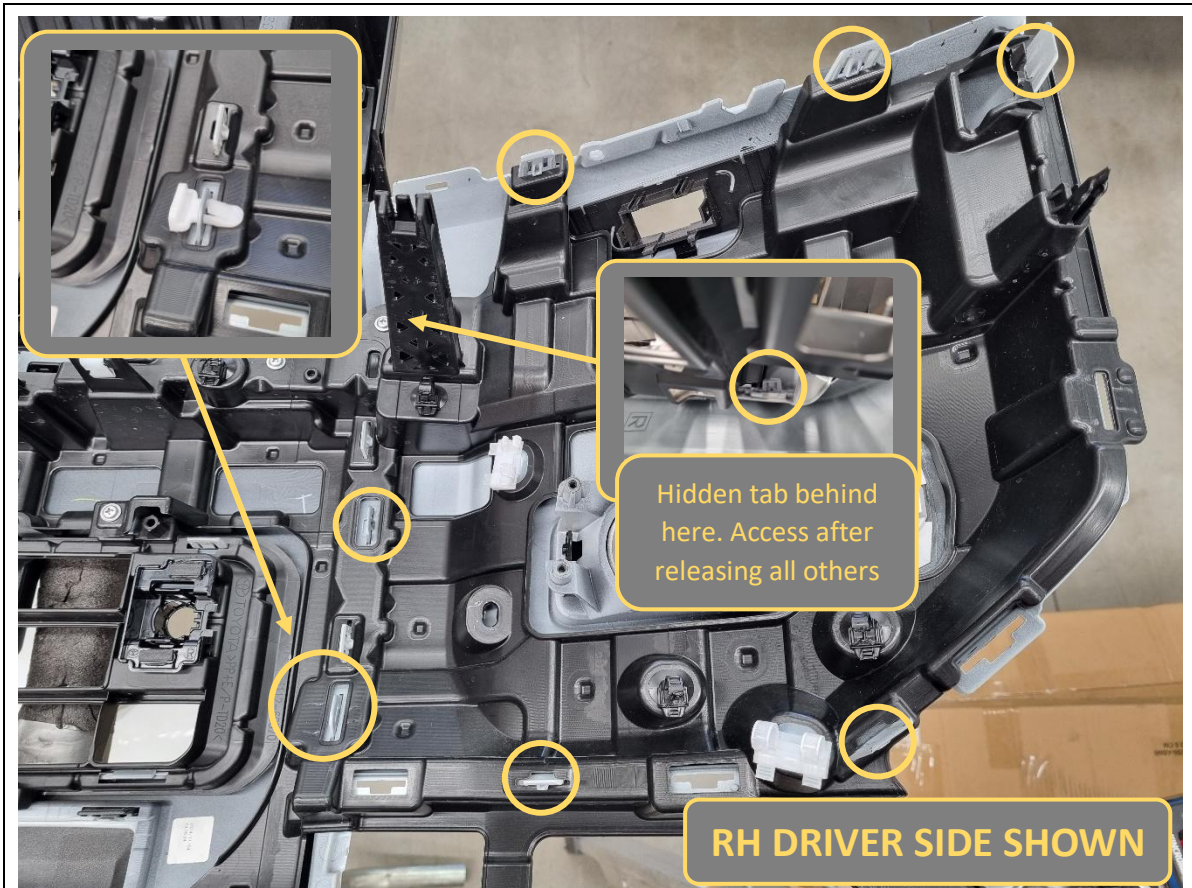

<p>76. Remove 1x white plastic clip on the inside of the bumper insert.</p> <p>77. Release 7x tabs holding the bumper insert and remove.</p> <p>Note: 1x tab is hidden. Release the other 6x first and pry the bumper insert off the main bumper section to access the hidden tab.</p>	<p><b>TOOLS REQUIRED</b></p> <p>Flat blade screwdriver (optional)</p>
<p>78. Repeat for other side.</p>	<p><b>FASTENERS</b></p>





79. Use a combination of heat gun, plastic trim tool and utility knife to peel off the headlight washer holders from each bumper insert.

**TOOLS REQUIRED**

- Heat gun
- Plastic trim tool
- Utility knife

**FASTENERS**





- 80. Use a heat gun to peel off most of the leftover foam tape on the headlight washer holders.
- 81. Then use a cleaning solvent (we found brake cleaner works best) to remove the remaining tape residue until the surface is clean.

**TOOLS REQUIRED**

- Heat gun
- Brake cleaner
- Rag

**FASTENERS**



82. Clean the mounting surfaces of the supplied F-0022 parking sensor holders, the headlight washer holders and the corresponding mounting locations on the inside of the bull bar with isopropyl alcohol or similar and let it dry.

83. There are 3x 3M Primer 94 ampules supplied. Use 2x ampules and apply primer to all the cleaned surfaces, both on the bull bar and on the sensor/headlight washer holders.

**TOOLS REQUIRED**

Isopropyl alcohol  
Rag

**FASTENERS**

2x 3M Primer 94

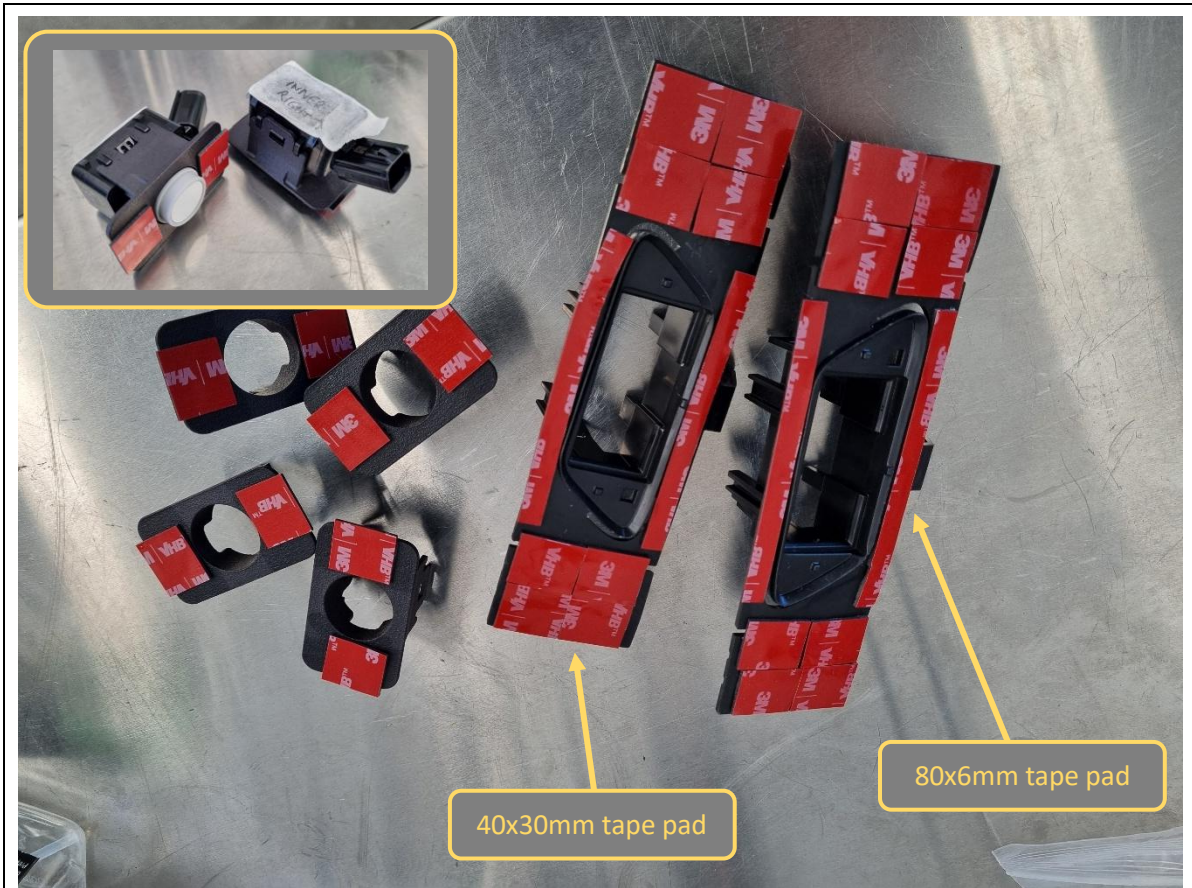

<p><b>Allow at least 5 minutes for the primer to chemically bond to the surfaces before applying tape.</b></p> <p>84. Apply supplied 3M VHB tape from the universal parking sensor tape kit to the F-0022 parking sensor holders as shown.</p> <p>85. Then temporarily unplug the parking sensors from the bumper harness and clip them into the sensor holders (see inset photo).</p> <p>86. Apply supplied 3M VHB tape from the Prado 250 tape kit to the headlight washer holders as shown.</p>	<p><b>TOOLS REQUIRED</b></p>
	<p><b>FASTENERS</b></p>





<p>87. Remove the backing film off the tape on the parking sensor holders (use utility knife or 90 degree pick to assist), then fit to their corresponding positions inside the bull bar.</p> <p>Ensure the rubber isolating ring of the parking sensor fits through the hole in the bar and is not wedged in incorrectly.</p> <p>Ensure the sensor plug orientation matches the installation in the factory bumper.</p>	<p><b>TOOLS REQUIRED</b></p> <p>Utility knife</p>
	<p><b>FASTENERS</b></p>





**RH DRIVER SIDE SHOWN**

- 88. Remove the backing film off the tape on the headlight washer holders (use utility knife to assist), then fit to their corresponding positions inside the bull bar.  
  
Ensure left/right orientation is correct. The headlight washer holder as a L/R marking for identification.
- 89. Add a pea-sized blob of automotive adhesive sealant (we recommended Sikaflex 227) over the sensor/headlight washer holders and inside face of bar to hold to ensure the tape holds position.

**TOOLS REQUIRED**

Utility knife  
Sikaflex

**FASTENERS**



<p>90. The original fog lights can be re-fitted to the bar. Fit the fog lights to the supplied B-1431 fog light brackets and secure with 4x M6x16 black button head bolts, black washers and flange nuts, each.</p>	<p><b>TOOLS REQUIRED</b></p> <p>4mm hex/Allen key</p>
	<p><b>FASTENERS</b></p> <p>8x M6x16 black button head bolt 8x M6 black flat washer 8x M6 flange nut</p>

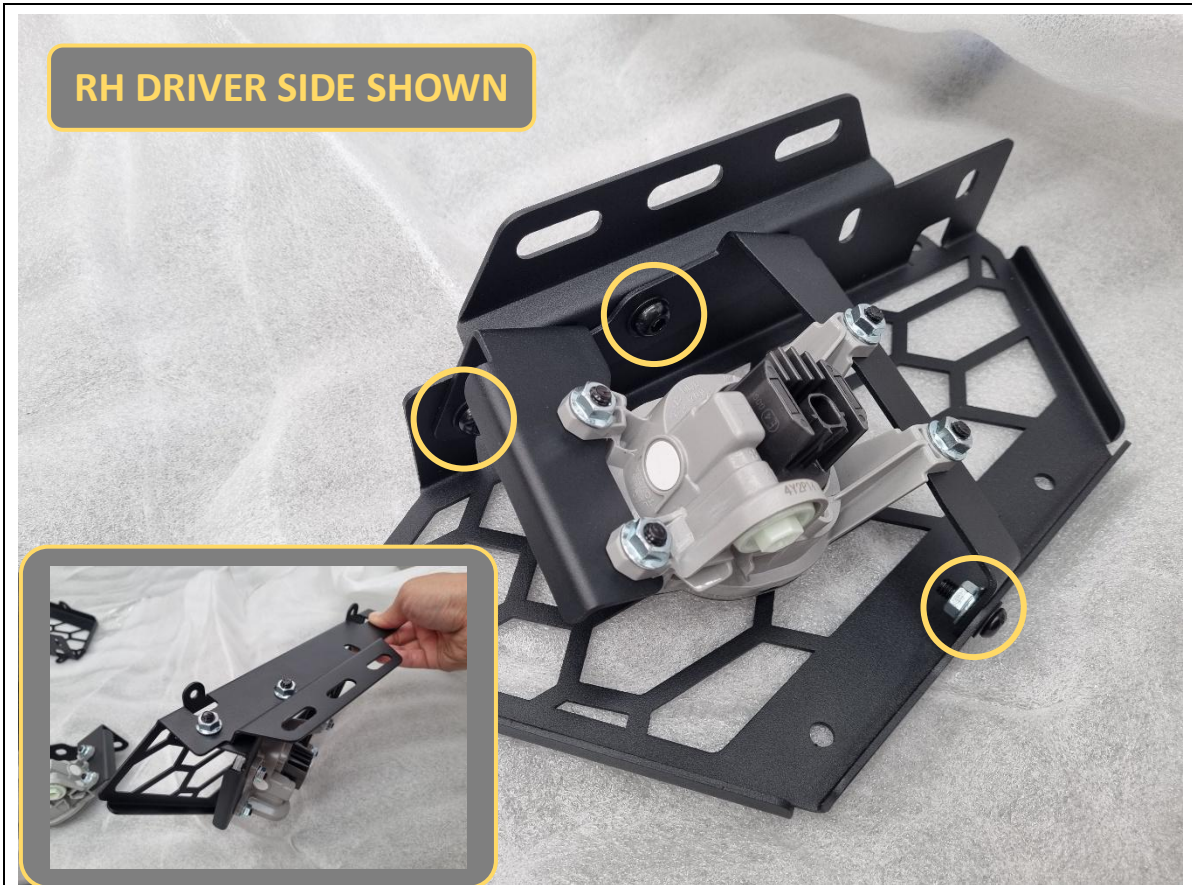

**RH DRIVER SIDE SHOWN**

<p>91. Fit the fog light and bracket to the wing mesh.</p> <p>92. Secure at the bottom with 1x M6x16 black button head bolt, black washer and flange nut.</p> <p>93. Secure at the top with 2x M8x16 black button head bolts, black washers and flange nuts.</p> <p>94. Repeat for the other side.</p>	<p><b>TOOLS REQUIRED</b></p> <p>4mm hex/Allen key 5mm hex/Allen key</p>
	<p><b>FASTENERS</b></p> <p>2x M6x16 black button head bolt 2x M6 black flat washer 2x M6 flange nut</p> <p>4x M8x16 black button head bolt 4x M8 black flat washer 4x M8 flange nut</p>



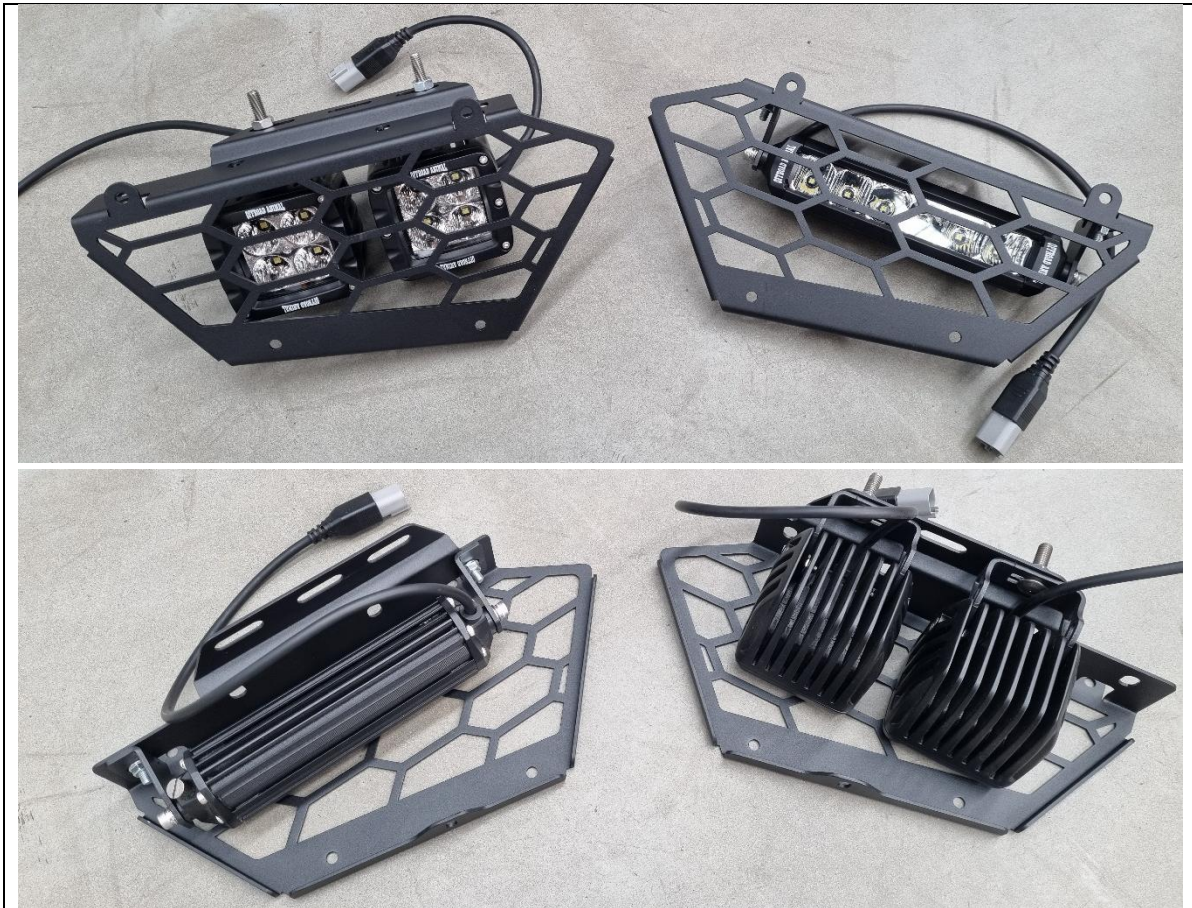

95. Instead of fog lights, there is also the option to fit an 8" light bar or up to two 2"x2" cube lights in each wing mesh, as shown. Or you can fit no lights at all.

**TOOLS REQUIRED**

Supplied with accessories

**FASTENERS**

Supplied with accessories



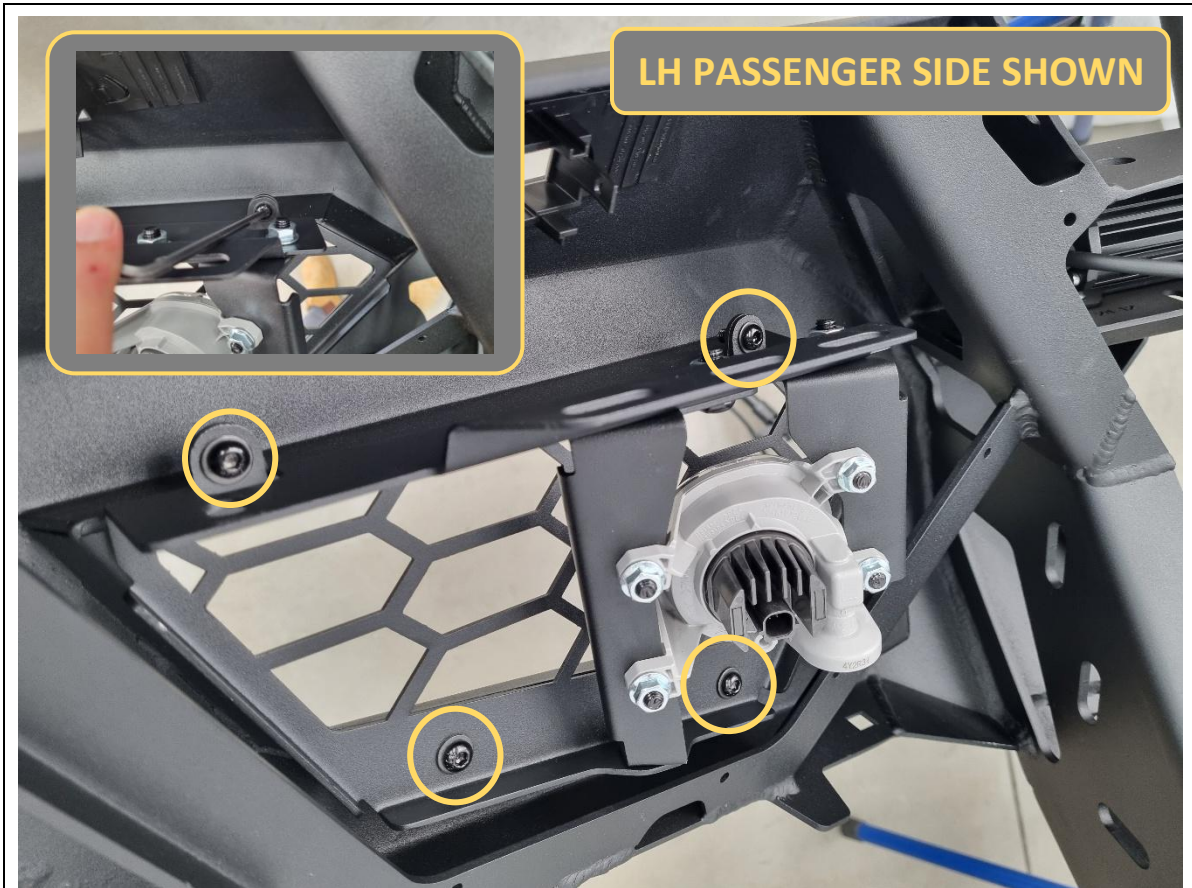

96. Fit the wing meshes with lights to the inside of the bull bar wings. Secure each wing mesh with 4x M6x16 black button head bolts and black washers, into the embedded nuts in the bull bar.

**TOOLS REQUIRED**

4mm hex/Allen key

**FASTENERS**

8x M6x16 black button head bolt  
8x M6 black flat washer



97. Disconnect the headlight washer units from the washer hose. Do this with a bucket as there will be some fluid spilling out.

**TOOLS REQUIRED**

Bucket

**FASTENERS**

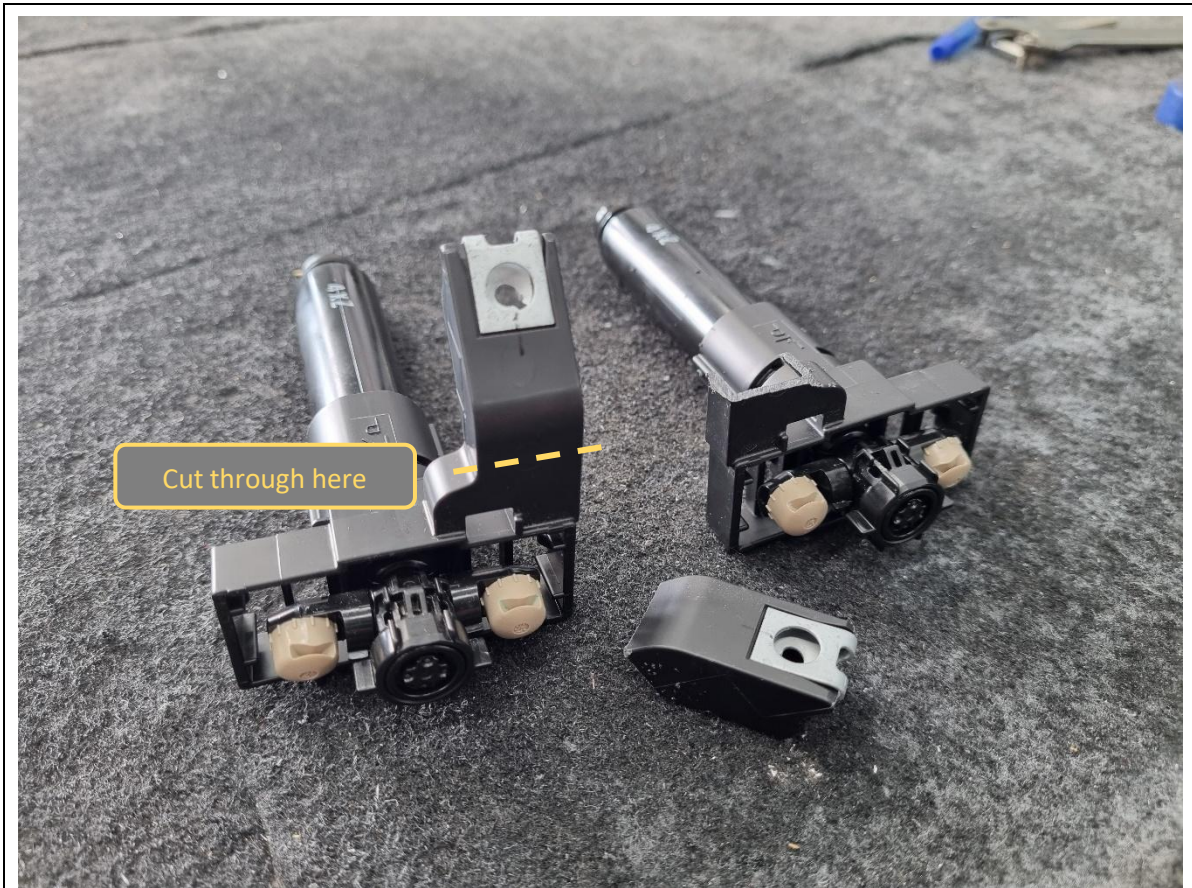

98. Using an air hacksaw or similar cutting tool, cut off the flange on each of the headlight washer units as shown. Ensure the washer unit is secured firmly (eg. with a table clamp) before cutting.

**TOOLS REQUIRED**

- Safety glasses
- Air Hacksaw  
or  
Oscillating Multi Tool  
or  
Angle Grinder  
or  
Jigsaw

**FASTENERS**





99. Slide the B-1465 headlight washer retainer brackets onto the main shaft of the headlight washer units.

There is a left-hand and right-hand version of the retainer bracket. See image above of the angled edge used for identifying.

**TOOLS REQUIRED**

**FASTENERS**

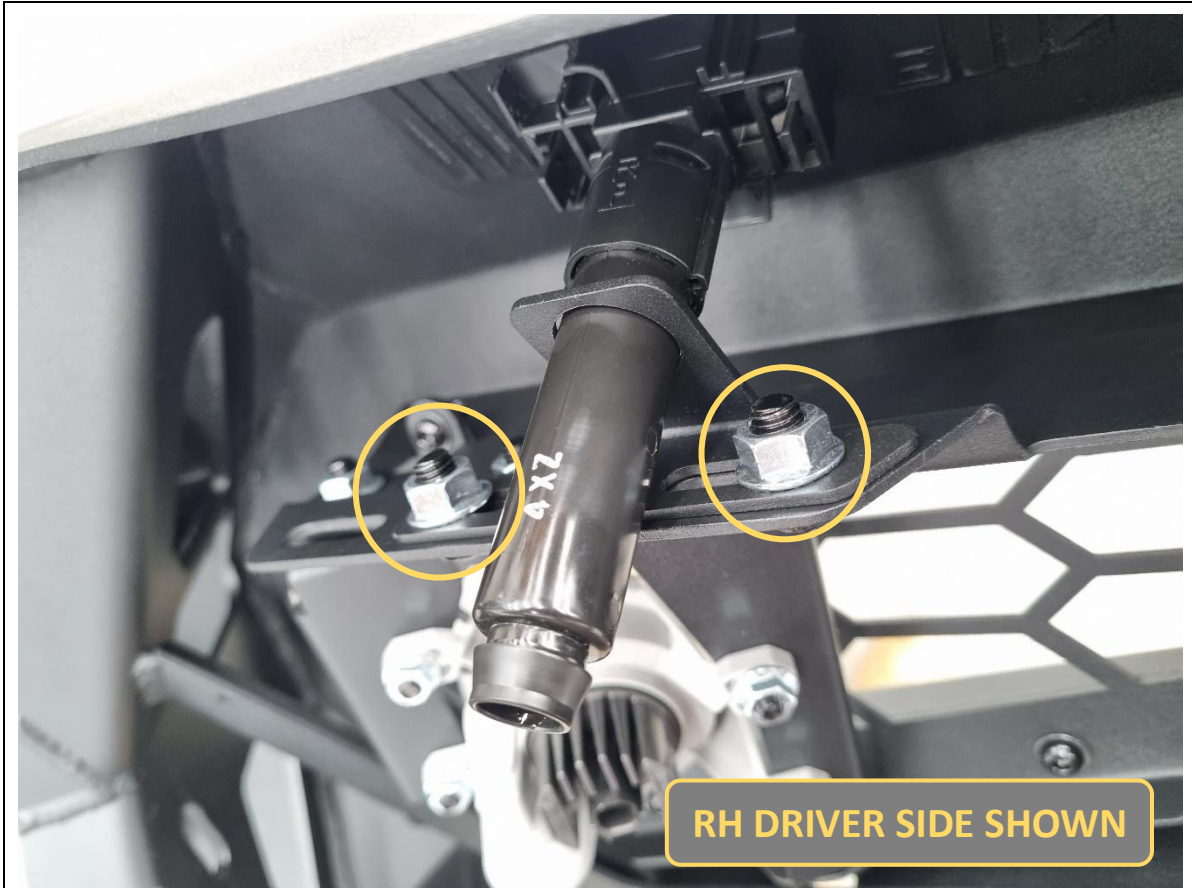

<p>100. Clip the headlight washer unit into the installed headlight washer holder inside the bull bar.</p> <p>101. Secure the retaining bracket to the wing mesh with 2x M8x16 black button head bolts, black washers and flange nuts.</p> <p>If fitting with cube lights, you may need to use the same bolt for securing both cube light and headlight washer retaining bracket.</p>	<p><b>TOOLS REQUIRED</b></p> <p>5mm hex/Allen key</p>
<p>102. Repeat for other side.</p>	<p><b>FASTENERS</b></p> <p>4x M8x16 black button head bolt 4x M8 black flat washer 4x M8 flange nut</p>

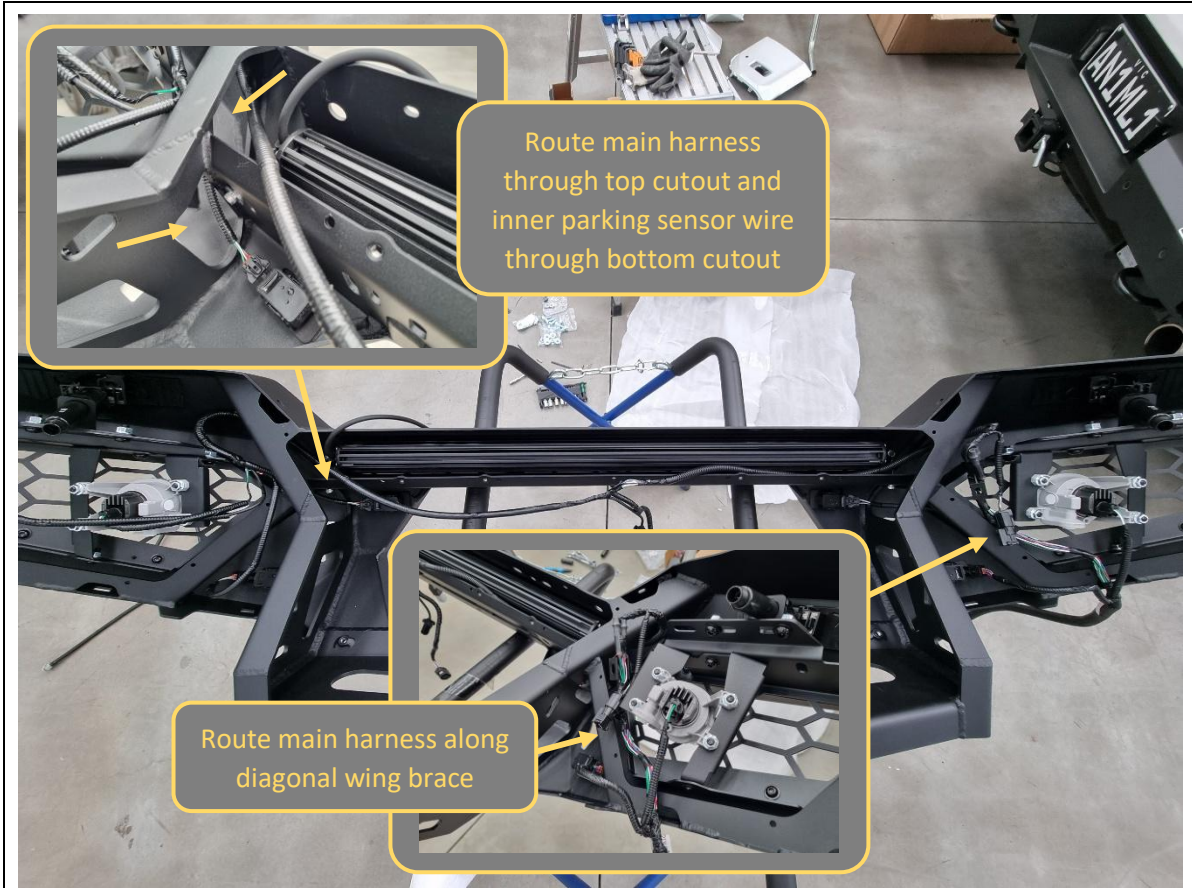

103. Route the bumper wiring harness through the bar and connect the fog lights and parking sensors.

**TOOLS REQUIRED**

**FASTENERS**





104. Connect the washer hose back to the headlight washer units. Leave the washer hose sitting on the outside of the bull bar, do not route through the cutouts inside.

**TOOLS REQUIRED**

**FASTENERS**



105. Secure the bumper wiring harness and washer hose to the provided holes in the bull bar using cable ties.

Leave the camera and radar wires hanging loose out of the centre section (see inset photo).

Take care not to clamp the washer hose too tight or else it will restrict/cut off fluid flow.

**TOOLS REQUIRED**

Cable ties (not supplied)

Side cutters

**FASTENERS**



<p>106. Fit the pair of pan braces to the back of the light bar mounting area in the bull bar.</p> <p>107. Secure the bottom of each pan brace to the embedded nuts in the bull bar with 2x M6x16 black button head bolts and black washers.</p> <p>108. If fitting to the VX/Kakadu spec with the 'luxury' grille, secure the top of each pan brace now with 2x M6x16 black button head bolts, black washers and flange nuts.</p> <p>For GX/GXL/Altitude, these bolts will be fitted after the next step.</p>	<p><b>TOOLS REQUIRED</b></p> <p>4mm hex/Allen key</p>
	<p><b>FASTENERS</b></p> <p>8x M6x16 black button head bolt 8x M6 black flat washer 4x M6 flange nut</p>





- 109. **GX/GXL/Altitude only.** Fit the B-1432 grille infill to the bull bar. The little tabs sit on the inside of the bull bar and over the pan braces.
- 110. **GX/GXL/Altitude only.** Secure the infill with 6x M6x16 black button head bolts, black washers and flange nuts. 4x of the bolts go through the pan brace holes, and the remaining 2x at the far outer ends of the infill.

**TOOLS REQUIRED**

4mm hex/Allen key

**FASTENERS**

6x M6x16 black button head bolt  
6x M6 black flat washer  
6x M6 flange nut



**RH DRIVER SIDE SHOWN**

<p>111. Fit the supplied 2x lengths of pinch weld rubber to the top edge of the bull bar wings. Trim off any excess around the centre section.</p>	<p><b>TOOLS REQUIRED</b></p> <p>Side cutters</p>
	<p><b>FASTENERS</b></p>



<p>112. <b>Toro only.</b> If required, fit the supplied antenna mounting brackets to the back of the bar, and secure with 2x M8x20 black button head bolts and black washers, each.</p> <p>113. <b>Toro only.</b> Else fit the 2x M8x20 black button head bolts and black washers to the back of each bullbar upright, to protect nut threads in bar for future use.</p>	<p><b>TOOLS REQUIRED</b></p> <p>5mm hex/Allen key</p>
	<p><b>FASTENERS</b></p> <p>4x M8x20 black button head bolt 4x M8 black flat washer</p>



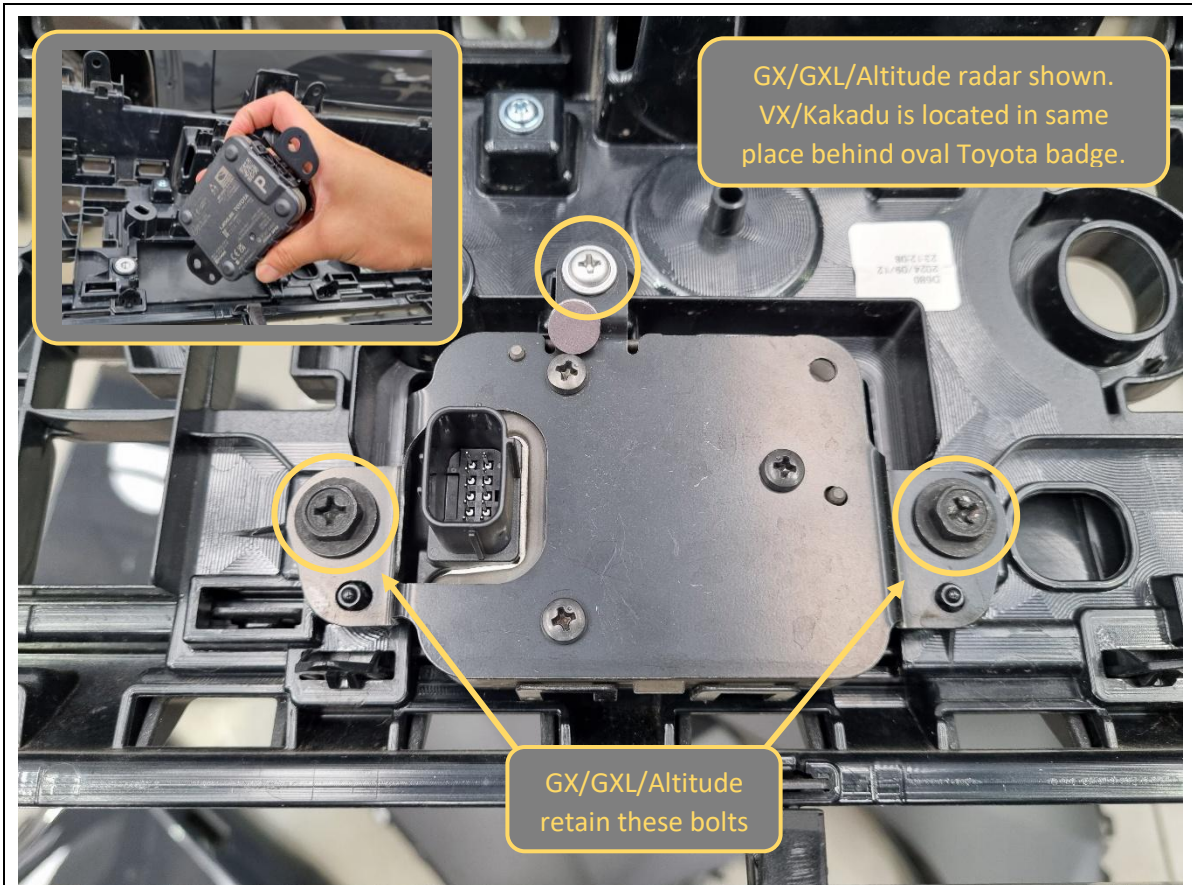

<p>The radar and camera need to be removed before the grille goes back on the car.</p> <p>114. Remove 2x 10mm hex bolts and 1x Phillips head screw holding the radar to grille.</p> <p>115. Set the radar aside in a safe place. Take care not to drop or damage the radar.</p>	<p><b>TOOLS REQUIRED</b></p> <p>10mm socket/spanner</p> <p>Phillips head screwdriver</p>
<p>116. <b>GX/GXL/Altitude only.</b> Retain the 2x 10mm hex bolts.</p>	<p><b>FASTENERS</b></p> <p>2x 10mm hex bolts</p> <p>1x Phillips head screw</p>

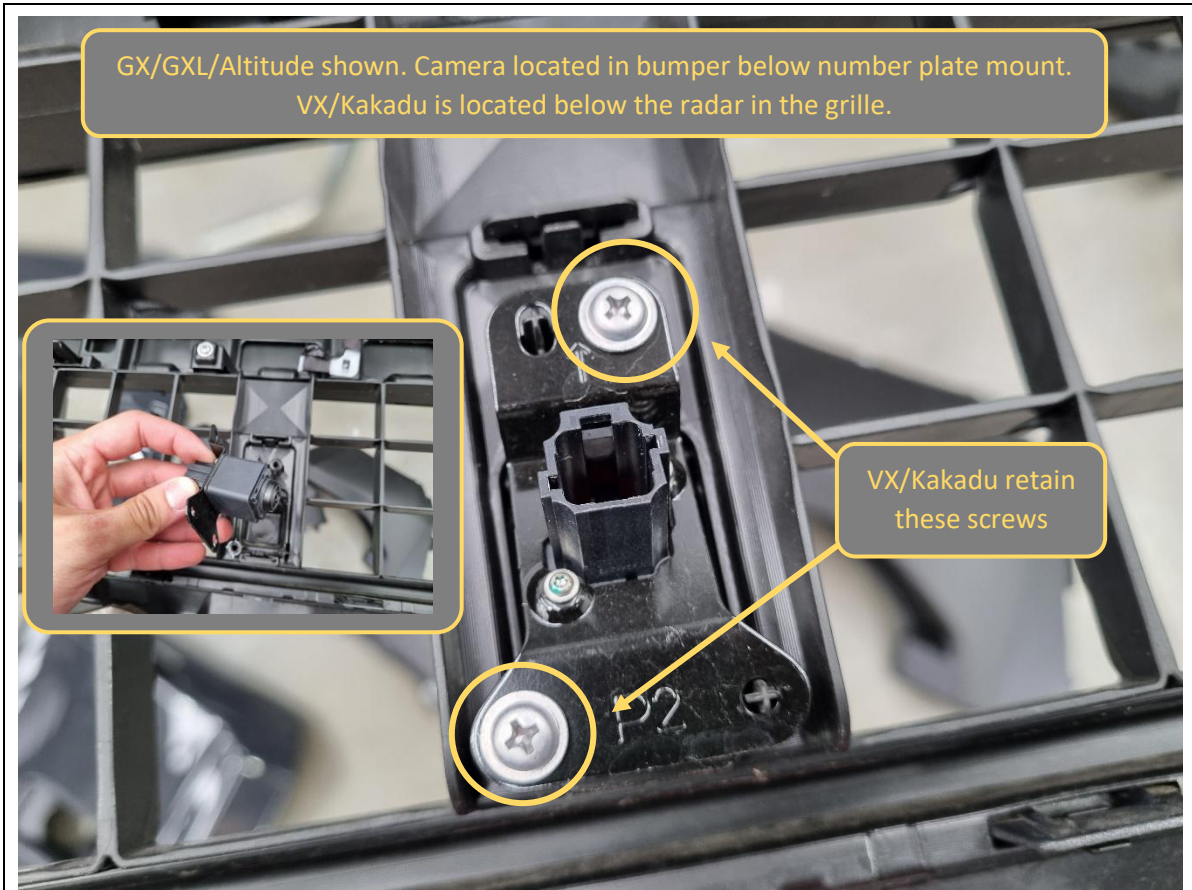

- 117. Remove 2x Phillips head screws holding the camera to the grille (VX/Kakadu) or bumper (GX/GXL/Altitude).
- 118. Set the camera aside in a safe place. Take care not to drop or damage the camera.
- 119. **VX/Kakadu only.** Retain the 2x Phillips head screws.

**TOOLS REQUIRED**

Phillips head screwdriver

**FASTENERS**

2x Phillips head screws



**LH PASSENGER SIDE SHOWN**

**VX/KAKADU ONLY**



120. There are two different grille variants. For VX/Kakadu, refer to the steps below. GX/GXL/Altitude skip to Step 127.

121. **VX/Kakadu only.** Remove 3x Phillips head screws holding each plastic grille side retainer. Retain screws for re-assembly.

**TOOLS REQUIRED**

Phillips head screwdriver

**FASTENERS**

6x Phillips head screws

Retain for re-assembly



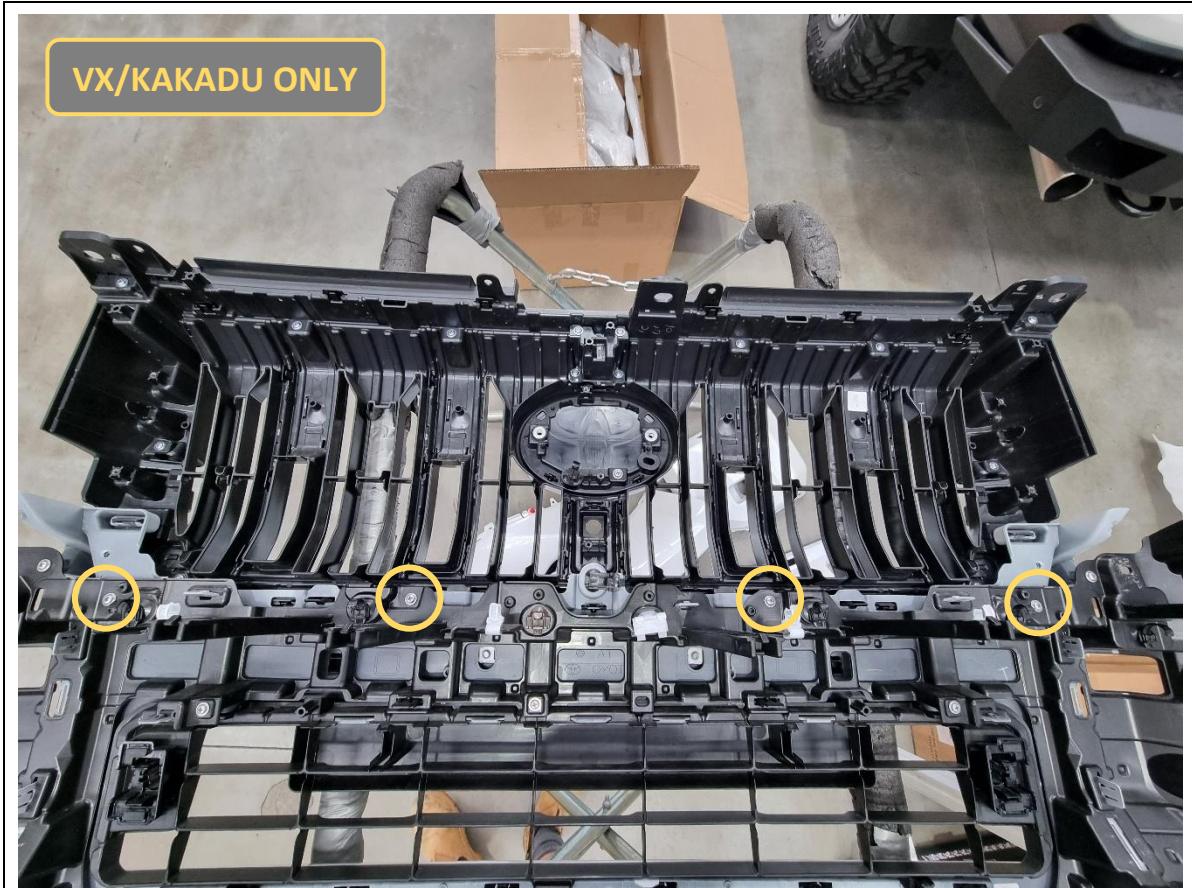

122. **VX/Kakadu only.** Remove 4x Phillips head screws holding the bottom of the grille to the bumper.

**TOOLS REQUIRED**

Phillips head screwdriver

**FASTENERS**

4x Phillips head screws

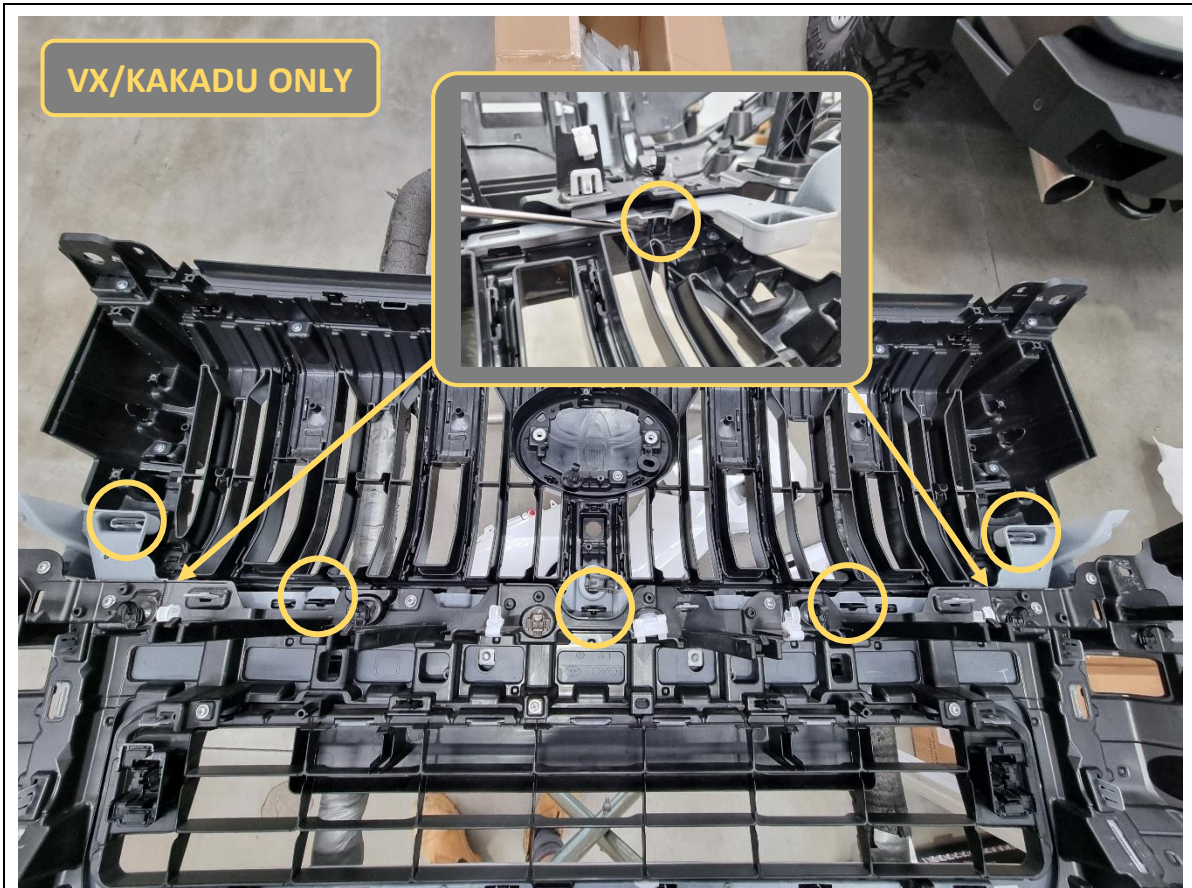

123. **VX/Kakadu only.** Using a flat blade screwdriver or trim tool, release 7x tabs/clips holding the grille to the bumper.

There are 2x hidden tabs (see inset photo). These can be accessed after the main 5x are released and the grille is separated apart slightly.

**TOOLS REQUIRED**

Flat blade screwdriver  
or  
Trim tool

**FASTENERS**



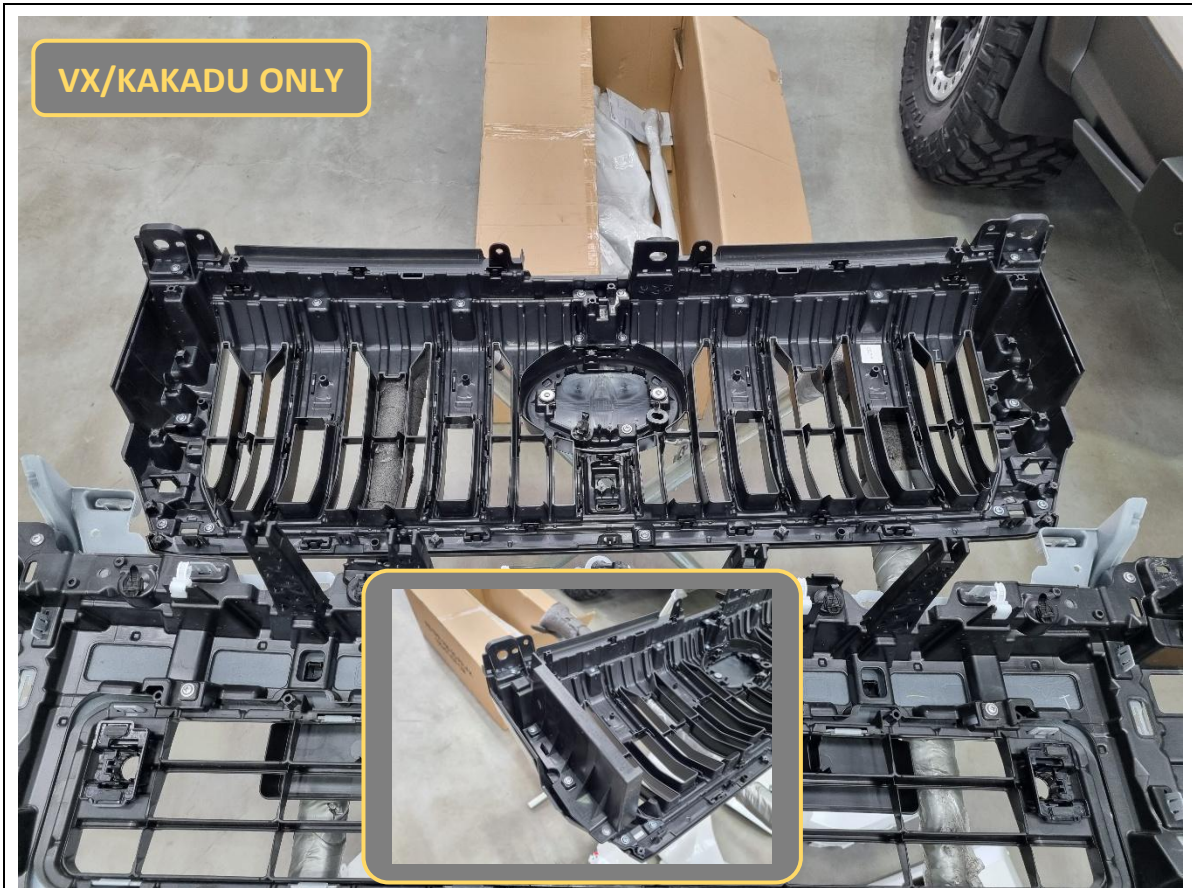

124. **VX/Kakadu only.** Fully separate the grille from the bumper. The bumper may now be discarded.

125. **VX/Kakadu only.** Re-fit both grille side retainers back to the grille with Phillips head screws.

**TOOLS REQUIRED**

Phillips head screwdriver

**FASTENERS**

6x Phillips head screws



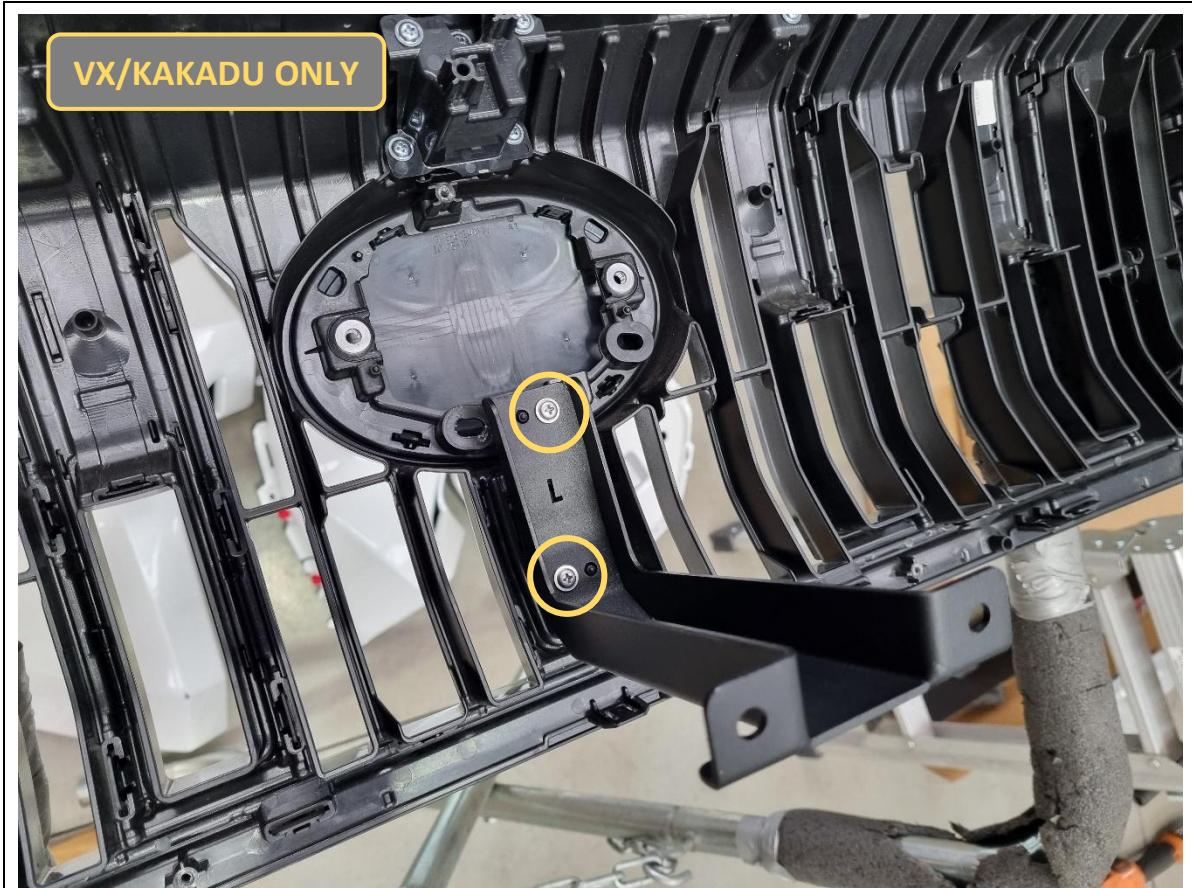

126. **VX/Kakadu only.** Fit the B-1469 grille support to the back of the grille, where the camera was mounted. Re-use the 2x Phillips head screws from the camera.

The VX/Kakadu 'luxury' grille support can be identified with the 'L' cutout in the bracket.

**TOOLS REQUIRED**

Phillips head screwdriver

**FASTENERS**

2x Phillips head screws

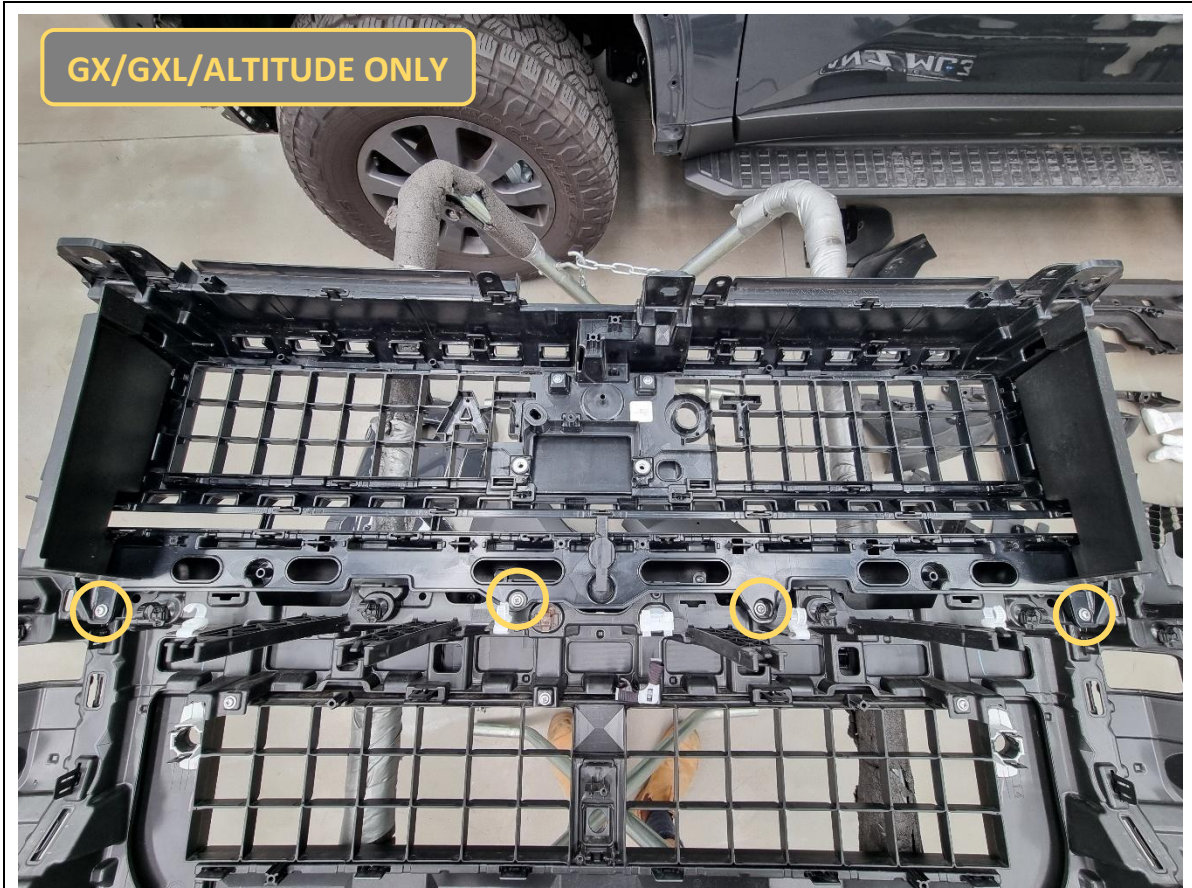

<p>The following steps apply to GX/GXL/Altitude grille removal only. VX/Kakadu skip to Step 139.</p> <p>127. <b>GX/GXL/Altitude only.</b> Remove 4x Phillips head screws holding the grille to the bumper.</p>	<p><b>TOOLS REQUIRED</b></p> <p>Phillips head screwdriver</p>
	<p><b>FASTENERS</b></p> <p>4x Phillips head screws</p>



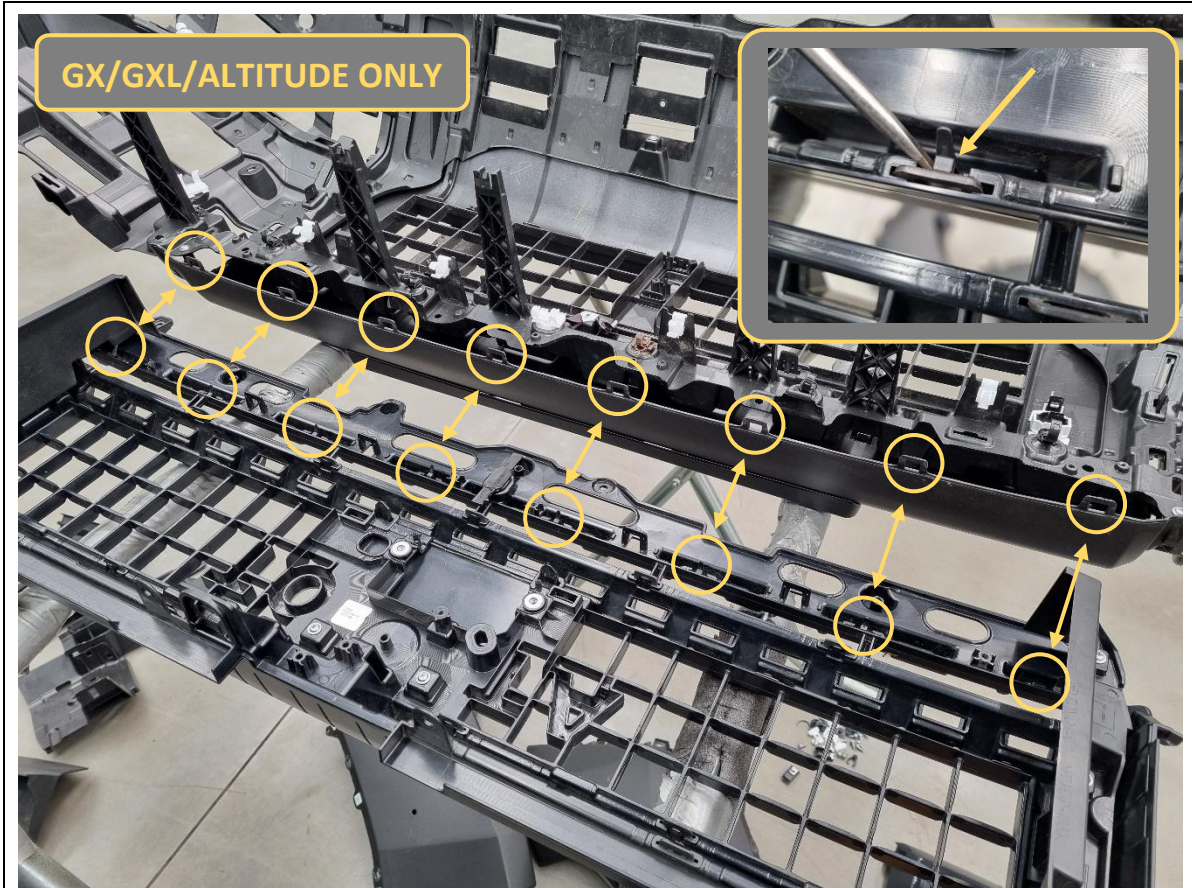

128. **GX/GXL/Altitude only.** Using a flat blade screwdriver or trim tool, release 8x tabs/clips holding the grille to the bumper. Fully separate the grille from the bumper. The bumper may now be discarded.

**TOOLS REQUIRED**

Flat blade screwdriver  
or  
Trim tool

**FASTENERS**





LH PASSENGER SIDE SHOWN

GX/GXL/ALTITUDE ONLY

129. **GX/GXL/Altitude.** Remove 3x Phillips head screws holding each plastic grille side retainer. Retain screws for re-assembly.

**TOOLS REQUIRED**

Phillips head screwdriver

**FASTENERS**

6x Phillips head screws

Retain for re-assembly



<p>130. <b>GX/GXL/Altitude only.</b> The lower portion of the grille needs to be cut off. Mark out a cut line as shown. It will be flush with the bottom of the main grille section.</p>	<p><b>TOOLS REQUIRED</b></p> <p>Masking tape Marker pen</p>
	<p><b>FASTENERS</b></p>

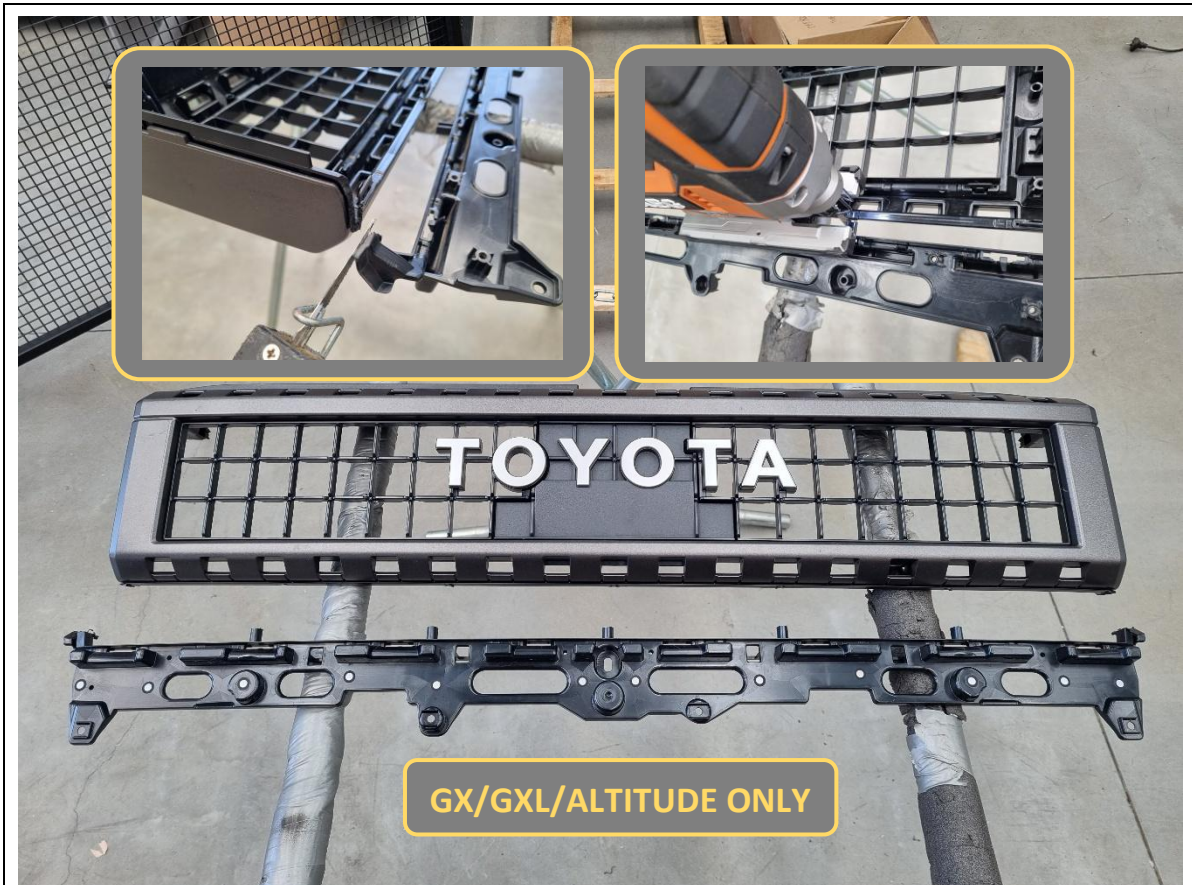

- 131. **GX/GXL/Altitude only.** Using an air hacksaw or similar cutting tool, cut the grille.
- 132. **GX/GXL/Altitude only.** Use a utility knife or similar tool to clean up the cut and remove any burrs.

**TOOLS REQUIRED**

- Safety glasses
- Air Hacksaw  
or  
Oscillating Multi Tool  
or  
Angle Grinder  
or  
Jigsaw
- Utility knife

**FASTENERS**



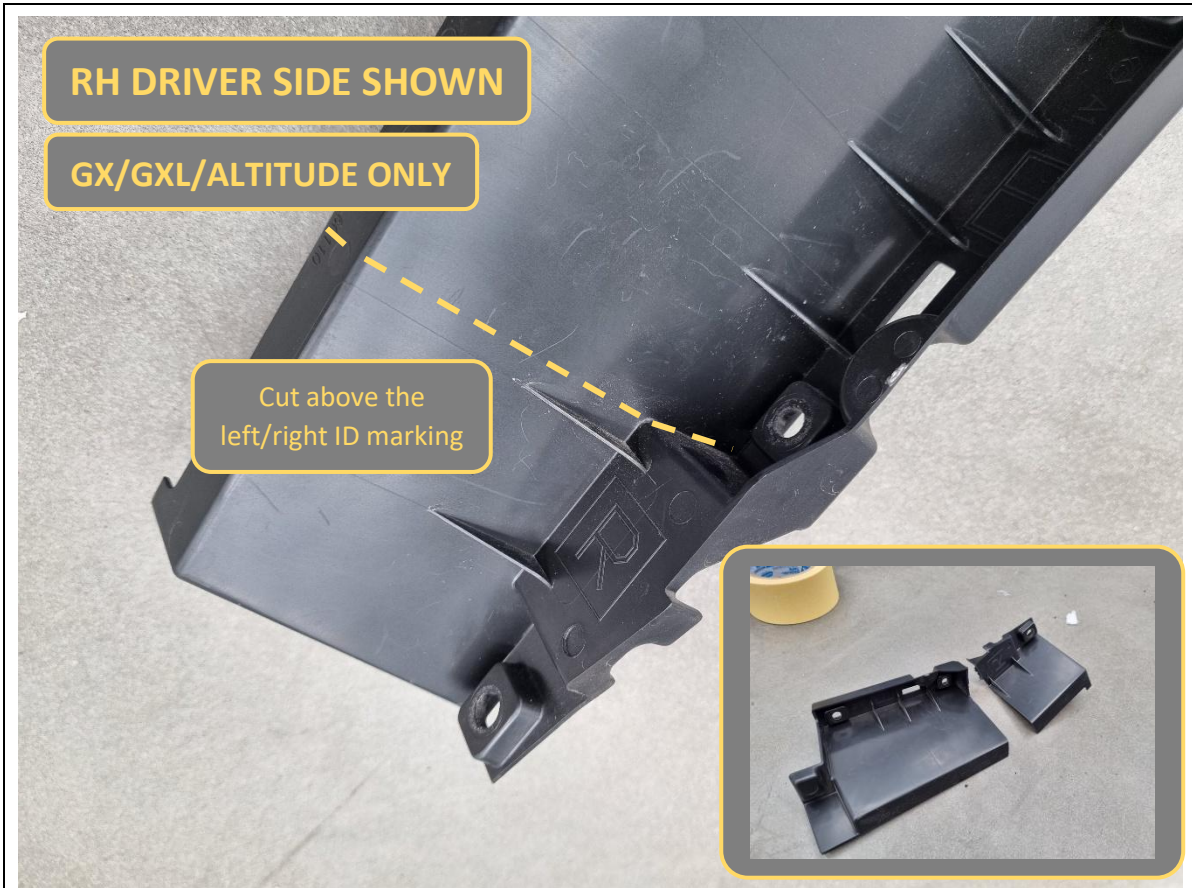

- 133. **GX/GXL/Altitude only.** The plastic grille side retainers also need to be cut to match the grille cut.
- 134. **GX/GXL/Altitude only.** Mark out a line as shown and cut using an air hacksaw or similar cutting tool. Discard the lower halves.
- 135. **GX/GXL/Altitude only.** Use a utility knife or similar tool to clean up the cut and remove any burrs.

**TOOLS REQUIRED**

- Safety glasses
- Air Hacksaw  
or  
Oscillating Multi Tool  
or  
Angle Grinder  
or  
Jigsaw
- Utility knife

**FASTENERS**



136. **GX/GXL/Altitude only.** Re-fit the plastic grille side retainers to the grille using 2x Phillips head screws, each.

**TOOLS REQUIRED**

Phillips head screwdriver

**FASTENERS**

4x Phillips head screws

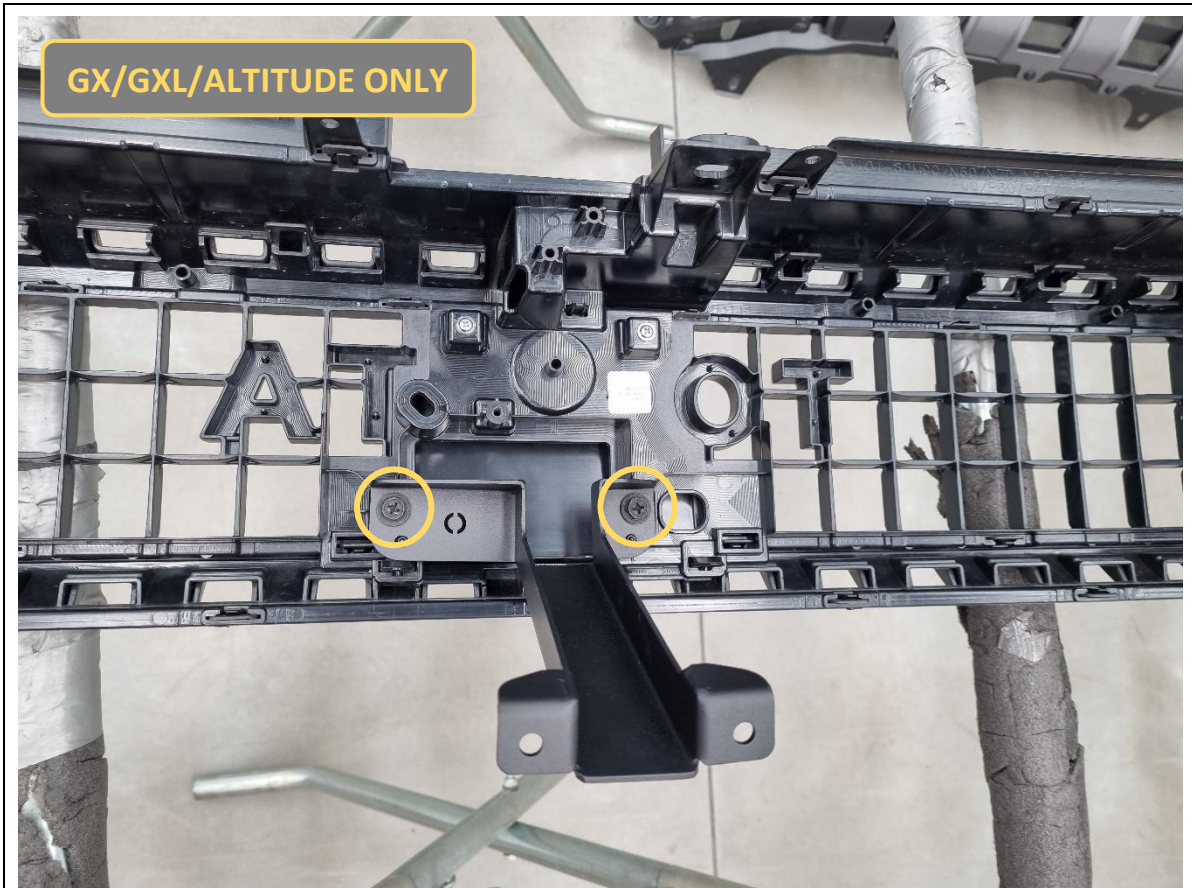

137. **GX/GXL/Altitude only.** Fit the B-1452 grille support to the back of the grille, where the radar was mounted. Re-use the 2x 10mm hex bolts from the radar.

The GX/GXL/Altitude 'offroad' grille support can be identified with the 'O' cutout in the bracket.

**TOOLS REQUIRED**

10mm socket/spanner

**FASTENERS**

2x 10mm hex bolt



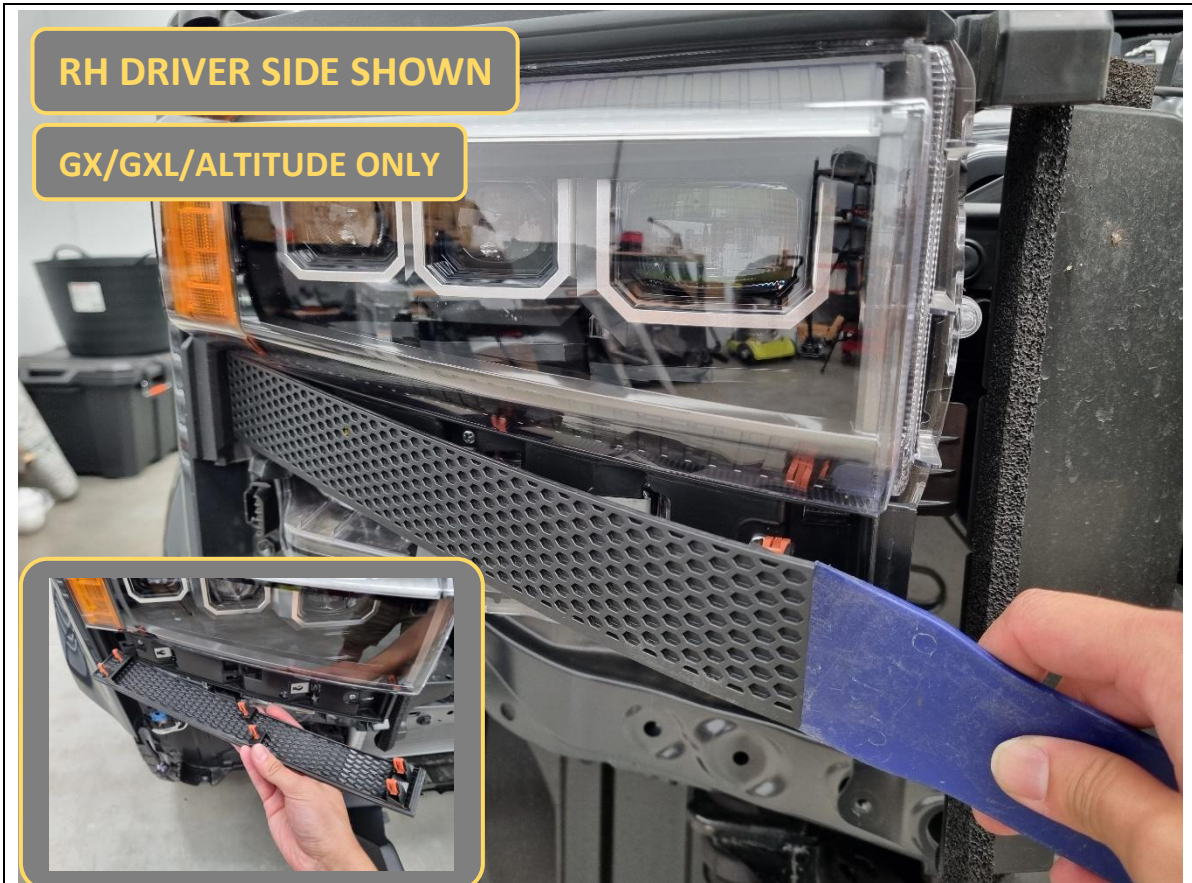

138. **GX/GXL/Altitude only.** Using a trim tool to assist, unclip the plastic under headlight trims, starting from the inner corner.

**TOOLS REQUIRED**

Trim tool

**FASTENERS**



139. Re-fit the grille back onto the vehicle.

140. **VX/Kakadu only.** Clip back in the under headlight trims removed earlier.

**TOOLS REQUIRED**

**FASTENERS**

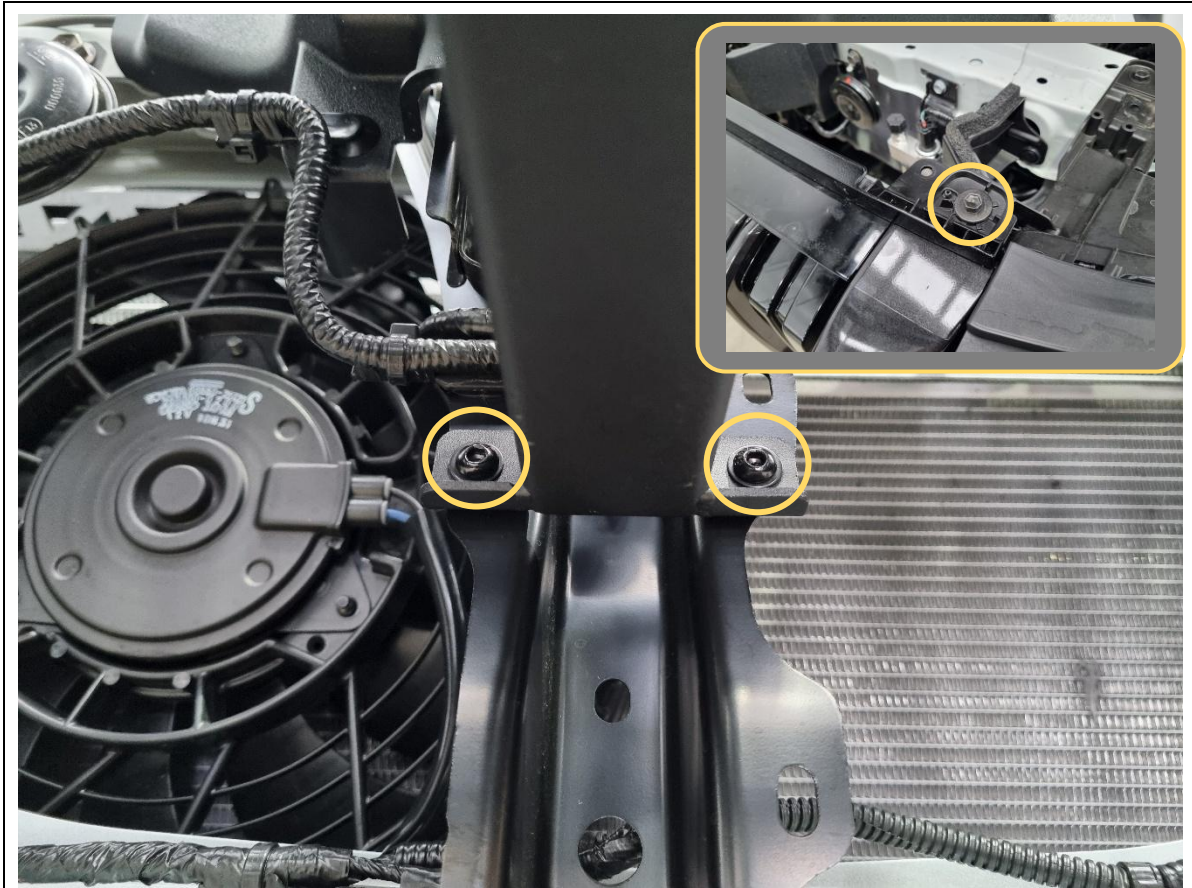

- 141. Re-secure the top of the grille using the original 3x 10mm hex bolts.
- 142. Secure the grille support to the body vertical cross member using 2x M6x16 black button head bolts, black washers and flange nuts.

**TOOLS REQUIRED**

- 10mm socket/spanner
- 4mm hex/Allen key

**FASTENERS**

- 3x 10mm hex bolt (retained)
- 2x M6x16 black button head bolt
- 2x M6 black flat washer
- 2x M6 flange nut





143. **VX/Kakadu only.** Using a deburring tool to remove the small notches in the camera opening on the grille.

144. **VX/Kakadu only.** Fit a supplied 16mm plastic blanking plug into the camera hole.

**TOOLS REQUIRED**

Deburring tool

**FASTENERS**

16mm plastic plug



<p>145. <b>GX/GXL/Altitude only.</b> Fit 2x cage nuts into the rectangle slots in each of the B-1468 headlight infill mounts (see inset photo). Use the cage nuts suited for thinner 2mm sheet metal.</p> <p>146. <b>GX/GXL/Altitude only.</b> Fit the B-1468 infill mounts under the headlights and secure each one with 2x M6x16 black button head bolts and black washers.</p>	<p><b>TOOLS REQUIRED</b></p> <p>Flat blade screwdriver</p> <p>4mm hex/Allen key</p>
	<p><b>FASTENERS</b></p> <p>4x M6 cage nut (to suit 2mm sheet metal)</p> <p>4x M6x16 black button head bolt</p> <p>4x M6 black flat washer</p>



147. **GX/GXL/Altitude only.** Clean the mounting surfaces of the supplied F-0034 headlight infills and the corresponding mounting surfaces of the B-1468 infill mounts with isopropyl alcohol or similar and let it dry.

148. **GX/GXL/Altitude only.** Use the remaining 3M Primer 94 ampule and apply primer to all the cleaned surfaces, both on the infills and mounts.

**TOOLS REQUIRED**

Isopropyl alcohol  
Rag

**FASTENERS**

1x 3M Primer 94





<p><b>Allow at least 5 minutes for the primer to chemically bond to the surfaces before applying tape.</b></p> <p>149. <b>GX/GXL/Altitude only.</b> Apply supplied 3M VHB tape from the Prado 250 tape kit to the headlight infills as shown.</p>	<p><b>TOOLS REQUIRED</b></p>
	<p><b>FASTENERS</b></p>

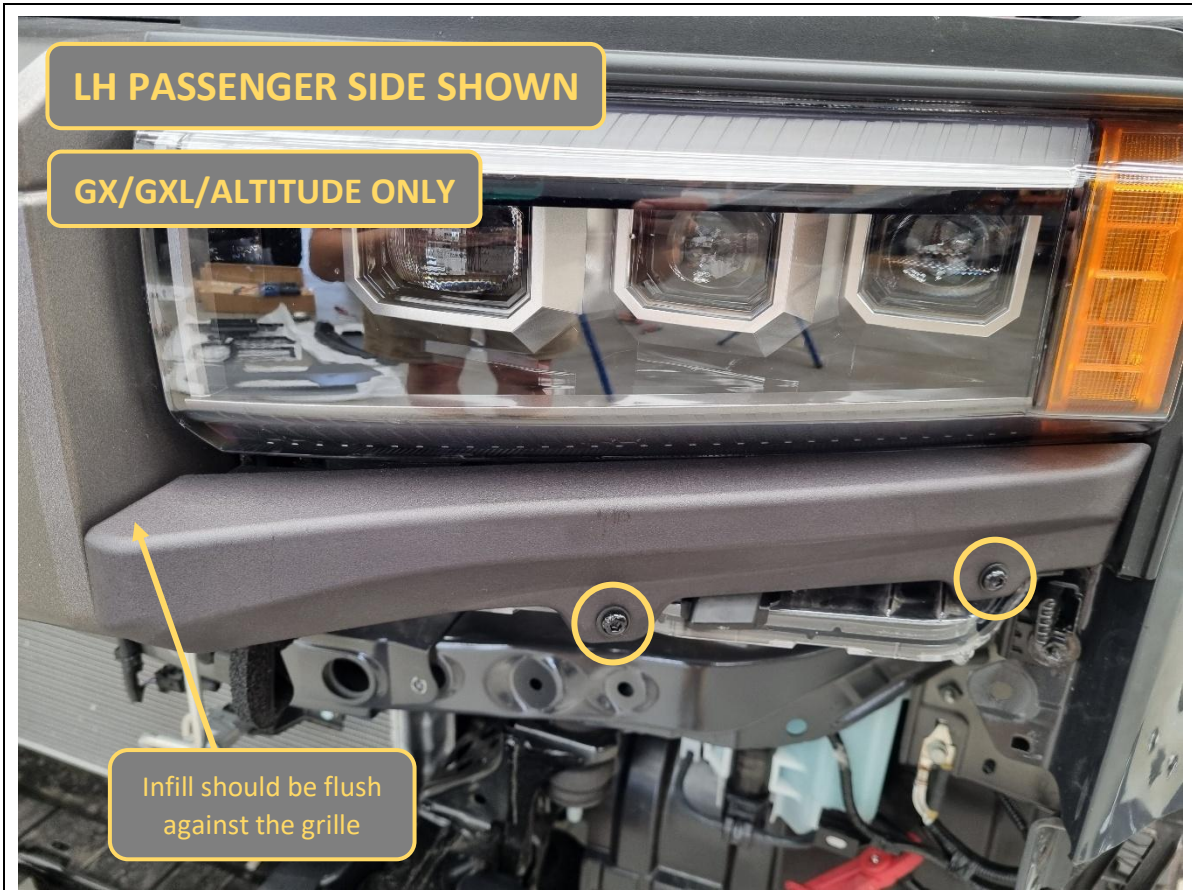

150. **GX/GXL/Altitude only.** Remove the backing film off the tape on the headlight infills (use utility knife to assist), then fit to their corresponding positions under the headlights, on the infill mounts.

151. **GX/GXL/Altitude only.** Secure each infill to the cage nuts in the infill mount with 2x M6x16 black button head bolts and black washers.

**TOOLS REQUIRED**

Utility knife

4mm hex/Allen key

**FASTENERS**

4x M6x16 black button head bolt  
4x M6 black flat washer

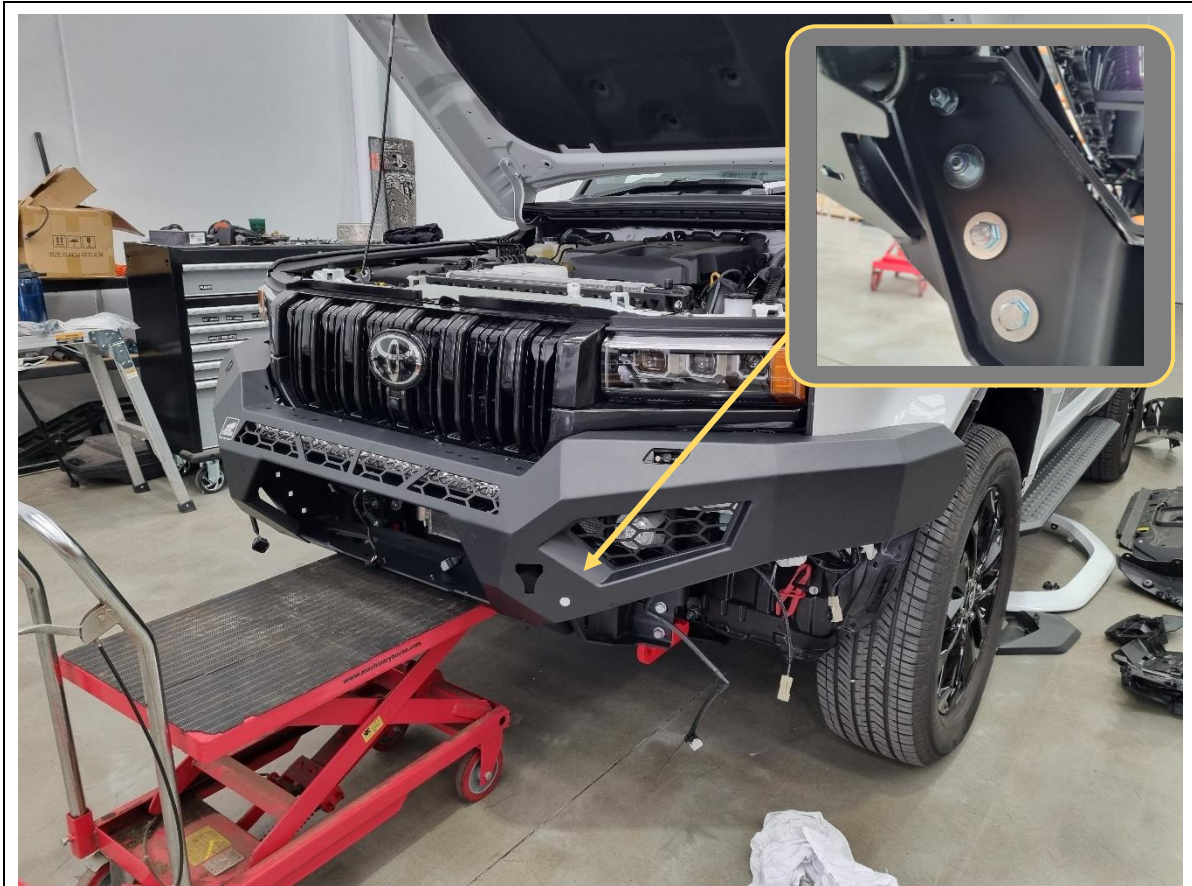

152. The bull bar is now finally ready to go onto the vehicle. With assistance, either from another person or a lifting trolley, lift the bar onto the mounts on the vehicle.

153. Secure the bar to the mounts with 8x M12x30 bolts, heavy-duty washers and Nyloc + flange nuts. Leave finger tight at this stage.

Note: Use a washer on both bolt and nut side for the Nyloc nut. 1x Nyloc required per side of the bar. 1x washer on the bolt side is all that is required with flange nuts.

**TOOLS REQUIRED**

Lifting trolley

**FASTENERS**

8x M12x30 hex bolt  
10x M12 heavy duty washer  
2x M12 Nyloc nut  
6x M12 flange nut





154. With assistance, from another person, align the bar with the edges of the vehicle. Adjust such that the clearances are neat, and the bar is symmetric left/right on the vehicle.

**Front view:** The bar should sit horizontally level. On GX/GXL/Altitude, the top edge of the grille infill should sit in line with the bottom edge of the grille. On VX/Kakadu, the top face of the bar should sit in line with the bottom lip of the grille.

**Side view:** The end of the bar wing should be in line with the wheel arch liner. (Ensure liner is pressed back up against the body, since the clips have been removed)

**Top view:** There should be around 15mm clearance between the bar and the grille, headlight infills and quarter panel.

155. Once happy with alignment, tighten all 8x M12 bolts.

**TOOLS REQUIRED**

Lifting Trolley

18/19mm socket/spanner

**FASTENERS**



- 156. Re-connect the bumper wiring harnesses on both LH and RH sides, as well as the headlight washer hose.
- 157. On the LH passenger side, unclip the harness off the body as shown in the inset photo and reposition the harness further inboard.
- 158. Neatly cable tie all the harnesses on both sides so that they are tucked inboard and inside the bull bar. Ensure there is a little bit of slack in the harness to allow for movement over bumps.

**TOOLS REQUIRED**

- Flat blade screwdriver  
or  
Trim tool
- Cable ties (not supplied)
- Side cutters

**FASTENERS**

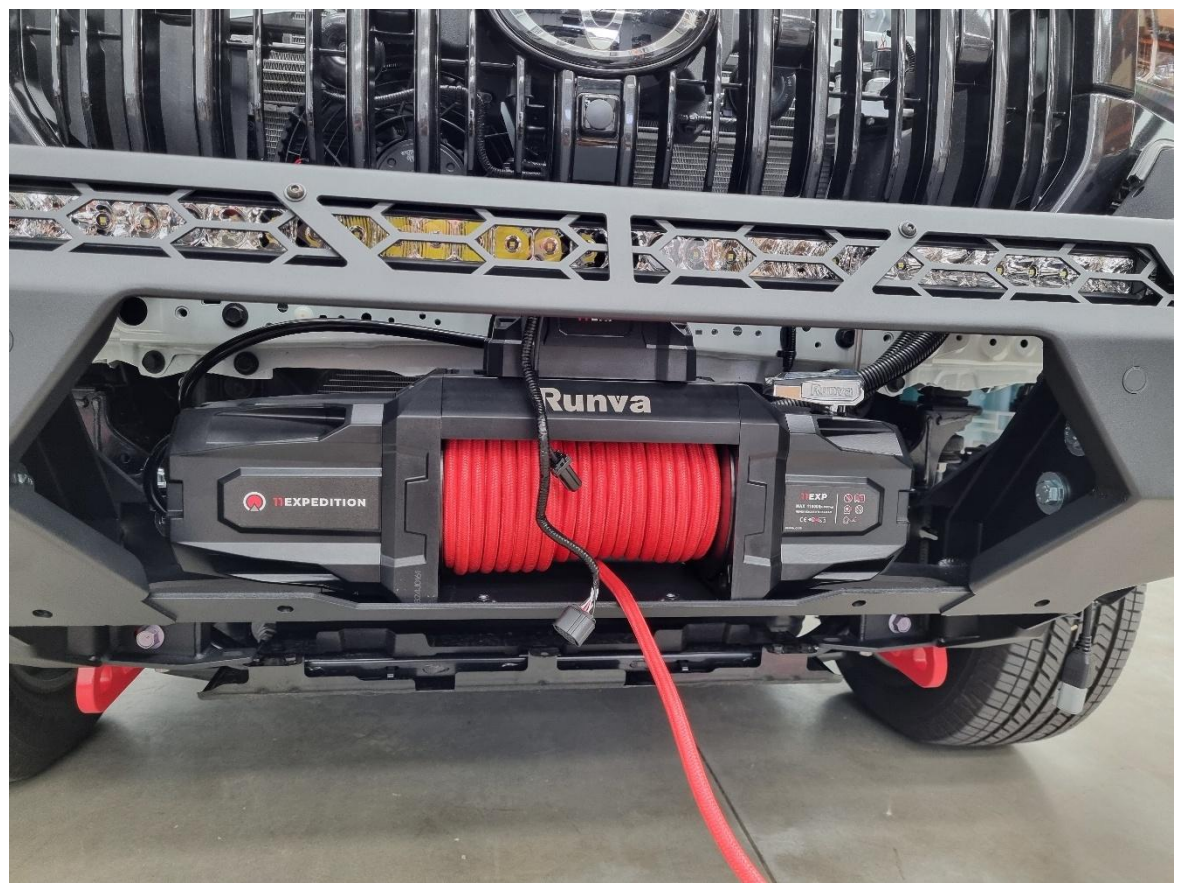

<p>159. If fitting a winch, do so now.</p> <p>Ensure the camera and radar harnesses do not get squished.</p> <p>This bar is designed to fit most low mount winches, in foot down configuration. WARN ZEON 12 is the largest winch confirmed to fit.</p>	<p><b>TOOLS REQUIRED</b></p> <p>Refer to instructions supplied by winch</p>
<p>Ensure clutch handle will be accessible through opening in front mesh panel. Refer to winch instructions regarding changing clutch handle location.</p>	<p><b>FASTENERS</b></p> <p>Supplied with winch</p>





<p>160. If fitting a winch, fit the hawse fairlead to the centre mesh now using M10 or 3/8" fasteners supplied with the winch. This bar is only compatible with hawse type fairleads.</p>	<p><b>TOOLS REQUIRED</b></p> <p>Refer to instructions supplied by winch</p>
	<p><b>FASTENERS</b></p> <p>Supplied with winch</p>

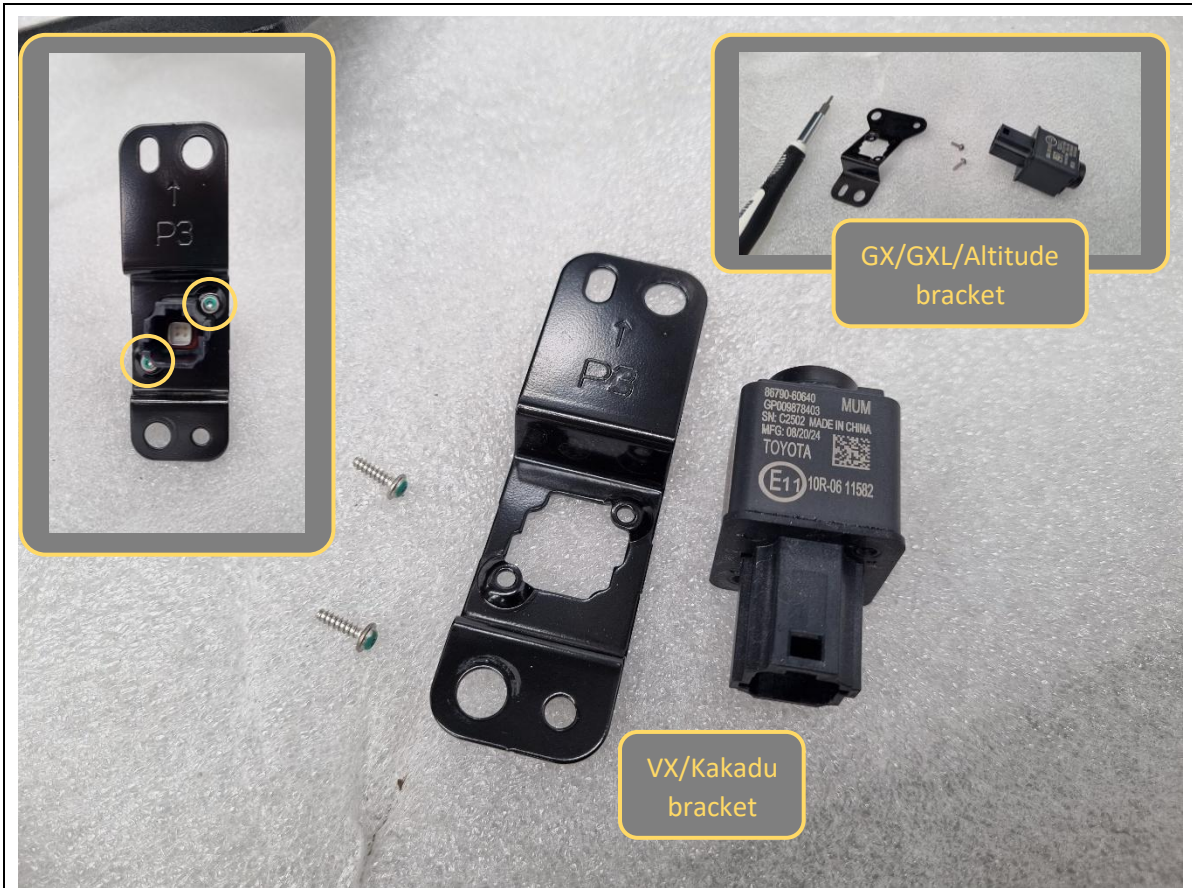

161. Remove the 2x T6 Torx screws holding the camera to its mounting bracket. Retain the screws.
162. Take note of the camera orientation before doing so, the labels should be facing up.

**TOOLS REQUIRED**

T6 Torx bit

**FASTENERS**

2x T6 Torx screws  
Retain for re-assembly

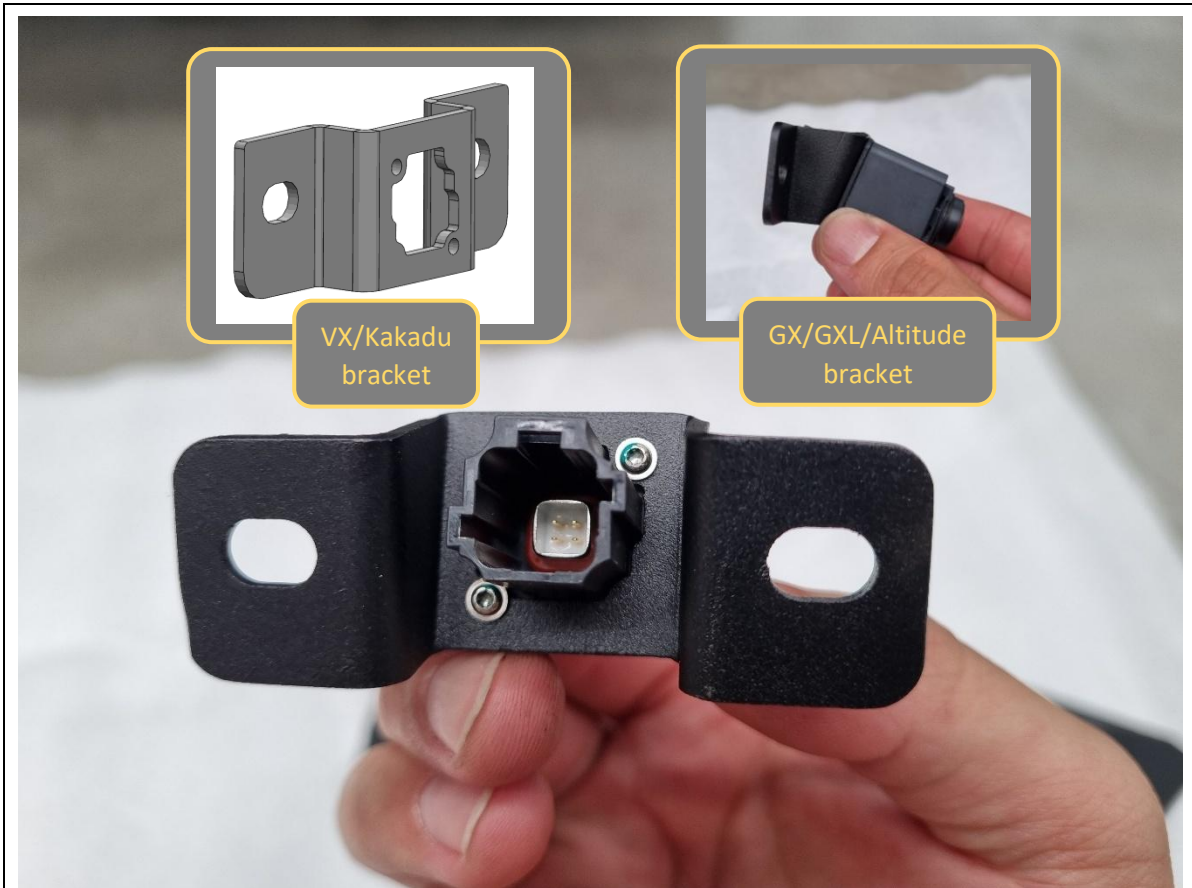

<p>163. Fit the camera to the supplied camera bracket and secure with the same T6 Torx screws. The cutout in the bracket is keyed, so the camera can only be fitted in one way.</p> <p>There are two different brackets supplied depending on vehicle trim level.</p> <p>For VX/Kakadu, use the B-1470 bracket. The camera will face straight forwards to match the original car.</p> <p>For GX/GXL/Altitude, use the B-1449 bracket. The camera will be angling downwards to match the original car.</p>	<p><b>TOOLS REQUIRED</b></p> <p>T6 Torx bit</p>
	<p><b>FASTENERS</b></p> <p>2x T6 Torx screws</p>





164. Fit the camera and bracket from the back of the centre mesh, and secure with 2x M6x16 black button head bolts, black washers and flange nuts.

**TOOLS REQUIRED**

4mm hex/Allen key

**FASTENERS**

2x M6x16 black button head bolt  
2x M6 black flat washer  
2x M6 flange nut



165. Fit the supplied camera housing to the outside of the centre mesh and camera, and secure from the back with 2x M6x16 black button head bolts and black washers.

There are two different camera housings supplied. Use the B-1471 straight housing with VX/Kakadu vehicles and the B-1450 angled housing with GX/GXL/Altitude vehicles.

**TOOLS REQUIRED**

4mm hex/Allen key

**FASTENERS**

2x M6x16 black button head bolt  
2x M6 black flat washer

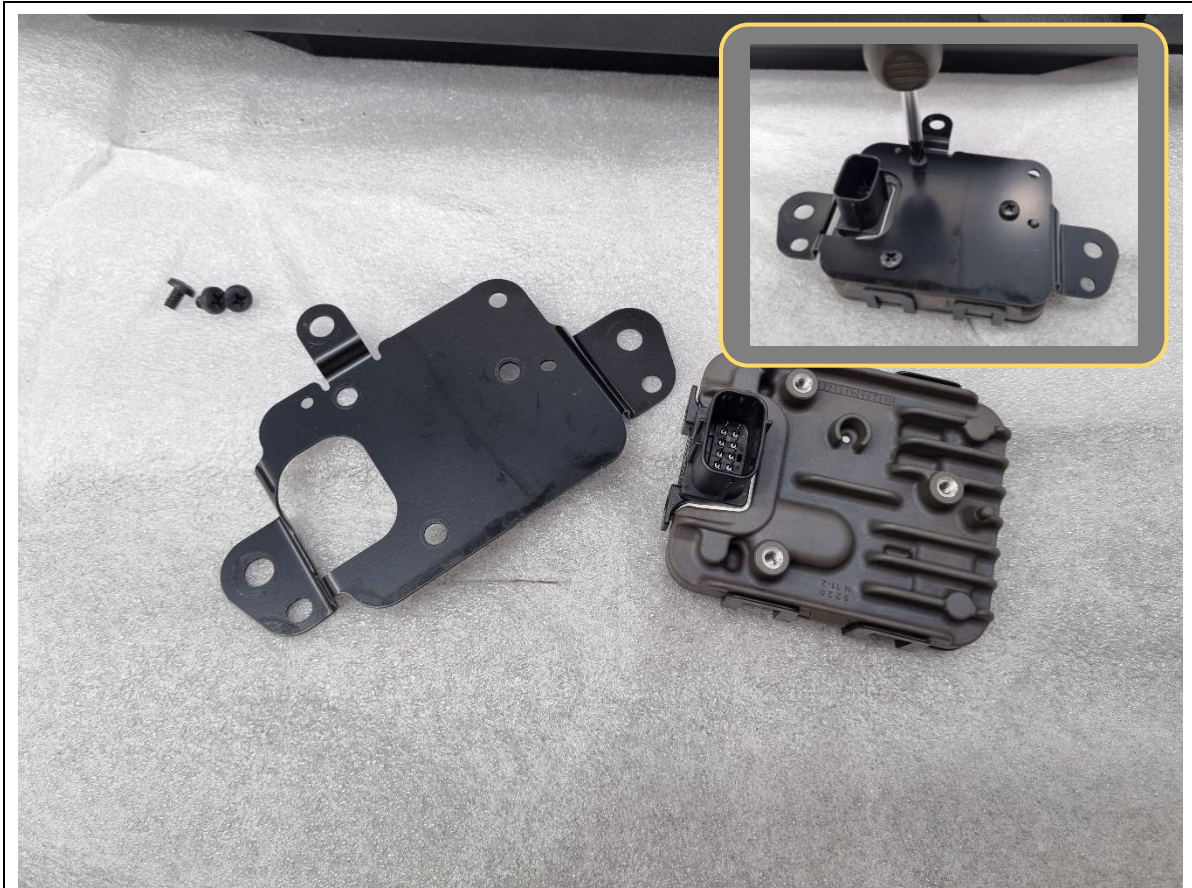

166. Separate the radar from its mounting bracket by removing 3x Phillips head screws. Retain the screws.

Take care not to strip the heads of the screws as they may be done up very tight.

**TOOLS REQUIRED**

Phillips head screwdriver

**FASTENERS**

3x Phillips head screws

Retain for re-assembly





167. Re-fit the radar to the supplied B-1447 relocation bracket and secure using the retained screws.

**TOOLS REQUIRED**

Phillips head screwdriver

**FASTENERS**

3x Phillips head screws

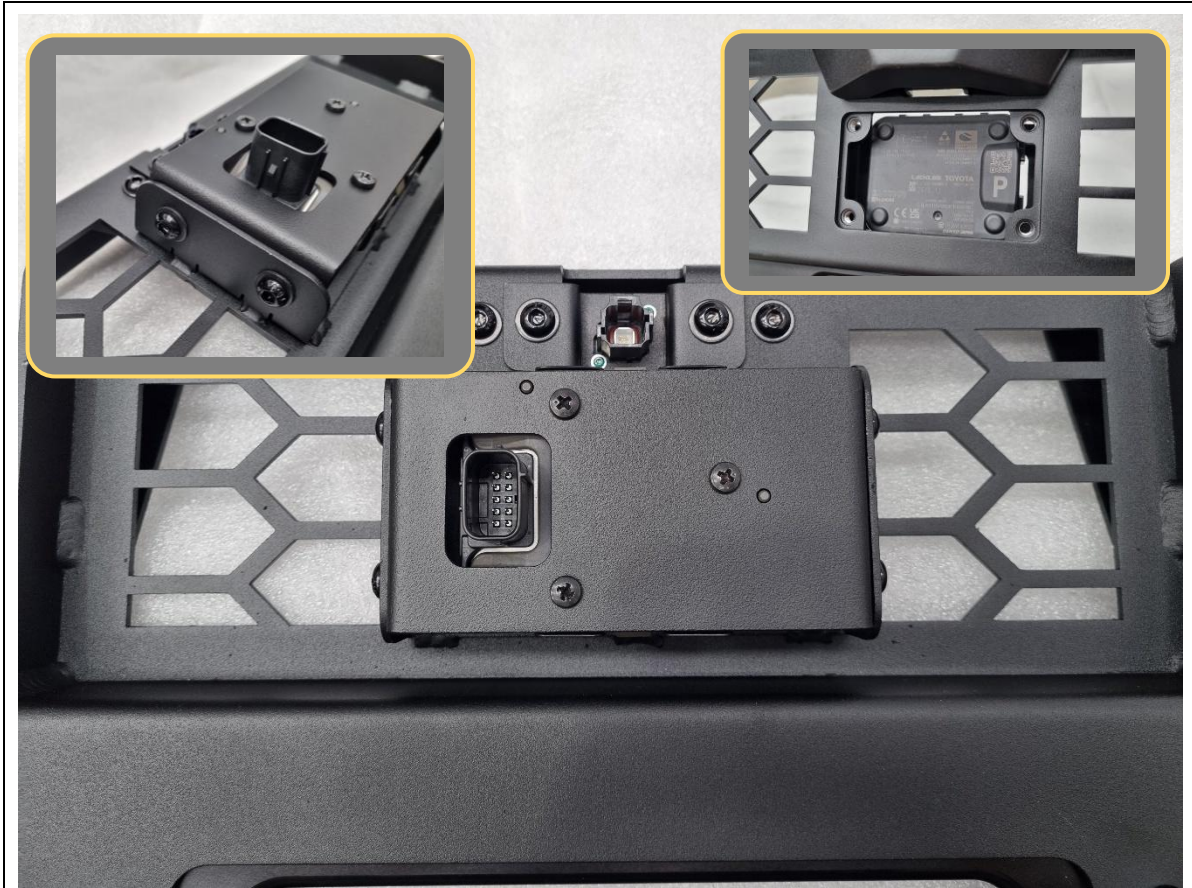

168. Fit the radar and relocation bracket to the back of the centre mesh, and loosely secure with 4x M6x16 black button head bolts and black washers.

The angle of the radar can be adjusted once it is installed onto the vehicle.

**TOOLS REQUIRED**

**FASTENERS**

4x M6x16 black button head bolt  
4x M6 black flat washer

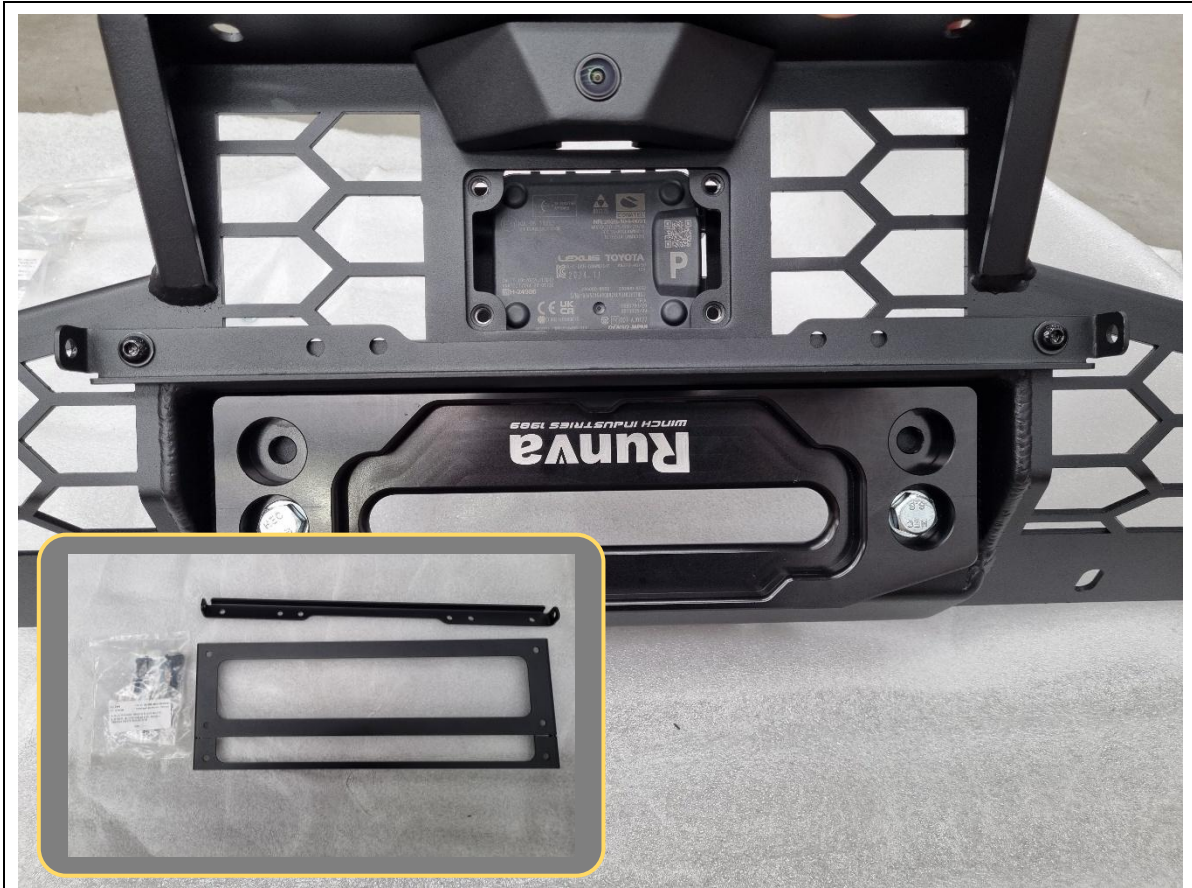

<p>Locate the number plate flip brackets and fastener kit.</p> <p>169. Fit the base bracket to the centre mesh and secure with 2x M6x16 black button head bolts, black washers and flange nuts.</p>	<p><b>TOOLS REQUIRED</b></p> <p>4mm hex/Allen key</p>
	<p><b>FASTENERS</b></p> <p>2x M6x16 black button head bolt 2x M6 black flat washer 2x M6 flange nut</p>



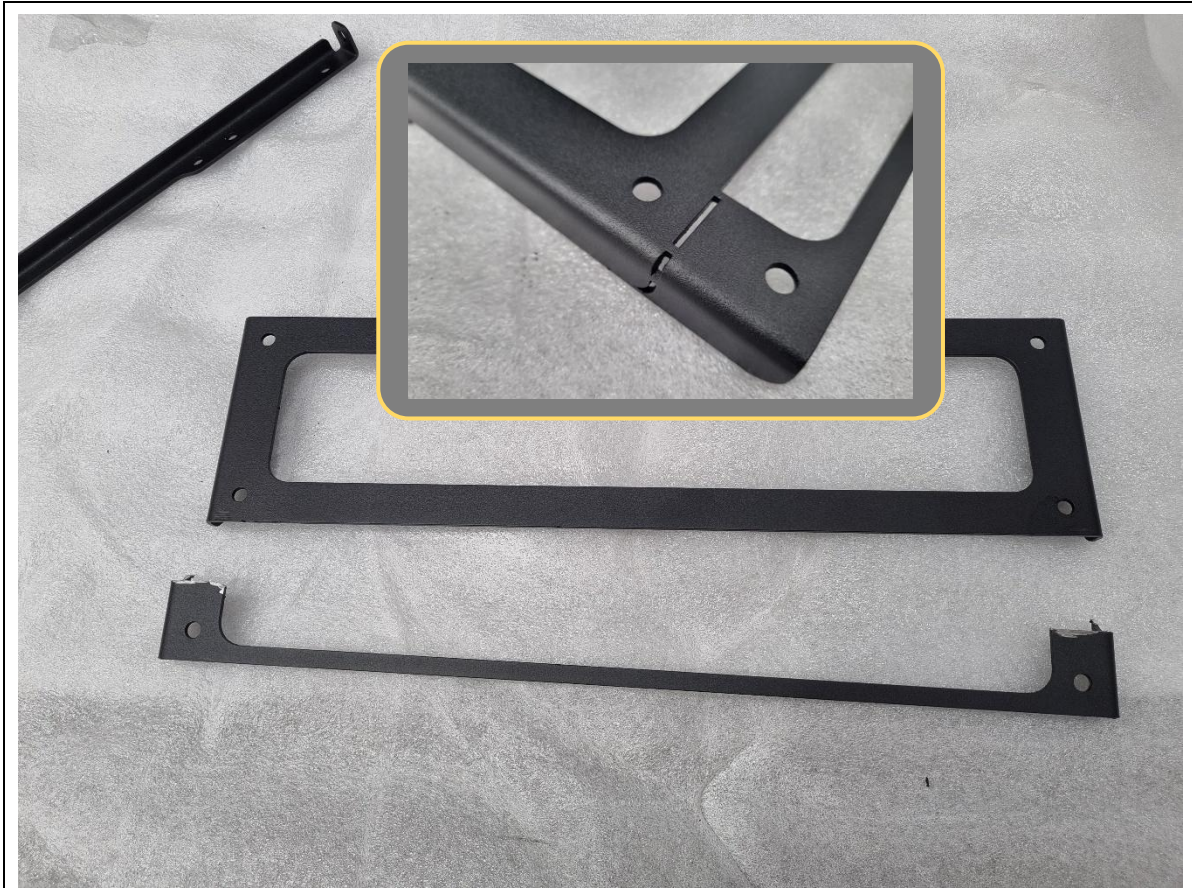

<p>The number plate flip bracket is designed to be compatible with both standard and slimline number plates.</p> <p>170. If fitting to a slimline plate, use an angle grinder to cut the bottom section of the bracket off along the laser cut grooves.</p> <p>171. Deburr the cut edges, then paint over to prevent rust.</p>	<p><b>TOOLS REQUIRED</b></p> <p>Angle grinder</p> <p>Deburring tool</p> <p>Black spray paint</p>
	<p><b>FASTENERS</b></p>

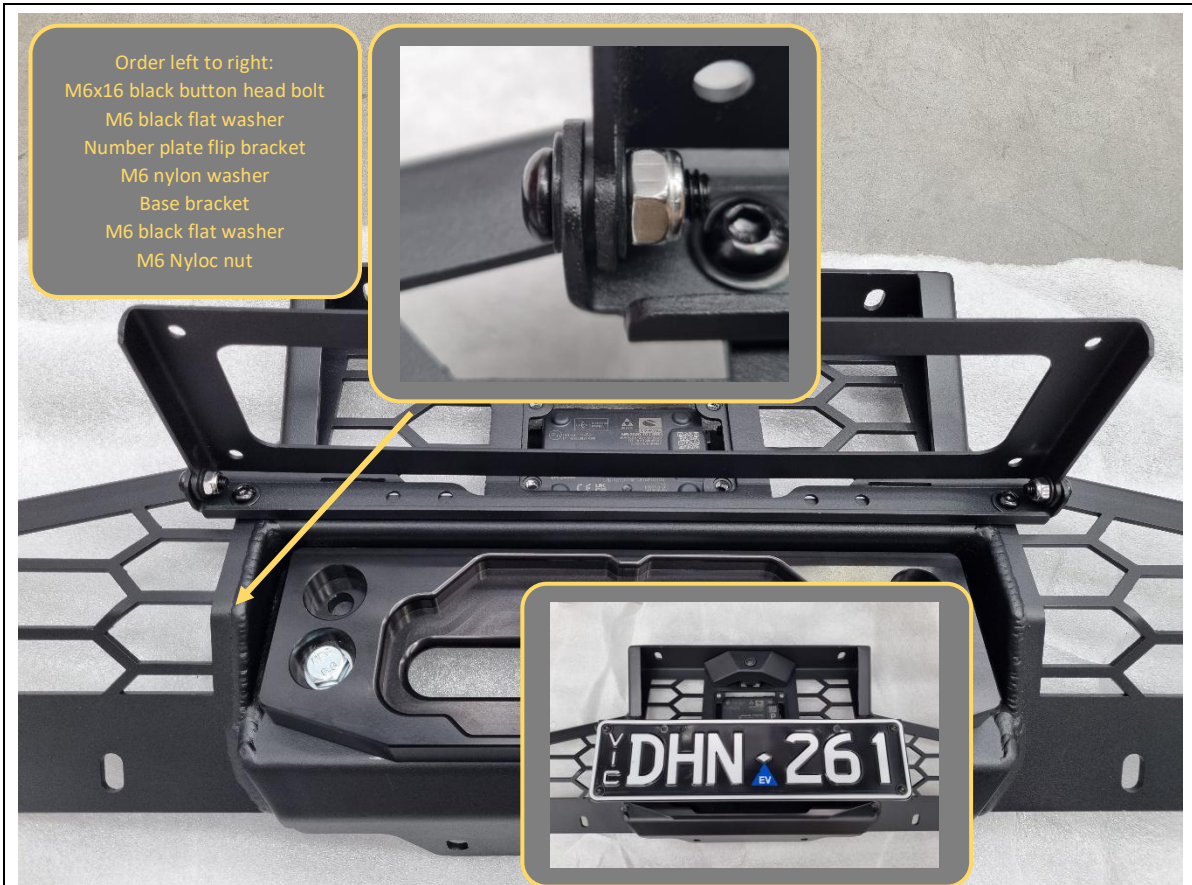

- 172. Fit number plate flip bracket to base bracket as shown above. Tighten bolts so that flip bracket can be moved by hand with some friction resistance.
- 173. Attach number plate to flip bracket using 4x M6x12 black button head bolts, black washers and flange nuts.

**TOOLS REQUIRED**

4mm hex/Allen key  
10mm spanner

**FASTENERS**

4x M6x12 black button head bolt  
2x M6x16 black button head bolt  
8x M6 black flat washer  
4x M6 flange nut  
2x M6 nylon washer  
2x M6 Nyloc nut

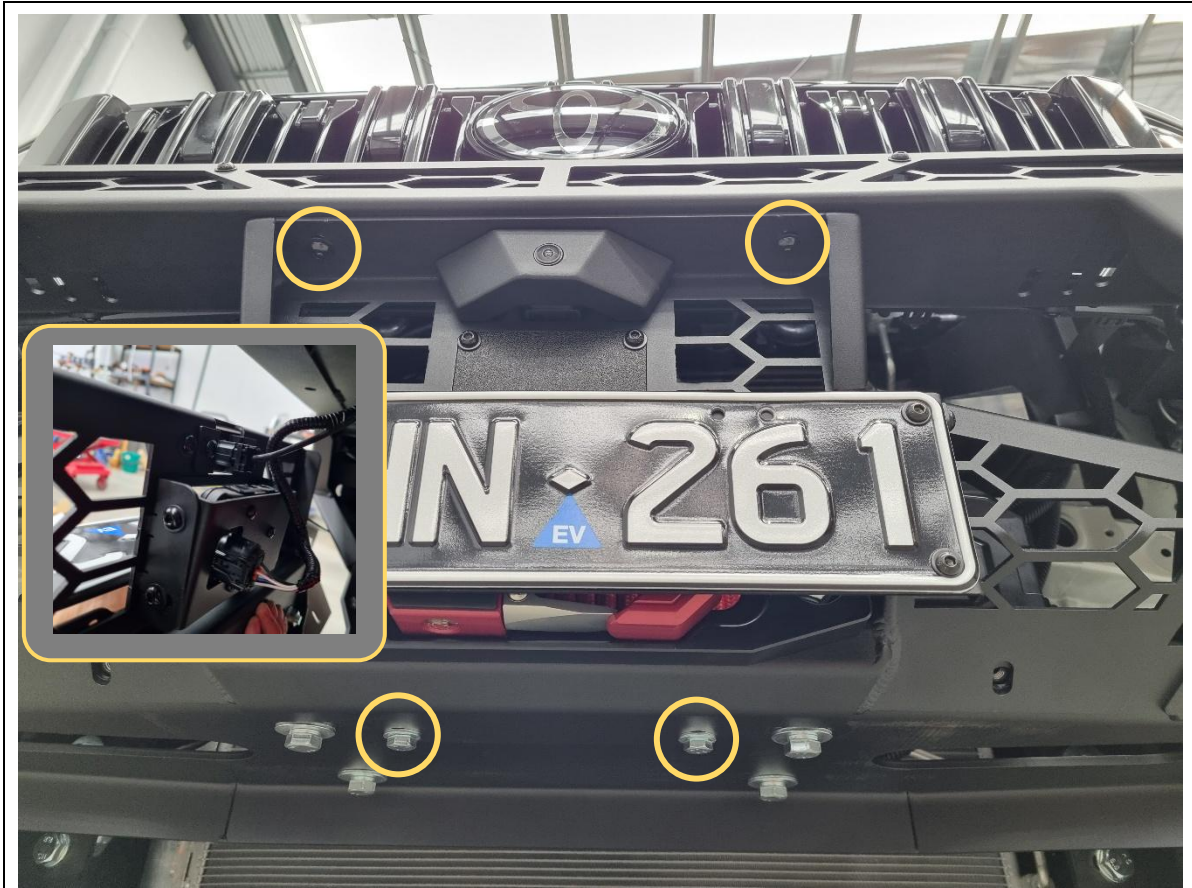

- 174. Present the centre mesh up to the centre opening of the bar. If a winch is fitted, feed the winch rope through the hawse fairlead and fit the winch hook.
- 175. Connect the radar and camera to the bumper harness.
- 176. Secure the centre mesh to the bar using 2x M8x16 black button head bolts + black washers (top), 2x M8x20 hex head bolts + heavy duty washers (bottom).

**TOOLS REQUIRED**

- 13mm socket/spanner
- 5mm hex/Allen key

**FASTENERS**

- 2x M8x16 black button head
- 2x M8 black flat washer
- 2x M8x20 hex head
- 2x M8 heavy duty washer



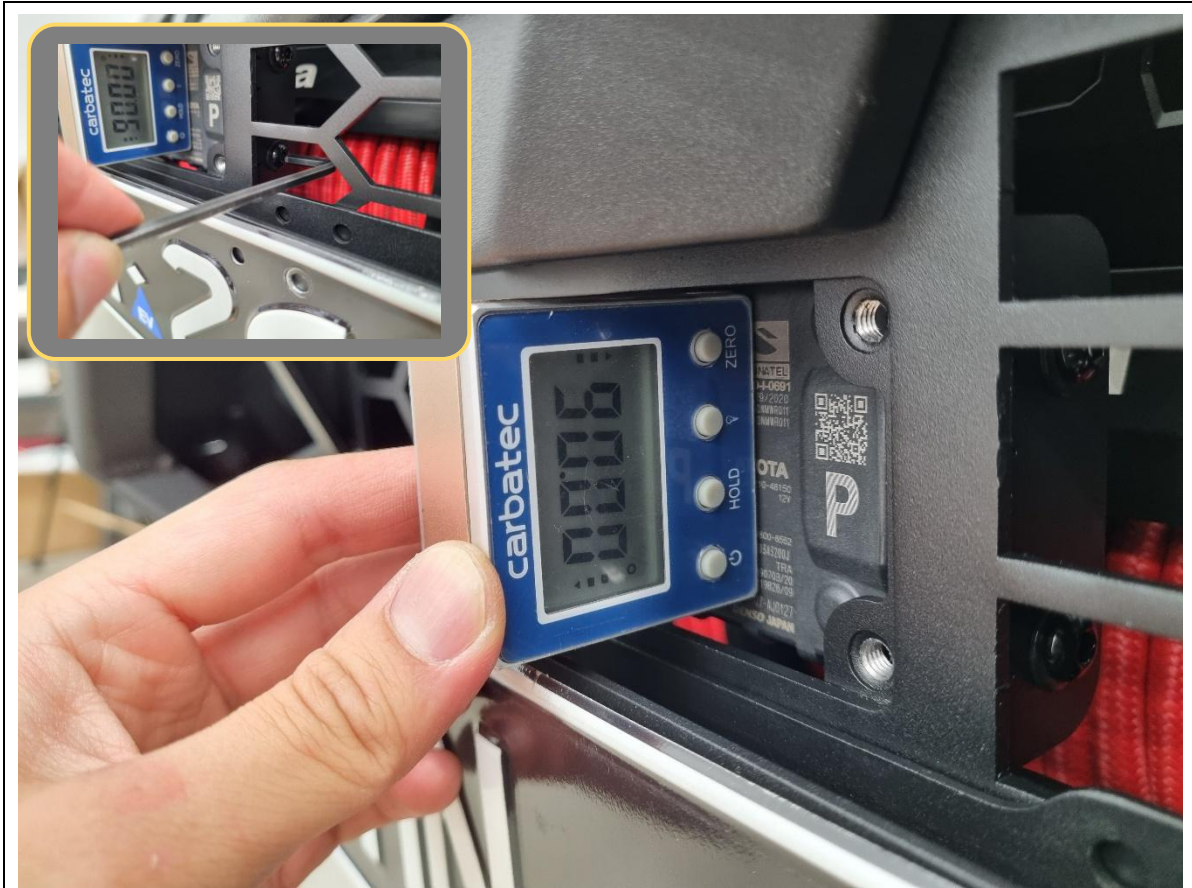

- 177. Hold up a digital angle gauge or other measuring tool to the front face of the radar.
- 178. Adjust the radar so that the radar is sitting 90deg perpendicular to the ground.
- 179. Once aligned, tighten the 4x M6 button head bolts holding the radar (see inset photo).

**TOOLS REQUIRED**

- Digital angle gauge
- 4mm hex/Allen key

**FASTENERS**

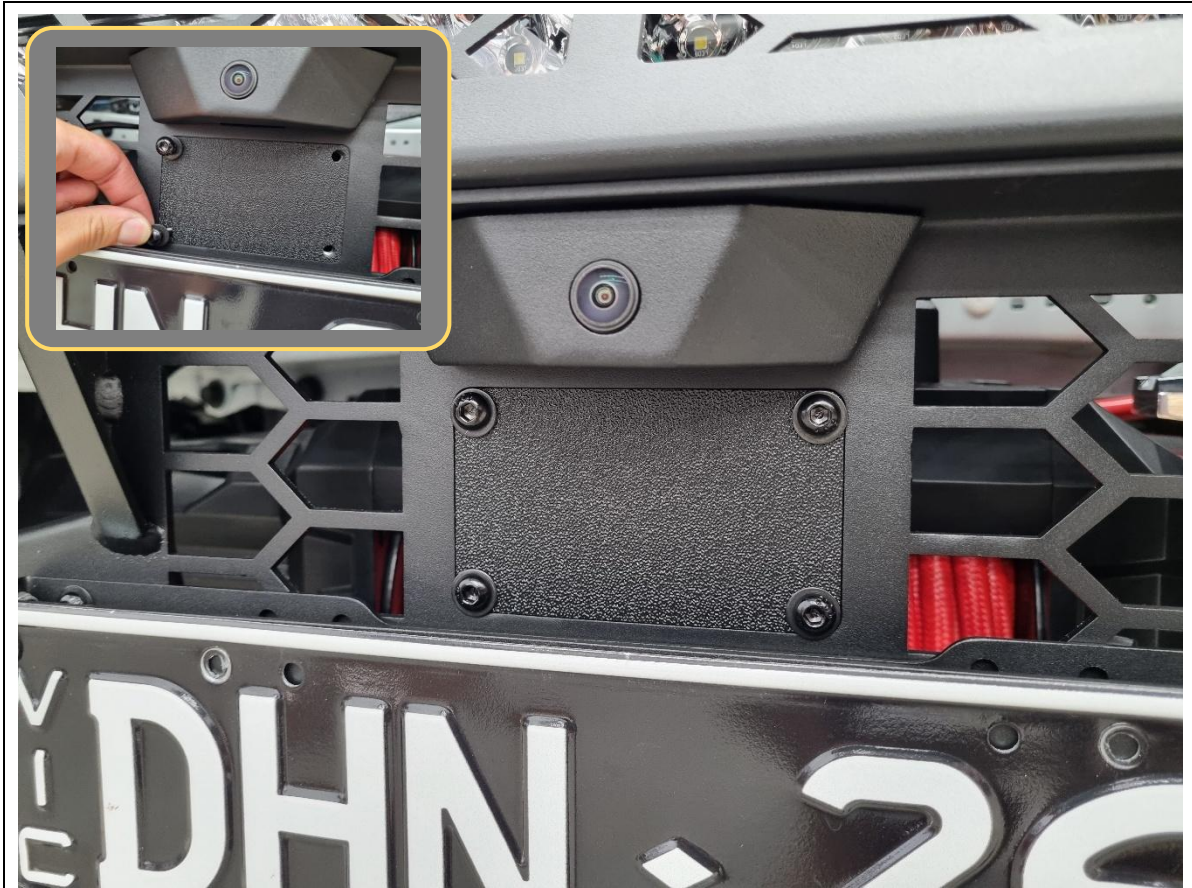

- 180. Fit the supplied plastic N-0017 radar cover panel and secure to the centre mesh with 4x M6x16 black button head bolts and black washers.
- 181. Once all the parking sensor, radar and camera cables are connected, turn the car on test the operation of the camera and parking sensors.

**TOOLS REQUIRED**

4mm hex/Allen key

**FASTENERS**

4x M6x16 black button head bolt  
4x M6 black flat washer



182. Pull out the headlight washer nozzles from the bar by hand, and adjust the angle of the 2x nozzles on each unit so that they are aiming at the headlight. The nozzles can be rotated left/right and up/down.

183. Check the correct aim and operation of washer nozzles by turning the vehicle on with main beam headlights on and activating the windscreen washer several times.

184. Once happy with aim, fit the original headlight washer covers back on.

**TOOLS REQUIRED**

**FASTENERS**





185. The flares now need to be cut to match the bar. This will be done iteratively. To make it easier to fit/remove the flare, temporarily remove some of the clips on the inside of the flare.

186. Hold the flare up the vehicle, and mark out a conservative cut line matching the position of the end of the bar.

187. Make the first conservative cut of the flare with an air hacksaw or similar cutting tool. Check if the flare can be fitted to the vehicle and will not intersect with the bar. Make further cuts if necessary until it just clears the bar. You do not want a big gap just yet.

188. Temporarily clip the flare onto the vehicle, then mark out a precise cut line that is 20mm away and parallel to the edge of the bar, as shown in the main image above.

**TOOLS REQUIRED**

Masking tape  
Marker pen

Safety glasses

Air Hacksaw  
or  
Oscillating Multi Tool  
or  
Angle Grinder  
or  
Jigsaw

**FASTENERS**

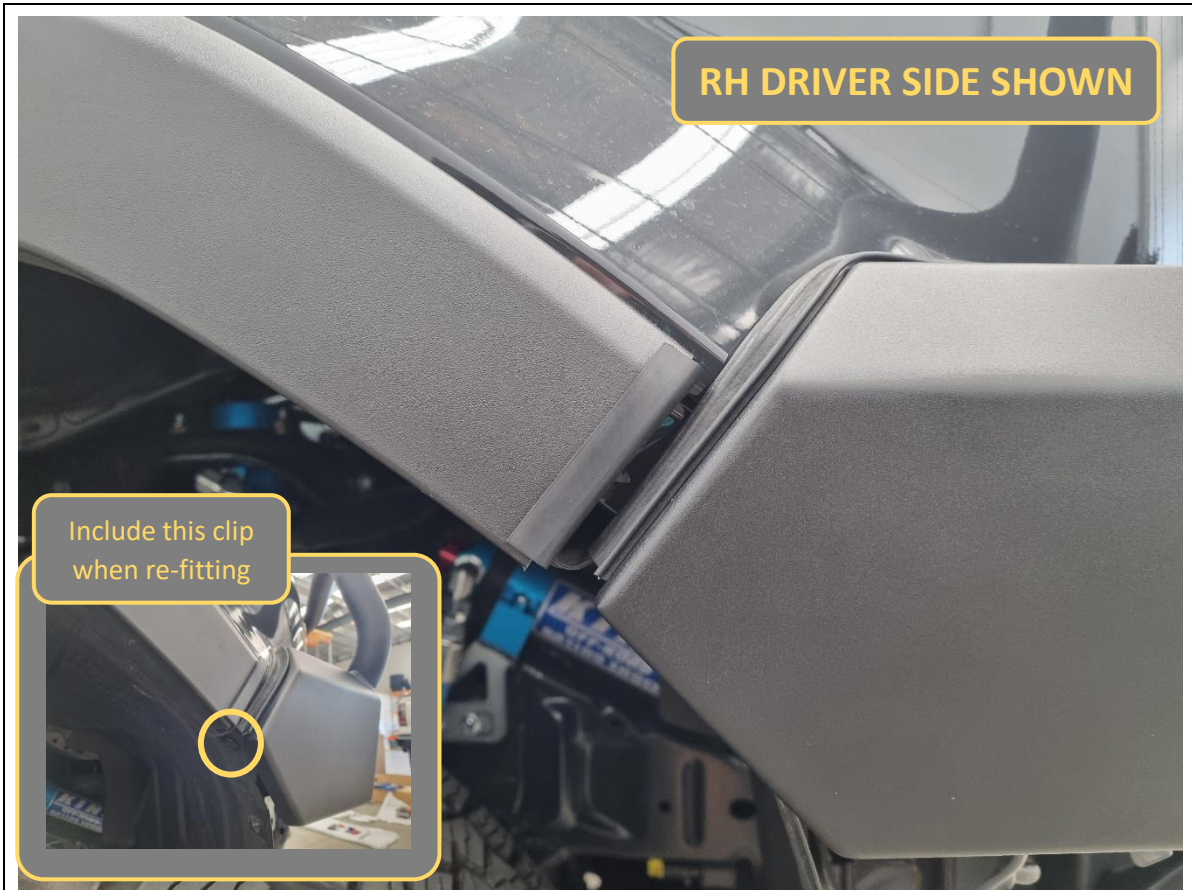

<p>189. Perform a final cut of the flare. Deburr and clean up the cut edge.</p> <p>190. Re-fit any body clips that were removed.</p> <p>191. If desired, trim and fit the supplied U-channel rubber to the cut edge. Use a small amount of Sikaflex or superglue to ensure it does not fall off.</p> <p>192. Re-fit the cut flares and mudflaps to the vehicle using original fasteners.</p> <p>193. Finish up wiring of winches/driving lights, then re-fit the radiator top cover and close the bonnet.</p>	<p><b>TOOLS REQUIRED</b></p> <p>Safety glasses</p> <p>Air Hacksaw or Oscillating Multi Tool or Angle Grinder or Jigsaw</p> <p>Utility knife or deburring tool</p> <p>Side cutters</p> <p>Sikaflex or superglue</p>
	<p><b>FASTENERS</b></p>

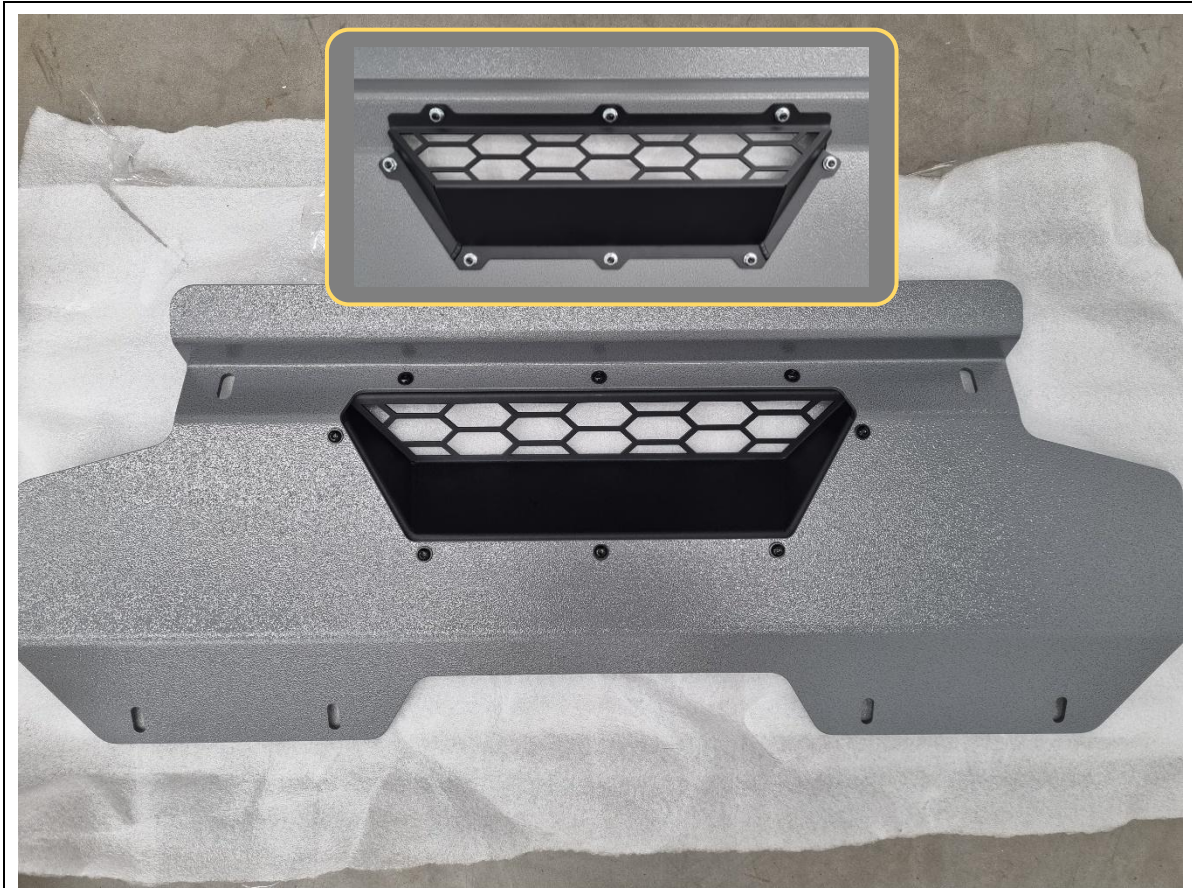

- 194. Fit the cooling mesh to the opening on the inside of the bash plate.
- 195. Secure using 8x M6x16 black button head bolts, black washers and flange nuts.

**TOOLS REQUIRED**

4mm hex/Allen key

**FASTENERS**

8x M6x16 black button head bolt  
8x M6 black flat washer  
8x M6 flange nut





196. Fit the bash plate to the underside of the bar.

197. Secure to the bar at the front with 4x M8x30 black button head bolts and black washers.

198. Secure to the impact assemblies at the rear with 2x M10x25 button head bolts, standard washers and flange nuts.

Reach in through the centre winch opening to fit the flange nut (see inset photo).

**TOOLS REQUIRED**

5mm hex/Allen key

**FASTENERS**

4x M8x30 black button head bolt  
4x M8 flange nut

2x M10x25 button head bolt  
2x M10 standard flat washer  
2x M10 flange nut



<p>199. Peel off the backing film and affix the ADR compliance plate to the inside of one of the LH side underpanel.</p>	<p><b>TOOLS REQUIRED</b></p>
	<p><b>FASTENERS</b></p>

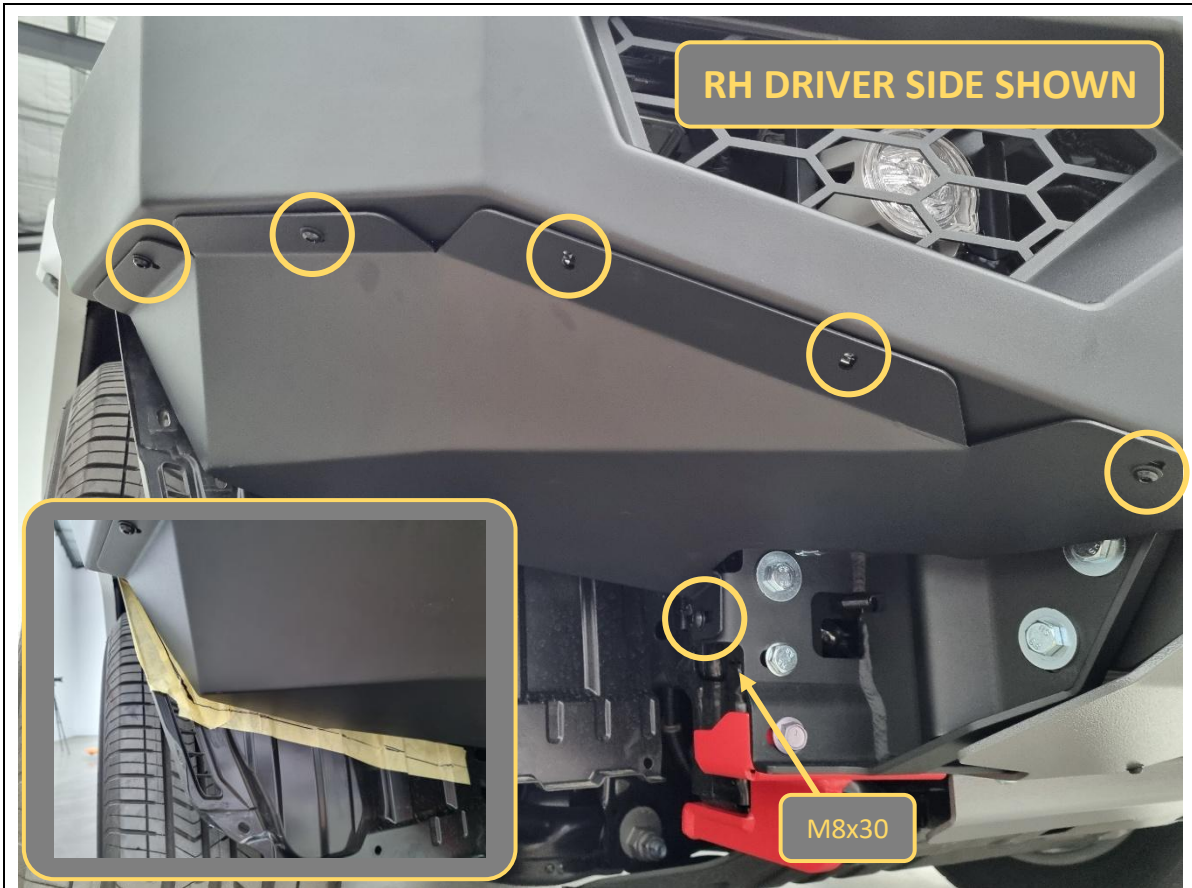

- 200. Fit the side underpanels to the underside of the bull bar wings.
- 201. Loosely secure each one with 5x M6x16 black button head bolts and black washers, plus 1x M8x30 black button head bolt, black washer and flange nut.
- 202. Apply masking tape to the wheel arch liner, then mark out a cut line that matches the profile of the side underpanel.

**TOOLS REQUIRED**

Masking tape  
Marker pen

**FASTENERS**

10x M6x16 black button head  
10x M6 black flat washer  
2x M8x30 black button head bolt  
2x M8 black flat washer  
2x M8 flange nut





**RH DRIVER SIDE SHOWN**

<p>203. Remove the side underpanels, then cut the wheel arch liners along the marked lines using a utility knife or similar cutting tool.</p> <p>Whilst cutting, pull down on the section to be removed and apply tension, to allow for an easy cut.</p>	<p><b>TOOLS REQUIRED</b></p> <p>Utility knife Deburring tool</p>
<p>204. Clean up the cut edge with a deburring tool or similar.</p>	<p><b>FASTENERS</b></p>



<p>205. Re-fit and fully tighten the side underpanels. Ensure the wheel arch liner is tucked inside the flanges on the back of the side underpanels.</p> <p>206. The fitment is now complete. Double check all fasteners are done up.</p>	<p><b>TOOLS REQUIRED</b></p> <p>4mm hex/Allen key 5mm hex/Allen key</p>
	<p><b>FASTENERS</b></p>



**Congratulations! You're done! Go do that big lap of Straya in your beast of a Prado 250!**