



## Ford Ranger Raptor Next Gen Predator & Toro Front Bar Fitting Instruction

### **IMPORTANT! – READ BEFORE INSTALLATION**

- When installed in accordance with these instructions, the front protection bar does not affect the operation of the vehicles SRS airbags.
- This product must be installed exactly as per these instructions using only hardware supplied.
- Take a few moments to read instructions thoroughly before beginning work.
- In the event of damage to any bar component please contact OFFROAD ANIMAL to arrange repair/replacement of components.
- Do not use this product for any vehicle make or model other than that specified on these instructions.
- Do not remove labels from this product.
- This product and its fixings must not be modified in any way unless stated in these fitting instructions.
- The installation of this product is recommended for trained personnel.
- These instructions are correct at time of publication. OFFROAD ANIMAL cannot be held responsible for the impact of any changes subsequently made by the vehicle manufacturer. If you find something has changed please contact us to let us know!
- During installation it is the duty of the installer to check correct operation/clearances of all components.
- If Instructions are to be printed for reference in the workshop, it is recommended that they are printed in colour, for best legibility.



## PARTS LISTING

**IMPORTANT:** Check all parts are present before beginning work! Contact OFFROAD ANIMAL if something is missing.

### Main Parts – In the Box

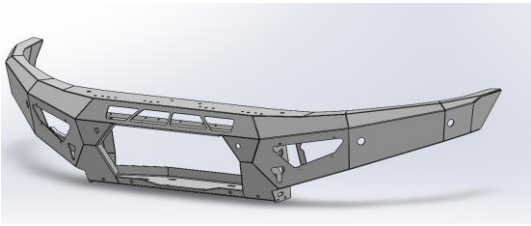
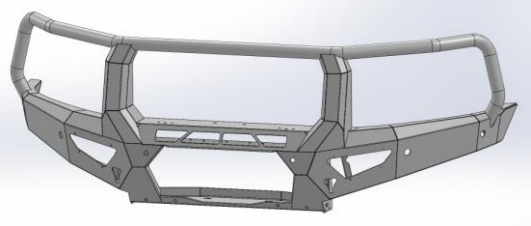
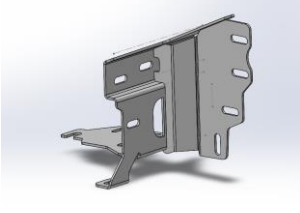
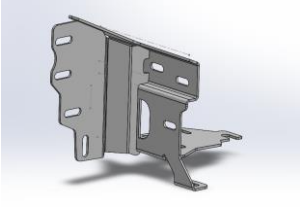
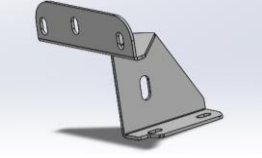
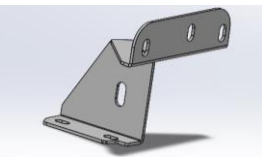
Qty	Part Number	Description	Image
1	FB-FRR-P703-22-PR-ASM1	Next Gen Ranger Raptor Front Bar Weldment	
<b>OR</b>			
1	FB-FRR-P703-22-TOR-ASM1	P703 Ranger Raptor Toro Bar Weldment	
1	FB-FRR-P703-22-PR-ASM2L	Next Gen Raptor Impact Assembly	
1	FB-FRR-P703-22-PR-ASM2R	Next Gen Raptor Impact Assembly	
1	FB-FRR-P703-22-PR-ASM3L	Raptor Next Gen - Chassis Brace Assy	
1	FB-FRR-P703-22-PR-ASM3R	Raptor Next Gen - Chassis Brace Assy	



1	FB-FRA-NG-22-PR-ASM4	Next Gen Ranger Fairlead Mesh Assy	
1	M-0002L	Light Cover Mesh	
1	M-0002R	Light Cover Mesh	
<b>OR</b>			
1	M-0030L	Wing Mesh Panel - Toro With Indicator Repeater	
1	M-0030R	Wing Mesh Panel - Toro With Indicator Repeater	
1	B-0804L	Ford Ranger Next Gen Fog Light Bracket - Small 3 Bolt	
1	B-0804R	Ford Ranger Next Gen Fog Light Bracket - Small 3 Bolt	
1	U-0053	Next Gen RAPTOR Upper Bash Plate	





1	U-0060	Next Gen RAPTOR Lower Bash Plate	
1	U-0054L	Next Gen Ranger Raptor Side Underpanel	
1	U-0054R	Next Gen Ranger Raptor Side Underpanel	
1	B-0780	Next Gen Ranger Predator Pan Brace	
1	P-0244	Ford Ranger Next Gen Radar Mount Plate	
1	B-0806	Next Gen RAPTOR Intercooler Air Guide	
1	B-0807	Next Gen RAPTOR Lower Bash Plate Support Bracket	
1	B-0782	Ford Ranger Next Gen Predator - Number Plate Bracket	
1	N-0004	Ford Ranger P703 Radar Cover Panel	

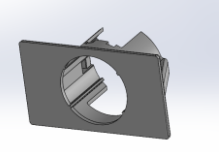
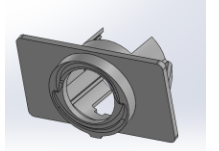
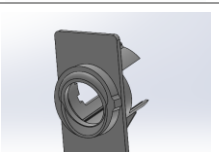
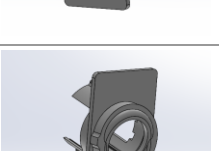

2	F-0010	Ford Ranger Next Gen Sensor Holder - Straight	
2	F-0011	Ford Ranger Next Gen Sensor Holder - 11 Deg Horizontal	
1	F-0013L	Ford Ranger Next Gen Sensor Holder - 11 Deg Vertical	
1	F-0013R	Ford Ranger Next Gen Sensor Holder - 11 Deg Vertical	
1	TK-COM-PSEN-6	Tape Kit - 6 Sensor Universal	No image

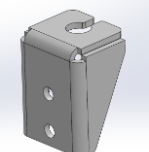
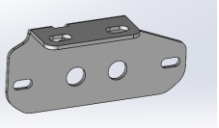
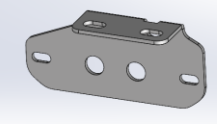
### Toro ONLY Parts – In the Box

Qty	Part Number	Description	Image
2	B-0649	Toro Antenna Bracket – 90 Degree Tall	
1	B-0797L	Toro Indicator Repeater Bracket	
1	B-0797R	Toro Indicator Repeater Bracket	
1	11CAT1M-2	LED Autolamps 11CAT1M-2 Front Indicator - Twin Blister Pack	
<b>Optional Extras</b>			
2	LM-FRA-NG-IND	Indicator Wiring Harness – Next Gen Ranger (If Optioned)	



## Predator Small Parts – Contained in Small Parts Kit Bag

QTY.	PART NO.	DESCRIPTION
8	M10 FW LHD	WASHER, FLAT M10X28.5X2.5
8	M10 FLANGE NUT	Flange Nut, M10x1.5 G8.8 ZP
4	M10x25	Bolt Hex, M10X25x1.5, GR8.8 ZP
4	M8 HD FLAT WASHER	M8 FLAT WASHER - High Tensile 19x8x1.9mm
6	M8 FLANGE NUT	Flange Nut, M8x1.25 G8.8 ZP
4	M8 X 12 HEX	Bolt Hex, M8X12x1.25, GR8.8 ZP
4	M8 X 20 HEX	Bolt Hex, M8X20x1.25, GR8.8 ZP
9	M8 FLAT WASHER- BLACK ZINC	M8 FLAT WASHER, 16.5x8.4x1.2, ISO4042 ZnNi BLACK PASSIVATED FINISH
7	M8 X 20 BHCS BLACK ZINC	SCREW, BUTTON HEAD CAP, M8X20X1.25, ISO4042 ZnNi BLACK PASSIVATED FINISH
2	M8X 16 BHCS BZP	SCREW, BUTTON HEAD CAP, M8X16X1.25 GR12.9, ISO4042 ZnNi BLACK PASSIVATED FINISH
16	M12 FLANGE NUT	Flange Nut, M12x1.75 G8.8 ZP
16	M12 FW LHD	M12 FW Large Heavy Duty
12	M12X30	Bolt Hex, M12X30x1.75, GR8.8 ZP
2	M12 Nyloc nut	M12 NYLOC NUT
42	M6 FLAT WASHER BLACK ZINC	M6 Flat washer, 12x6.1x1, ISO4042 ZnNi BLACK PASSIVATED FINISH
34	M6x16 BHCS BLACK ZINC	SCREW, BUTTON HEAD CAP, M6X16X1 GR12.9, ISO4042 ZnNi BLACK PASSIVATED FINISH
10	M6CN3MM	CAGE NUT M6x2.6-3.5
30	M6 FLANGE NUT	Flange Nut, M6 G8.8 ZP
3	M8 Cage nut	NUT, CAGE, M8X1.25 ZINC PLATE
4	M10X20 BHCS	SCREW, BUTTON HEAD CAP, M10X20X1.5 GR12.9 ZP
8	P-0024	Ranger tow point spacer
4	M12X50	Bolt Hex, M12X50x1.75, GR8.8 ZP
2	M12 FLAT WASHER	M12 FW
2	NP-COM-M12-300- ASM0	M12 NUT PLATE 300MM STEM
3	M6x12 BHCS	SCREW, BUTTON HEAD CAP, M6X12X1 GR12.9 ZP
3	M6x30 BHCS BLACK ZINC	SCREW, BUTTON HEAD CAP, M6X30X1 GR12.9, ISO4042 ZnNi BLACK PASSIVATED FINISH
2	M8 NYLOC	NYLOC SELF LOCKING NUT, ST STL A2 ISO
8	M8 FLAT WASHER	M8 FW
2	M8 X 25 HEX	Bolt Hex, M8X25x1.25, GR8.8 ZP
2	M8 NYW	Washer, M8, Nylon



## Toro Small Parts – Contained in Small Parts Kit Bag

Qty	Part Number	Description
4	M3X12 PAN	SCREW, PAN HEAD PHILLIPS, M3X12X0.5 GR4.6 ZP
4	M3 FLAT WASHER	Flat Washer M3, 7mmODx0.5mm T
4	M3 NUT	Hex Nut, M3x0.5 G48.8 ZP
3	M6x12 BHCS	SCREW, BUTTON HEAD CAP, M6X12X1 GR12.9 ZP
38	M6x16 BHCS BLACK ZINC	SCREW, BUTTON HEAD CAP, M6X16X1 GR12.9, ISO4042 ZnNi BLACK PASSIVATED FINISH
3	M6x30 BHCS BLACK ZINC	SCREW, BUTTON HEAD CAP, M6X30X1 GR12.9, ISO4042 ZnNi BLACK PASSIVATED FINISH
46	M6 FLAT WASHER BLACK ZINC	M6 Flat Washer, 12x6.1x1, ISO4042 ZnNi BLACK PASSIVATED FINISH
32	M6 FLANGE NUT	Flange Nut, M6x1 G8.8 ZP
12	M6CN3MM	CAGE NUT M6x2.6-3.5
2	M8 X 16 BHCS BZP	SCREW, BUTTON HEAD CAP, M8X16X1.25 GR12.9, ISO4042 ZnNi BLACK PASSIVATED FINISH
11	M8 X 20 BHCS BLACK ZINC	SCREW, BUTTON HEAD CAP, M8X20X1.25, ISO4042 ZnNi BLACK PASSIVATED FINISH
4	M8 X 12 HEX	Bolt Hex, M8X12x1.25, GR8.8 ZP
4	M8 X 20 HEX	Bolt Hex, M8X20x1.25, GR8.8 ZP
2	M8 X 25 HEX	Bolt Hex, M8X25x1.25, GR8.8 ZP
8	M8 FLAT WASHER	M8 FW
13	M8 FLAT WASHER- BLACK ZINC	M8 FLAT WASHER, 16.5x8.4x1.2, ISO4042 ZnNi BLACK PASSIVATED FINISH
4	M8 HD FLAT WASHER	M8 FLAT WASHER - High Tensile 19x8x1.9mm
2	M8 NYW	Washer, M8, Nylon
6	M8 FLANGE NUT	Flange Nut, M8x1.25 G8.8 ZP
2	M8 NYLOC	NYLOC SELF LOCKING NUT, ST STL A2 ISO
3	M8 Cage nut	NUT, CAGE, M8X1.25 ZINC PLATE
4	M10X20 BHCS	SCREW, BUTTON HEAD CAP, M10X20X1.5 GR12.9 ZP
4	M10 x 25	Bolt Hex, M10X25x[1.5], GR8.8 ZP
8	M10 FW LHD	WASHER, FLAT M10X28.5X2.5
8	M10 FLANGE NUT	Flange Nut, M10x1.5 G8.8 ZP
12	M12X30	Bolt Hex, M12X30x1.75, GR8.8 ZP
4	M12X50	Bolt Hex, M12X50x1.75, GR8.8 ZP
2	M12 FLAT WASHER	M12 FW
16	M12 FW LHD	M12 FW Large Heavy Duty
16	M12 FLANGE NUT	Flange Nut, M12x1.75 G8.8 ZP
2	M12 Nyloc nut	M12 NYLOC NUT
8	P-0024	Ranger tow point spacer
2	NP-COM-M12-300- ASM0	M12 NUT PLATE 300MM STEM



## TOOLS REQUIRED

The following tools will be required to install the product.

<b>Hand Tools</b>	<b>Power Tools</b>	<b>Workshop Supplies</b>
Metric Socket Set 5.5-19mm Socket Extension Bar Metric Spanner Set 5.5-19mm Hex (Allen) Key Set 4-6mm Torx Key Set Trim Puller Tool Flat Blade Screwdriver set Phillips Head Screwdriver set Utility Knife Side Cutters Pliers Wire Strippers (Toro Only) Crimping Tool (Toro Only)	Electric/Air Impact Driver (Optional) Air Hacksaw Or Oscillating Multi Tool Or Angle Grinder	Panel Stand or Soft Blanket Cable Ties Masking Tape Black Automotive paint Scotch Brite or Fine Sandpaper Crimp terminals (Toro Only)



# WORKSHOP SAFETY

It is the responsibility of the installer to always complete works in a safe manner. Make sure the following safety equipment is available and precautions are observed whilst fitting this product.

<p>Hearing Protection</p> 	<p>Always wear ear protection when using power tools.</p>
<p>Eye Protection</p> 	<p>Ensure eye protection is always worn when cutting or drilling.</p>
<p>Manual Handling</p> 	<p>Do not attempt to lift bar assemblies or rock sliders on your own.</p> <p>Always use two people to lift or use mechanical Lifting aid such as hydraulic lifting trolley.</p>
<p>Vehicle Support</p> 	<p>Always ensure vehicle is properly supported when working on it. Do not attempt to fit products whilst suspension work is being carried out. Do not work under a vehicle supported only by a jack.</p>

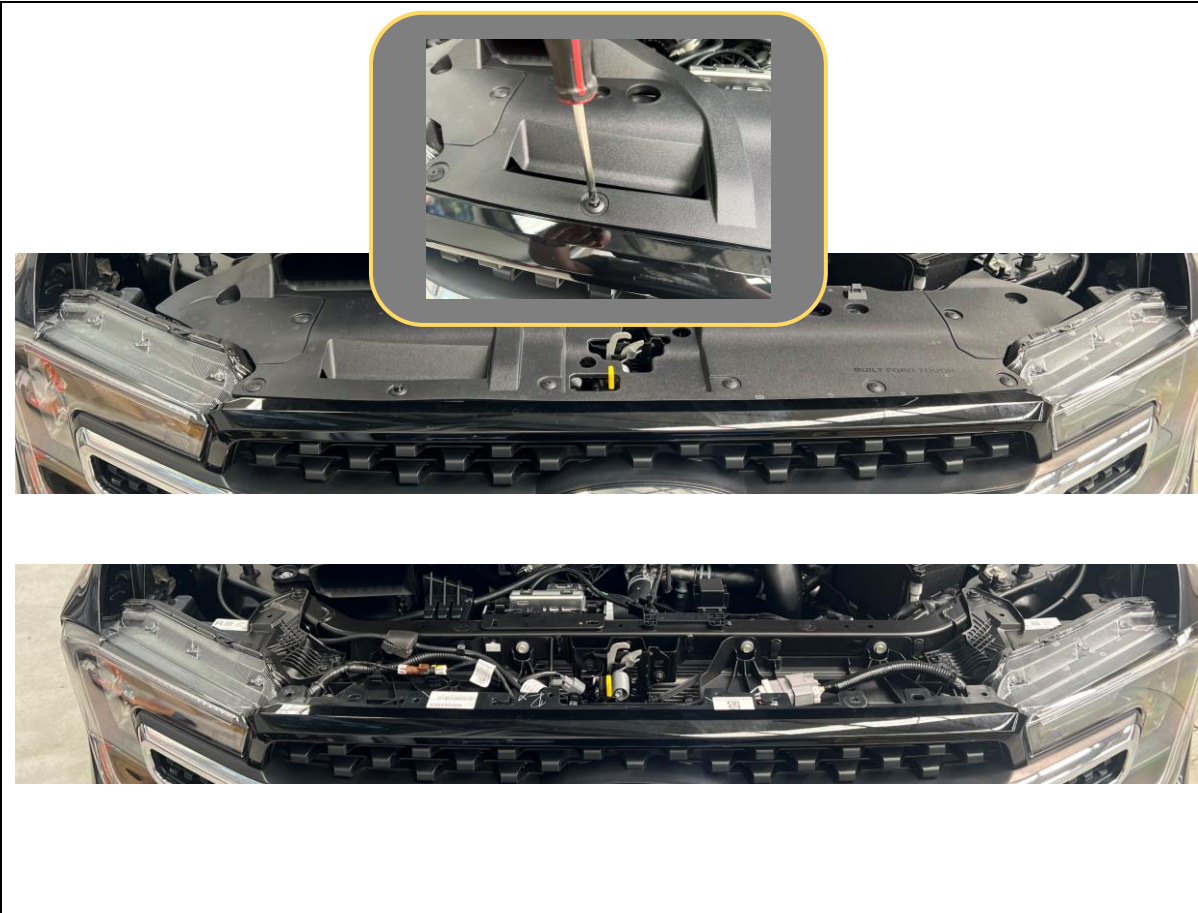

<ol style="list-style-type: none"> <li>1. <b>If Relocating Front Camera – Read and understand camera relocation bracket instructions before beginning work.</b></li> <li>2. <b>DO NOT turn on or move car whilst any camera or radar systems are disconnected. Failure to observe this precaution will result in system errors that will need car to be taken to Ford Dealership to resolve.</b></li> </ol>	<p><b>TOOLS REQUIRED</b></p> <p>8mm spanner Trim Tool Phillips Screwdriver</p>
<ol style="list-style-type: none"> <li>3. Open the Bonnet.</li> <li>4. Remove scrivets securing the top radiator cowling. Unscrew center section with Phillips screwdriver to unlock, then remove clip with trim tool.</li> <li>5. Retain all clips for reassembly.</li> <li>6. Loosen the 2x Bolts securing the grille to the radiator panel.</li> </ol>	<p><b>FASTENERS</b></p> <p>Retain Factory</p>



7. Unplug the main wiring harness connector, located adjacent to the left-hand headlight.
8. Unclip the main wiring harness from all locations where it is secured the radiator support panel.

**TOOLS REQUIRED**

Trim Tool

**FASTENERS**



9. Using T20 Torx driver remove the screws securing the tow point covers.
10. Once removed, pull from lower edge to remove tow point covers.

**TOOLS REQUIRED**

T20 Torx

**FASTENERS**

Discard Factory



11. Remove the Factory Flange bolts that secure the center front bash plate with 15mm Socket.
12. The back two bolts on the engine crossmember can just be loosened to allow the plate to slide forward on removal
13. Set aside bash plate.

**TOOLS REQUIRED**

15mm socket

**FASTENERS**

Factory Bolts - Retain



14. Remove the center silver trim on the bumper, by pulling firmly to release clips.

**TOOLS REQUIRED**

**FASTENERS**



15. This will reveal the impact beam. The above photo shows the location of the clips securing the silver trim.

**TOOLS REQUIRED**

**FASTENERS**



16. Using 15mm Socket / Spanner remove the 15mm bolts securing the lower bumper to the chassis rail.
17. **IMPORTANT:** release and feed through the main wiring harness before removing the bumper. Unclipping the side of grille from the headlight can make this process easier
18. Remove the bumper from the vehicle and set aside on a soft surface.

**TOOLS REQUIRED**

15mm Spanner / Socket

**FASTENERS**

Factory Clips



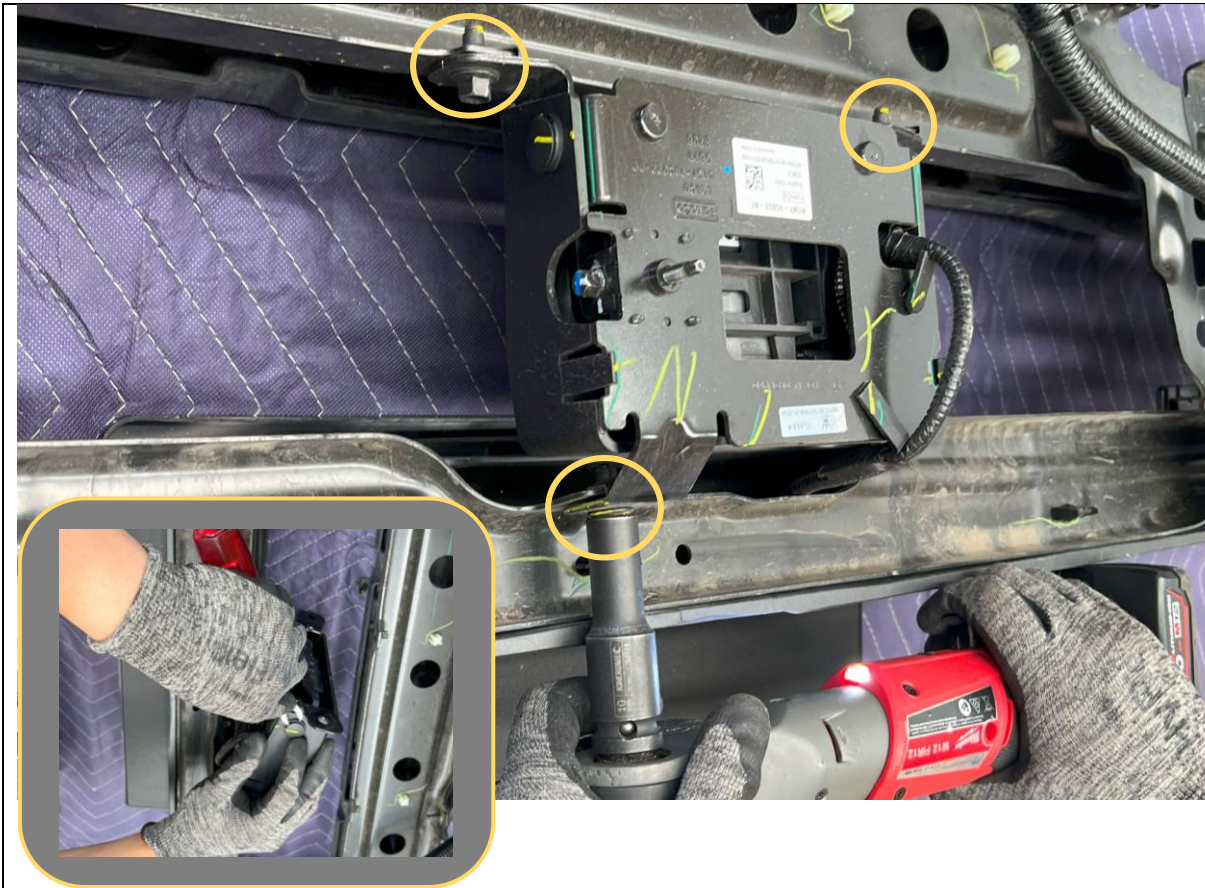

19. Remove radar sensor assembly from the bumper.
20. It is secured to the bumper with 3x bolts, Remove with 10mm Socket/spanner. The plastic cover will also need to be unclipped and removed to be able to unplug sensor from the harness.
21. Set aside sensor module in a safe place for refitment to the bar later.

**TOOLS REQUIRED**

10mm Socket / Spanner  
Trim Tool

**FASTENERS**

Discard Factory



- 22. Unplug and remove the fog lights.
- 23. Remove and discard the T20 Torx screws securing to the bumper.
- 24. Retain fog lights for re-fitment to the bar.

**TOOLS REQUIRED**

T20 Torx Driver

**FASTENERS**

Discard Factory

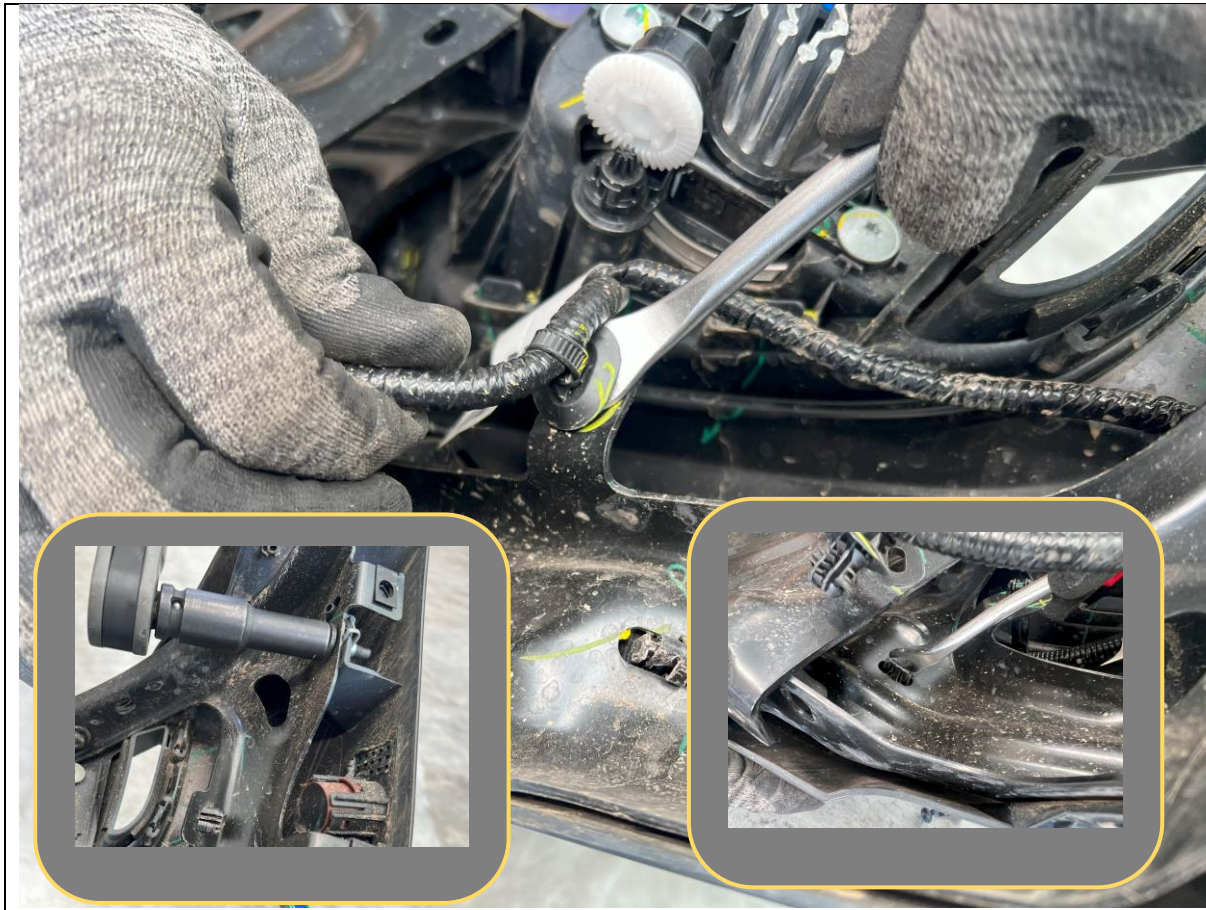

25. Unclip the factory wiring harness from the bumper.
26. Next, we want to separate the inner metal part of the bumper from the outer piece. Remove the annoyingly large number of bolts securing the two pieces together.
27. Finally unclip the zillion or so clips that secure the inner part of the bumper. Work methodically from one end to the other.
28. Once you think you have them all done, begin to separate inner. Excessive resistance will show the clips / bolts you have invariably missed, undo then continue.

**TOOLS REQUIRED**

10mm Socket / Spanner  
Trim Tool

**FASTENERS**

Discard Factory



- 29. Finally, success! Throw that blasted center section to the other side of the workshop!
- 30. Now with sufficient access, remove the wiring harness and parking sensors from the outer bumper. Ensure you keep the parking sensors in their correct locations.

**TOOLS REQUIRED**

Trim Tool

**FASTENERS**

Discard Factory



31. Remove the plastic intercooler air guide from the intercooler.
32. Discard air guide.

**TOOLS REQUIRED**

8mm Socket / Spanner

**FASTENERS**

Discard Factory



33. Remove the factory nut plates from behind the chassis end plates.
34. The nut plates are secured by a small plastic nut on a stud on the back side of the end plate. This should be able to be undone by hand.
35. **If Relocating Front Camera – Camera and washer can be removed from grille. Refer to Camera relocation kit instructions.**

**TOOLS REQUIRED**

**FASTENERS**

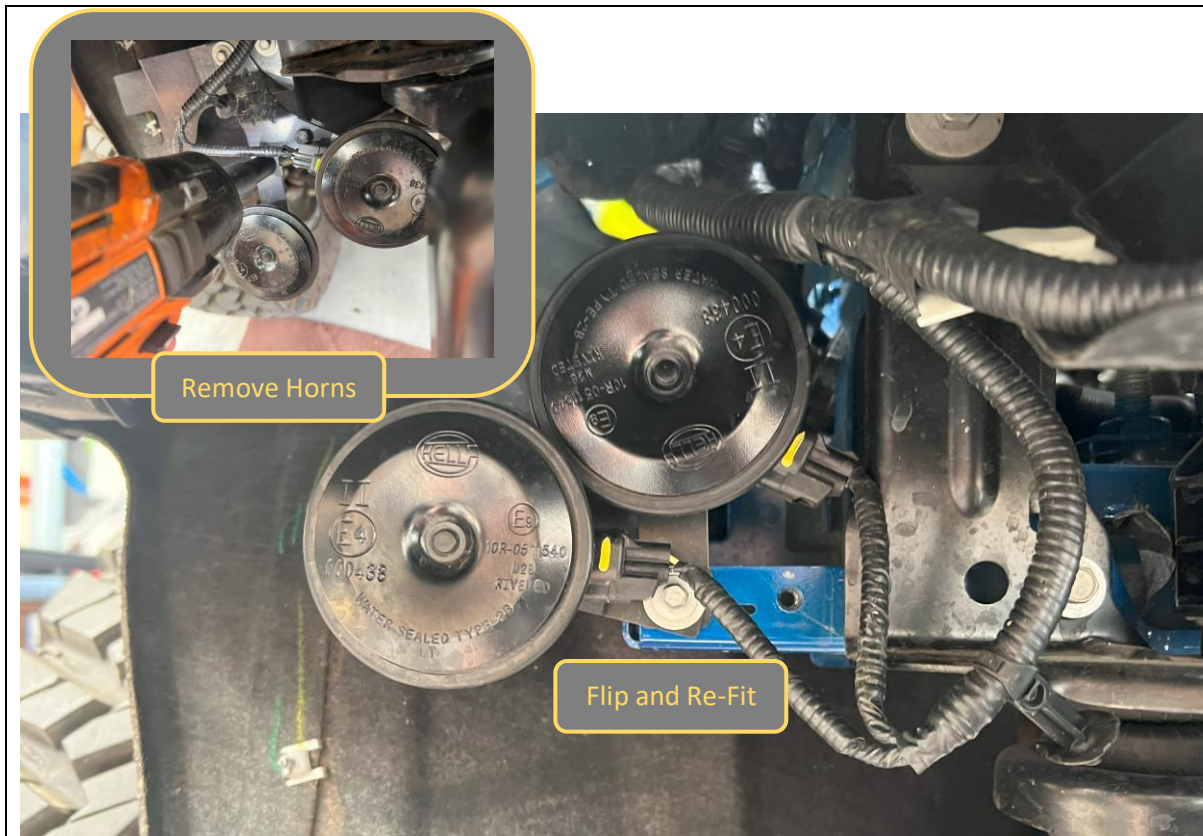

<p>36. Remove bolt and clip securing the Horns from body underneath the RH headlight. Use 10mm Socket.</p> <p>37. Remove the center Y shaped bracket and re-secure horns, flipped 180 degrees to the chassis, using OE Bolt.</p>	<p><b>TOOLS REQUIRED</b></p> <p>10mm Socket Trim Tool</p>
	<p><b>FASTENERS</b></p> <p>Factory Fasteners - Discard</p>

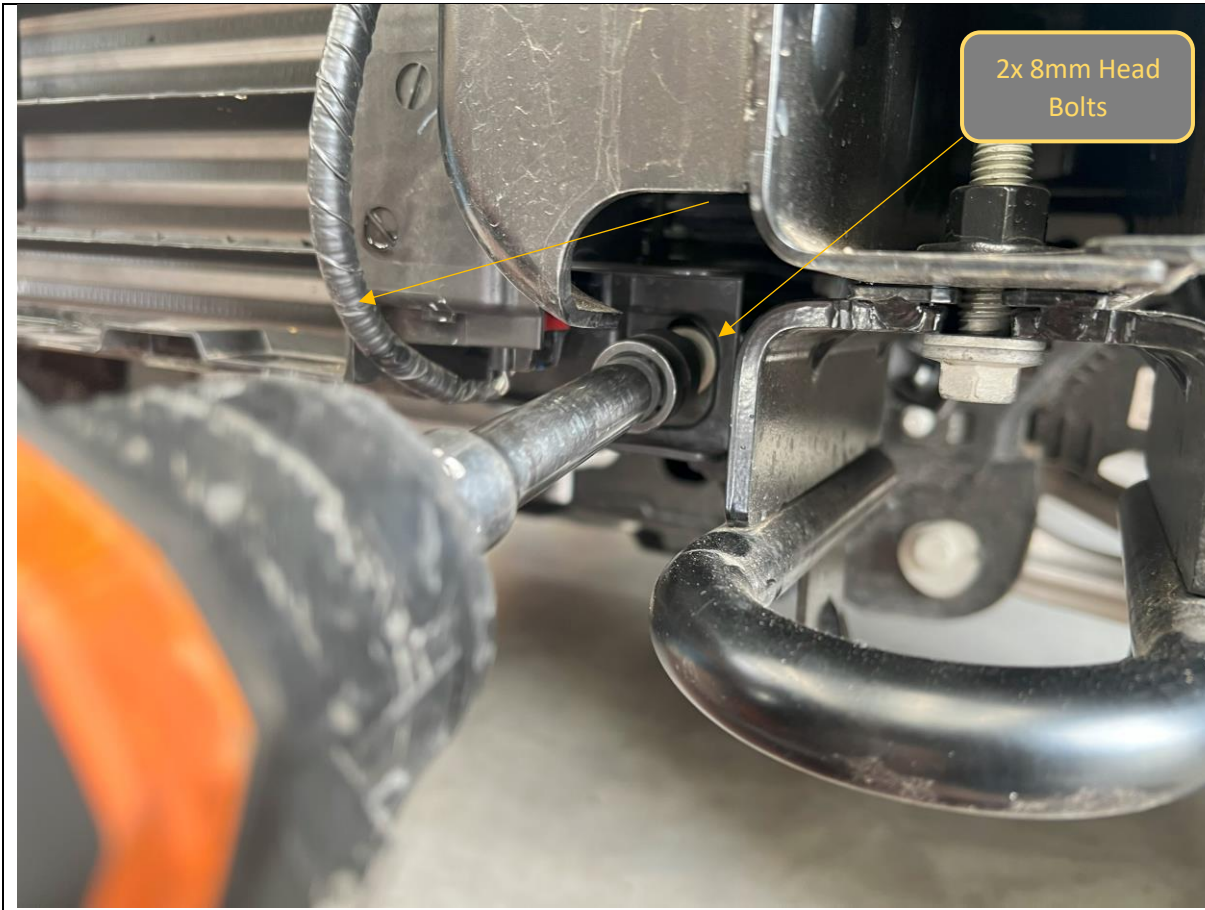

- 38. Remove the fasteners securing the Louvres to the lower tow point mounting bracket.
- 39. Retain fasteners for re-fitment.

**TOOLS REQUIRED**

8mm Socket

**FASTENERS**

Retain OE





- 40. Temporarily support the intercooler by strapping to the upper intercooler support brackets.
- 41. This is best done with relatively short camlock straps or similar, Ensure the straps do not obstruct the lower rubber intercooler mounts

**TOOLS REQUIRED**

Camlock Straps

**FASTENERS**

Phillips Head screw.  
Discard



42. Remove the Tow points from the bottom of the chassis rail, by removing the 2x factory Flange Bolts with 17mm socket.
43. An extension bar is required to access the rearmost bolt
44. Complete for both Tow Points. Retain tow points and bolts for re-fitment.

**TOOLS REQUIRED**

17MM socket / Spanner  
Extension Bar

**FASTENERS**

Retain Factory Bolts

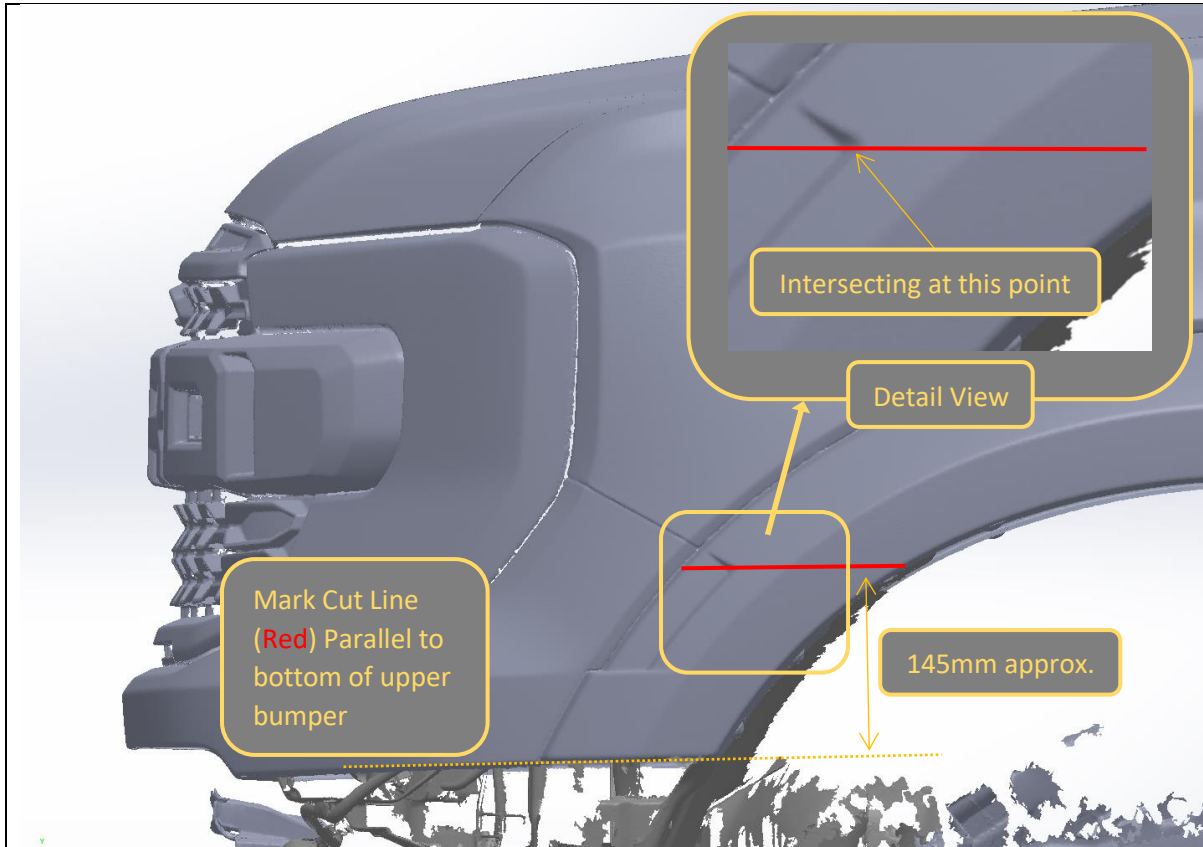

<p>45. Mark the fender flare cut line as shown in the diagram above.</p>	<p><b>TOOLS REQUIRED</b></p> <p>Masking tape</p>
<p>46. The cut line is to be parallel to the bottom of the upper bumper / flare and intersecting the corner of moulded flare pressing.</p> <p>The vertical spacing should be approximately 145mm from the bottom of the flare.</p> <p>The cut will be the full width of the flare.</p>	<p><b>FASTENERS</b></p>



47. Remove the 2x T20 Torx head screws securing the flare to the upper bumper.
48. Carefully but firmly pull the lower edge of the flare outward to release the clips securing it to the upper bumper panel.
49. Carefully trim fender flare along the horizontal tape edge marking the cut line made in previous steps. We recommend using an oscillating multi tool with plastic cutting blade for control and clean edge.

**TOOLS REQUIRED**  
T20 Torx Driver  
Oscillating multi tool  
Or  
Air Hacksaw

**FASTENERS**

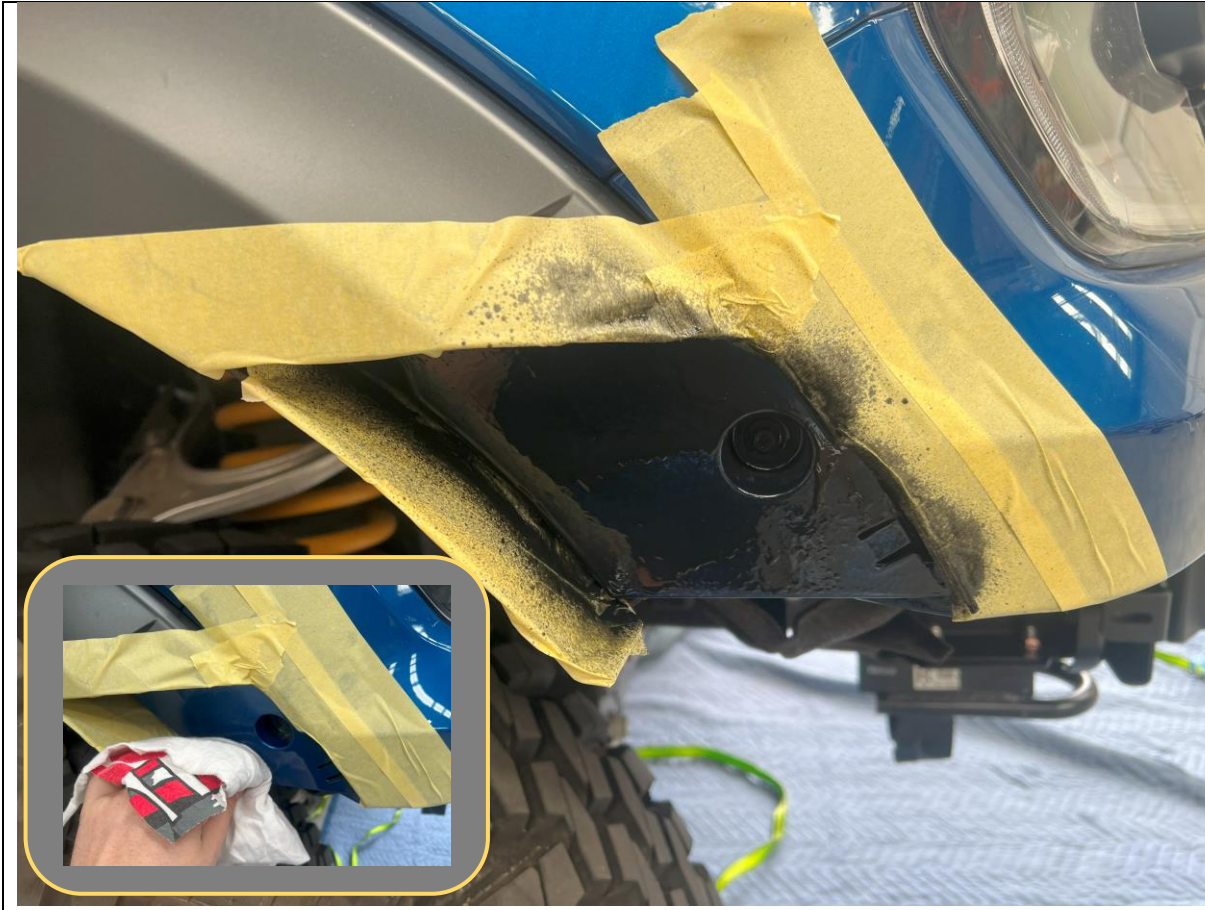

- 50. Mask area underneath flare trim with masking tape.
- 51. Clean area with isopropyl alcohol or other cleaning solvent.
- 52. Paint area with matte black automotive paint.

**TOOLS REQUIRED**  
Trim Tool  
Phillips Screwdriver  
10mm Socket

**FASTENERS**

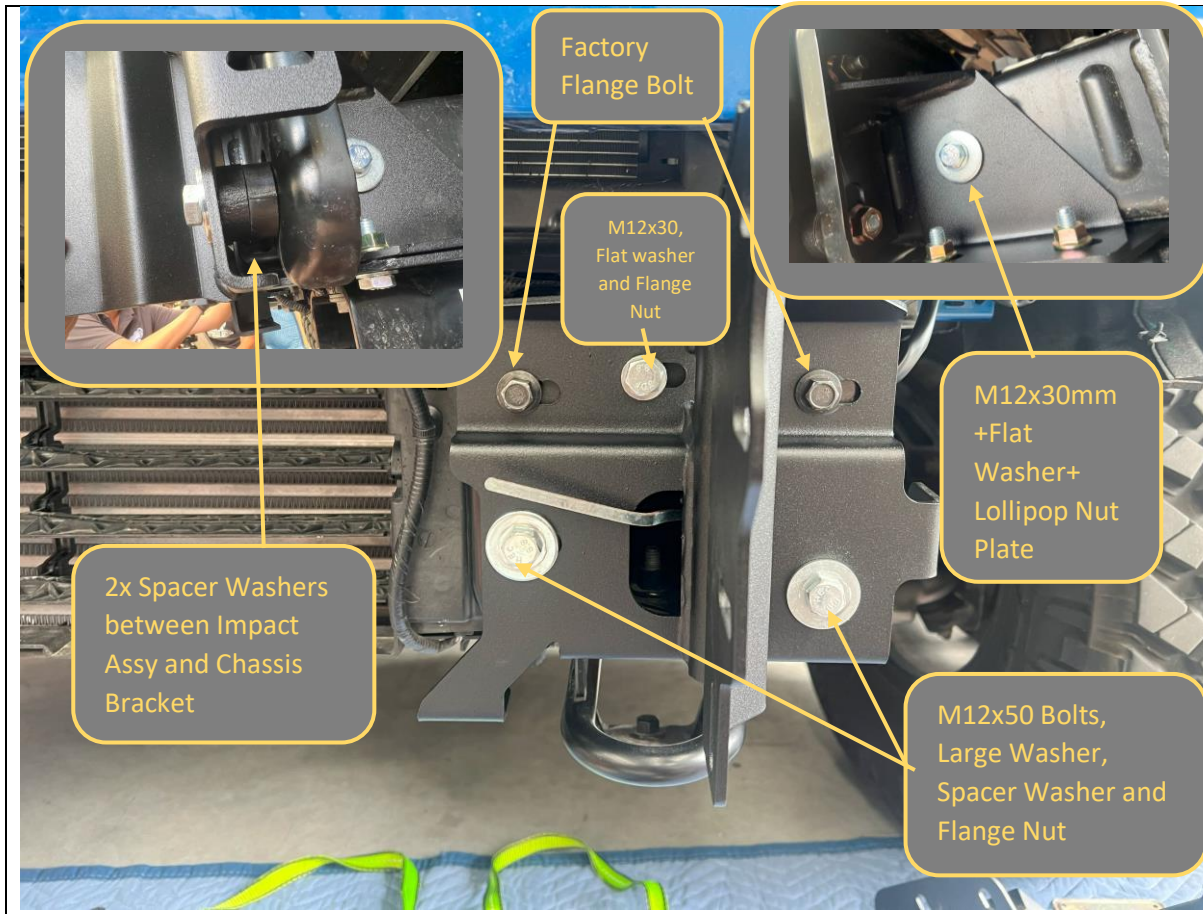

<p>53. Identify and unpack the Impact assembly, and Chassis support bracket for each side</p> <p>54. Loosely fit the parts to the vehicle chassis, first placing the chassis support bracket behind the chassis horn, then fitting the impact assembly from the front.</p>	<p><b>TOOLS REQUIRED</b></p>
<p>55. Secure with fasteners as shown above. The factory bolts have a M12 Flange Nut on the back.</p>	<p><b>FASTENERS</b> See Image</p>

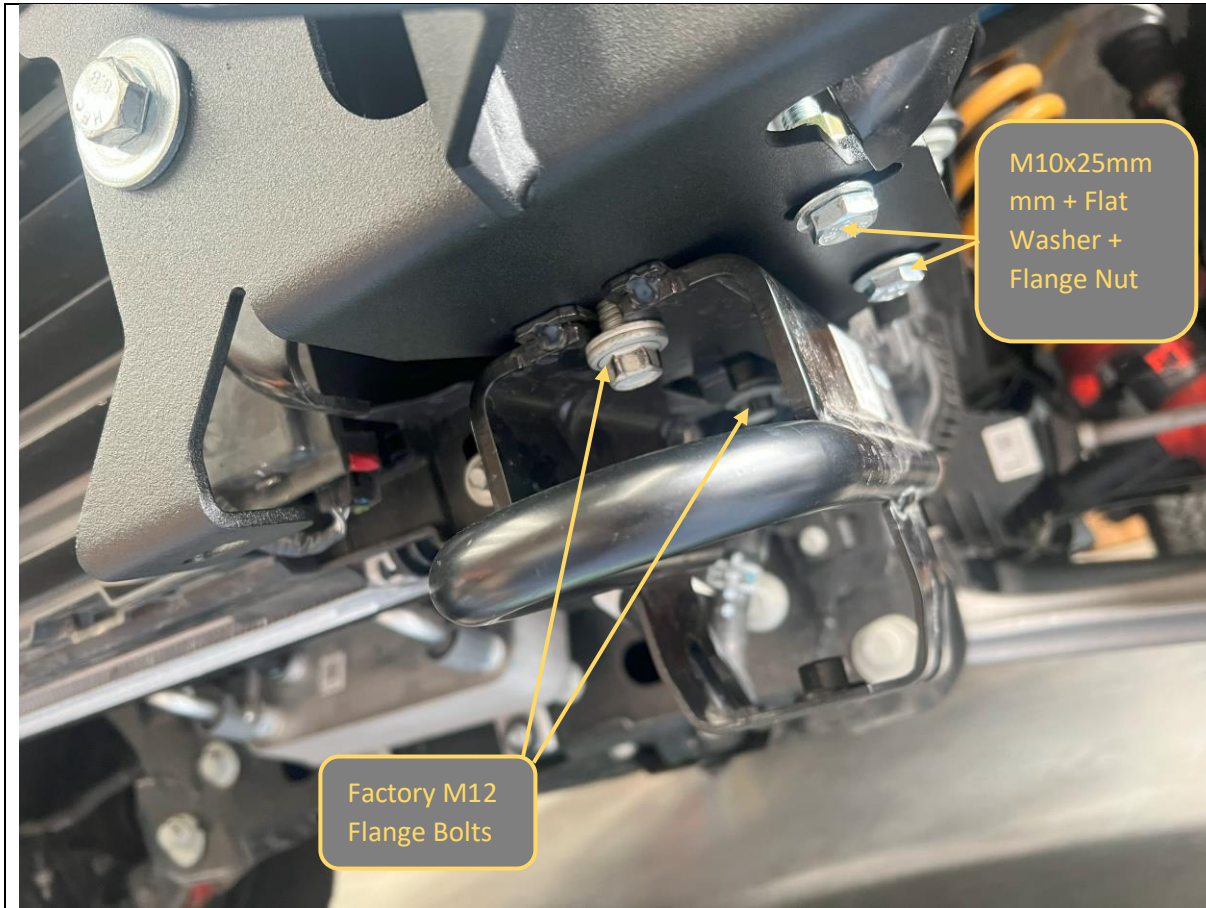

56. Re fit the tow point, through the impact assembly, then secure the impact assembly to chassis brace using fasteners shown.
57. Leave all bolts that secure tow point and impact assembly, including the bottom flange bolts that go through chassis loose at this stage

**TOOLS REQUIRED**

**FASTENERS**

As shown in image

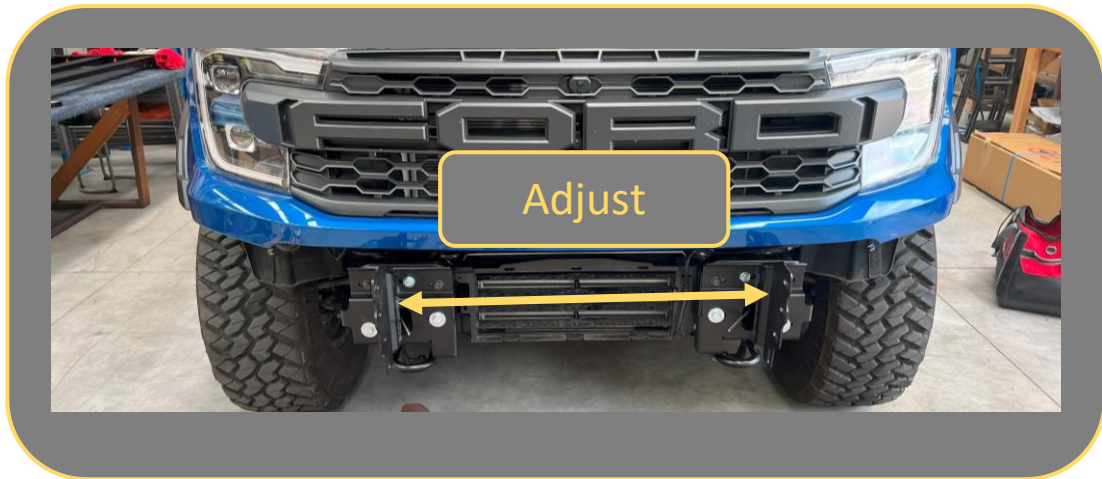
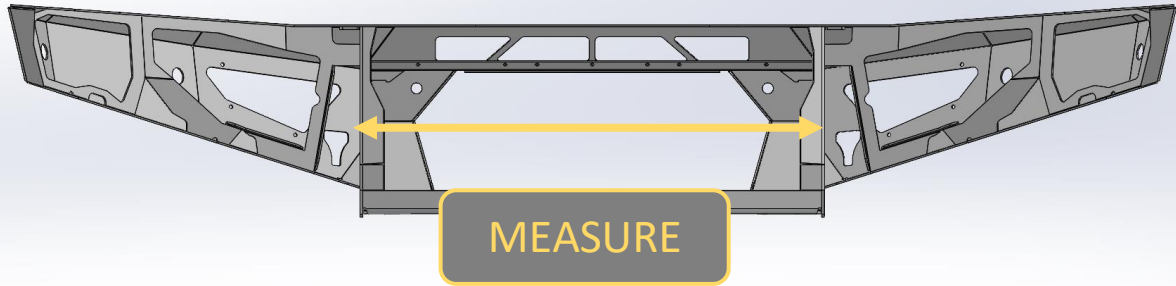

58. Measure Distance between outside edges uprights on bar using tape measure. Write distance below for reference if required.

Bar Upright Width = \_\_\_\_\_mm

59. Adjust mounts by sliding mounts on slots, such that distance between outside edges of mounts is approximately 2-4mm more than the bar.

60. Secure and tighten mounts. Tighten bolts that secure the tow point to chassis first, then impact assembly to chassis bolts.

**TOOLS REQUIRED**

TAPE MEASURE

**FASTENERS**





61. Once mounts are tight, re-fit the louvre panel to the tow points using the factory fasteners.

62. Release and remove the temporary intercooler support straps.

**TOOLS REQUIRED**

**8mm Spanner / Socket**

**FASTENERS**



63. Fit the indicator repeater lamps to the indicator brackets, using M3 Phillips head Screws and the adhesive backing included with the lamp module.

**TOOLS REQUIRED**

Phillips Head Screwdriver  
5.5mm socket/spanner

**FASTENERS**

4x M3 screws  
4x M3 washers  
4x M3 nuts



**TORO BARS ONLY**

<p>64. Insert the M6 Cage nut into the square hole in the top corner of the Mesh panel.</p> <p>65. Fit the indicator brackets to the mesh panel, using the supplied M6 Fasteners. The indicator should be located centrally in the cutout.</p>	<p><b>TOOLS REQUIRED</b></p> <p>4mm Allen Key 10mm Spanner / Socket</p>
	<p><b>FASTENERS</b></p> <p>2x M6x16 BHCS – Black 2x M6 Flat Washer 2x M6 Flange Nut</p>



66. Fit the fog lights to the fog light brackets using 3x M6x16 black button head bolts, washers and flange nuts.
67. Fit the fog light brackets to the Mesh Panels, using the supplied M8x12 Bolts. Fog lights should face straight ahead when fitted.

**TOOLS REQUIRED**

4mm Allen Key  
10mm Spanner / Socket  
13mm Spanner / Socket

**FASTENERS**

3x M6x16 BHCS – Black  
3x M6 Flat Washer  
3x M6 Flange Nut  
per Side

2xM8x12  
2xM8 Flat Washer  
2x M8 Flange Nut



68. Prepare bar for fitment. Start by routing the Wiring harness through the bar such that all plugs are in the correct location. The main harness connector should sit to the OUTSIDE of the bar upright on the LH side of the vehicle.
69. Dry fit all sensors into their respective positions and take note of the required cable routing and plug orientations, the harness is tight, and it is important to correctly route the harness before gluing down the sensor housings.
70. Fit Light mesh panels to the bar using M6X16 Button head Bolts, Flat washers, and Flange nuts from the Small Parts Kit. Plug in fog lights to determine correct fog light cable route.
71. Secure and tighten using 4mm Allen Key and 10mm Spanner

**TOOLS REQUIRED**

4mm Allen Key  
**10mm Spanner / Socket**

**FASTENERS**

4x M6x16 BHCS – Black  
4x M6 Flat Washer  
4x M6 Flange Nut  
Per Side

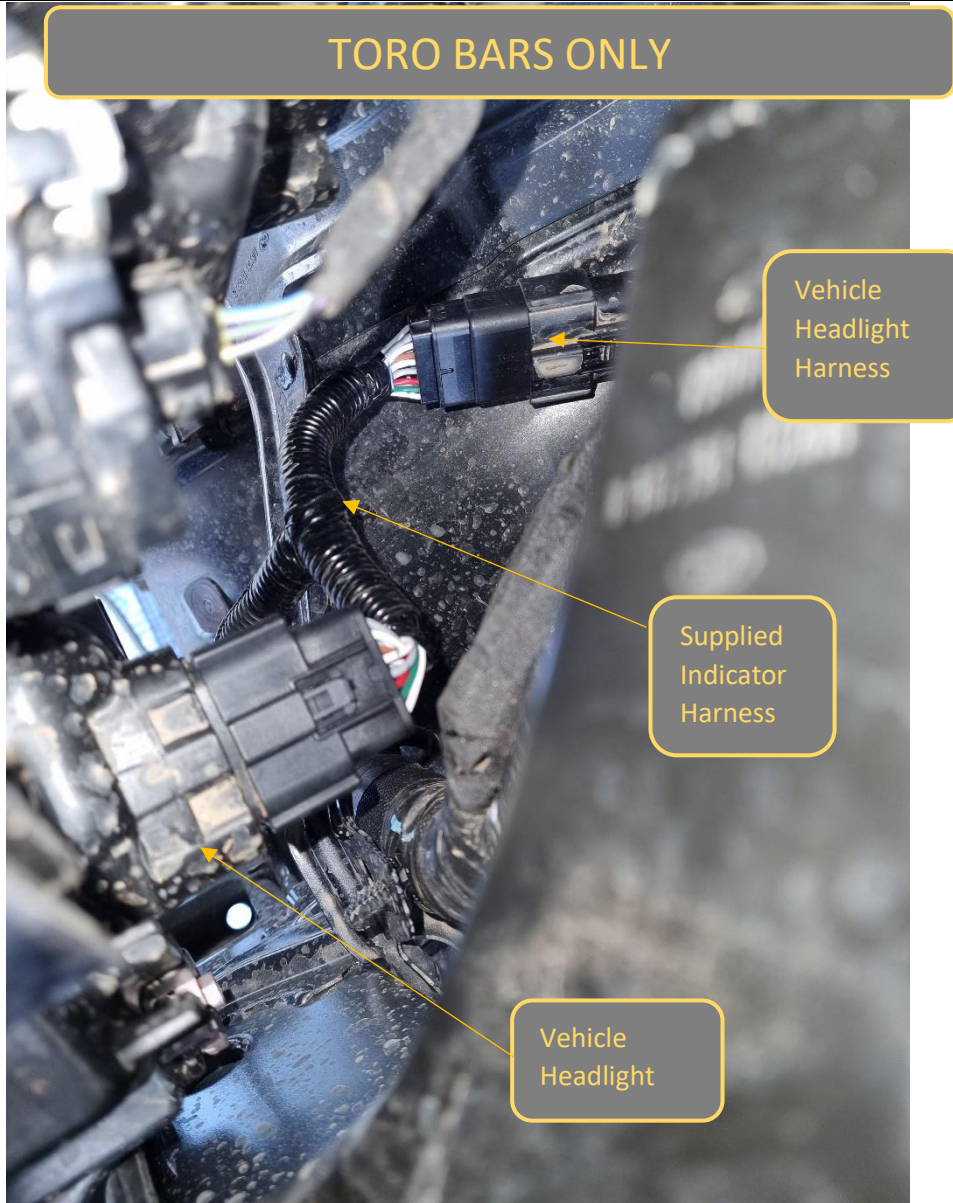

72. The indicators fitted to the Toro bar will need to be spliced and wired and into the vehicle headlights.

73. If the **optional** Offroad Animal LM-FRA-NG-IND Indicator Wiring Harness is to be fitted, unplug the main headlight harness connector located on the back side of the headlight on both sides.

74. Plug in the Indicator breakout harness in-between the vehicle loom and headlight. Ensure the 16 Pin plugs are fully connected to both the headlight and vehicle loom.

**TOOLS REQUIRED**

**FASTENERS**

**TORO BARS ONLY**

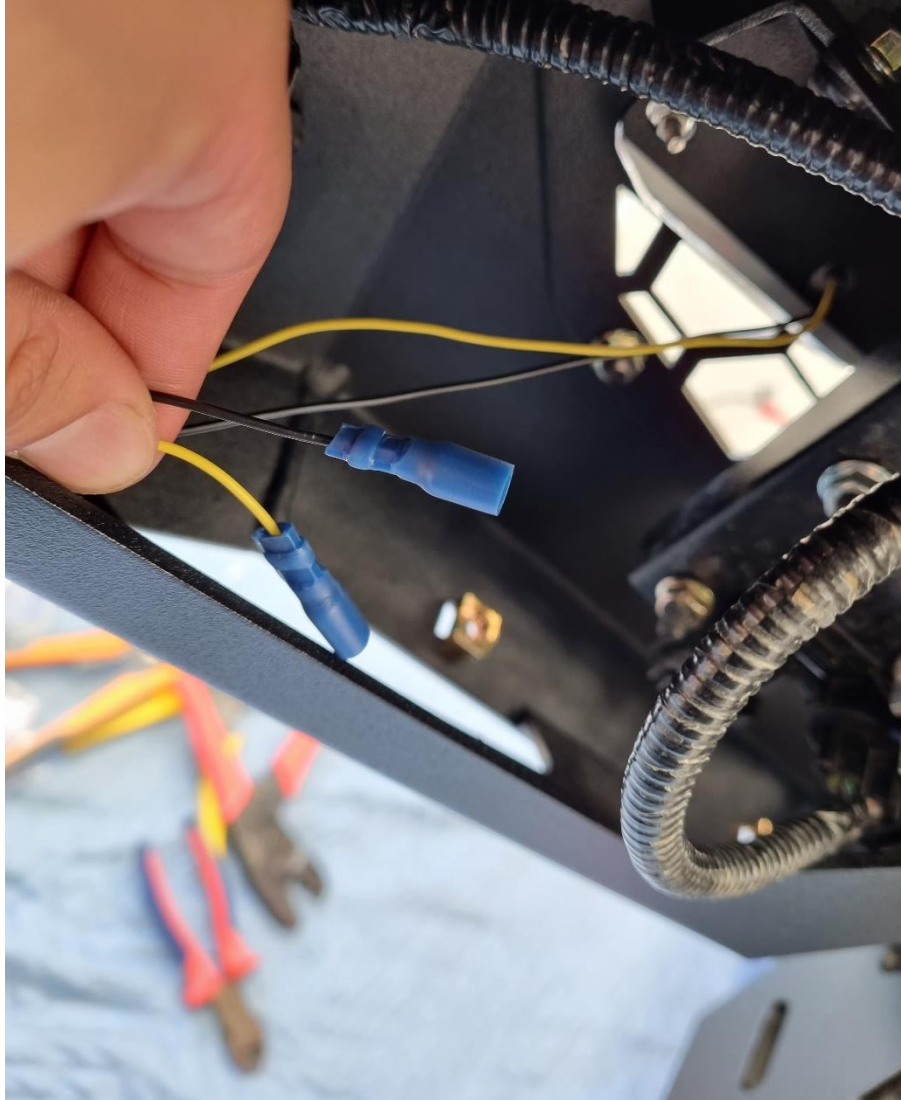

- 75. Fit crimp terminals to the indicator wiring in the bar, and matching terminals to the ends of indicator wiring coming from the newly installed indicator harness.
- 76. Yellow = +12V Indicator, Black = Ground
- 77. Other wires coming from harness are High Beam headlight triggers, refer to instruction included with loom for more information.
- 78. Complete for both sides of vehicle.

**TOOLS REQUIRED**

Wire Stripper  
Crimp Tool

**FASTENERS**

Crimp Terminals

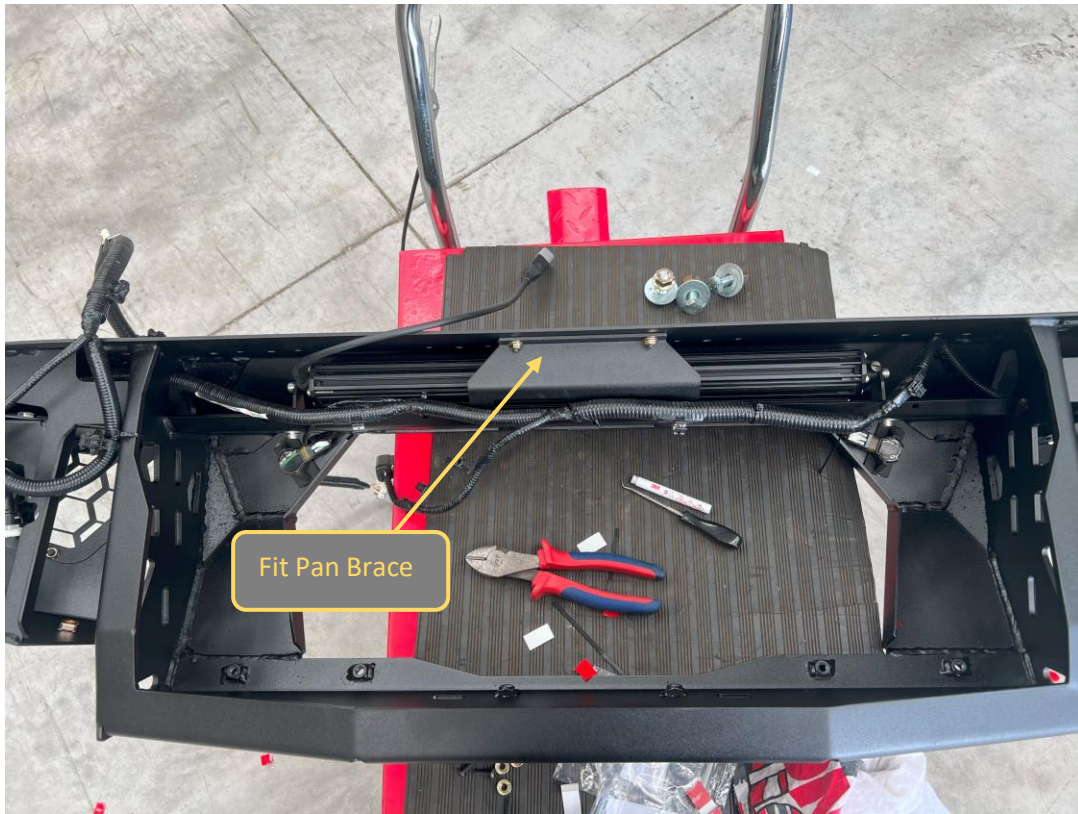

- 79. If fitting an integrated light bar, do so now.
- 80. The bar is designed to fit an Offroad Animal 22in or light bar. If fitting this light bar, assemble bar with legs out, and it will line up with the slots in the center gusset. Secure with Fasteners supplied with the light bar.
- 81. The bar can accommodate most other “20- 22inch” size light bars.
- 82. If fitting driving lights or top hoop to the bar this is also the most convenient time to do so. It is still possible later but is more difficult.
- 83. After fitting driving lights, fit the Pan brace to the back of the bar, between the pan and center gusset using Supplied M6x16 (top) and M6x12 bolts, Flat washers, and Flange Nuts
- 84. Continue to dry fit and optimize cable routes for center section.

**TOOLS REQUIRED**

4mm Allen Key  
**10mm Spanner / Socket**

**FASTENERS**

2x M6x16 BHCS – Black  
3x M6x12 BHCS  
5x M6 Flat Washer  
5x M6 Flange Nut



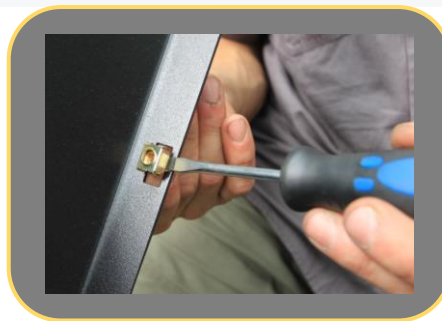
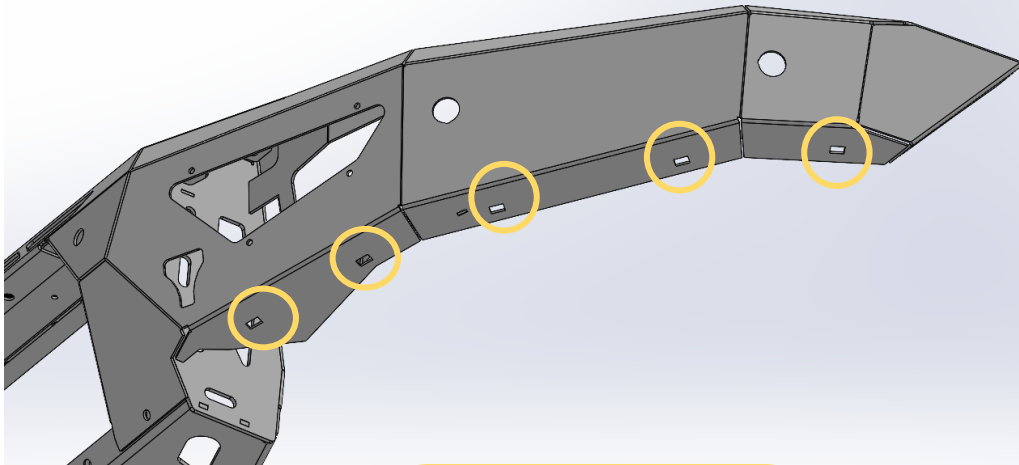

85. Fit 5x Cage nuts from small parts kit to rectangular slots in bottom of wing.

Use a small flat bladed screwdriver to push the edge of the cage to engage with the slot to aid fitting.

86. Repeat for other side of Bar

**TOOLS REQUIRED**

Small Flat Bladed Screwdriver

**FASTENERS**

5x M6 Cage Nut  
Per side

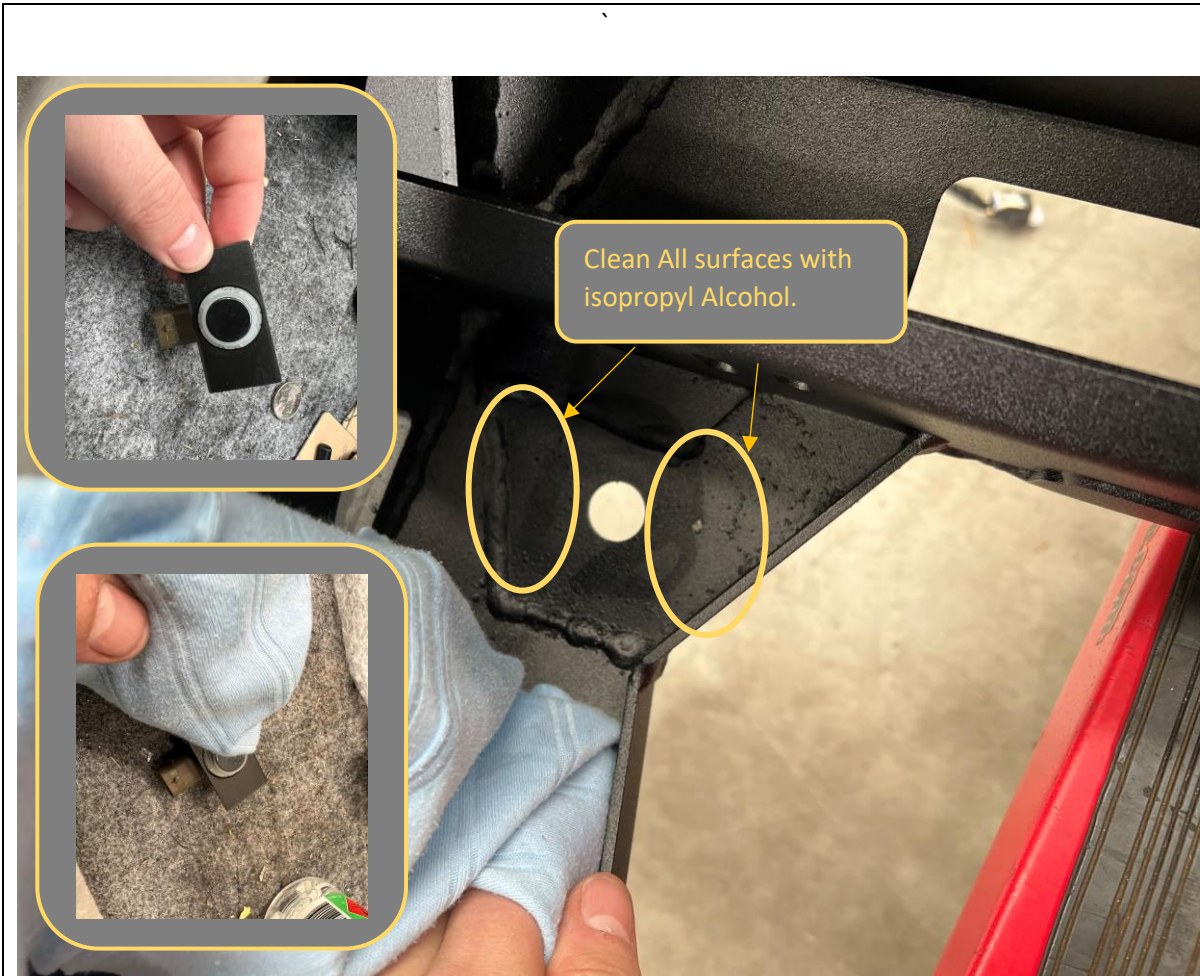

87. Re Fit parking sensors to the bar using the following procedure
88. Clean area on back side of bar adjacent to sensor holes with isopropyl alcohol.
89. Fit parking sensors to new supplied housings to help locate housing during adhesive process

**TOOLS REQUIRED**

Isopropyl Alcohol,  
Rag

**FASTENERS**

<p>Outer – F-0013L/R Horizontal Cable, Side Notch</p> <p>Mid – F-0011 Vertical Cable, Bottom Notch</p> <p>Inner – F-0010 Flat housing, Cable Angled to allow loom to fit.</p>	
<p>90. Check keying features on housings to ensure correct positioning of sensors.</p> <ul style="list-style-type: none"> <li>- Far outside – 1x Notch Side cable entry (handed)</li> <li>- Mid Outside – 1x Notch Top Entry</li> <li>- Inside – Flat (Angle is important, refer to test fitted orientation)</li> </ul> <p>Ensure loom positioning allows all sensors to sit in correct positions.</p>	<p><b>TOOLS REQUIRED</b></p>
<p><b>FASTENERS</b></p>	



91. Break the bulb of the supplied Primer 94 ampule to activate the primer dispensing.
92. Apply Primer 94 to all areas adjacent to the parking sensor locations, on both the bar and the sensor housings.
93. Apply supplied VHB tape pads to all sensor housings as shown in the inset photo.
94. Dry fit sensors to bar again to check loom position is correct. Connect all parking sensor loom connectors.
95. Remove backing and adhere sensors in position in bar. Apply pressure for 10-30sec after positioning for best adhesion.

**TOOLS REQUIRED**

**FASTENERS**  
VHB Tape pads  
Primer 94 Ampule

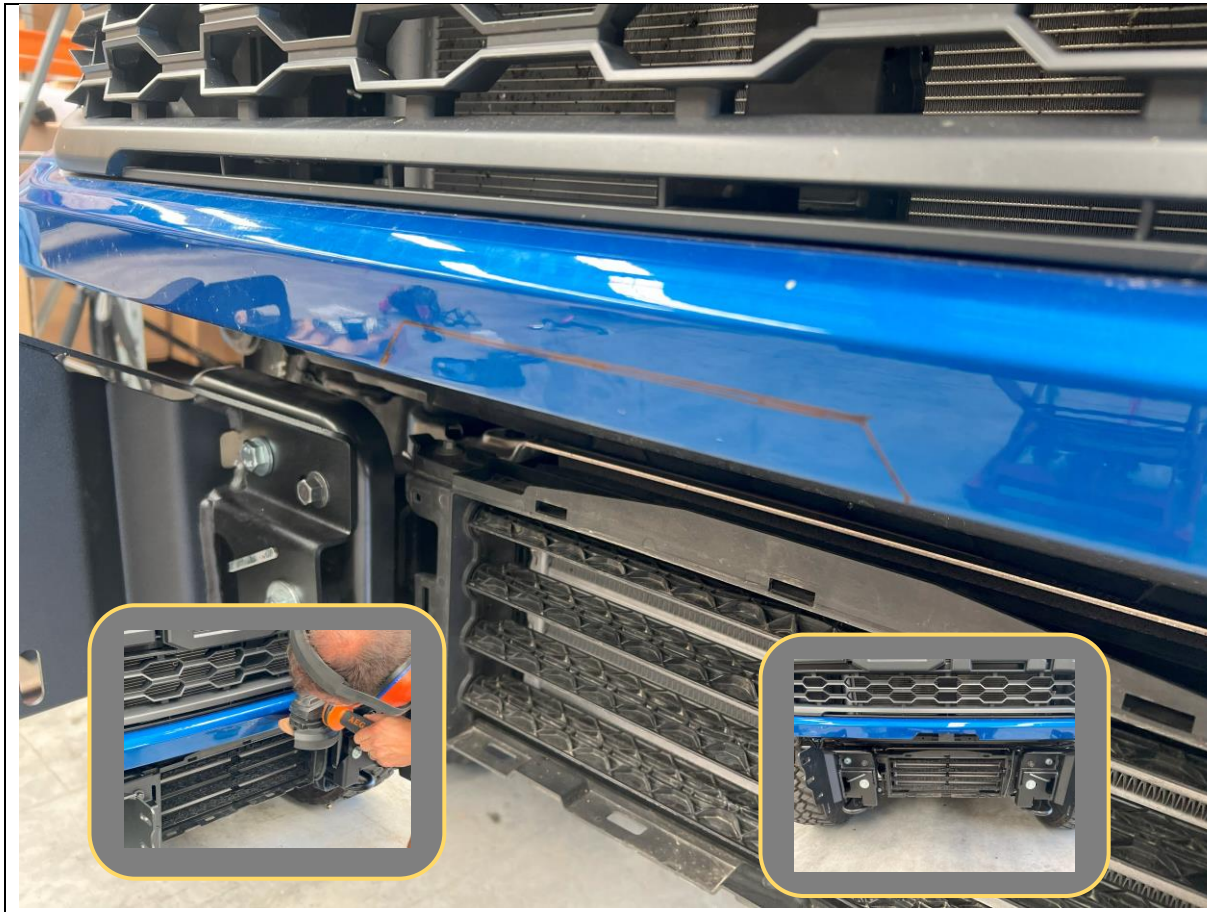

- 96. If fitting a winch with a large integrated control pack (Such as Warn Zeon), a small trim may be required to the plastic upper bumper.
- 97. Before the bar is fitted Place the winch in the cradle and offer up to the car to determine the clearance required and mark up the shape of the required trim. Many winches will clear and not require a cut.
- 98. If required, complete the trim using Angle grinder or oscillating multi tool.

**TOOLS REQUIRED**

Lifting Trolley  
Marker  
Angle Grinder  
or  
Oscillating Multi Tool

**FASTENERS**

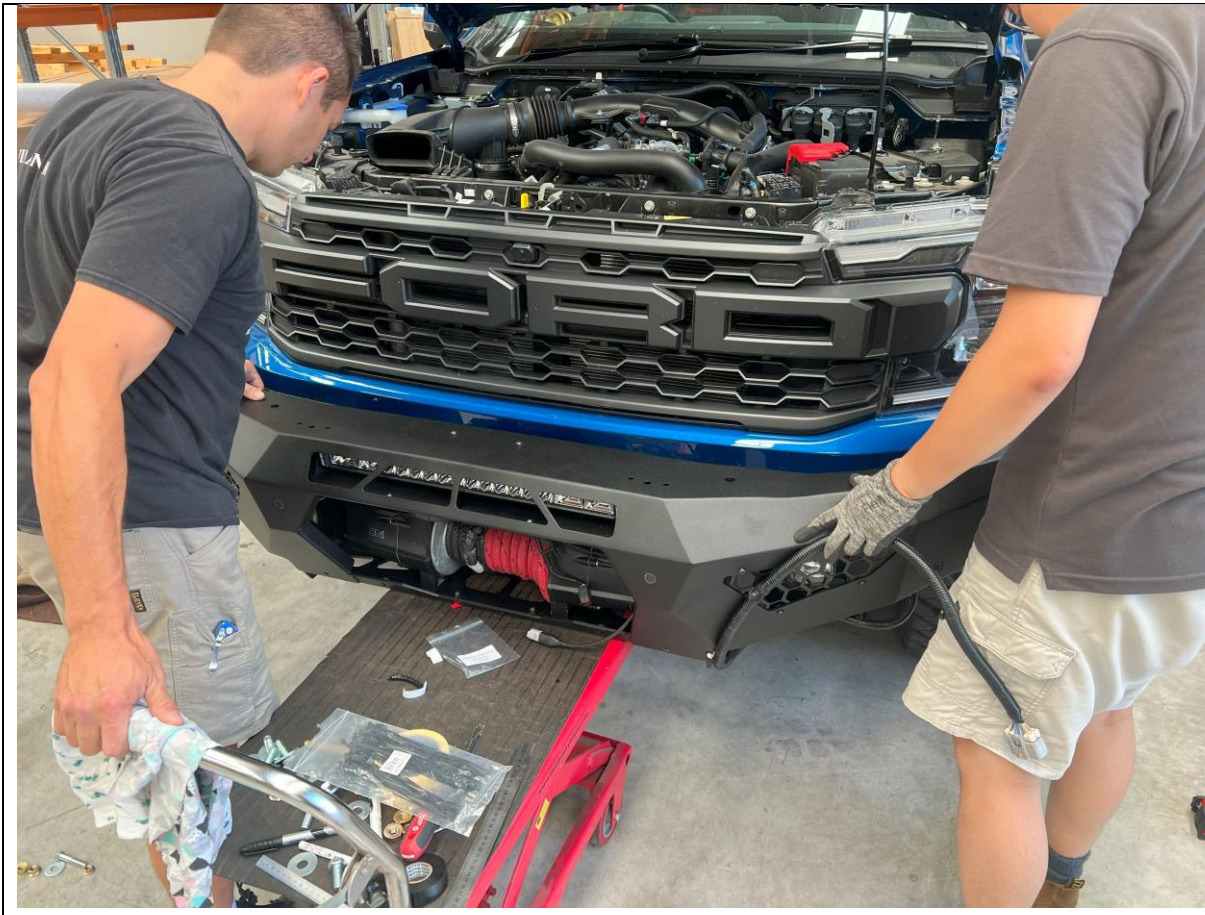

99. With assistance, either from another person, or a lifting trolley, lift the bar onto the mounts on the vehicle.
100. As the bar is fitted briefly unsecure the grille and pass through the wiring harness into its original position
101. Secure with 4x M12x30 Bolts, Heavy Duty washers and M12 Nyloc and Flange Nuts per side, Finger tight at this stage.

**TOOLS REQUIRED**

Lifting Trolley

**FASTENERS**

8x M12x30 Bolt  
12x M12 Heavy Duty Large Washer  
2x M12 Nyloc Nut  
12x M12 Flange Nut



102. With assistance, from another person, Align the bar with the edges of the vehicle. Adjust such that the clearances are neat and even side to side.

Acceptable range of clearances shown in image above.

103. Once in position tighten the M12 Bolts using socket and spanner. An impact driver may be used to speed up this process.

**TOOLS REQUIRED**

Lifting Trolley  
18/ 19mm Socket and Spanner

**FASTENERS**



- 104. If fitting a winch, do so now.
- 105. Some winches with integrated control box may require upper bumper to be trimmed, as per previous mention in step 96.
- 106. The bar is designed to fit most low mount winches, in foot down configuration. WARN ZEON 12 is largest winch confirmed to fit (with upper bumper trim).
- 107. The control box can be mounted on top of the winch. Winches usually come with a bracket to allow this. Refer to winch manufacturer.
- 108. Ensure clutch handle will be accessible through access hole in front mesh panel. Refer to winch instructions regarding changing clutch handle location.

**TOOLS REQUIRED**

Refer to winch fitting instructions

**FASTENERS**

Supplied with winch





109. Remove the radar module from the factory bracket by unclipping from the 3x Ball end studs.
110. Fit the radar module to the Radar support plate and radar cover panel using M6x30 Black Button Head Bolts, Flat Washers, and Flange Nuts.
111. Fit the top bolt first. Place 2x Extra Flat washers between the U Bracket and radar module to maintain factory inclination of radar unit.

**TOOLS REQUIRED**

10mm Spanner  
4mm Hex Key

**FASTENERS**

3x M6x30 Button Head  
3x M6 Flange Nut  
5xM6 Flat Washer

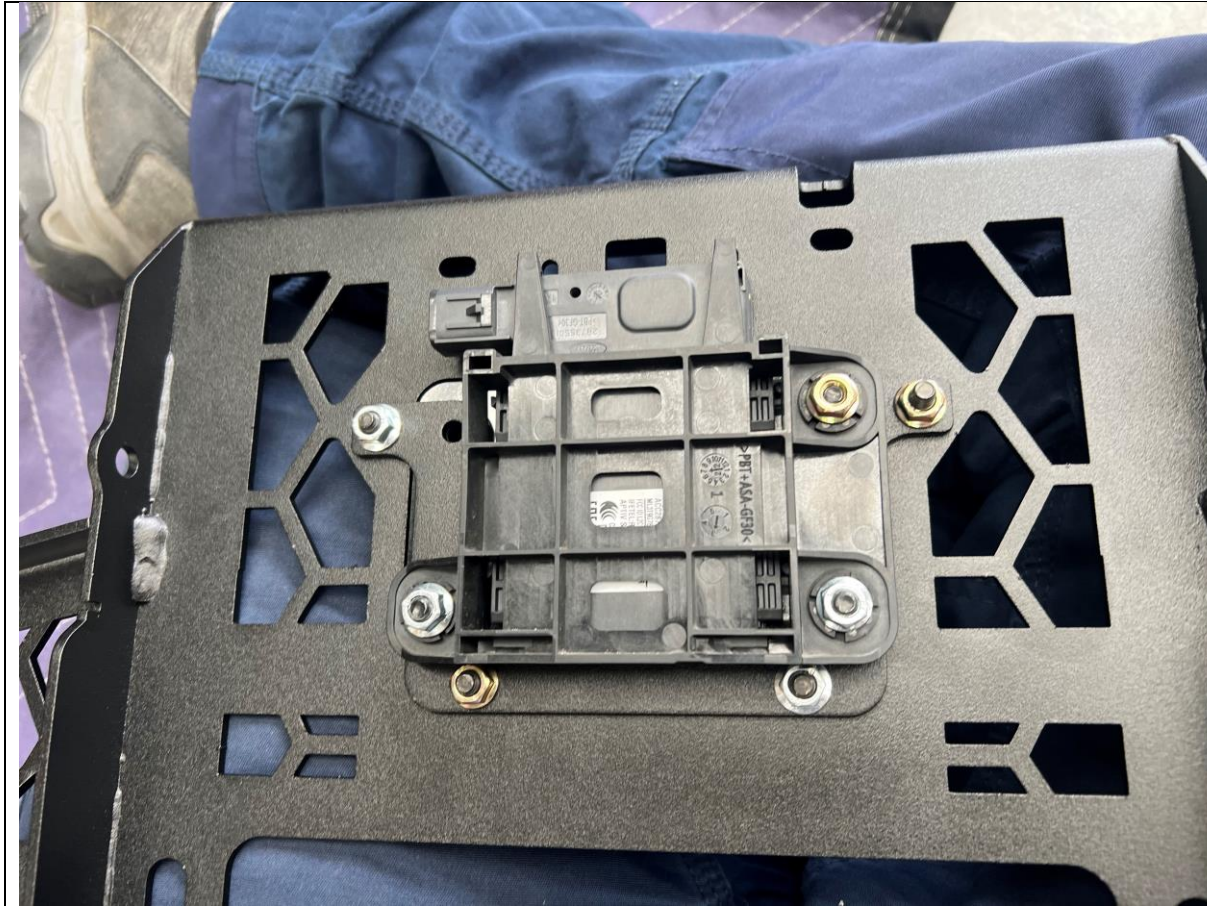

112. Fit the radar module on the support bracket to the main fairlead mesh panel using M6x16 Button head bolts, Flat washers, and flange nuts.
113. Fit M6x16 Button head, Flat washer and flange nut to final hole securing cover panel to radar bracket.

**TOOLS REQUIRED**

10mm Spanner  
4mm Hex Key

**FASTENERS**

5x M6x30 Button Head  
5x M6 Flange Nut  
5xM6 Flat Washer



114. If Required, Fit winch fairlead to Mesh Fairlead Mount. Use M10 or 3/8" Fasteners supplied with winch. The bar is only compatible with Hawse type fairleads.

115. Fit Number plate flip bracket to fairlead mount, M8x25 Bolt, Flat washer, Nylon washer and Nylon Lock nut. Ensure nylon washer sits between the bracket and fairlead mount.

**116. If Relocating Front Camera – Refit camera to mesh panel at this stage – Refer to Camera Relocation Kit instructions**

**TOOLS REQUIRED**

13mm Spanner  
10mm Spanner  
**4mm Hex Key**

**FASTENERS**

2x M8x16 Button Head  
2x M8x20 Hex Head  
2x M8 Flange Nut  
4xM8 Flat Washer



117. Fit the Mesh Fairlead Mount to the center of the bar, using M8x16 Button head (Top), M8x20 Hex (Bottom) M8 Flat washers and M8 Flange Nuts (Bottom Only).

118. Tighten fasteners using 13mm socket / spanner and 5mm Allen Wrench.

**TOOLS REQUIRED**

13mm Spanner  
5mm Allen Wrench

**FASTENERS**

2x M8x16 Button Head  
2x M8x20 Hex Head  
2x M8 Flange Nut  
4xM8 Flat Washer



119. Re Connect Electrical Harness, camera plug and camera washer hose.

120. Replace upper radiator cowl using original clips.

**TOOLS REQUIRED**

**FASTENERS**

Factory clips (re-use)



121. Connect the indicator wiring connectors fitted earlier.

122. Test indicators using the hazard lamp function.

**TOOLS REQUIRED**

**FASTENERS**



123. Before fitting the upper center bash plate to the vehicle, secure the Air guide to the bash plate using 3xM6X16 BHCS, Flat washers and Flange Nuts (see inset).

124. Fit 3x M8 Cage Nuts to the square slots on the bottom edge of the upper center bash plate.

125. Fit Upper Center Bash Plate using, M8x20 button head, flat washers.

126. Secure Bottom of Upper Center Bash Plate to mount on impact assembly using supplied M10x25 Button head, backed by a supplied M10 Flange Nut.

127. Tighten Bottom fasteners using 6mm Hex key

128. Tighten front fasteners using 5mm Hex key.

**TOOLS REQUIRED**

10, 13 mm Spanner  
**5 mm Allen Wrench**

**FASTENERS**

4x M8x20 Button Head  
4xM8 Flat Washer  
2x M10x25 Button Head  
2xM10 Flat Washer  
2xM10 Flange Nut  
3x M6x16 Black BHCS  
3xM6 Black Flat Washer  
3x M6 Flange Nut

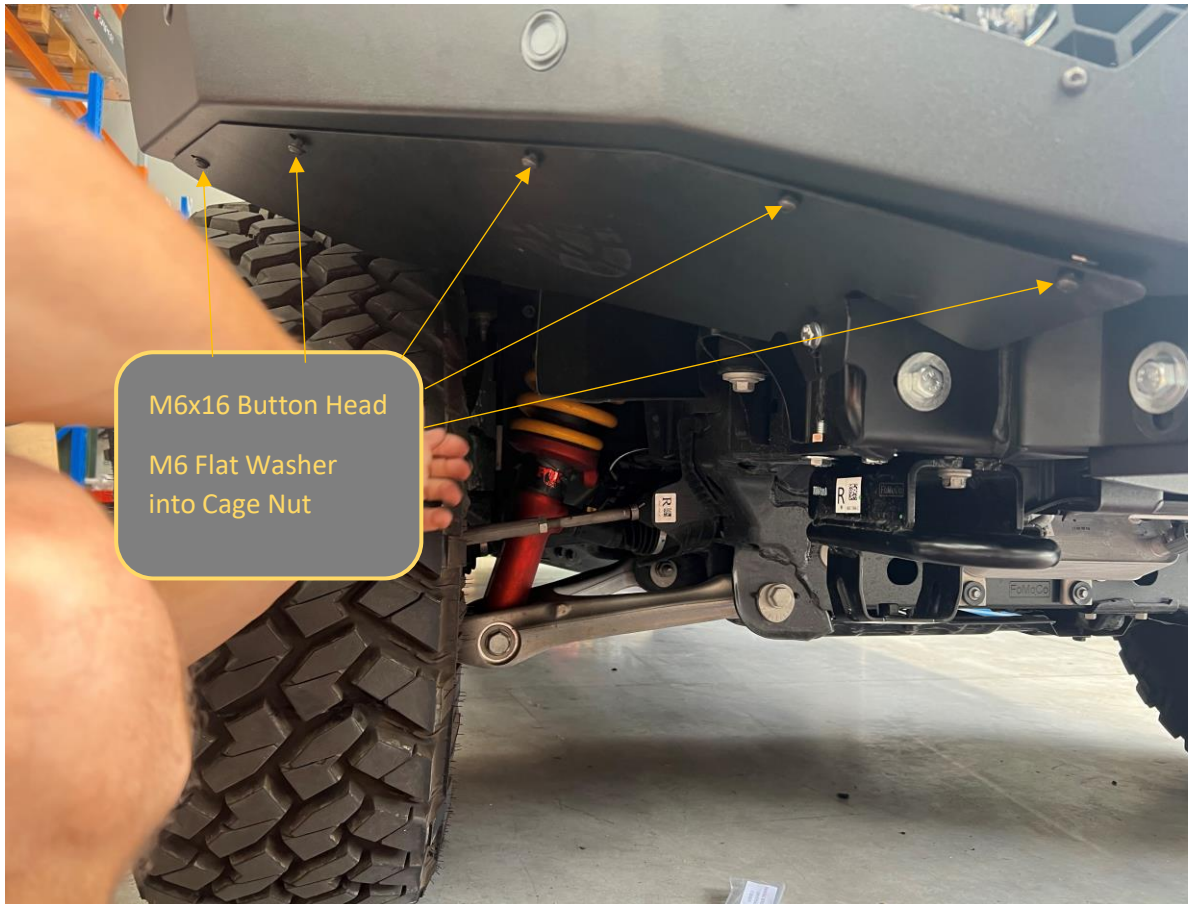

- 129. Fit Side Under panels using, M6x16 button head and flat washer into the cage nuts placed earlier.
- 130. Tighten with 4mm Allen wrench
- 131. Secure back of side under panel to tow point using M8x20 Hex Bolt, Flat washer, and M8 Flange Nut.
- 132. Leave finger Tight at this stage

**TOOLS REQUIRED**

**FASTENERS**

- 10x M6x16 Button Head
- 10x M6 Flat Washer
- 2x M8x25 Hex Head
- 2x M8 Flange Nut
- 2x M8 Flat Washer



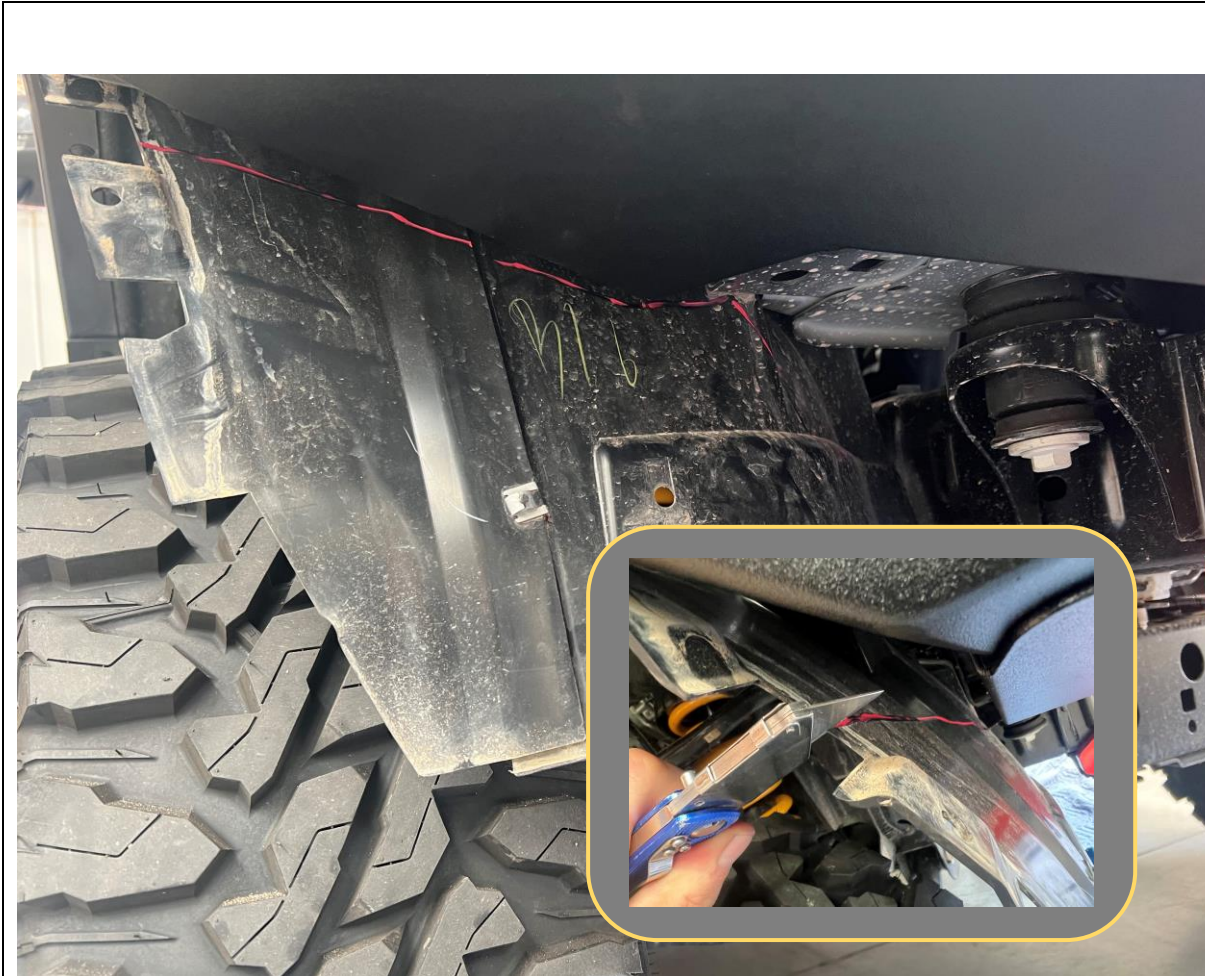

133. Using the edge of the under panel as a guide mark the wheel arch liner, approximately 20-25mm beyond the intersection of the under panel.

134. Cut along line as marked using utility Knife

135. Tuck the wheel arch liner behind the flange on the under panel

136. Tighten all under panel bolts

137. Complete for other side of vehicle.

**TOOLS REQUIRED**

Utility Knife  
13mm Spanner  
5mm Allen Wrench  
4mm Allen Wrench

**FASTENERS**

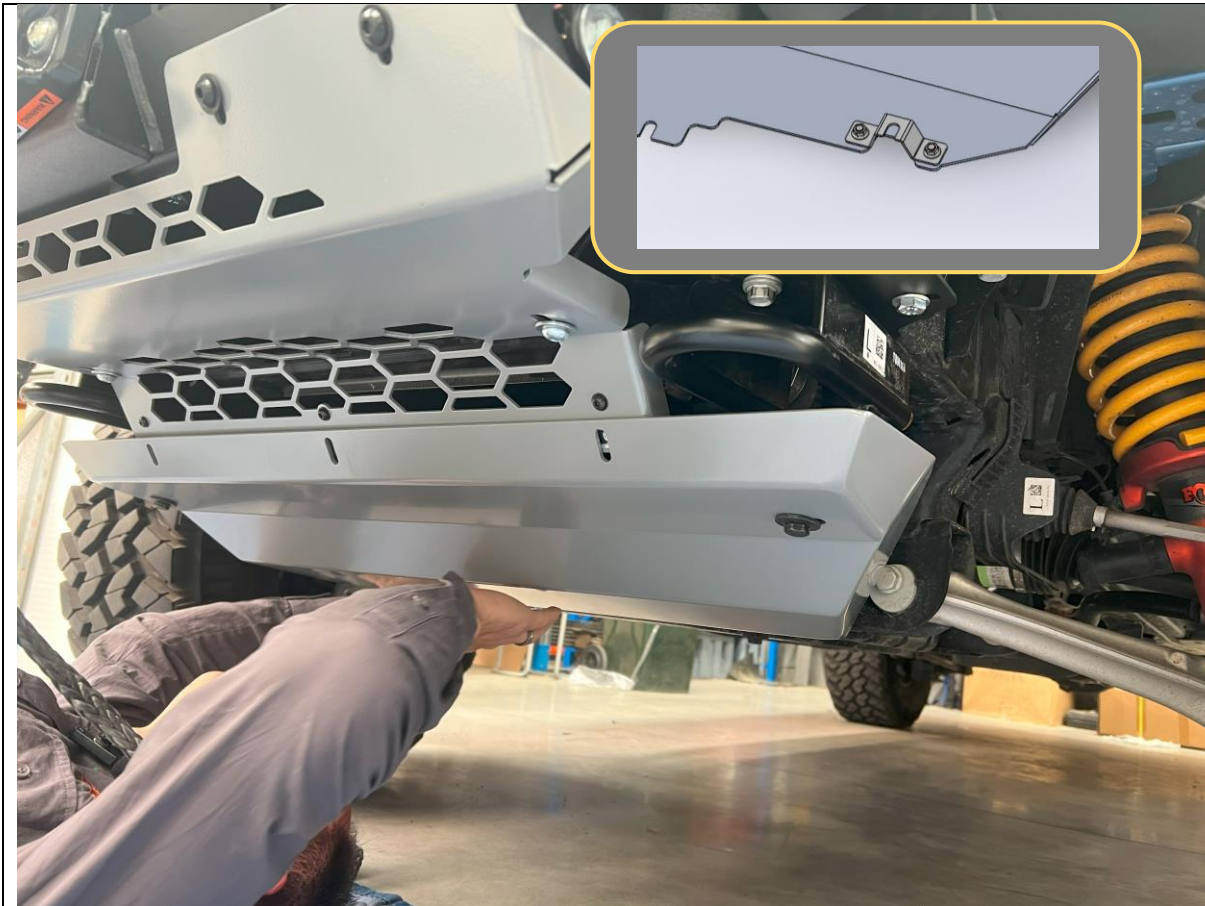

- 138. Fit the Lower center bash plate support bracket to the lower bash plate using the supplied M10x20 Button head fasteners.
- 139. Start Installing the lower bash plate by sliding over factory bolts on the engine crossmember.
- 140. Secure to tow points using Factory bolts
- 141. Secure to Upper center bash plate using 3x M8x20 Black Button head bolts and flat washers into the M8 Cage nuts fitter earlier.
- 142. Tighten all fasteners.

**TOOLS REQUIRED**  
15mm Spanner / Socket  
5mm Allen Wrench  
6mm Allen Wrench

**FASTENERS**

3x M8x20 BHCS Black  
3x M8 Black Washer  
2x M10x20 BHCS  
2x M10 Flat Washer  
2x M10 Flange Nut



143. If required, fit antenna to brackets, then bolt to the threaded inserts behind bar upright using M8x20 Button Head bolts and Flat Washers.

144. Tighten with 5mm Allen wrench.

145. If not fitting antenna brackets retain and supply to customer for future use.

**TOOLS REQUIRED**

5mm allen wrench

**FASTENERS**

2x M8x20 Button Head Bolt  
2xM8 Flat Washer



146. Check all Fasteners are tight.
147. **If Relocating Front Camera – Complete camera relocation steps - Refer to Camera Relocation Kit instructions**
148. Re-Fit number plate to number plate flip.
149. Head Bush and Enjoy your newly protected Raptor!

**For contact details see [www.offroadanimal.com](http://www.offroadanimal.com)**