



ISUZU DMAX MY2021 ON PREDATOR & TORO FRONT BAR

IMPORTANT! – READ BEFORE INSTALLATION

- When installed in accordance with these instructions, the front protection bar does not affect the operation of the vehicle's SRS airbags.
- This product must be installed exactly as per these instructions using only hardware supplied.
- Take a few moments to read instructions thoroughly before beginning work.
- In the event of damage to any bar component please contact OFFROAD ANIMAL to arrange repair/replacement of components.
- Do not use this product for any vehicle make or model other than that specified on these instructions.
- Do not remove labels from this product.
- This product and its fixings must not be modified in any way unless stated in these fitting instructions.
- The installation of this product is recommended for trained personnel.
- These instructions are correct at time of publication. OFFROAD ANIMAL cannot be held responsible for the impact of any changes subsequently made by the vehicle manufacturer. If you find something has changed please contact us to let us know!
- During installation it is the duty of the installer to check correct operation/clearances of all components.
- If Instructions are to be printed for reference in the workshop, it is recommended that they are printed in colour, for best legibility.

PARTS LISTING

IMPORTANT: Check all parts are present before beginning work! Contact OFFROAD ANIMAL if something is missing.

Main Parts – In the Box

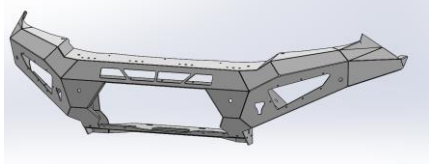
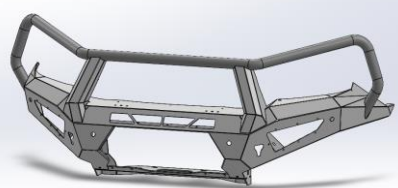
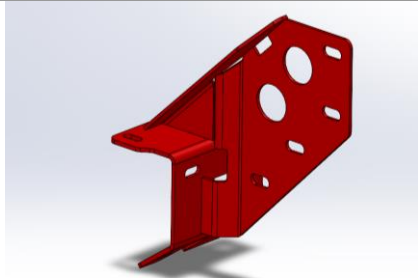
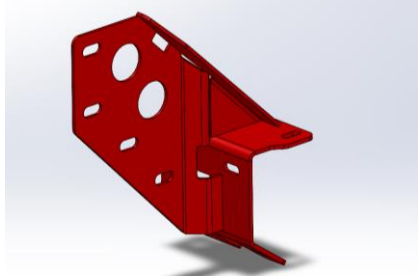
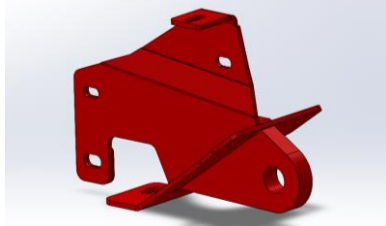
Qty	Part Number	Description	Image
1	FB-IDM-RG-21-PR-ASM1	ISUZU DMAX 21+ PREDATOR WELDMENT	
Or			
1	FB-IDM-RG-21-TOR-ASM1	ISUZU DMAX 21+ TORO WELDMENT	
1	FB-IDM-RG-21-PR-ASM2R	DMAX IMPACT ASSY	
1	FB-IDM-RG-21-PR-ASM2L	DMAX IMPACT ASSY	
1	FB-IDM-RG-21-PR-ASM3R	ISUZU DMAX 21+ TOW POINT ASSY	

1	FB-IDM-RG-21-PR-ASM3L	ISUZU DMAX 21+ TOW POINT ASSY	
1	U-0036	Isuzu DMAX 2021+ Predator Bash Plate	
1	U-0041	DMAX 21+ Supplementary Underpanel	
1	U-0037L	Isuzu DMAX 2021+ Predator Side Underpanel	
1	U-0037R	Isuzu DMAX 2021+ Predator Side Underpanel	
1	M-0014	DMax Predator Center Fairlead Mesh	
1	M-0015L	DMax Predator Side Mesh	

<p>1</p>	<p>M-0015R</p>	<p>DMax Predator Side Mesh</p>	
<p>1</p>	<p>B-0485R</p>	<p>Isuzu DMAX 2021+ Indicator/Fog Bracket</p>	
<p>1</p>	<p>B-0485L</p>	<p>Isuzu DMAX 2021+ Indicator/Fog Bracket</p>	
<p>1</p>	<p>M-0019R</p>	<p>Isuzu DMAX 2021+ Indicator/Fog Mesh Panel</p>	
<p>1</p>	<p>M-0019L</p>	<p>Isuzu DMAX 2021+ Indicator/Fog Mesh Panel</p>	
<p>1</p>	<p>B-0486R</p>	<p>Isuzu DMAX 2021+ Indicator/Fog infill</p>	
<p>1</p>	<p>B-0486L</p>	<p>Isuzu DMAX 2021+ Indicator/Fog infill</p>	

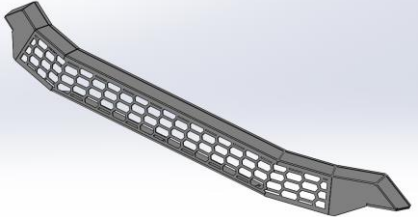
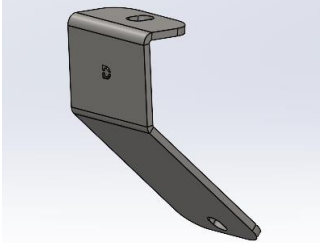
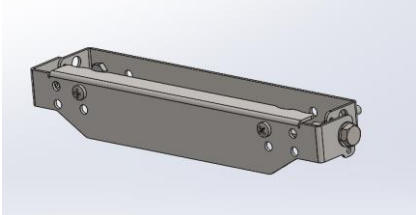
<p>1</p>	<p>B-0487</p>	<p>Isuzu DMAX 2021+ Mesh Grille Fill Panel</p>	
<p>1</p>	<p>B-1055</p>	<p>Isuzu DMAX 21+ Pan brace</p>	
<p>1</p>	<p>NPF-COM-SM- ASM0</p>	<p>Number plate flip asm Small</p>	

Small Parts – Contained in Small Parts Kit Bag

Qty	Part Number	Description
2	FB-IDM-RG-21-PR-ASM4	DMAX 21+ Tow Point Nut Plate
7	M10 FLANGE NUT	Flange Nut, M10x1.5 G8.8 ZP
11	M10 x 30	Bolt Hex, M10X30x[1.5], GR8.8 ZP
11	M10 Flat Washer	M10 FW
18	M12 FW LHD	M12 FW Large Heavy Duty
12	M12X30	Bolt Hex, M12X30x1.75, GR8.8 ZP
4	M12 FLANGE NUT	Flange Nut, M12x1.75 G8.8 ZP
6	M12 Nyloc nut	M12 NYLOC NUT
10	M8 FLAT WASHER- BLACK ZINC	M8 FW- BLACK ZINC
4	M8 X 16 BHCS BZP	SCREW, BUTTON HEAD CAP, M8X16X1.25 GR12.9 BLACK ZP
6	M8 X 20 BHCS BLACK ZINC	SCREW, BUTTON HEAD CAP, M8X20X1.25 BLACK ZP
10	M8 FLANGE NUT	Flange Nut, M8x1.25 G8.8 ZP
10	M6CN3MM	CAGE NUT M6x2.6-3.5
48	M6x16 BHCS BLACK ZINC	SCREW, BUTTON HEAD CAP, M6X16X1 GR12.9 BLACK ZP
48	M6 FLAT WASHER BLACK ZINC	M6 FW BLACK ZP
40	M6 FLANGE NUT	Flange Nut, M6x1 G8.8 ZP
2	M6 X 20 HEX	M6X20 HEX BOLT, ZP, 8.8
2	M6 FLAT WASHER	M6 FW
2	NP-COM-M10-190-ASM0	M10 LOLLYPOP NUT PLATE 190MM LONG
3	M5 FLANGE NUT	Flange Nut, M5x0.8 G8.8 ZP
3	M5 Flat washer	M5 FW
3	M5X15 BHCS	SCREW, BUTTON HEAD CAP, M5X15X0.8 GR12.9 ZP
4	M8 FLAT WASHER	M8 FW
4	M8 X 20 HEX	Bolt Hex, M8X20x1.25, GR8.8 ZP
2	B-0508	DMAX 21+ Headlight Securing Bracket

TORO EXTR Small Parts – IN ADDITION to PREDATOR Small Parts

Qty	Part Number	Description
2	B-0523	Toro Antenna Bracket - 90 Degree
4	M8 X 20 BHCS BLACK ZINC	SCREW, BUTTON HEAD CAP, M8X20X1.25, ISO4042 ZnNi BLACK PASSIVATED FINISH
4	M8 FLAT WASHER- BLACK ZINC	M8 FLAT WASHER, 16.5x8.4x1.2, ISO4042 ZnNi BLACK PASSIVATED FINISH

TOOLS REQUIRED

The following tools will be required to install the product.

Hand Tools	Power Tools	Workshop Equipment
Metric Socket Set 8-19mm Socket Extension Bar Metric Spanner Set 10-19mm Torx Drivers T25-T30 Hex (Allen) Key Set 4-6mm Trim Puller Tool Flat Blade Screwdriver set Phillips Head Screwdriver set Utility Knife Side Cutters Pliers	Electric Drill 6mm Drill Bit Air Hacksaw or Angle Grinder Electric/Air Impact Driver (Optional)	Panel Stand or Soft Blanket Cable Ties Masking Tape Black Automotive paint Scotch Brite or Fine Sandpaper Automotive Sealant/Adhesive Bucket Hose Clamp

WORKSHOP SAFETY

It is the responsibility of the installer to always complete works in a safe manner. Make sure the following safety equipment is available and precautions are observed whilst fitting this product.

<p>Hearing Protection</p> 	<p>Always wear ear protection when using power tools.</p>
<p>Eye Protection</p> 	<p>Ensure eye protection is always worn when cutting or drilling.</p>
<p>Manual Handling</p> 	<p>Do not attempt to lift bar assemblies or rock sliders on your own.</p> <p>Always use two people to lift or use mechanical lifting aid such as hydraulic lifting trolley.</p>
<p>Vehicle Support</p> 	<p>Always ensure vehicle is properly supported when working on it. Do not attempt to fit products whilst suspension work is being carried out. Do not work under a vehicle supported only by a jack.</p>

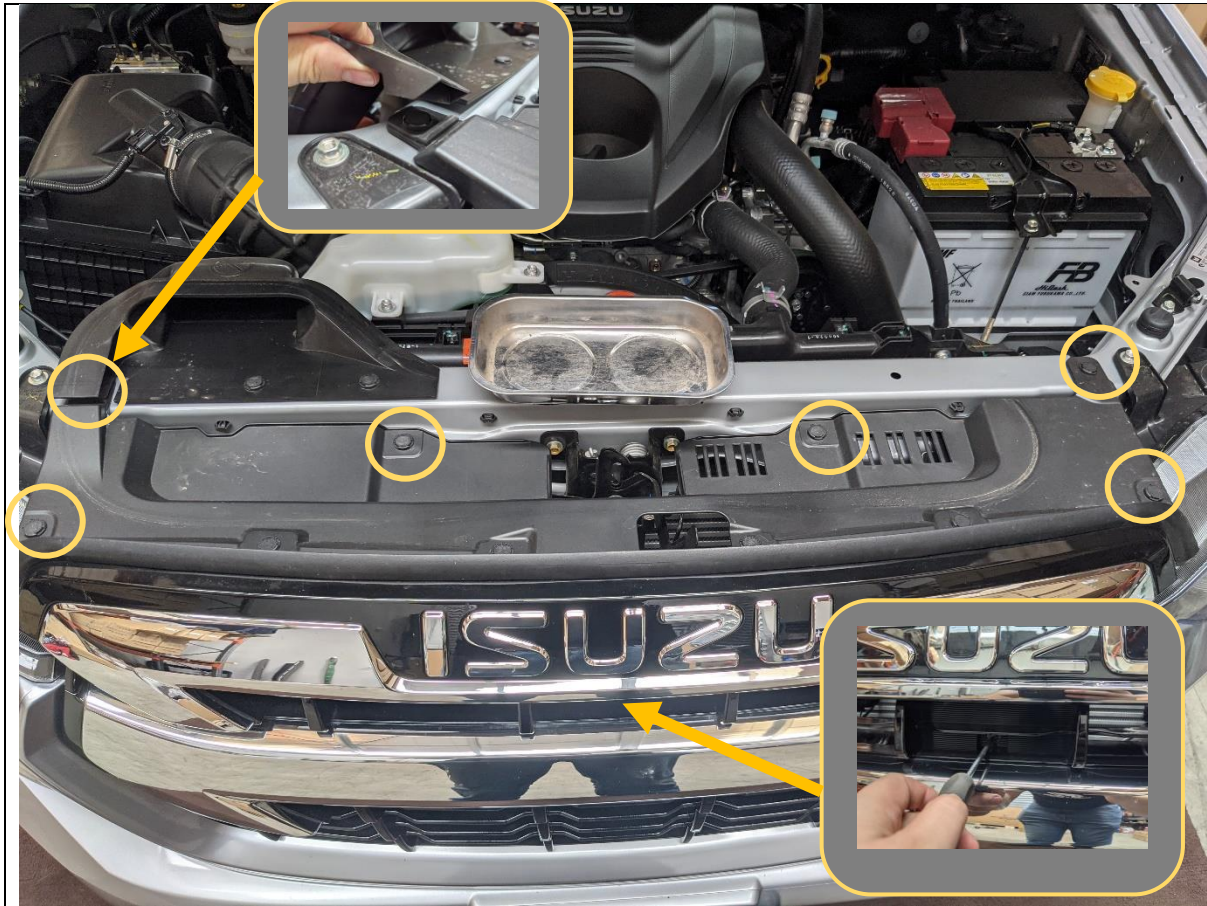

1. Open the Bonnet.
2. Remove the 4x Clips securing the top of the grille by levering up center part using small flat blade screwdriver
3. Remove phillips head screw securing bottom of grille underneath "ISUZU" badge.
4. Remove the top portion of the grille from the car

TOOLS REQUIRED
Small Flathead Screwdriver
Phillips Head screwdriver

FASTENERS
Retain Factory Clips and Screw



5. Remove the three screws securing the bottom edge of the bumper, using 10mm Socket / Spanner

TOOLS REQUIRED
10mm socket / spanner

FASTENERS



6. Remove the clips on the underside of the wheel arch by the bumper to quarter panel seam, and under the bottom of the bumper near wheel as shown.
7. Remove using same technique as other clips
8. Remove the 10mm nut securing bottom of bumper.
9. Repeat for other side of vehicle

TOOLS REQUIRED
10mm socket
Trim Tool

FASTENERS
Factory Clip and Nut

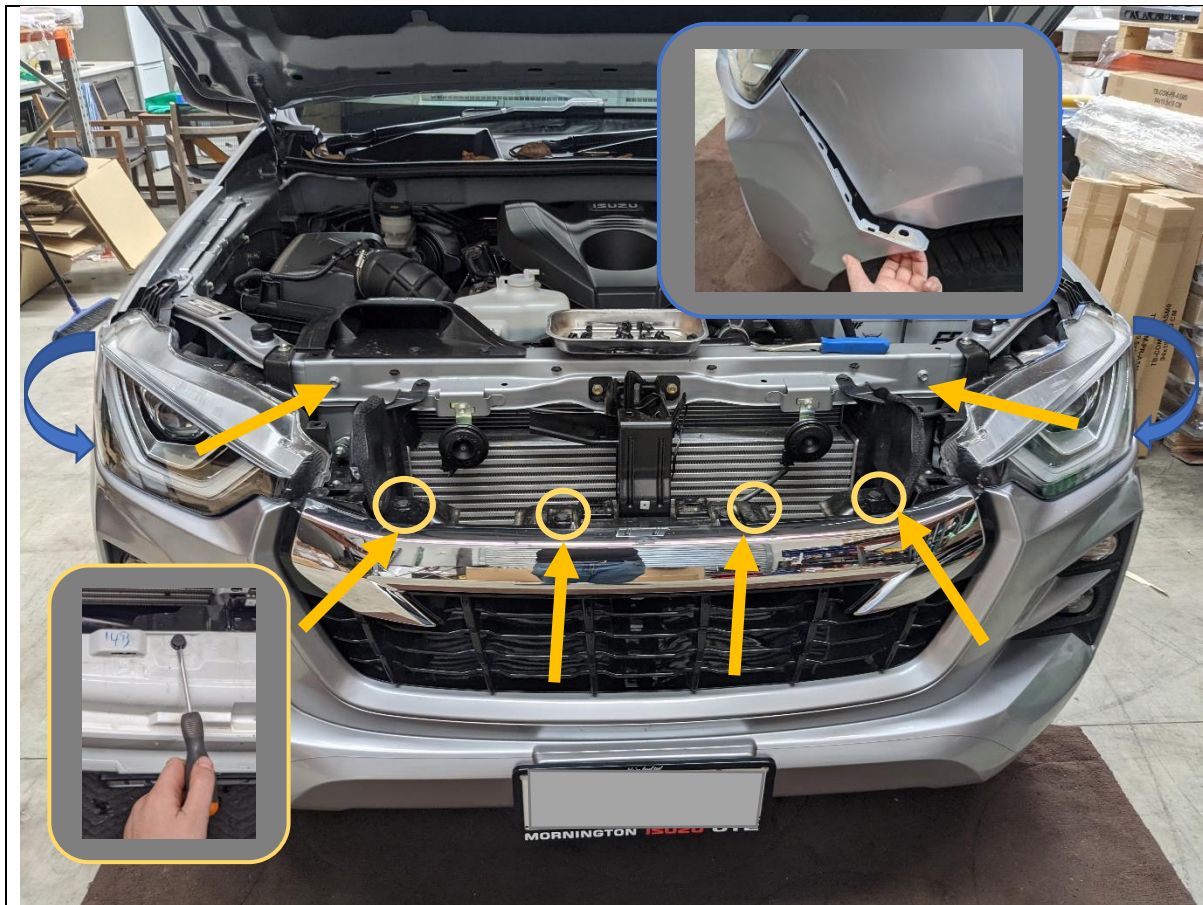

10. Remove the 4x clips securing the center of the bumper using small flat blade screwdriver to pry up the center section
11. Release the bumper clips by pulling bumper away from bottom of headlights, starting from the outside and working in.
12. When bumper is loose, reach in and disconnect the fog light wiring harness located under the left hand headlight.
13. Remove bumper from car and set aside on soft blanket or panel stand.

TOOLS REQUIRED

Small flat blade screwdriver

FASTENERS

Factory Clips

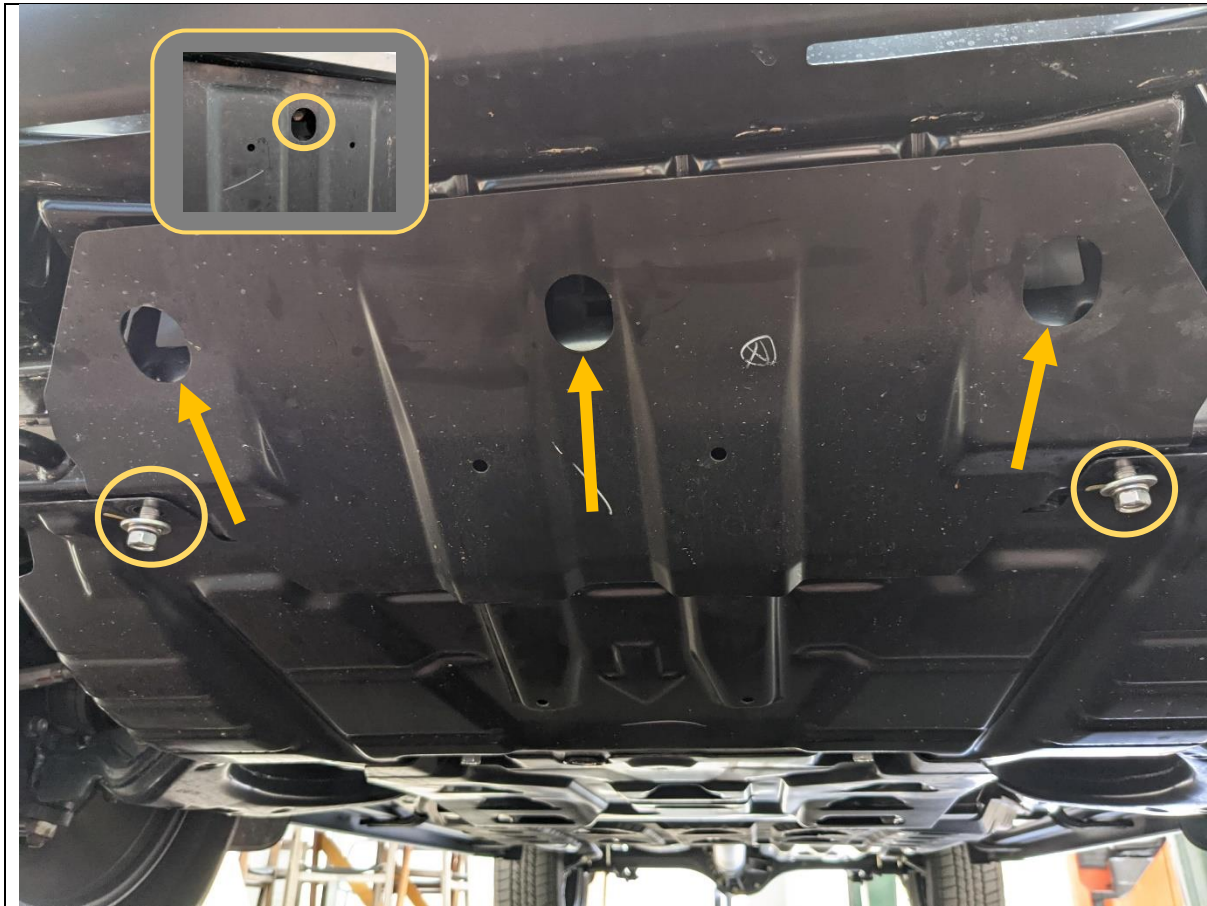

14. Remove the front skid plate by removing the 5x 14mm head bolts securing it to the chassis. Note 3x of the bolts are recessed into the skid plate, shown with arrows.

TOOLS REQUIRED

14mm socket
Short extension bar

FASTENERS

Factory 14mm head bolts.
Retain for refitment.

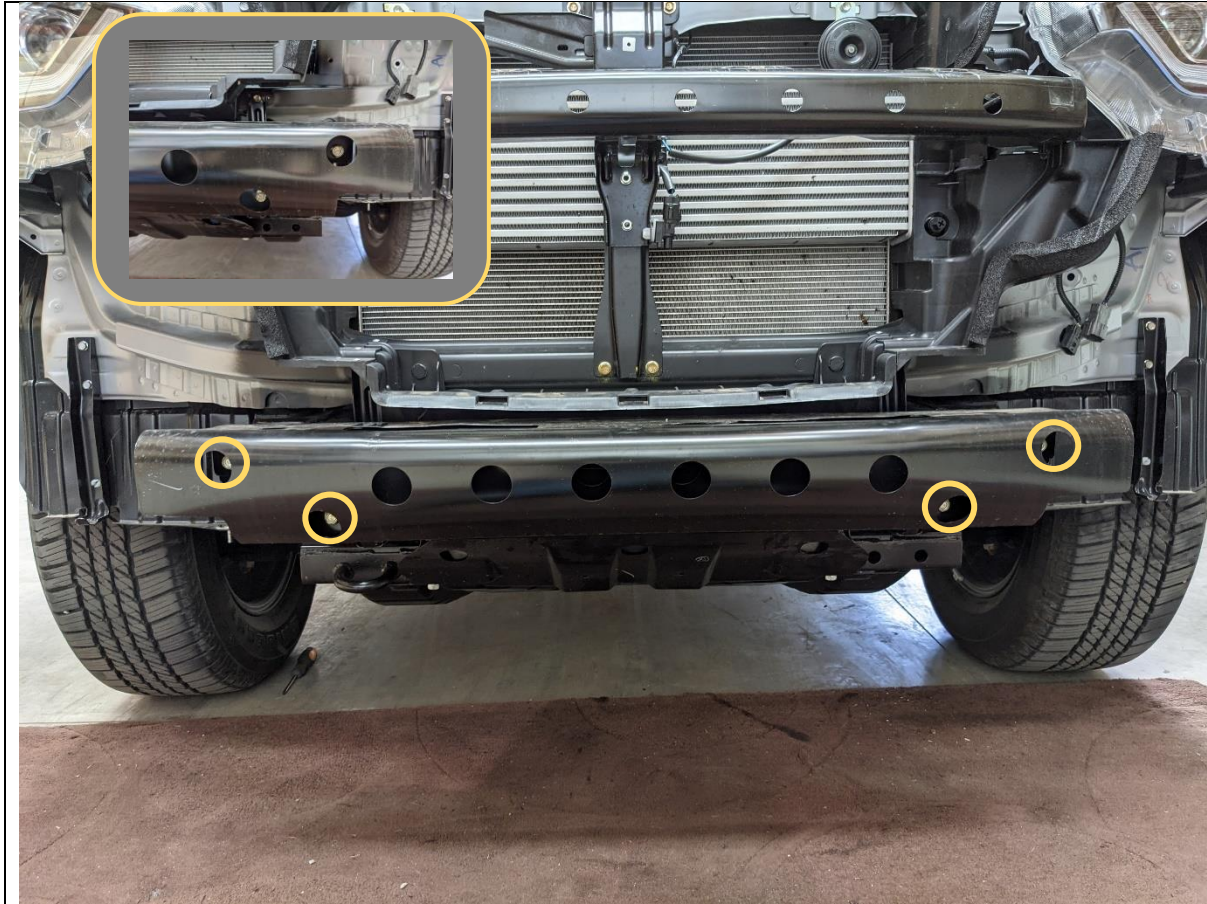

- 15. Remove the 4x 14mm head bolts that secure the impact beam to the chassis
- 16. Remove and discard the impact beam. Retain bolts for fitting of mount.

TOOLS REQUIRED
14mm socket

FASTENERS

Retain for re-fitment of mounts

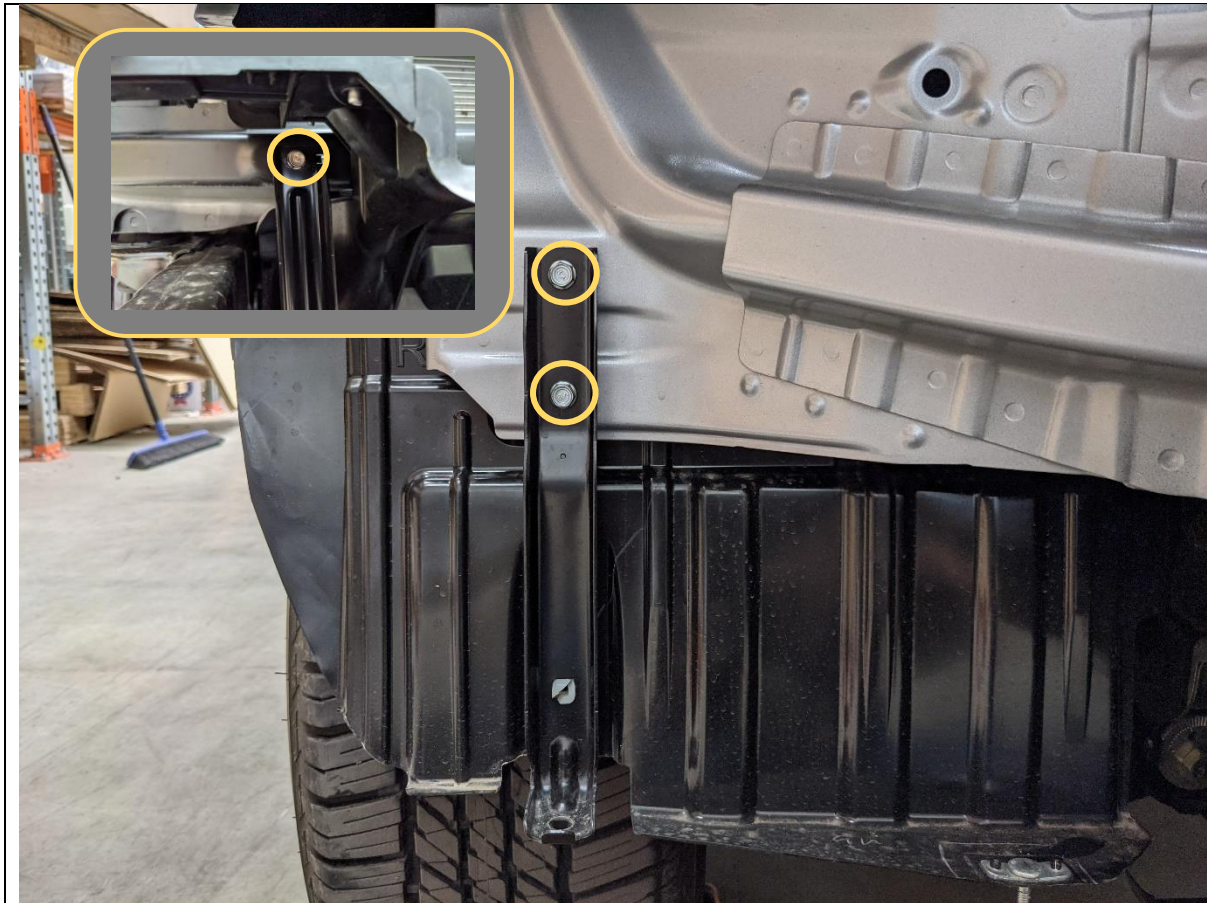

- 17. Remove the 10mm bolts securing the bottom bumper supports.
- 18. Remove and discard the bumper supports

TOOLS REQUIRED

10mm socket

FASTENERS

Factory 10mm head bolts
Discard

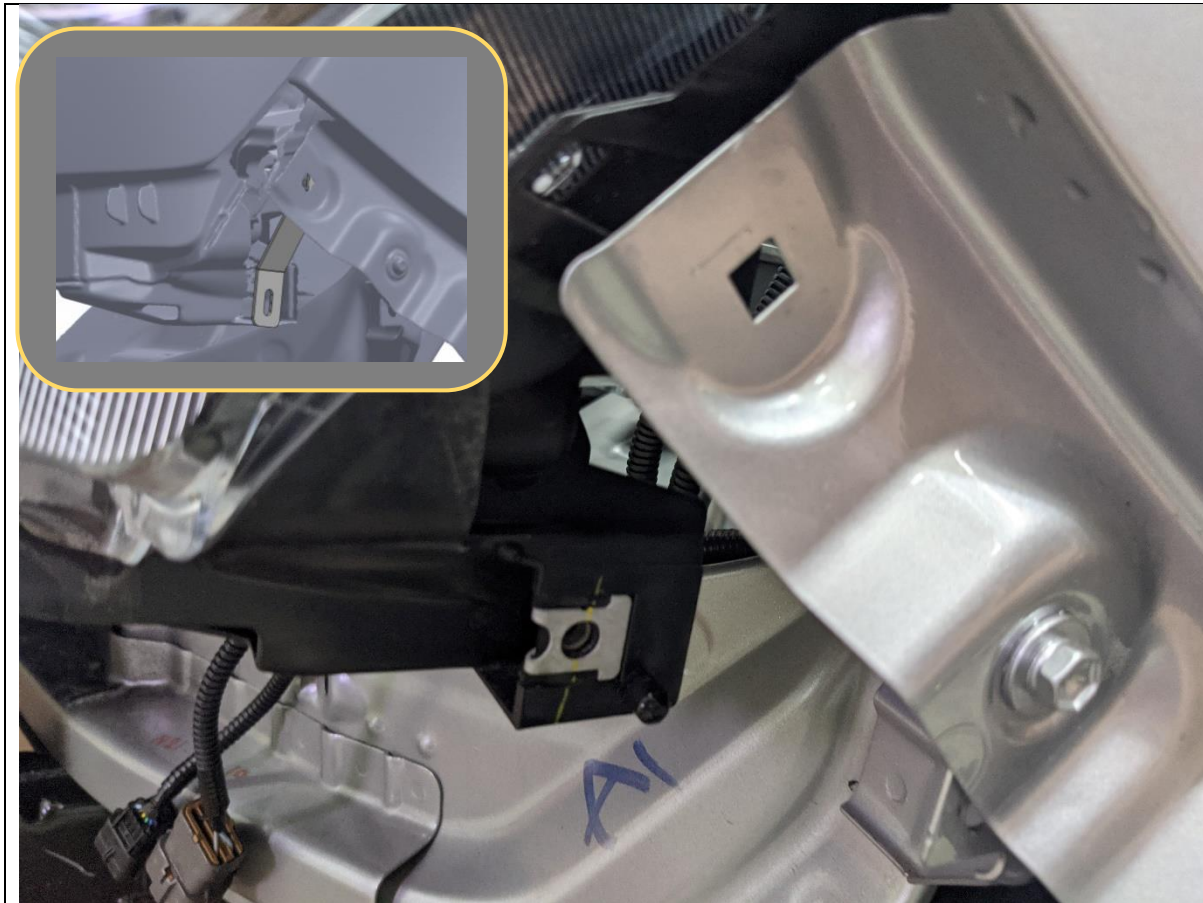

19. Remove the 10mm and Philips head screws securing the plastic bumper supports beside the headlights. Retain the screw that secures the bumper support to the headlight.
20. Remove the bumper supports, a firm tug will be required to release the clips. Discard
21. Fit the headlight support bracket between the fender and headlight. Re-use factory bolt to secure bracket to headlight and use M6x16 flat washer and flange nut to secure to fender.
22. Complete on both sides of vehicle

TOOLS REQUIRED

Phillips head screwdriver

FASTENERS

Factory Bolt.
1x M6x16 Button Head
1x M6 Flat Washer
1x M6 Flange Nut

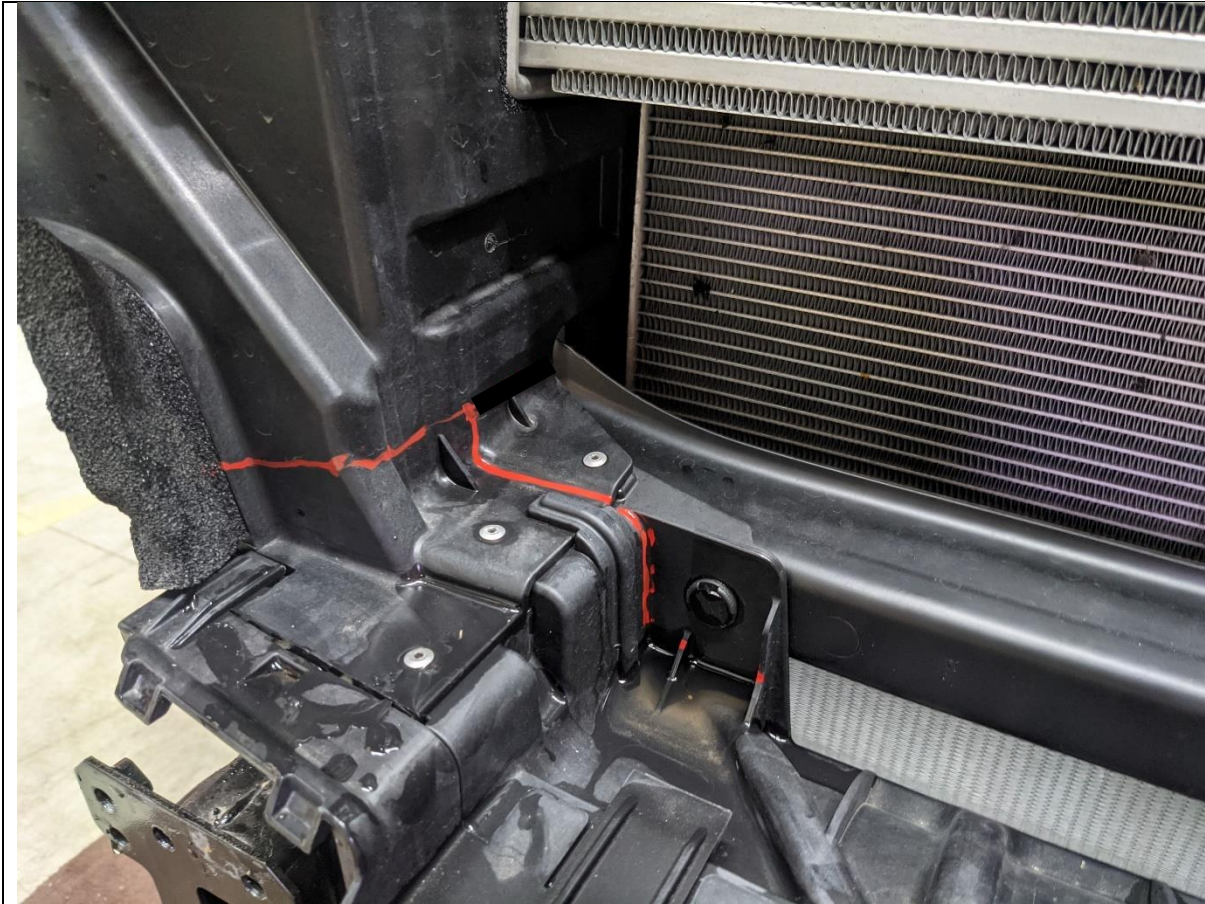

- 23. Trim the plastic air guide along the marking as shown.
- 24. It is easiest to remove the guide from the vehicle before trimming. Guide is secured with clips
- 25. Replace the top section of trimmed guide once cuts are completed.

TOOLS REQUIRED
Utility knife or
air hacksaw

FASTENERS



- 26. Unplug the electrical connectors from the fog light and indicators.
- 27. Remove the harness clips from the bumper using a trim tool.
- 28. Set aside harness for re-fitment to Offroad Animal Bar.
- 29. If equipped, remove the parking sensors and parking sensor harness from the bumper.

TOOLS REQUIRED
Trim Tools

FASTENERS

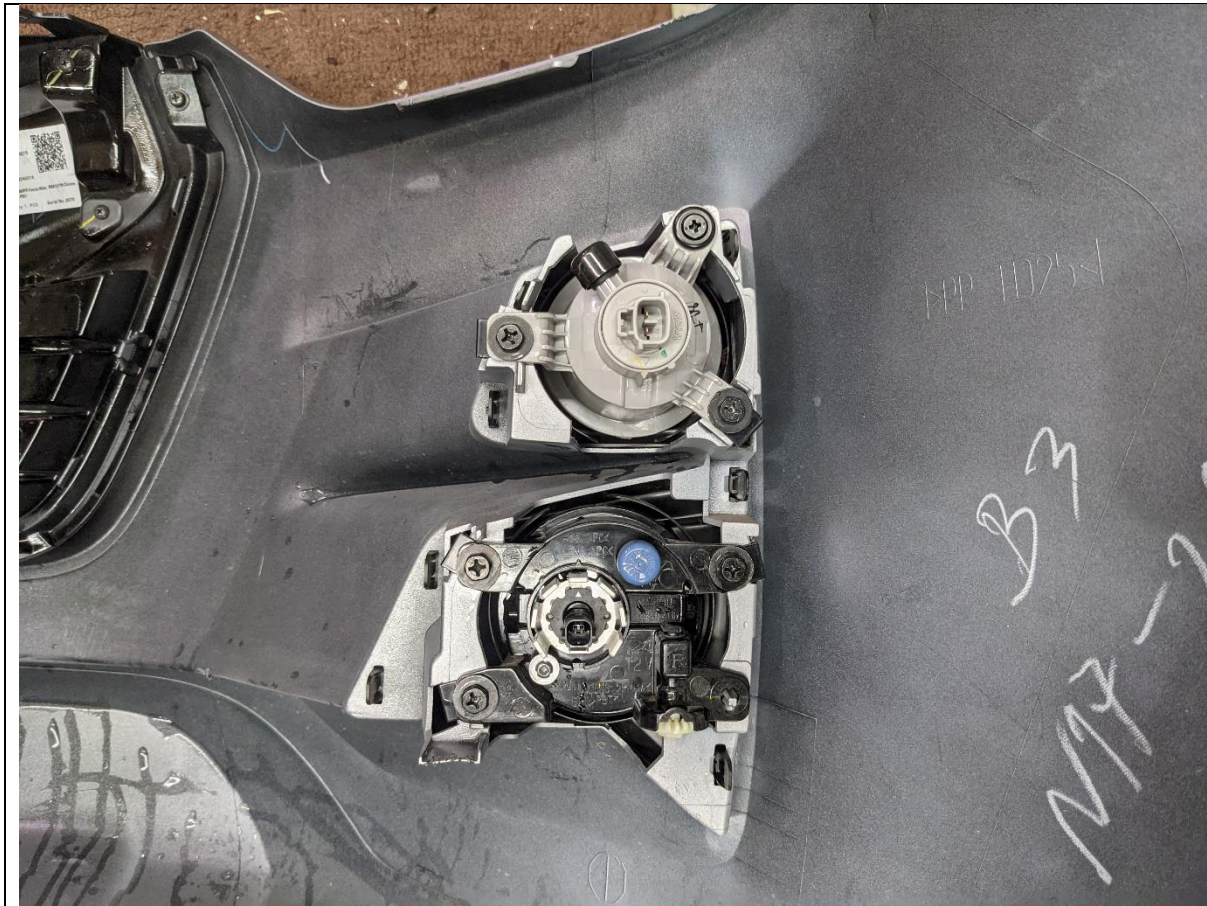

30. Remove the indicator and fog lights from the bumper using Phillips head screwdriver.

31. Discard the factory Philips head screws.

TOOLS REQUIRED
Phillips head screwdriver

FASTENERS
OE Philips head screws

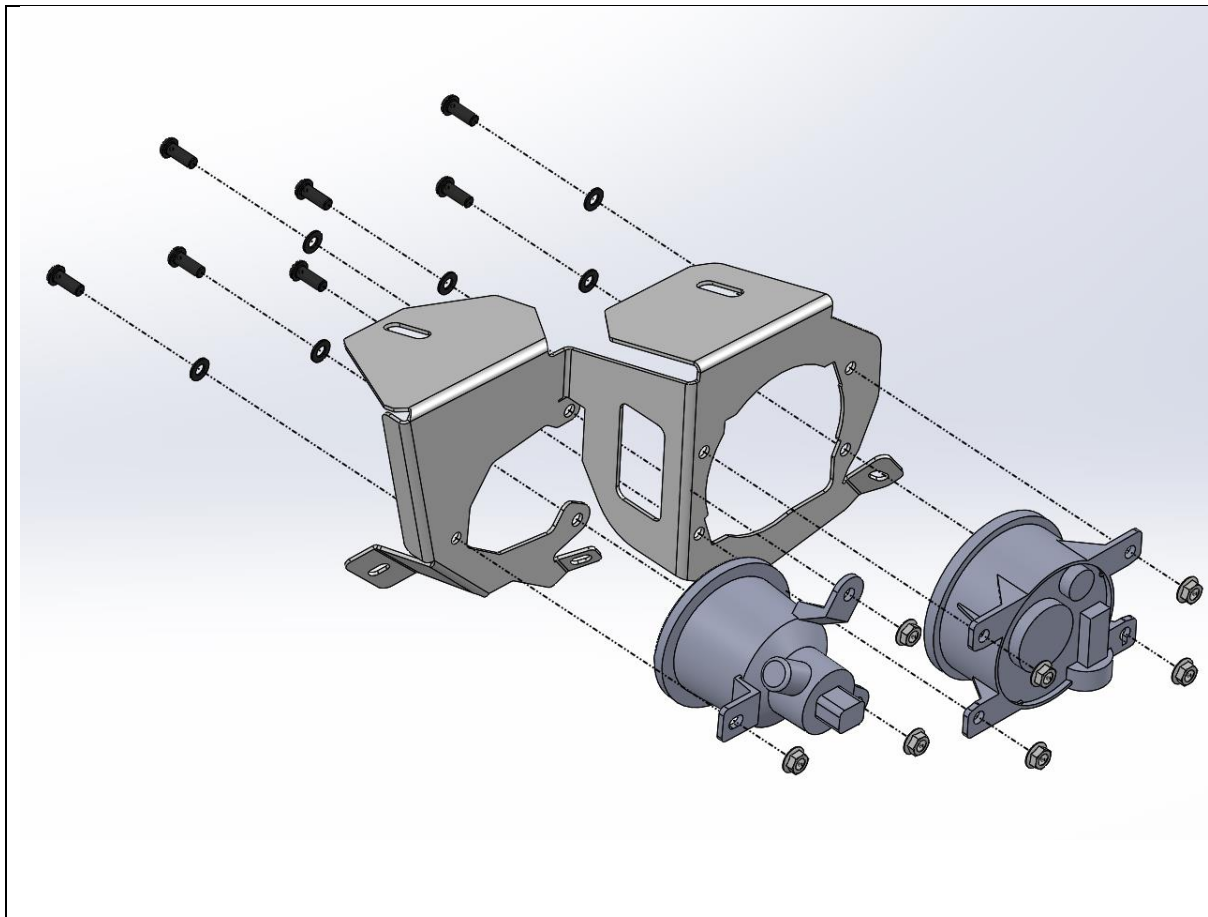

- 32. Fit the fog light and indicator to the light mounting bracket supplied in the kit using supplied M6x16 button head screws, flat washers, and flange nuts.
- 33. Lights sit on the back side of the bracket. Take care to ensure the correct handed lights are re-fitted.

TOOLS REQUIRED
4mm Allen Key

FASTENERS
7x M6x16 Button Head Screw
7x M6 Flat Washer
7x M6 Flange Nut

Per side

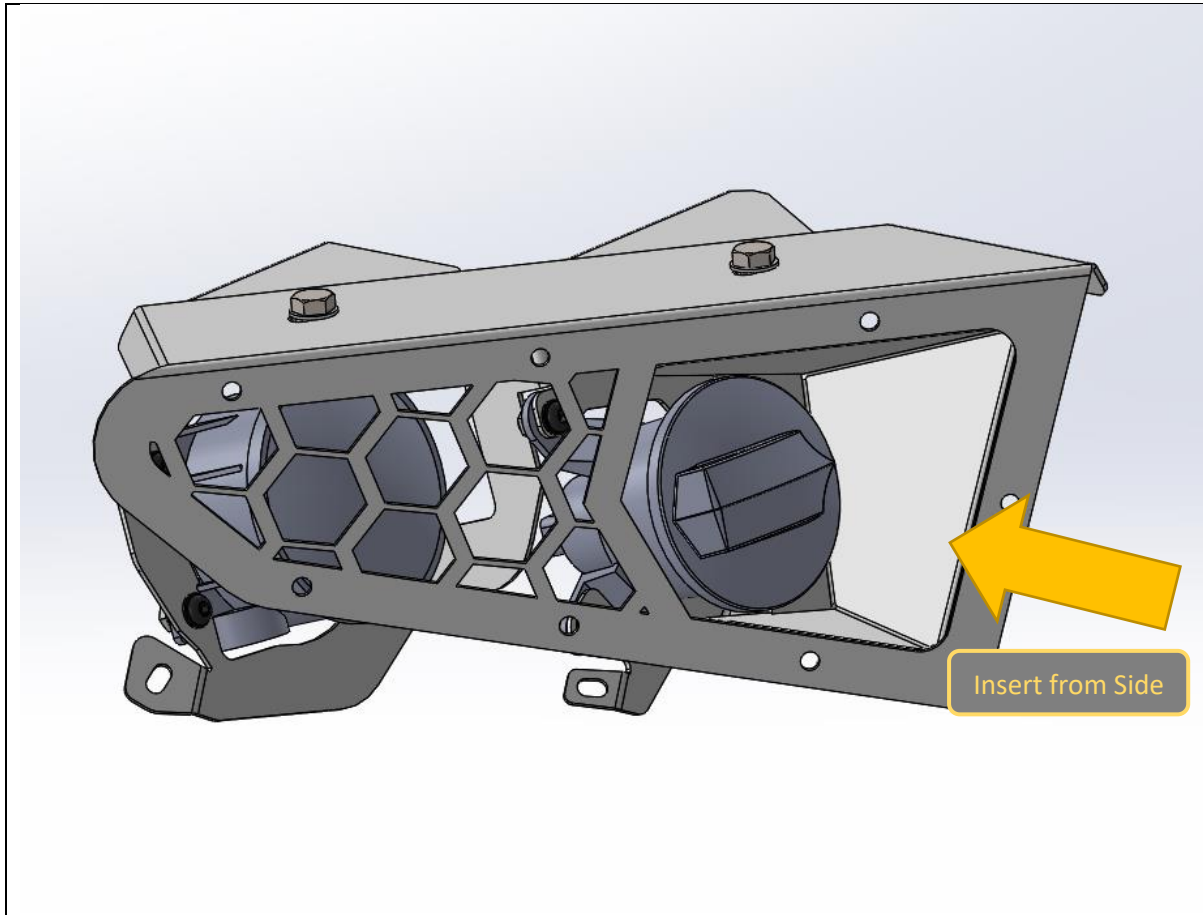

- 34. Fit the light bracket to the mesh cover panel using supplied M8x20 bolts, flat washers, and flange nuts.
- 35. As the light bracket is being positioned with the mesh panel, insert the indicator trim bracket in position between the indicator and the mesh panel, from the side.

TOOLS REQUIRED
13mm Spanner / Socket

FASTENERS
2x M8x20 Bolts,
2x M8 Flat washers
2x M8 Flange Nuts
Per Side

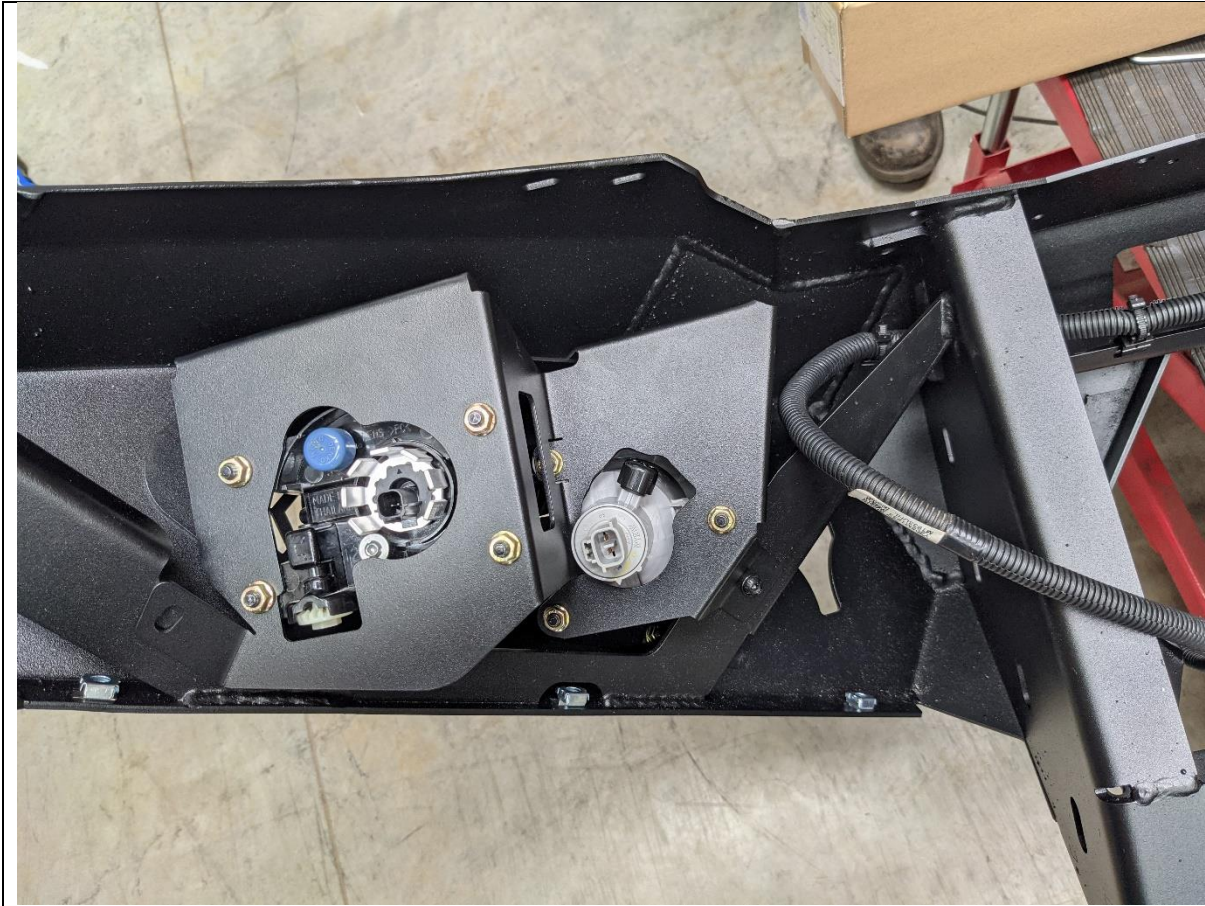

- 36. Insert the assembled light bracket / mesh panel into the wing of the bar.
- 37. Secure to wing brace with supplied M6x16 button head bolts, washers, and flange Nuts

TOOLS REQUIRED
4mm Hex Key

FASTENERS
2x M6x16 Button Head Screw
2x M6 Flat Washer
2x M6 Flange Nut

Per side



- 38. Secure to the wing of bar using with supplied M6x16 button head bolts, washers, and flange Nuts
- 39. Re install wiring harness to bar and plug in connectors for fog light and indicators
- 40. If equipped, re fit parking sensors to bar by relocating original housings to the holes on the bar.

TOOLS REQUIRED
4mm Hex Key

FASTENERS

7x M6x16 Button Head Screw
7x M6 Flat Washer
7x M6 Flange Nut

Per side

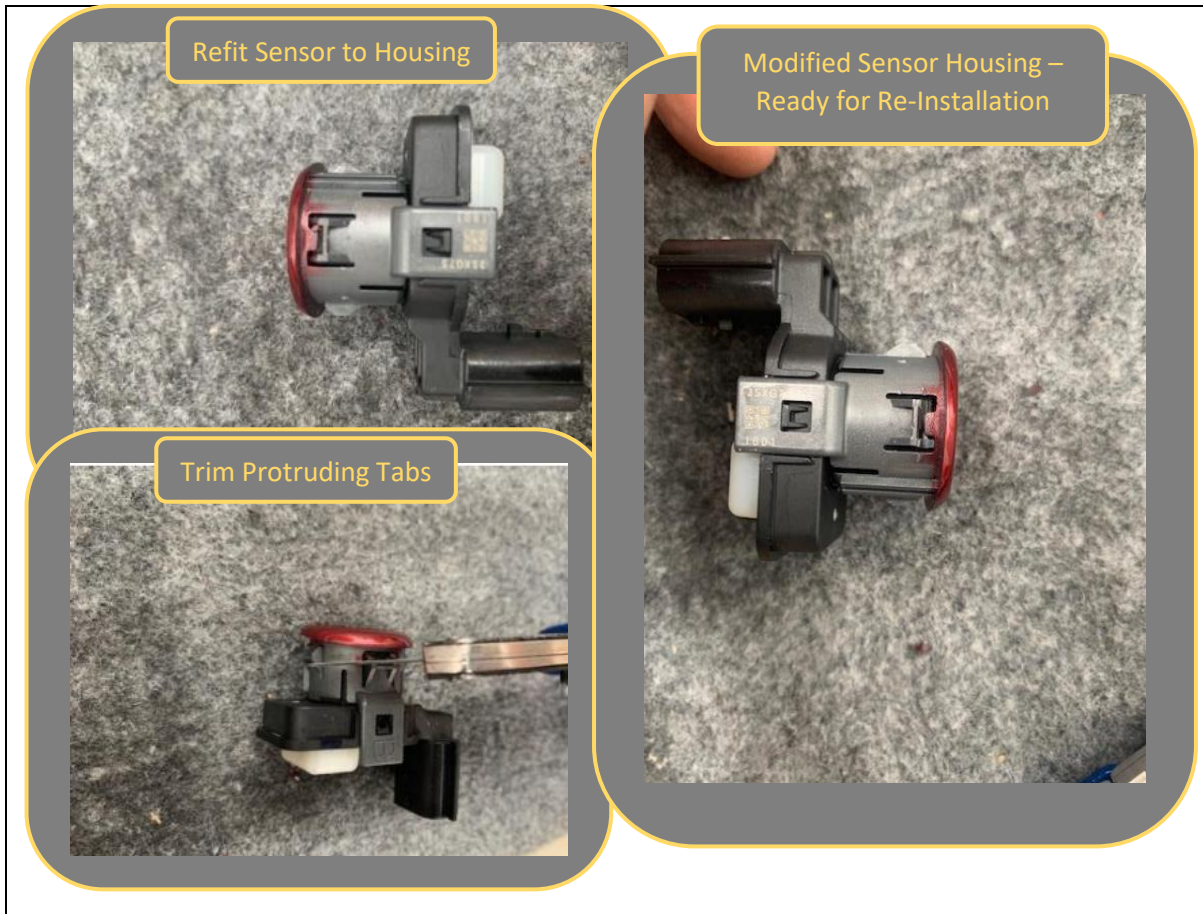

<p>41. Re install wiring harness to bar and plug in connectors for fog light and indicators</p> <p>42. If equipped with parking sensors, you'll need to do a small mod to allow them to grip on the bull bar which is thicker than the factory bumper.</p>	<p>TOOLS REQUIRED Utility Knife</p>
<p>43. Fit sensor back into housing (top left)</p> <p>44. Using a Utility knife trim 2mm off the front of the push in tabs (up to the join in the middle as shown in bottom left) Do for all 4 tabs around sensor.</p> <p>45. Photo to the right shown, is a completed sensor. Repeat for other sensors.</p> <p>46. Re-fit parking sensors to bar by relocating original housings to the holes on the bar.</p> <p>47. If parking sensors not equipped fit plastic blanking plugs to parking sensor holes on bar.</p>	<p>FASTENERS</p>



- 48. If fitting an integrated light bar, do so now. Leave bolts loose at this stage to allow fitment of mesh panels.
- 49. The bar is designed to fit a Offroad Animal 22 inch light bar. If fitting this light bar, assemble bar with legs out, and it will line up with the slots in the center gusset. Secure with fasteners supplied with the light bar.
The bar can accommodate most other “20 inch” size light (20-22 inch long) bars
- 50. If fitting stealth top hoop or round lights do so at this stage.
- 51. Fit the Lower Grille mesh panel to the top pan of the bar.
- 52. Fit the Pan Brace between the center gusset and top of pan at the center using supplied fasteners. The top fastening uses the same bolt as the center of the lower grille mesh panel.

TOOLS REQUIRED
Refer to light bar instructions

FASTENERS
Supplied with Light bar
M6x16 Button
M6 Flat washer
M6 Flange Nut



53. Fit 5x cage nuts from small parts kit to rectangular slots in bottom of wing.

Use a small flat bladed screwdriver to push the edge of the cage to engage with the slot to aid fitting.

TOOLS REQUIRED
Flat Blade Screwdriver

FASTENERS

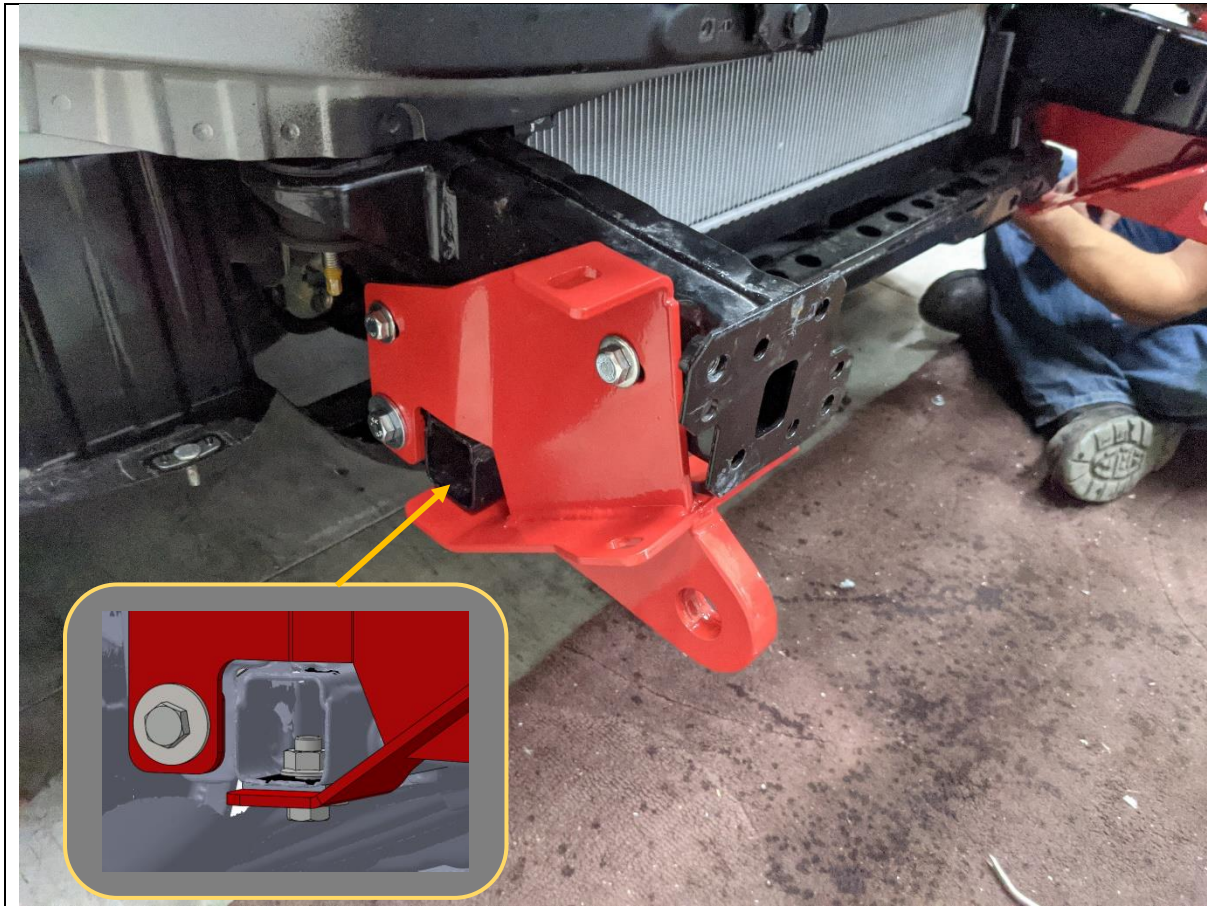

54. Fit the Tow Point to the chassis using the lollipop nut plate through the center of the chassis rail and the M10 / M12 nut plate behind the rear section of chassis. Use M12X30 bolt with flange nut inside chassis rail for bottom of mount.

55. Secure in place to threaded mounting points in chassis using original factory bolts. Leave bolts loose at this stage.

TOOLS REQUIRED

FASTENERS

- 2x M10x30
- 1x M10 Lollipop Nut Plate
- 2x M12x30 Bolt
- 1x M12 Flange Nut
- 2x M10 Flat Washer
- 2x M12 Flat Washer
- 1x M10 + M12 Nut Plate

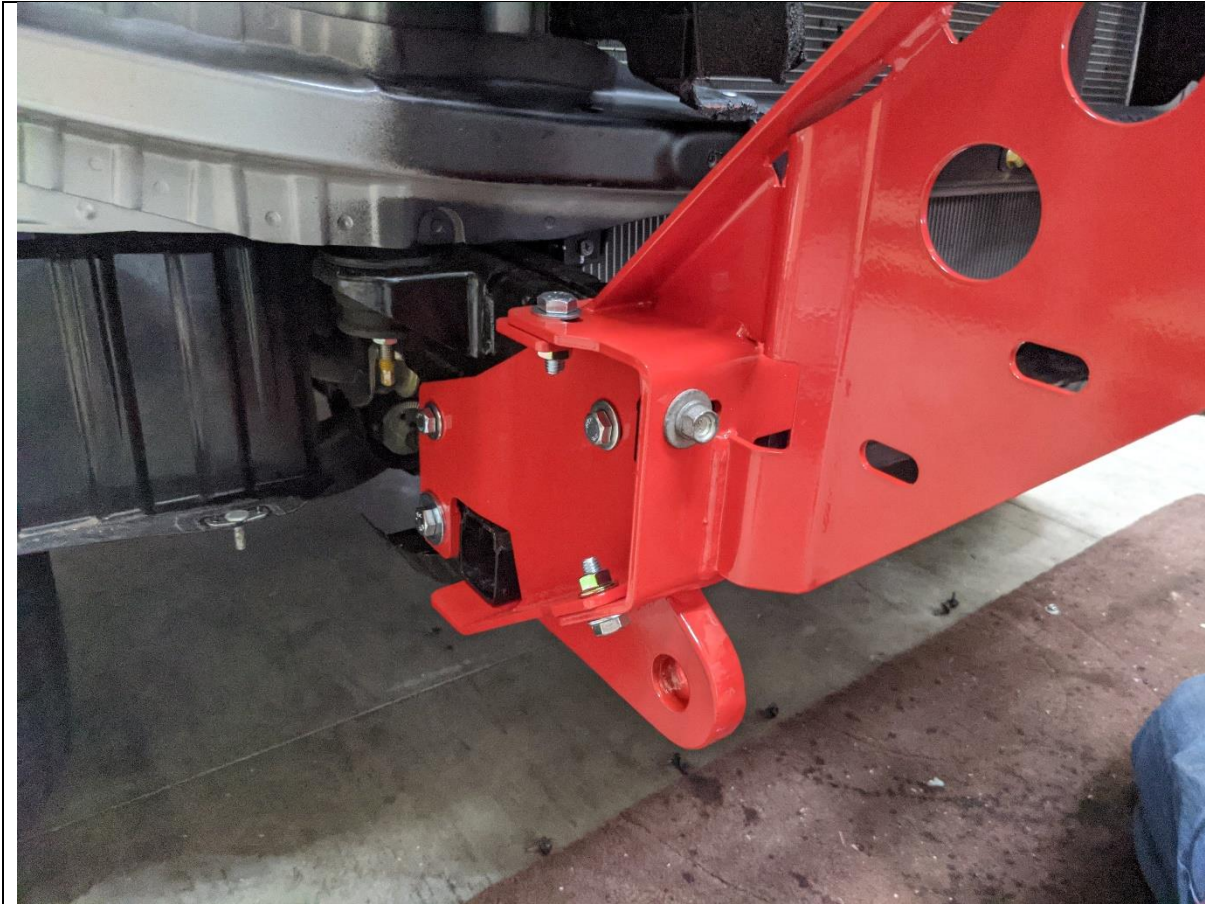

- 56. Fit the impact assembly to the chassis using the 14mm head factory bolts retained from the crash beam.
- 57. Secure to the tow point using 3x M10x30 bolts, flat washers and flange nuts as shown.
- 58. Repeat for both sides of vehicle. Leave finger tight at this stage

TOOLS REQUIRED

FASTENERS

- 2x Factory M10x1.25P Bolts
- 3x M10x30 Hex Bolt
- 3x M10 Flat washer
- 3x M10 Flange Nut

Per Side

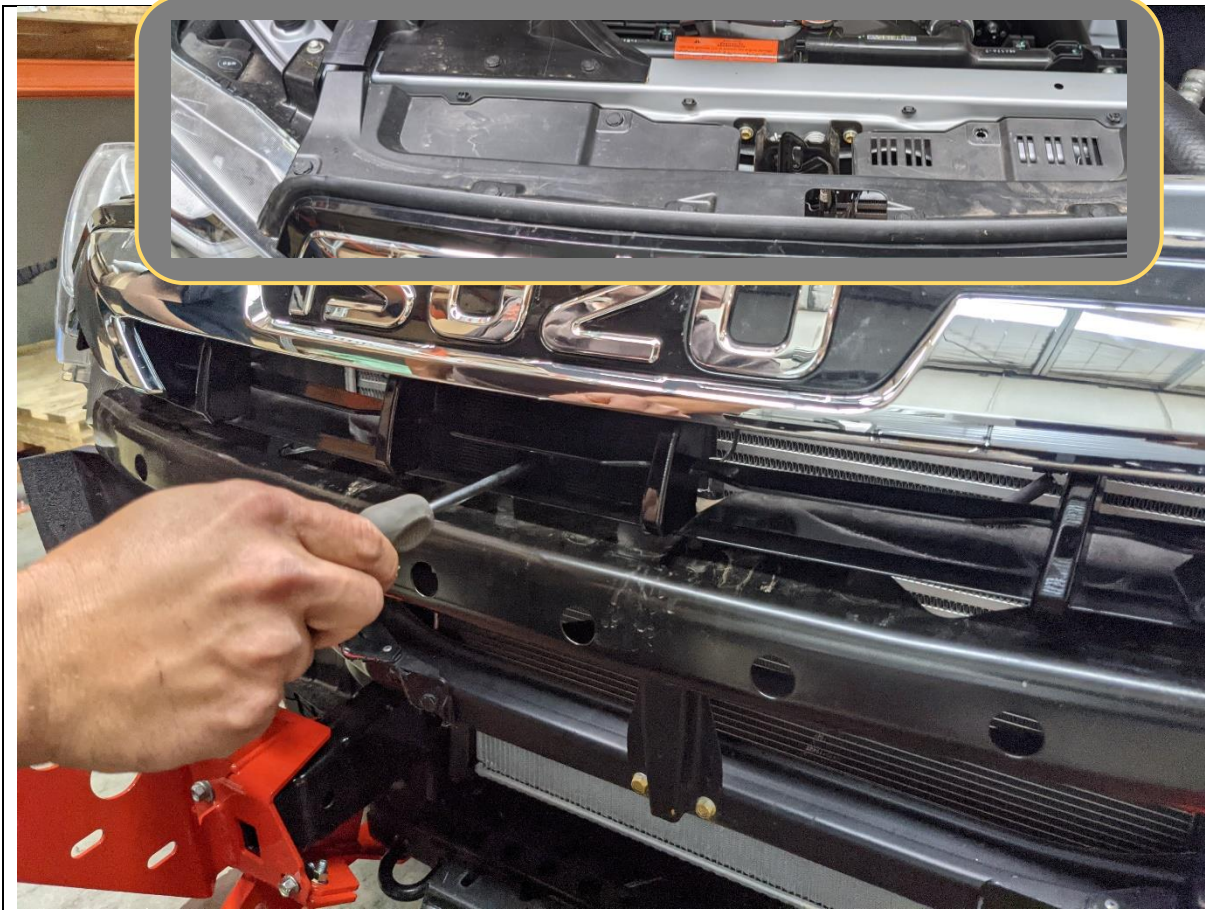

59. Re fit the upper grille section to the vehicle, re using the factory clips and screw.

TOOLS REQUIRED
Phillips Screwdriver

FASTENERS
Re Use Factory

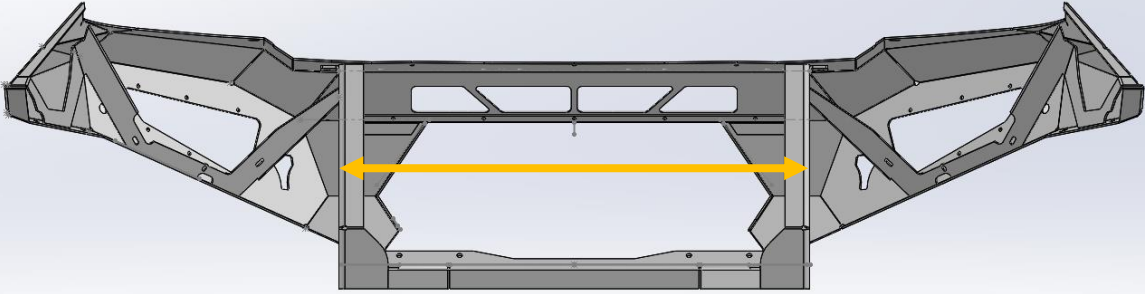
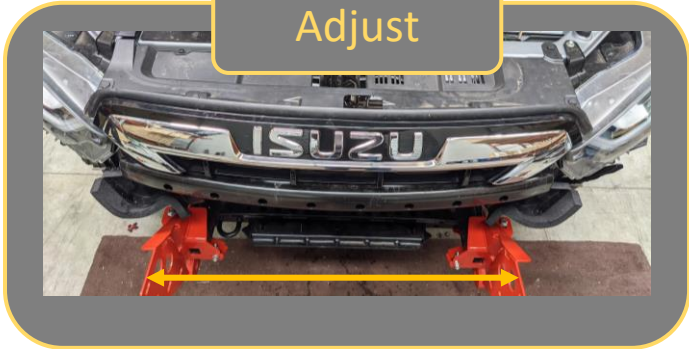
<div data-bbox="671 237 963 331" style="border: 1px solid black; border-radius: 10px; padding: 5px; display: inline-block; background-color: #f0f0f0;"> <p>MEASURE</p> </div> 	
<div data-bbox="660 696 952 790" style="border: 1px solid black; border-radius: 10px; padding: 5px; display: inline-block; background-color: #f0f0f0;"> <p>Adjust</p> </div> 	
<p>60. Measure distance between bullbar uprights with tape measure. Note down this distance</p> <p>Distance = _____</p> <p>61. Measure and adjust the distance between the mounts on the vehicle to be 2-5mm greater than the distance measured.</p> <p>62. Tighten all bolts securing impact assembly and tow point, and re check distance. Re adjust as required to achieve correct distance.</p>	<p>TOOLS REQUIRED</p> <p>13mm Socket 14mm Socket 16mm Socket</p> <hr/> <p>FASTENERS</p>

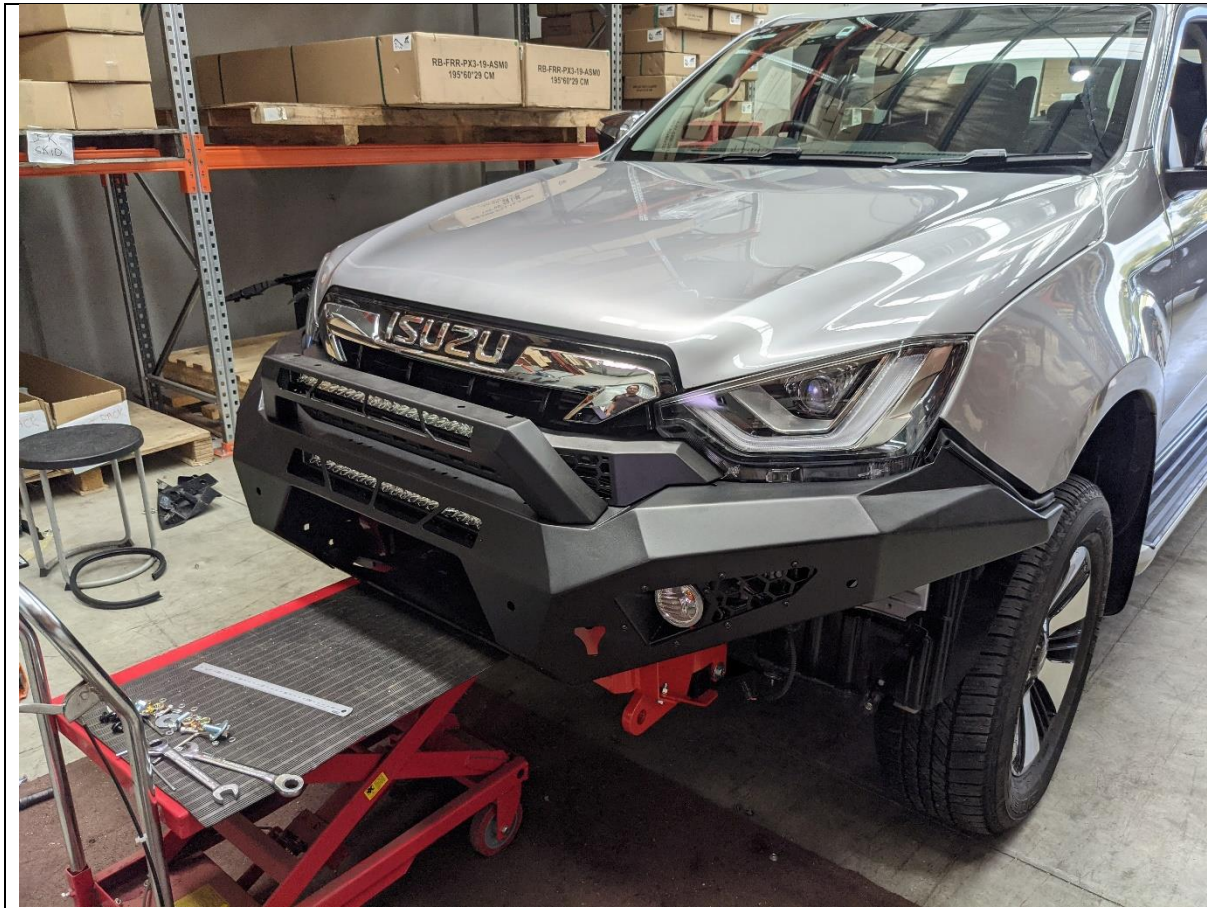

63. With assistance, either from another person or a lifting trolley, lift the bar onto the mounts on the vehicle.

TOOLS REQUIRED

Lift Trolley

FASTENERS



64. Secure bar to mount with 4x M12x30 Bolts, heavy duty washers and 3x M12 Nyloc and 1x M12 flange nut per side. Finger tight at this stage.
65. With assistance, from another person, align the bar with the edges of the vehicle. Adjust such that the clearances are neat and even side to side. When happy, tighten the bolts with the flange nut to lock the bar in position.
- Acceptable range of clearances shown in image above.
Ensure clearances are maintained all the way through below the headlight.
66. Once in position, tighten the M12 bolts using socket and spanner. An impact driver may be used to speed up this process.

TOOLS REQUIRED
Lifting Trolley
19&18mm Socket and Spanner

FASTENERS
8x M12x40 Bolt
16x M12 Heavy Duty Large Washer
8x M12 Nyloc Nut



- 67. If fitting a winch, do so now.
- 68. The bar is designed to fit most low mount winches, in foot down configuration. WARN ZEON 10 is largest winch confirmed to fit.
- 69. The control box can to be mounted on top of the winch. Winches usually come with a bracket to allow this. Refer to winch manufacturer.

TOOLS REQUIRED

Refer to winch Instructions

FASTENERS

Refer to Winch instruction.

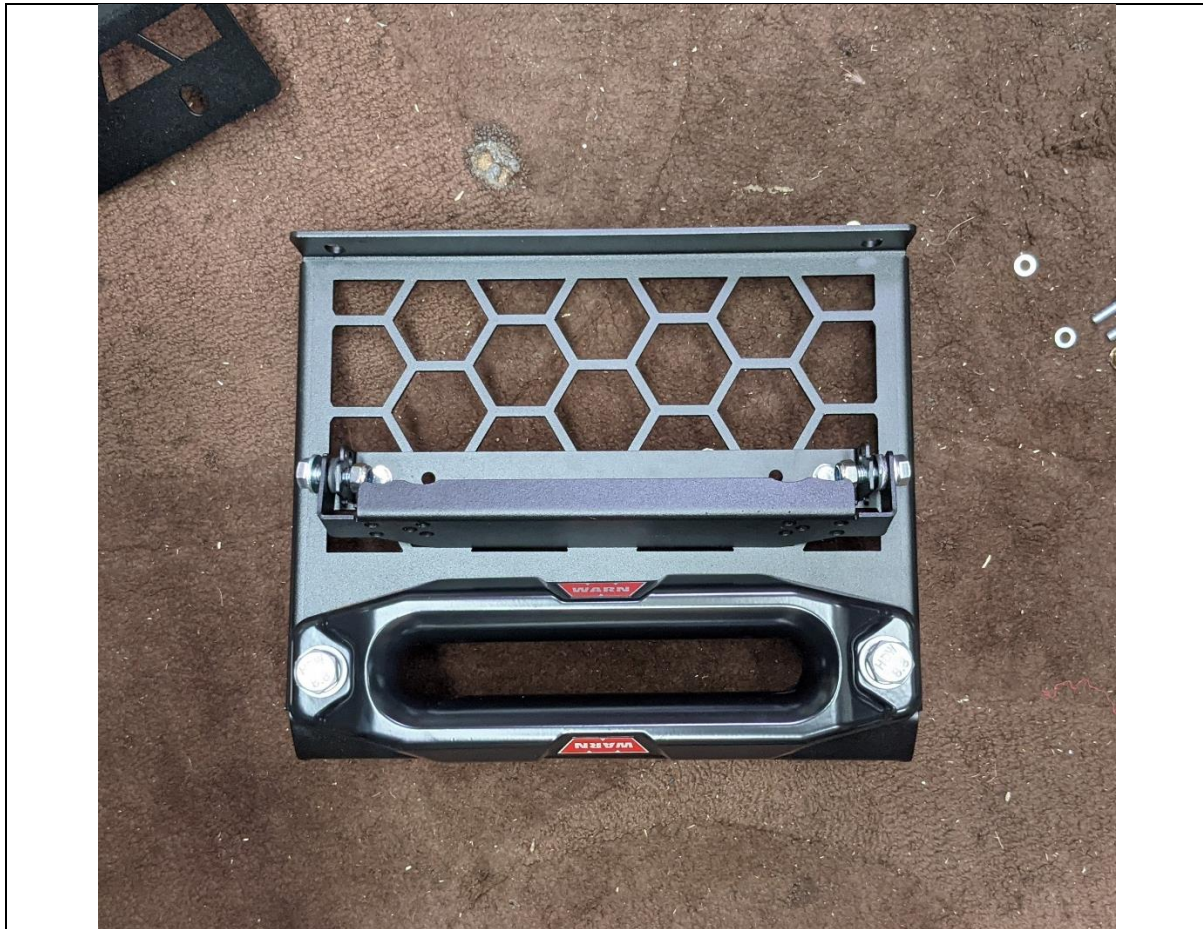

- 70. Prepare the center mesh panel for fitment.
- 71. If required, fit winch fairlead to Mesh Fairlead Mount (M-0014). Use M10 or 3/8" fasteners supplied with winch. The bar is only compatible with Hawse type fairleads.
- 72. Fit number plate flip kit to fairlead mount, using fasteners supplied in kit.

TOOLS REQUIRED

Depends on winch supplied fasteners

FASTENERS



- 73. Fit the Mesh Fairlead Mount (M-0014) to the center of the bar, using M8x16 Button head (Top), M8x20 Button Head (Bottom) M8 Flat Washers and M8 Flange Nuts.
- 74. Tighten fasteners using 13mm socket / spanner and 5mm Allen Wrench.

TOOLS REQUIRED

- 13mm Spanner
- 5mm Allen Wrench

FASTENERS

- 2x M8x16 Button Head
- 2x M8x20 Button Head
- 4x M8 Flange Nut
- 4x M8 Flat Washer



75. Fit Mesh Infill Panels (M-0008L/R). Secure with M8x16 button head bolt and M8 flat washer into the threaded insert in bar for top mount. The flange of the infill panel should sit on the inside of the bar.

76. Don't fit any bolts to bottom holes at this stage.

77. Tighten top fasteners using 5mm Allen Wrench.

TOOLS REQUIRED
5mm Allen Wrench

FASTENERS

2x M8x16 Button Head
2x M8 Flange Nut

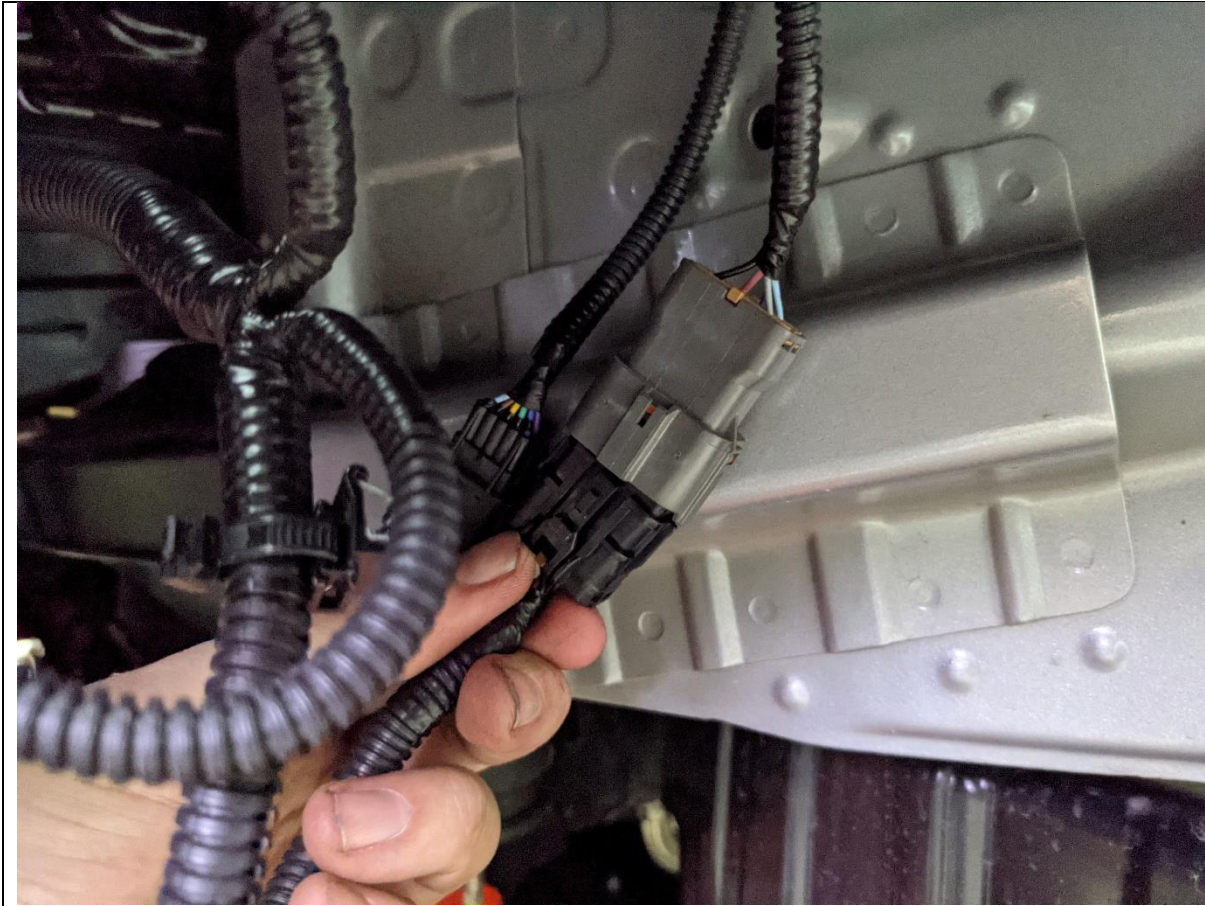

78. Re-connect fog light and parking sensor (if equipped) wiring connectors.

TOOLS REQUIRED

FASTENERS

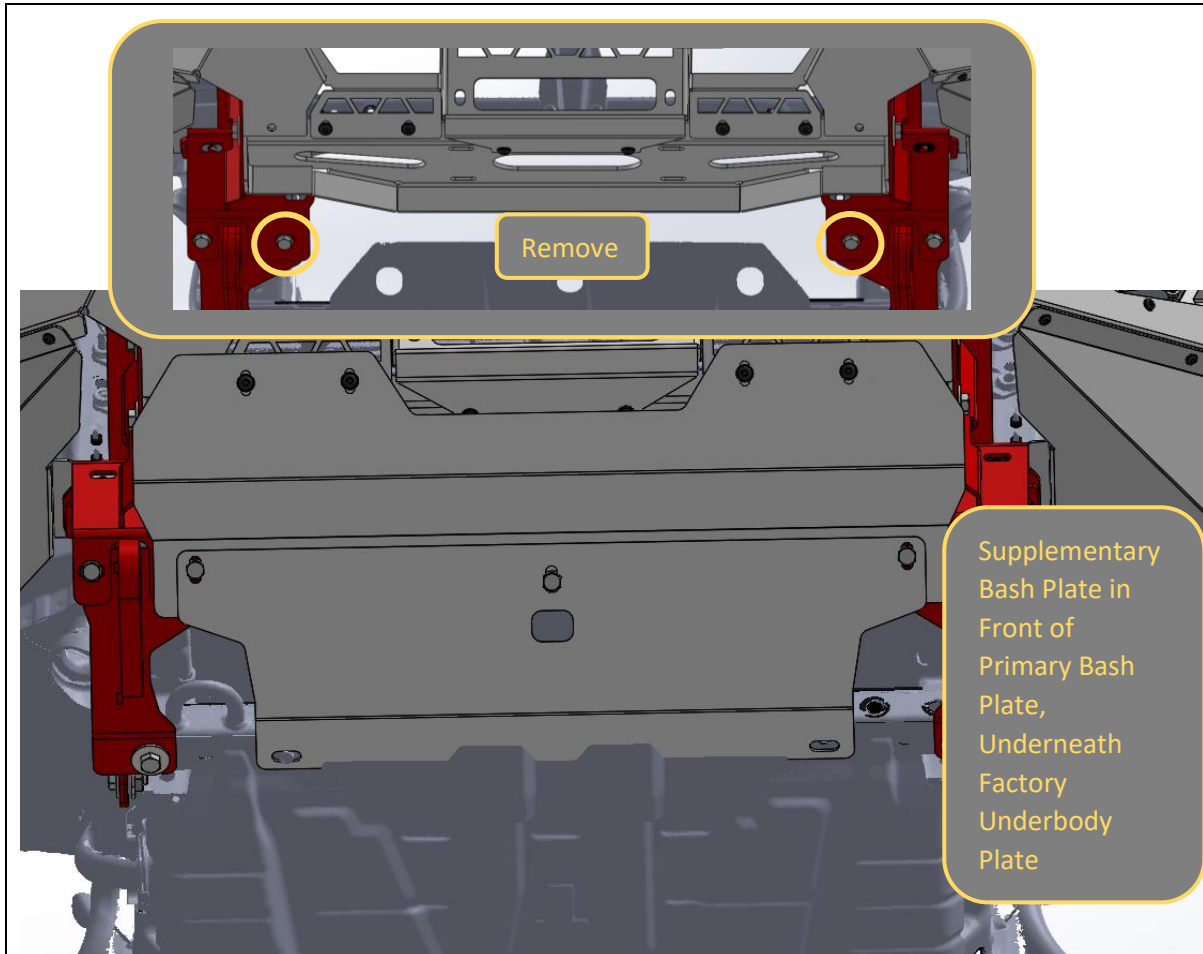

- 79. Before fitting bash plates, remove the M10x30 Bolts on the inside of the tow point / impact assembly joint.
- 80. Fit Center Bash Plate using M8x20 button head, flat washer and flange nut to front face. Ensure these fasteners pass through the side mesh panels.
- 81. Secure the Supplementary and back of Center Bash Plate using M10x30 hex head, flat washers and M10 flange nut removed in previous step, through the tow point / impact assembly parts.
- 82. Secure bottom of Supplementary bash plate to the factory bolt points, using factory fasteners. Refit the factory underbody on top of the supplementary bash plate.
- 83. Tighten All Bottom fasteners using 16/17mm spanner & socket
- 84. Tighten front fasteners using 13mm socket / spanner and 5mm Allen Wrench. Reach through access hole in mesh panel to reach nut.

TOOLS REQUIRED

- 16/17mm Spanner
- 16/17mm Socket
- 5mm Allen Key
- 13mm spanner

FASTENERS

- 4x M8x20 Button Head
- 4x M8 Flange Nut
- 4x M8 Flat Washer

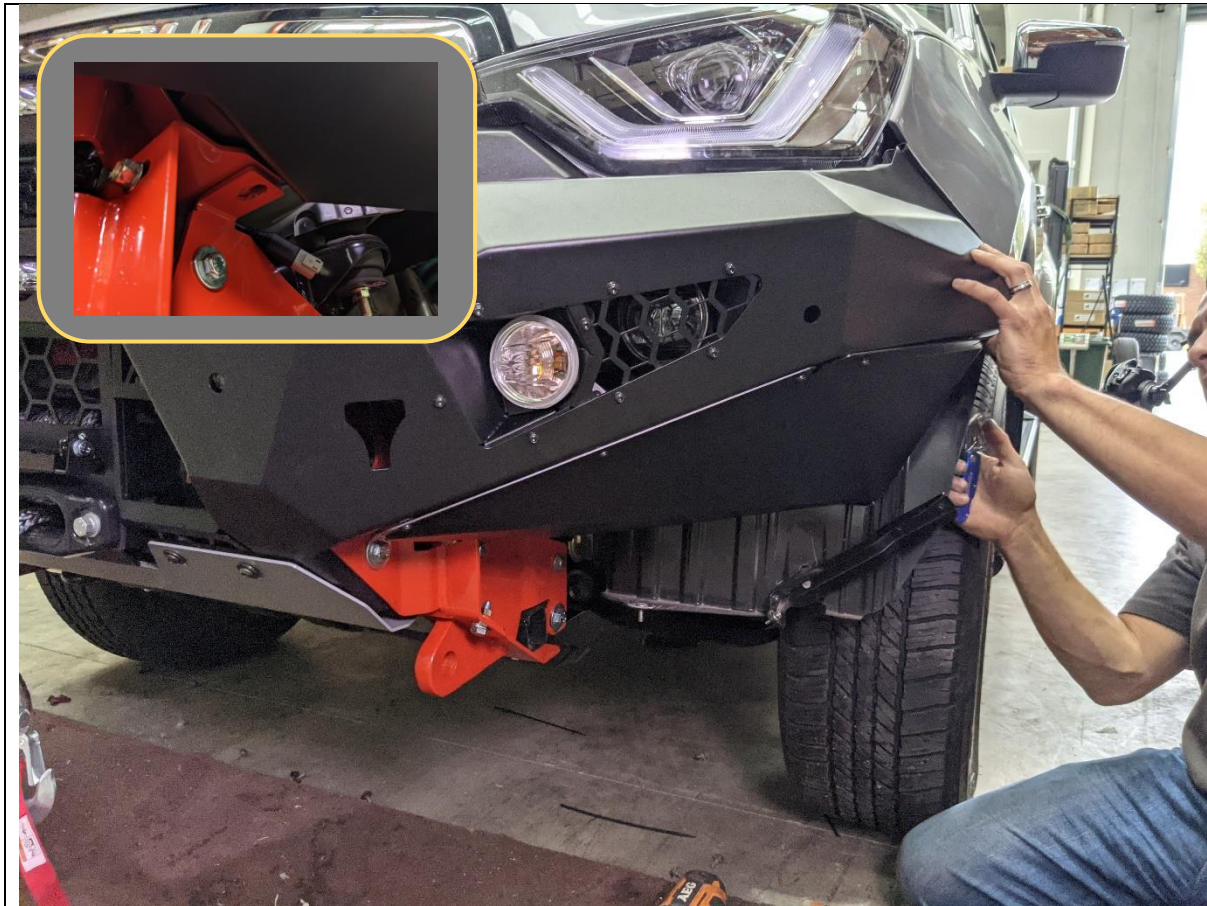

85. Remove the outside top bolts from impact assembly/tow point.

86. Fit the side under panels by first sitting the bottom mount on top of the impact assembly, then inserting the 5x M6x16 bolts into the cage nuts fitted earlier

87. Tighten with 4mm Allen wrench

88. Secure bottom of side under panel to mount using bolt removed from joint earlier.

89. Tighten with 16/17mm spanner / socket

TOOLS REQUIRED

- 16/17mm Spanner
- 5mm Allen Wrench
- 4mm Allen Wrench

FASTENERS

- 10x M6x16 Button Head
- 10x M6 Flat Washer

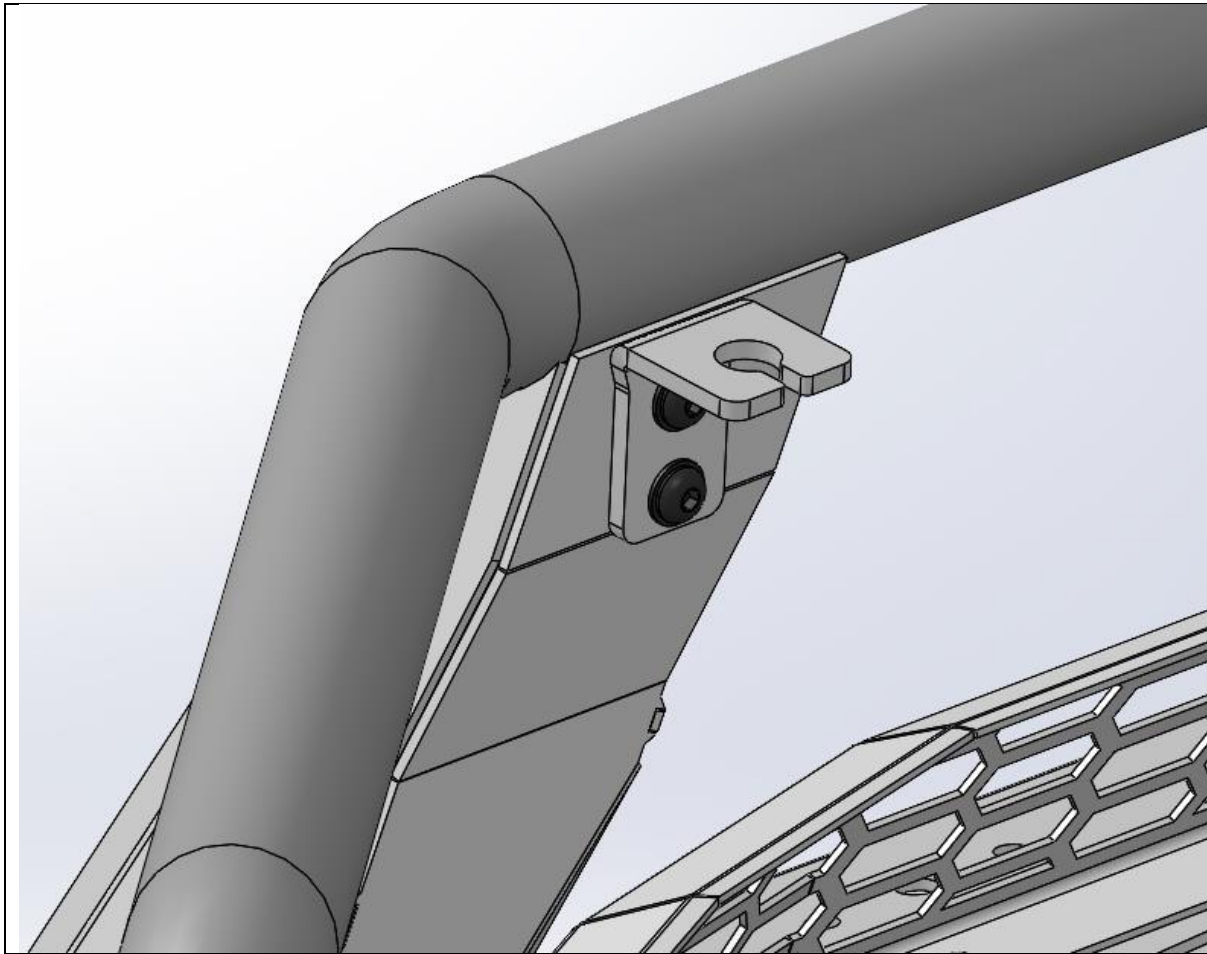

90. If fitting antennas to a Toro bar, Fit the antenna brackets to the back side of the uprights using supplied M8x20 Button head bolts, Washers into the weld nuts in the bar uprights

TOOLS REQUIRED
5mm Hex Key

FASTENERS
2x M8x20 Black Button Head
2xM8 Flat Washer
Per Side



91. Using a sharp utility knife, cut back the plastic inner wheel arch liner to match the profile of the under panel.
92. Tuck the wheel arch liner behind the flanges on the under panel.
93. Repeat for both sides of vehicle.

TOOLS REQUIRED
Utility Knife

FASTENERS



- 94. Re-check that all fasteners are tight.
- 95. Re-tit number plate to number plate flip.
- 96. You're done. Hit the tracks and enjoy your newly protected DMAX!

TOOLS REQUIRED

FASTENERS