



LAND ROVER DEFENDER 110/130 L663 MY20+ Scout Roof Rack FITTING INSTRUCTION

IMPORTANT! – READ BEFORE INSTALLATION

- This product must be installed exactly as per these instructions using only hardware supplied.
- Take a few moments to read instructions thoroughly before beginning work.
- In the event of damage to any bar component please contact OFFROAD ANIMAL to arrange repair/replacement of components.
- Do not use this product for any vehicle make or model other than that specified on these instructions.
- Do not remove labels from this product.
- This product and its fixings must not be modified in any way unless stated in these fitting instructions.
- The installation of this product is recommended for trained personnel.
- These instructions are correct at time of publication. OFFROAD ANIMAL cannot be held responsible for the impact of any changes subsequently made by the vehicle manufacturer. If you find something has changed, please contact us to let us know!
- During installation it is the duty of the installer to check correct operation/clearances of all components.
- If Instructions are to be printed for reference in the workshop, it is recommended that they are printed in colour, for best legibility.

- Roof Rack Load Rating = **136KG (that is 136KG of Cargo Permissible)**
- Vehicle Roof Rating = **168KG (Given by Vehicle Manufacturer)**
- Rack Weight = 32KG

PARTS LISTING

IMPORTANT: Check all parts are present before beginning work! Contact OFFROAD ANIMAL if something is missing.

Main Parts – In the Box

Qty	Part Number	Description	Image
7	E-0005-1150	Scout Roof Rack - Cross Bar Extrusion 1150MM	
1	B-1198L	Defender 110 L663 Scout Rack Side Rail	
1	B-1198R	Defender 110 L663 Scout Rack Side Rail	
1	B-1199	Defender L663 Scout Rack Front Panel	
1	B-1200	Defender L663 Scout Rack Wind Deflector	
1	B-1202L	Defender L663 Scout Rack Front Mount Bracket	
1	B-1202R	Defender L663 Scout Rack Front Mount Bracket	
1	B-1208L	Defender L663 Scout Rack Mid Mount Bracket	
1	B-1208R	Defender L663 Scout Rack Mid Mount Bracket	
1	B-1204L	Defender L663 Scout Rack Rear Mount Bracket	



1	B-1204R	Defender L663 Scout Rack Rear Mount Bracket	
6	P-0397	Defender L663 Scout Rack Track Bolt Plate	
6	P-0398	Defender L663 Scout Rack Track Spacer Plate	

Small Parts – Contained in Small Parts Kit Bag

QTY.	PART NO.	DESCRIPTION
66	M8 HD FLAT WASHER - BZP	M8 FLAT WASHER - High Tensile 19x8x2mm, ISO4042 ZnNi BLACK PASSIVATED FINISH
42	M8 X 20 BHCS BLACK ZINC	SCREW, BUTTON HEAD CAP, M8X20X1.25, ISO4042 ZnNi BLACK PASSIVATED FINISH
26	M8 FLANGE NUT	Flange Nut, M8x1.25 G8.8 ZP
24	M8 NUT	Hex Nut, M8x1.25 G8.8 ZP
14	M8 X 16 BHCS BZP	SCREW, BUTTON HEAD CAP, M8X16X1.25 GR12.9, ISO4042 ZnNi BLACK PASSIVATED FINISH
10	M8 X 12 BHCS BZP	SCREW, BUTTON HEAD CAP, M8X12X1.25 GR12.9, ISO4042 ZnNi BLACK PASSIVATED FINISH
6	M6x12 BHCS BLACK ZINC	SCREW, BUTTON HEAD CAP, M6X12X1 GR12.9, ISO4042 ZnNi BLACK PASSIVATED FINISH
16	M6 FLAT WASHER BLACK ZINC	M6 Flat Washer, 12x6.1x1, ISO4042 ZnNi BLACK PASSIVATED FINISH
10	M6x16 BHCS BLACK ZINC	SCREW, BUTTON HEAD CAP, M6X16X1 GR12.9, ISO4042 ZnNi BLACK PASSIVATED FINISH
6	M6 FLANGE NUT	Flange Nut, M6x1 G8.8 ZP



TOOLS REQUIRED

The following tools will be required to install the product. Note Extra Tools will be required for fitment of track kit. Refer to track kit

Hand Tools	Power Tools	Workshop Supplies
Metric Socket Set 8-19mm Socket Extension Bar Metric Spanner Set 10-19mm Hex (Allen) Key Set 4-6mm Torque Wrench Metric Crows foot socket		Soft Blanket Forklift + Slings Or 3x Extra Helpers

WORKSHOP SAFETY

It is the responsibility of the installer to always complete works in a safe manner. Make sure the following safety equipment is available and precautions are observed whilst fitting this product.

<p>Hearing Protection</p> 	<p>Always wear ear protection when using power tools.</p>
<p>Eye Protection</p> 	<p>Ensure eye protection is always worn when cutting or drilling.</p>
<p>Manual Handling</p> 	<p>Do not attempt to lift bar assemblies or rock sliders on your own.</p> <p>Always use two people to lift or use mechanical Lifting aid such as hydraulic lifting trolley.</p>
<p>Vehicle Support</p> 	<p>Always ensure vehicle is properly supported when working on it. Do not attempt to fit products whilst suspension work is being carried out. Do not work under a vehicle supported only by a jack.</p>



1. Factory Land Rover Roof Rails are required for the fitment of the rack, (Land Rover part number VPLER0177)
2. The rack is compatible with Genuine Accessory Roof Ladder and Side Gear Carriers. If fitting side gear carrier this must be fitted before the rack. The ladder may be fitted before or after the rack is fitted but will be easier to install beforehand.
3. If not fitted as standard on the vehicle, fit the roof rails first following the Land Rover instructions.
4. If equipped, lower air suspension to Access height to make it easier to reach the roof.

TOOLS REQUIRED

FASTENERS



5. Assemble the roof rack. Start by setting out the 7 extrusions on a table or panel stand. Position them so they sit approximately 300mm apart.
6. **IMPORTANT ASSEMBLY NOTE:** For **ALL FASTENERS** during the assembly process leave finger tight until tightening step.

TOOLS REQUIRED

Table or Panel Stands

FASTENERS



7. Fit the side rail to the extrusion,

This is easiest to do when the ends of the extrusions are hanging over the edge of a table / workbench.

8. Secure using M8x20 Button Head bolts and flat washer through the side face into the Tapped holes on the side face of the extrusion.
9. Complete steps for both side rails.

TOOLS REQUIRED
5MM Hex Key

FASTENERS

14x M8x20 Button head bolt.
14x M8 Flat Washer
per side

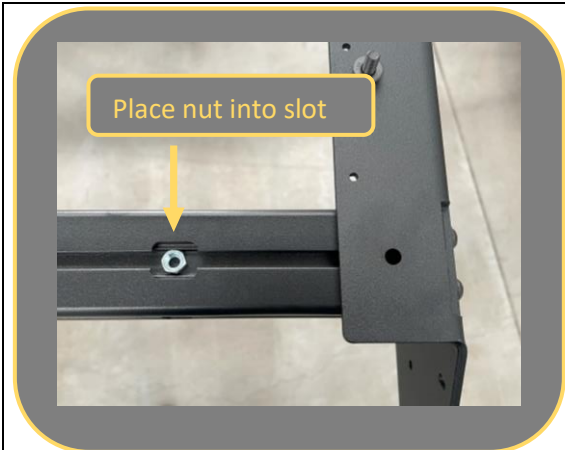
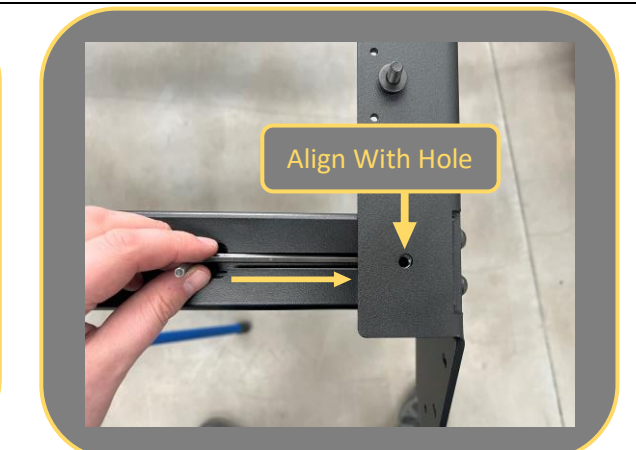
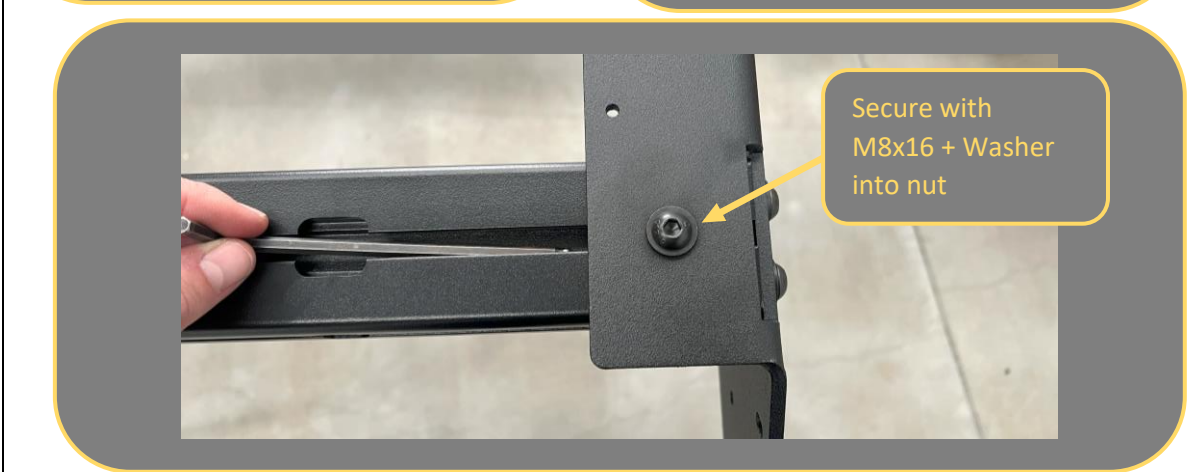
	
	
<p>10. Insert M8 Nut into each track for securing top face of side rail.</p> <p>11. Drop nut into slot in extrusion, then slide nut sideways in slot and align with hole in the side rail.</p> <p>12. Secure with M8x16 Bolt + Flat Washer.</p>	<p>TOOLS REQUIRED 5MM Allen Key</p>
<p>13. Complete top bolt fitment for other side of rail.</p>	<p>FASTENERS 7x M8 Nuts 7x M8x16 Button head bolt 7x M8 Black Washer</p> <p>Per Side</p>



14. Insert 5x M8 nuts into the front slot of the front extrusion.
15. Using the hole positions in the vertical face of the front panel as a guide, use a screwdriver to move nuts into correct positions. Gravity should hold the nut in position.
16. Position 5x M8x12 Button head and M8 Flat washers on the rack within easy reach for the next step.

TOOLS REQUIRED
Screwdriver

FASTENERS
5x M8 Nuts



17. Fit the Front panel to the rack assembly. Secure to the pre-placed nuts in the front extrusion using the M8x12 Button head bolts and flat washers.
18. Next, Secure the Front panel to the side arm using 3x M6x16 Button head bolts, flat washers, and Flange nuts per side
19. **Tighten** the 5x M8 Button head screws securing front panel to the extrusion. Leave other bolts finger tight.

TOOLS REQUIRED
5MM Hex Key

FASTENERS
5x M8X12 Button Head Bolt
5x M8 Flat Washer
6x M6X16 Button Head Bolt
6x M6 Flat Washer
6x M6 Flange Nut Washer

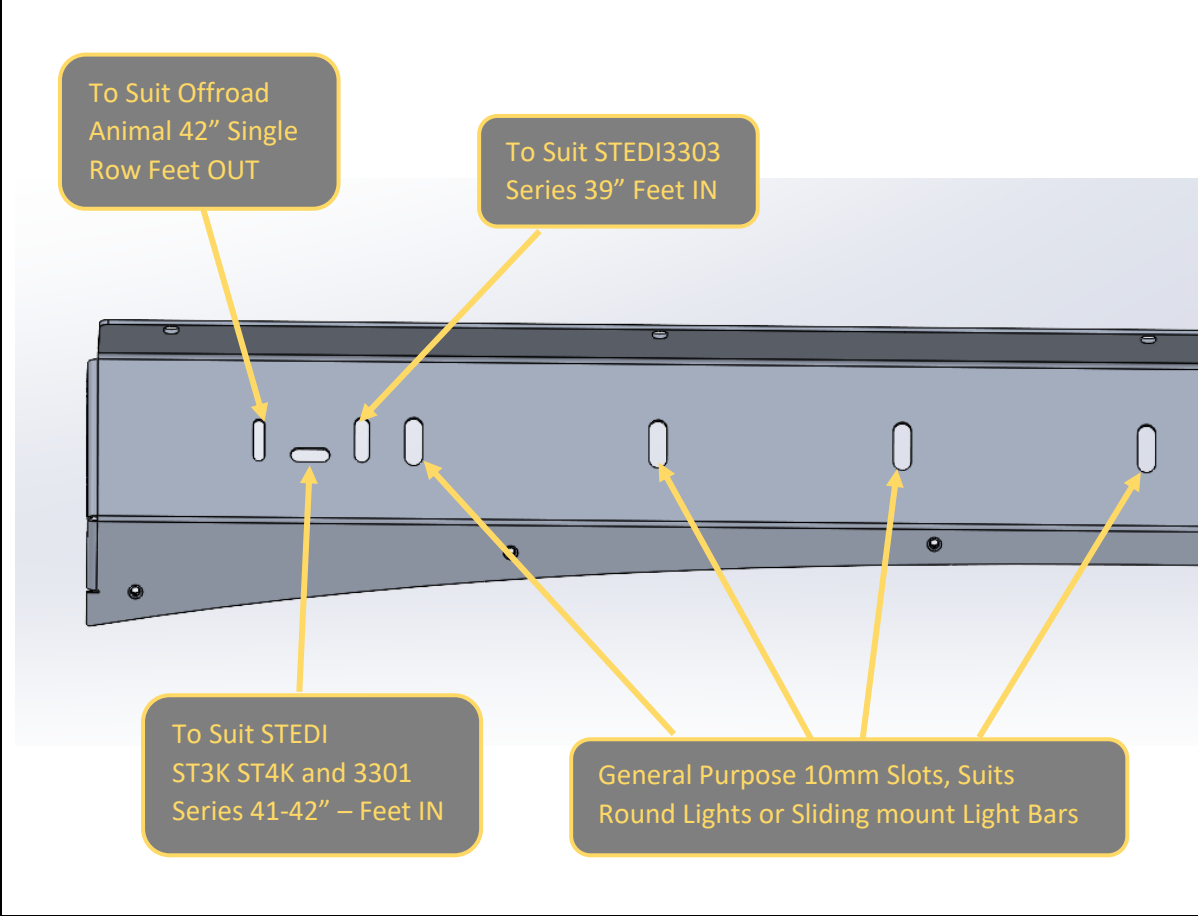
	
<p>20. If fitting a light bar or other lights to the front of rack – do so now. Refer to above image to identify appropriate slots to use.</p> <p>21. If lights are fitted skip to step 24.</p>	<p>TOOLS REQUIRED</p>
<p>FASTENERS</p> <p>Fasteners Supplied with Lights</p>	



22. If not fitting lights, prepare for fitment of wind deflector by positioning 5x M8 nuts into the top slot of the front extrusion.
23. Using the hole positions in the top face of the wind deflector as a guide, use a screwdriver to move nuts into correct positions. Gravity should hold the nut in position.
24. Position 5x M8x12 Button head and M8 Flat washers on the rack within easy reach for the next step.

TOOLS REQUIRED

FASTENERS

5x M8 Nuts

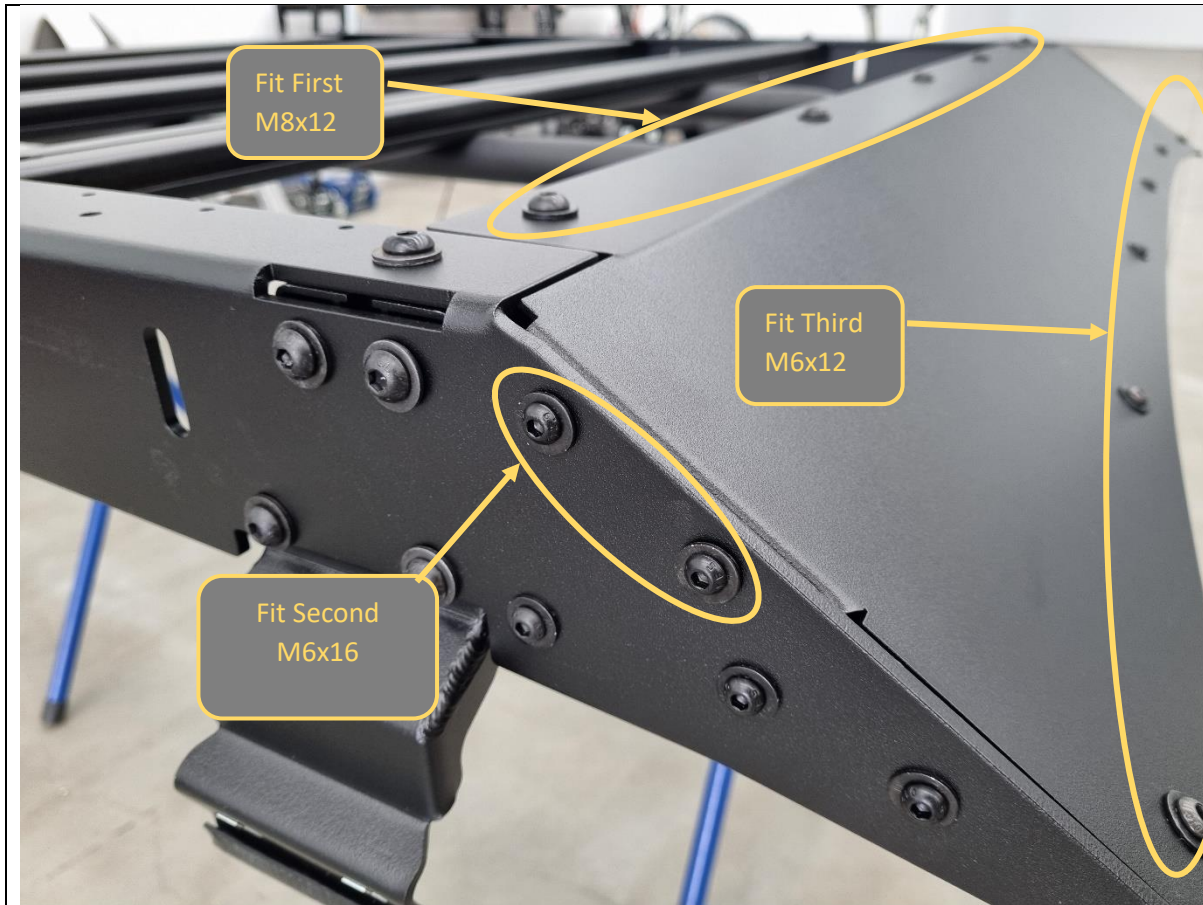

25. Fit the wind deflector to the rack. Secure to the pre-placed nuts in the front extrusion using the M8x12 Button head bolts and flat washers.
26. Next, Secure the Wind deflector to the side arm using 2x M6x16 Button head bolts, flat washers, into captive nuts on the wind deflector.
27. Finally, Secure the Wind deflector to the Front Panel using 6x M6x12 Button head bolts, flat washers, into captive nuts on the Front Panel.

TOOLS REQUIRED

FASTENERS

- 5x M8X12 Button Head Bolt
- 5x M8 Flat Washer
- 4x M6X16 Button Head Bolt
- 6x M6X12 Button Head Bolt
- 10x M6 Flat Washer



28. Identify Front mount, this is the mount with the protruding fold on the base of the mount.
29. Fit the front mounts to the rack using M8x20 Button head bolts, Flat washers and Flange Nuts. Ensure the arrow on the mounts faces towards the front of the rack.
30. Leave nuts finger tight such that the mount can slide on the slots.
31. Complete these steps for both sides of the vehicle.

TOOLS REQUIRED

FASTENERS

- 2x M8x20 Button Head
- 2x M8 Flat Washer
- 2xM8 Flange Nut
- Per side



32. Identify the center mount, this is the mount with the 90-degree fold on the base of the mount.
33. Fit the center mounts to the rack using M8x20 Button head bolts, Flat washers and Flange Nuts. Ensure the arrow on the mounts faces towards the front of the rack.
34. Leave nuts finger tight such that the mount can slide on the slots.
35. Complete these steps for both sides of the vehicle.

TOOLS REQUIRED

FASTENERS

- 2x M8x20 Button Head
- 2x M8 Flat Washer
- 2xM8 Flange Nut
- Per side

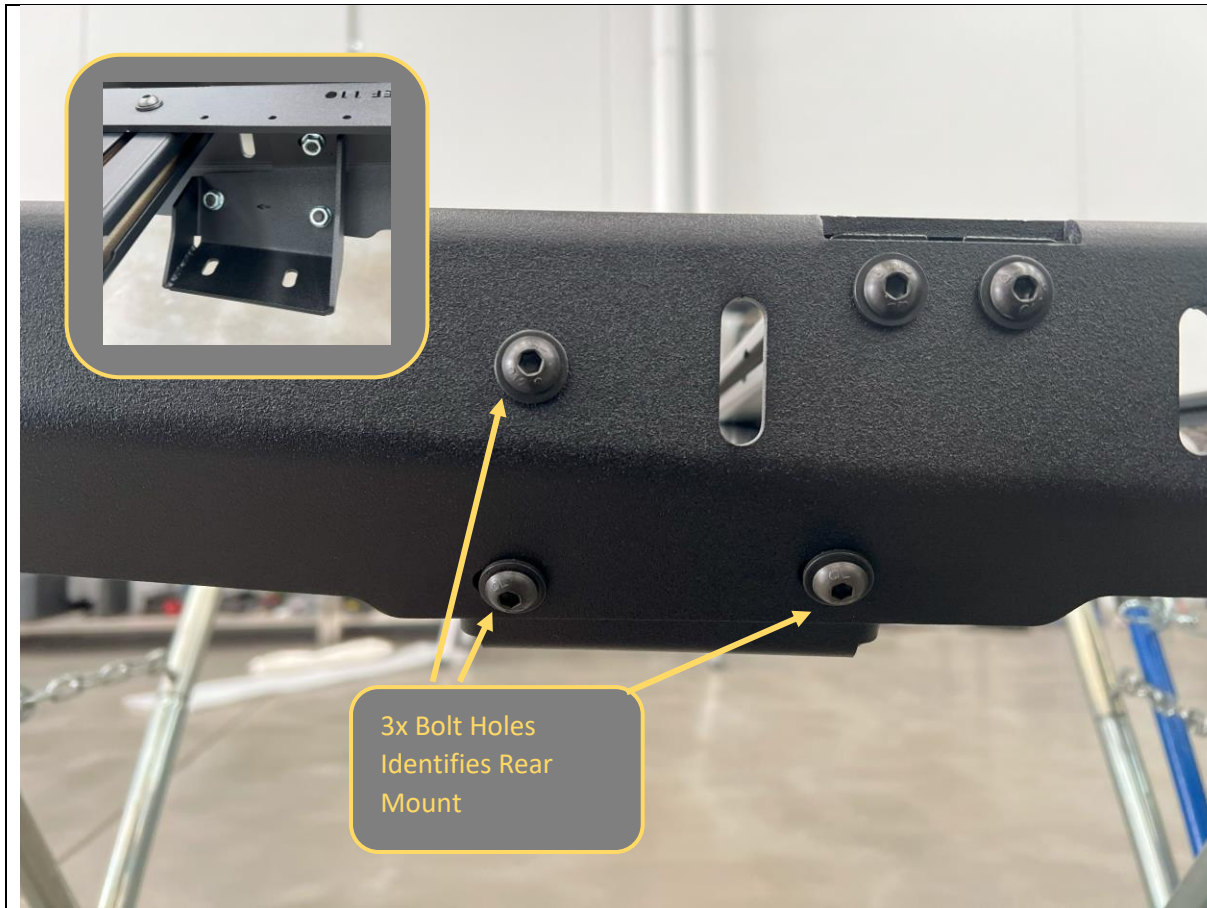

36. Identify the rear mount, this mount is angled and has 3x bolt holes.
37. Fit the rear mounts to the rack using M8x20 Button head bolts, Flat washers and Flange Nuts. Ensure the arrow on the mounts faces towards the front of the rack.
38. Leave nuts finger tight such that the mount can slide on the slots.
39. Complete these steps for both sides of the vehicle.

TOOLS REQUIRED

FASTENERS

- 3x M8x20 Button Head
- 3x M8 Flat Washer
- 3xM8 Flange Nut
- Per side



40. Now is time to **TIGHTEN ALL** bolts securing the components of the rack assembly together.
41. First **Tighten** all horizontal bolts securing the side rails to the Extrusions and front panel / wind deflectors. Complete on both sides
42. Next **Tighten** all vertical bolts.
43. Work methodically from front to back to ensure no bolts are missed.
44. Leave the foot to side rail bolts finger tight, such that the mounts are free to slide on the slots.

TOOLS REQUIRED

4mm Hex Key
5mm Hex Key

FASTENERS

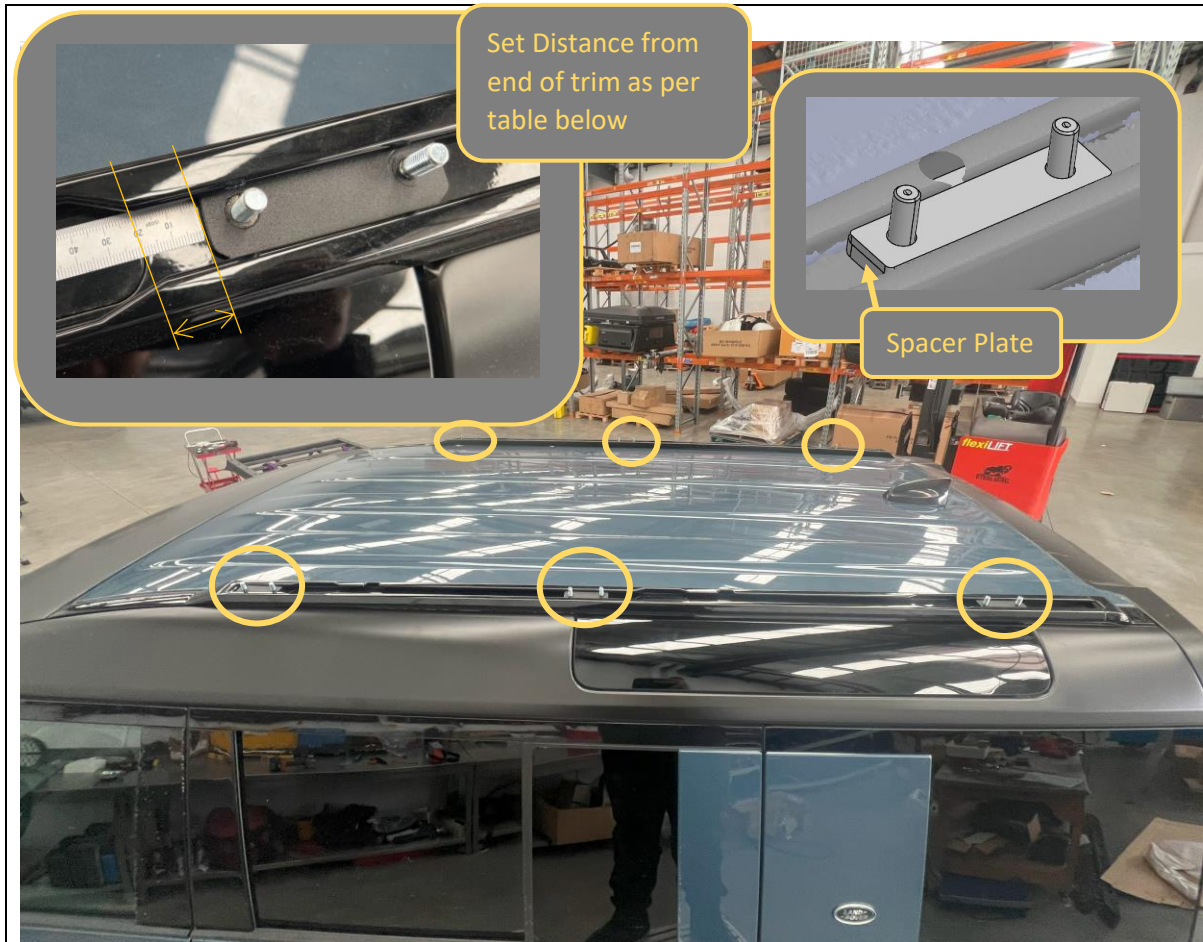

45. Insert the 6x bolt plates into the roof track. There is 1x Plate adjacent to each of the insertion cutouts on the track.
46. Using a ruler to measure the distance from the end of the trim piece below the insertion cutout at the base of the track, set the bolt plates in the following positions.

Mount	Position
Front	5mm Forward
Mid	50mm Forward
Rear	20mm Rear

47. Fit the spacer plates to the bolt plates, ensuring that the bolt plates are sitting centrally in the tracks.

TOOLS REQUIRED

Ruler / Tape Measure

FASTENERS

6x Bolt Plates



- 48. With assistance, either using mechanical aid like a forklift or other people (minimum 4x person lift recommended), lift the rack onto the vehicle.
- 49. As the rack is lowered manipulate the feet such that they lower over the bolt plates in the track.

TOOLS REQUIRED

Lifting equipment
Or
Other technicians
(4 person lift)

FASTENERS



50. Position rack such that the front edge of the front mount cutout in the side rail sits in line with trim seam in the roof rack.
51. Ensure the rack is square to the vehicle and positioned evenly from left to right.

TOOLS REQUIRED

5MM Hex Key

FASTENERS

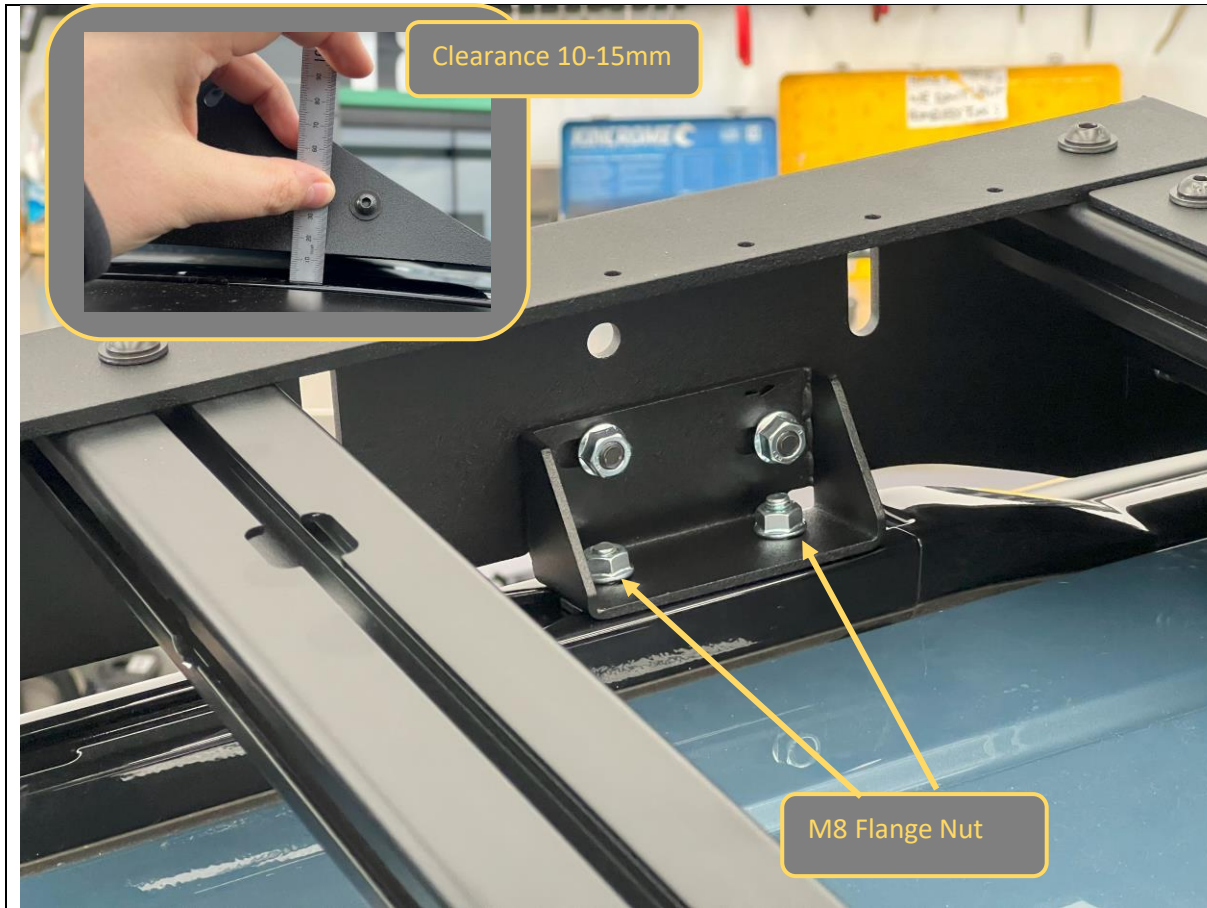

52. Secure the rack to the roof track, using M8 flange nuts onto the bolt plates. Hand tighten only.
53. Adjust the height of the front of the rack to sit with approximately 10-15mm clearance to roof track trim, then **tighten all** the foot to side arm bolts using 5mm hex key.

TOOLS REQUIRED

13mm Spanner
5mm Hex Key

FASTENERS

12xM8 Flange Nuts

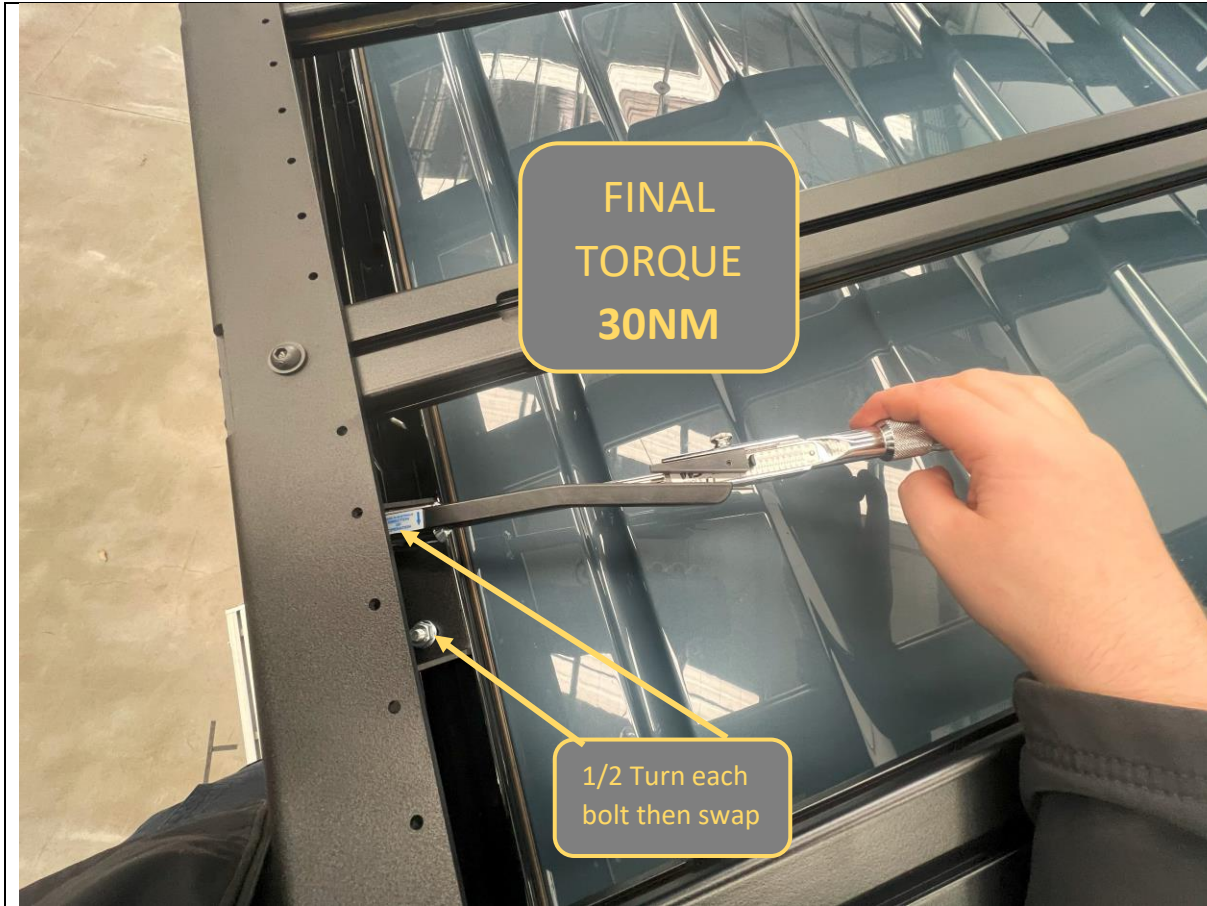

54. Using a torque wrench and 13mm socket Tighten the Track mounting nuts. Progressively tighten each nut on the mount ½ turn, swapping between until target torque of **30NM** achieved on each bolt.

55. Tighten one mount at a time using this sequence using Torque Wrench until **30NM** torque is achieved on all bolts. Crow foot sockets will be needed on the front mount bolts

TOOLS REQUIRED

Torque Wrench
13mm Socket
13mm Crow foot Socket

FASTENERS



56. Double check all fasteners are tight.

57. With that you are done! Load up and head bush and enjoy your new rack!

For contact details see www.offroadanimal.com