



## Land Rover Defender L663 Predator & Toro Front Bar Fitting Instruction

### **IMPORTANT! – READ BEFORE INSTALLATION**

- **NOT SUITABLE for vehicles equipped with front mounted center radiator electric fan!**
- When installed in accordance with these instructions, the front protection bar does not affect the operation of the vehicles SRS airbags.
- This product must be installed exactly as per these instructions using only hardware supplied.
- Take a few moments to read instructions thoroughly before beginning work.
- In the event of damage to any bar component please contact OFFROAD ANIMAL to arrange repair/replacement of components.
- Do not use this product for any vehicle make or model other than that specified on these instructions.
- Do not remove labels from this product.
- This product and its fixings must not be modified in any way unless stated in these fitting instructions.
- The installation of this product is recommended for trained personnel.
- These instructions are correct at time of publication. OFFROAD ANIMAL cannot be held responsible for the impact of any changes subsequently made by the vehicle manufacturer. If you find something has changed, please contact us to let us know!
- During installation it is the duty of the installer to check correct operation/clearances of all components.
- If Instructions are to be printed for reference in the workshop, it is recommended that they are printed in color, for best legibility.

**Fitting Difficulty 9/10**  
**Approx install time 6-8 Hours**

## PARTS LISTING

**IMPORTANT:** Check all parts are present before beginning work! Contact OFFROAD ANIMAL if something is missing.

### Main Parts – In the Box

Qty	Part Number	Description	Image
<b>1</b>	FB-LDF-L663-20-PR-ASM1	Land Rover Defender L663 Predator Front Bar Weldment	
<b>Or</b>			
<b>1</b>	FB-LDF-L663-20-TOR-ASM1	Land Rover Defender L663 Toro Front Bar Weldment	
<b>1</b>	FB-LDF-L663-20-PR-ASM5L	Defender L663 Side Under panel Assy	
<b>1</b>	FB-LDF-L663-20-PR-ASM5R	Defender L663 Side Under panel Assy	
<b>1</b>	FB-LDF-L663-20-PR-ASM4	L663 Defender Mesh Fairlead Assy	
<b>1</b>	FB-LDF-L663-20-PR-ASM2L	Land Rover Defender L663 Impact Assembly	
<b>1</b>	FB-LDF-L663-20-PR-ASM2R	Land Rover Defender L663 Impact Assembly	



1	B-1127	L663 Defender Lower Brace Bracket	
1	U-0075	L663 Defender Centre Bash plate	
1	B-1133L	L663 Defender Fog Light Bracket	
1	B-1133R	L663 Defender Fog Light Bracket	
1	B-1134L	L663 Defender Winch Brace Strap	
1	B-1134R	L663 Defender Winch Brace Strap	
1	B-1135	L663 Defender Camera Bracket	
1	B-1157	L663 Defender Number Plate Bracket	
1	B-1158	L663 Defender Pan Brace	
2	P-0353	L663 Defender Aux Tow Plate	

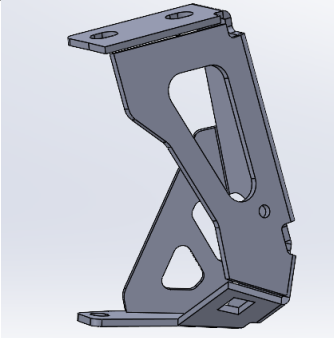
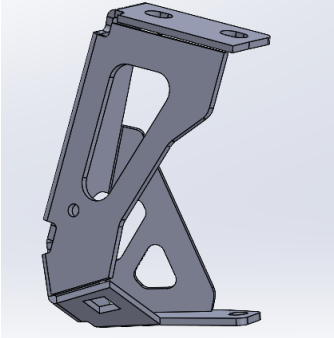
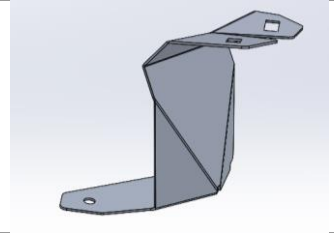
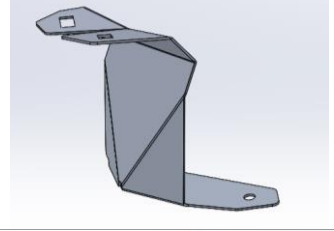
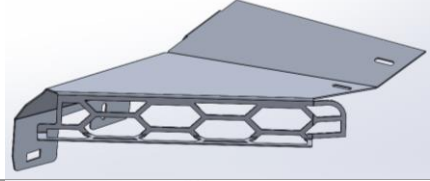
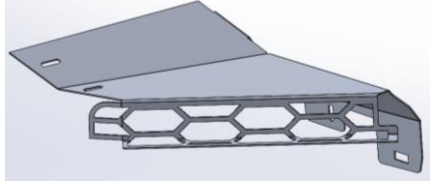
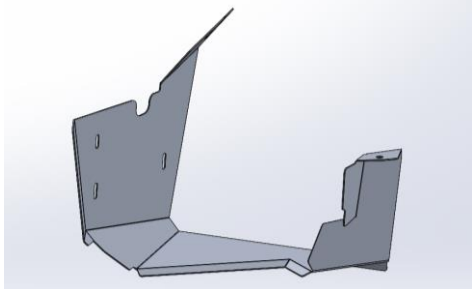

1	B-1132R	L663 Defender Bash Plate Support	
1	B-1132L	L663 Defender Bash Plate Support	
1	B-1269L	L663 Defender Aux Rad Top Outer Air guide	
1	B-1269R	L663 Defender Aux Rad Top Outer Air guide	
1	B-1270L	L663 Defender Aux Rad Top Inner Air guide	
1	B-1270R	L663 Defender Aux Rad Top Inner Air guide	
1	B-1271L	L663 Defender Aux Radiator Lower Air guide	



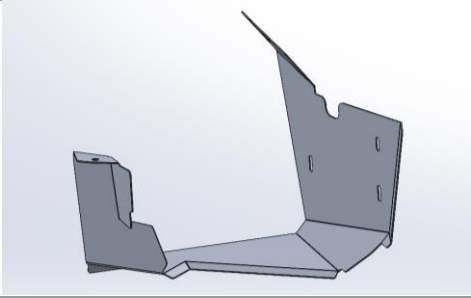
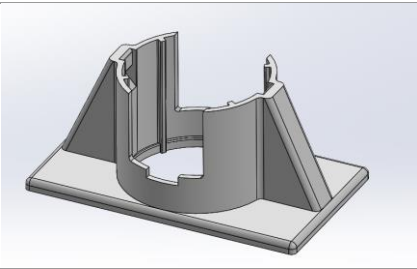

1	B-1271R	L663 Defender Aux Radiator Lower Air guide	
1	PWS-TOP-1000	Pinch Weld PWS51T - Top Bulb Seal 1000mm	No Image
1	PWS-SIDE-500	Pinch Weld PWS53S - Side Bulb Seal 500mm	No Image
6	F-0015	Bosch type Sensor Holder - Straight	
1	TK-COM-PSEN-6	Tape Kit - 6 Sensor Universal	No Image



## Predator Small Parts – Contained in Small Parts Kit Bag

QTY.	PART NO.	DESCRIPTION
39	M6x16 BHCS BLACK ZINC	SCREW, BUTTON HEAD CAP, M6X16X1 GR12.9, ISO4042 ZnNi BLACK PASSIVATED FINISH
55	M6 FLAT WASHER BLACK ZINC	M6 Flat Washer, 12x6.1x1, ISO4042 ZnNi BLACK PASSIVATED FINISH
17	M6 FLANGE NUT	Flange Nut, M6x1 G8.8 ZP
18	M6CN3MM	CAGE NUT M6x2.6-3.5
2	M8 X 16 BHCS BZP	SCREW, BUTTON HEAD CAP, M8X16X1.25 GR12.9, ISO4042 ZnNi BLACK PASSIVATED FINISH
2	M8 FLAT WASHER- BLACK ZINC	M8 FLAT WASHER, 16.5x8.4x1.2, ISO4042 ZnNi BLACK PASSIVATED FINISH
12	M8 HD FLAT WASHER - BZP	M8 FLAT WASHER - High Tensile 19x8x2mm, ISO4042 ZnNi BLACK PASSIVATED FINISH
2	M8 X 20 BHCS BLACK ZINC	SCREW, BUTTON HEAD CAP, M8X20X1.25, ISO4042 ZnNi BLACK PASSIVATED FINISH
4	M8 X 20 HEX	Bolt Hex, M8X20x1.25, GR8.8 ZP
6	M8 FLAT WASHER	M8 FW
8	M10 X 45	Bolt Hex, M10X45X1.5, GR8.8 ZP
8	M10 Flat Washer	M10 FW
16	M10 FLANGE NUT	Flange Nut, M10x1.5 G8.8 ZP
8	M10 x 25	Bolt Hex, M10X25x[1.5], GR8.8 ZP
10	M10 FW LHD	WASHER, FLAT M10X28.5X2.5
2	M5 Flat washer BZP	M5 Flat Washer, 10x5.3x1, ISO4042 ZnNi BLACK PASSIVATED FINISH
2	M5X15 BHCS BZP	SCREW, BUTTON HEAD CAP, M5X15X0.8 GR12.9 ISO4042 ZnNi BLACK PASSIVATED FINISH
2	M8 NYW	Washer, M8, Nylon
2	M8 NYLOC	NYLOC SELF LOCKING NUT, ST STL A2 ISO
8	M12X30	Bolt Hex, M12X30x1.75, GR8.8 ZP
8	M12 FW LHD	M12 FW Large Heavy Duty
8	M12 FLANGE NUT	Flange Nut, M12x1.75 G8.8 ZP
6	M8 FLANGE NUT	Flange Nut, M8x1.25 G8.8 ZP
16	M6x20 BHCS BLACK ZINC	SCREW, BUTTON HEAD CAP, M6X20X1 GR12.9, ISO4042 ZnNi BLACK PASSIVATED FINISH



<b>10</b>	M8 X 30 BHCS BLACK ZINC	SCREW, BUTTON HEAD CAP, M8X30X1.25, ISO4042 ZnNi BLACK PASSIVATED FINISH
<b>8</b>	M6CN2MM	CAGE NUT M6x1.6-2.5
<b>2</b>	M8 Cage nut	NUT, CAGE, M8X1.25 ZINC PLATE
<b>4</b>	M12 FLAT WASHER	M12 FW
<b>4</b>	M12X40	Bolt Hex, M12X40X1.75, GR8.8 ZP
<b>4</b>	NP-COM-M12-40-ASM0	M12 NUT PLATE SHORT, 40MM STEM ROUNDED
<b>2</b>	P-0394	8MM Circular Spacer Suit M12 Bolt
<b>2</b>	M10 X 40	Bolt Hex, M10X40X1.5, GR8.8 ZP

### Toro Additional Parts

<b>QTY.</b>	<b>PART NO.</b>	<b>DESCRIPTION</b>
<b>1</b>	B-1177L	L663 Defender Toro Antenna Bracket
<b>1</b>	B-1177R	L663 Defender Toro Antenna Bracket
<b>2</b>	M8 X 20 BHCS BZP	SCREW, BUTTON HEAD CAP, M8X20X1.25 GR12.9, ISO4042 ZnNi BLACK PASSIVATED FINISH
<b>2</b>	M8 FLAT WASHER- BLACK ZINC	M8 FLAT WASHER, 16.5x8.4x1.2, ISO4042 ZnNi BLACK PASSIVATED FINISH



## TOOLS REQUIRED

The following tools will be required to install the product.

<b>Hand Tools</b>	<b>Power Tools</b>	<b>Workshop Supplies</b>
Metric Socket Set 8-19mm Socket Extension Bar Socket Universal Joint Metric Spanner Set 10-19mm Hex (Allen) Key Set 4-6mm Torx Key Set Trim Puller Tool Flat Blade Screwdriver set Phillips Head Screwdriver set Utility Knife Side Cutters Pliers Ruler Torque Wrench	Electric/Air Impact Driver (Optional) Air Hacksaw Or Oscillating Multi Tool Or Angle Grinder Electric Drill + Drill Bit Set	Panel Stand or Soft Blanket Cable Ties Masking Tape Paint Pen Marker Rags Isopropyl Alcohol

# WORKSHOP SAFETY

It is the responsibility of the installer to always complete works in a safe manner. Make sure the following safety equipment is available, and precautions are observed whilst fitting this product.

<p>Hearing Protection</p> 	<p>Always wear ear protection when using power tools.</p>
<p>Eye Protection</p> 	<p>Ensure eye protection is always worn when cutting or drilling.</p>
<p>Manual Handling</p> 	<p>Do not attempt to lift bar assemblies or rock sliders on your own.</p> <p>Always use two people to lift or use mechanical Lifting aid such as hydraulic lifting trolley.</p>
<p>Vehicle Support</p> 	<p>Always ensure vehicle is properly supported when working on it. Do not attempt to fit products whilst suspension work is being carried out. Do not work under a vehicle supported only by a jack.</p>



1. **Look through the grille to check vehicle is not equipped with electric front radiator Fan. This bar is NOT SUITABLE for vehicles equipped with front mounted center radiator electric fan! Contact Offroad Animal before beginning work if front center fan is equipped.**
2. If vehicle is equipped with Air Suspension, raise to offroad height to provide more room to work.
3. Open the Bonnet
4. Remove 4x Clips securing the top edge of radiator shroud. Use trim tool to lift the center section. Once the center section is up, remove clip.
5. Remove the 4x T30 Torx screws securing the bottom edge of the radiator shroud.
6. Remove the radiator shroud
7. Retain all clips and bolts for reassembly

**TOOLS REQUIRED**

Trim Tool  
T30 Torx Screwdriver

**FASTENERS**

Retain Factory



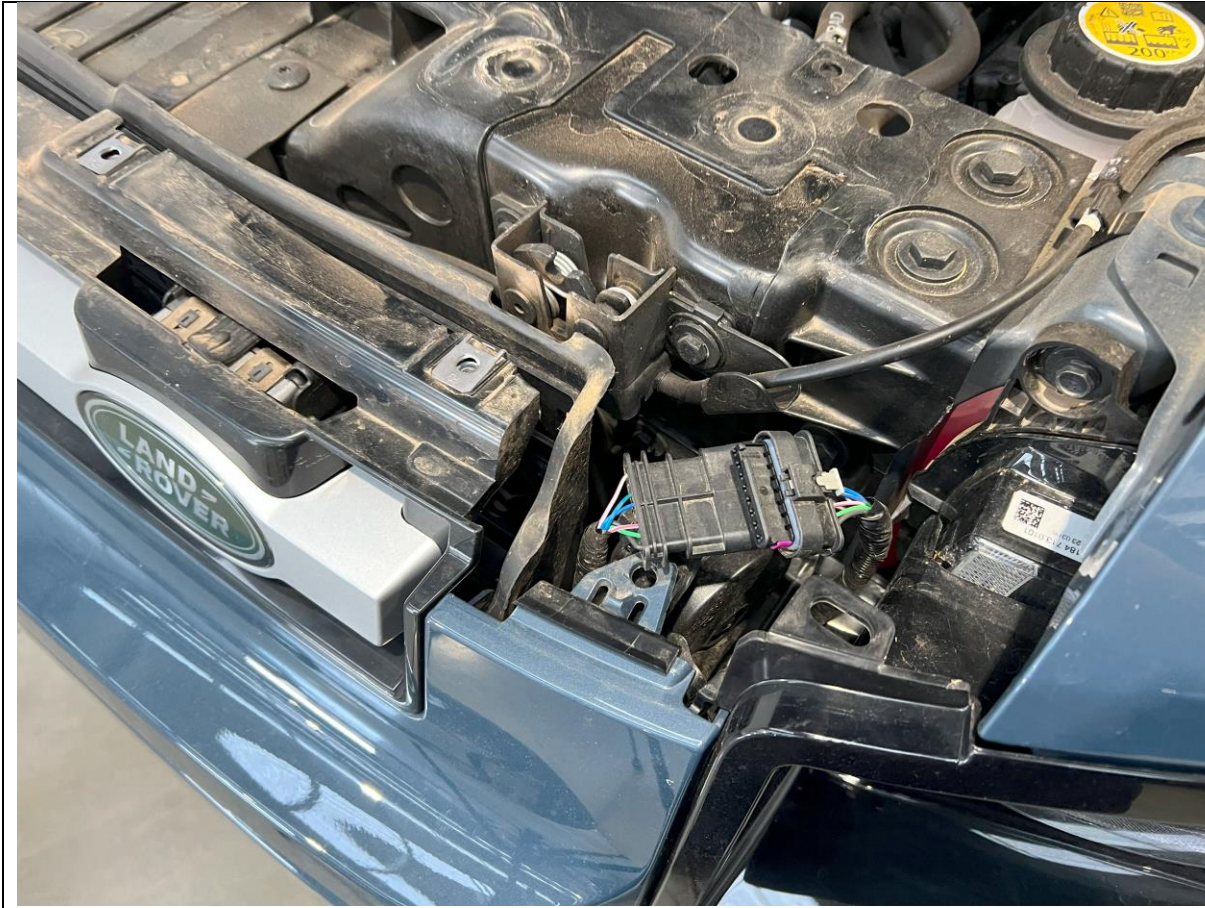

8. Disconnect the radar electrical harness connector, Located near the top of the LH headlight.

**TOOLS REQUIRED**

**FASTENERS**

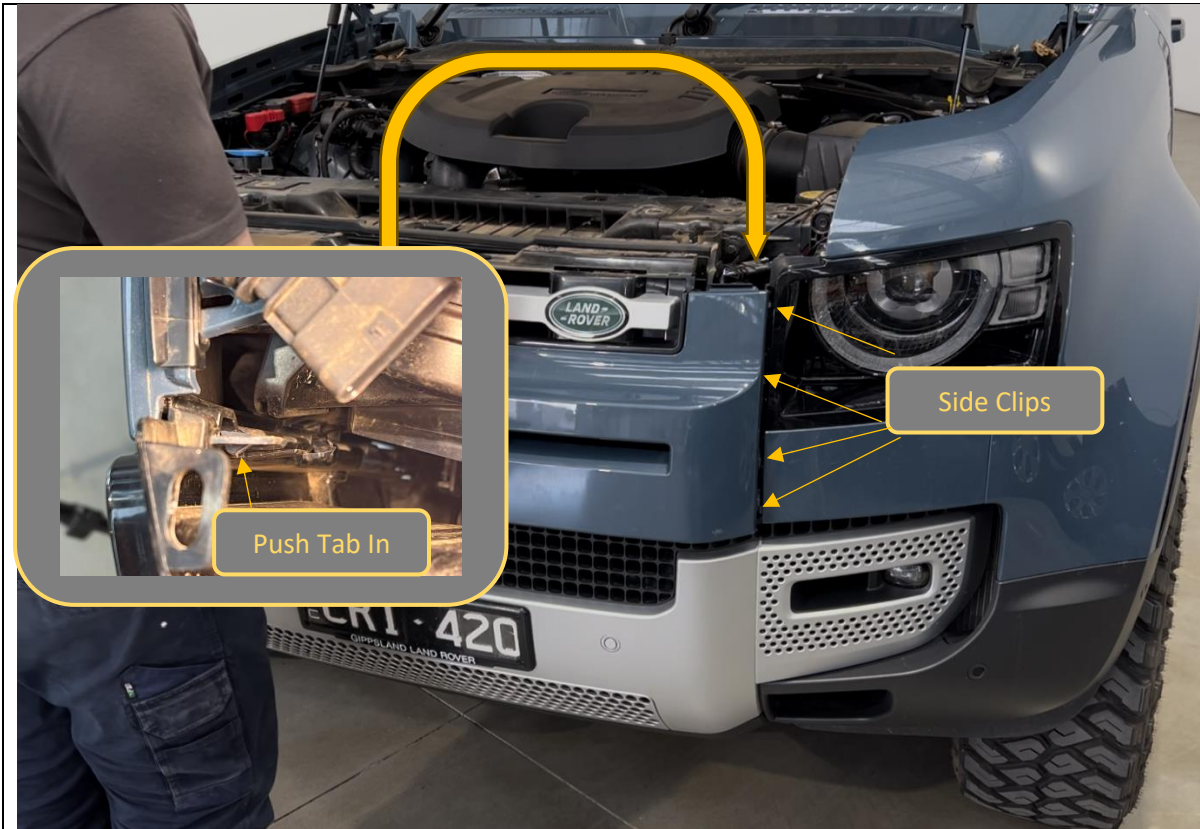

<p>9. There are 4x clips securing each side of the grille. Working from the top push in the center tab (with a finger or trim tool) whilst pulling the grille away from the car. Alternate LH and RH sides as you release clips.</p>	<p><b>TOOLS REQUIRED</b></p> <p>Plastic Trim Tool</p>
<p>10. There are also clips across the bottom that can be released by prying from underneath with plastic trim tool</p> <p>11. Once clips are released, remove grille from car and set aside for re-fitment later.</p>	<p><b>FASTENERS</b></p>



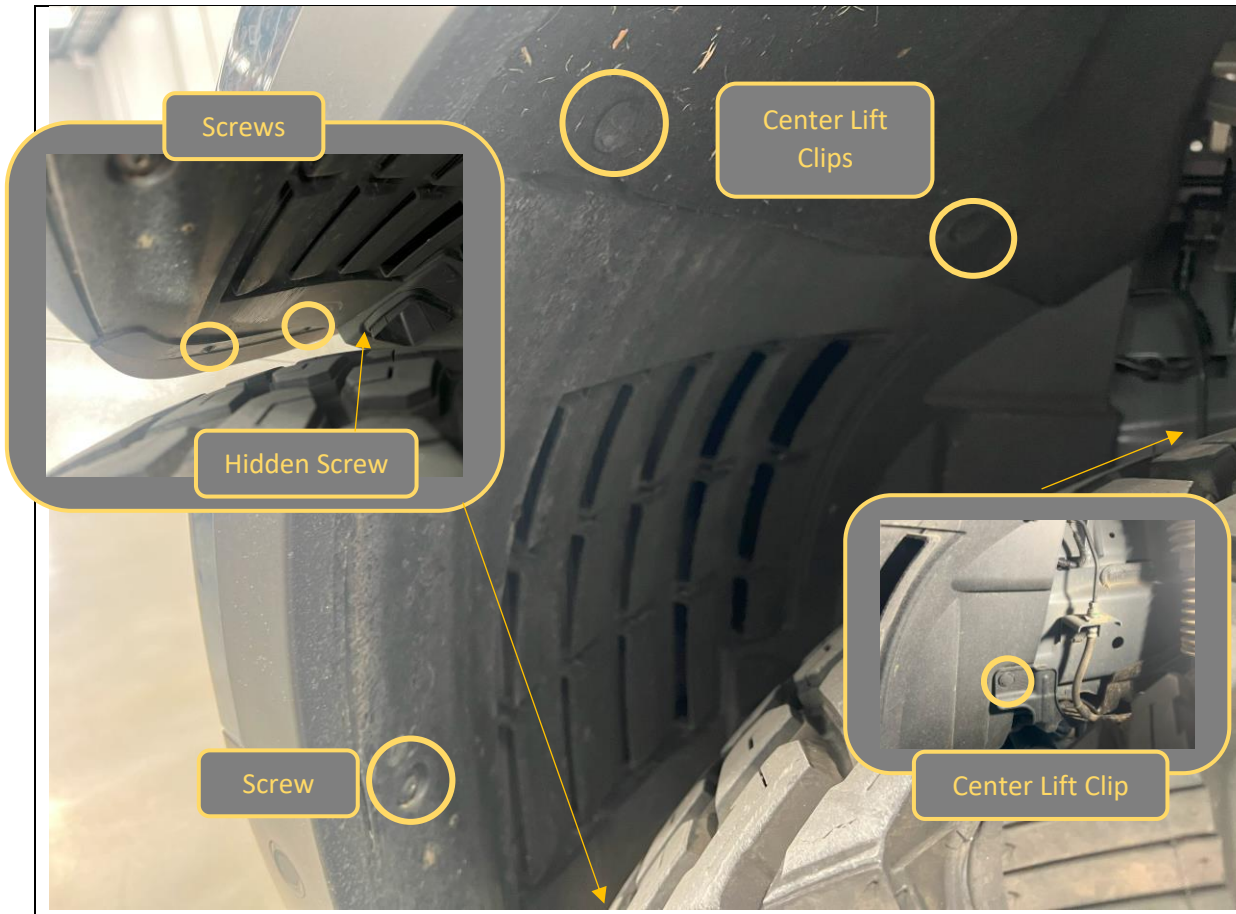

12. Remove the 4 Posidrive screws securing the inner wheel arch liner to the bumper
13. Remove 3x center lift clips securing the top and side of the inner arch liner.
14. Remove the inner wheel arch liner from the vehicle.
15. Complete for both sides of the vehicle.

**TOOLS REQUIRED**

Trim Tool  
Posidrive Screwdriver

**FASTENERS**

Factory Screws (Discard)  
Factory Clips (Retain)

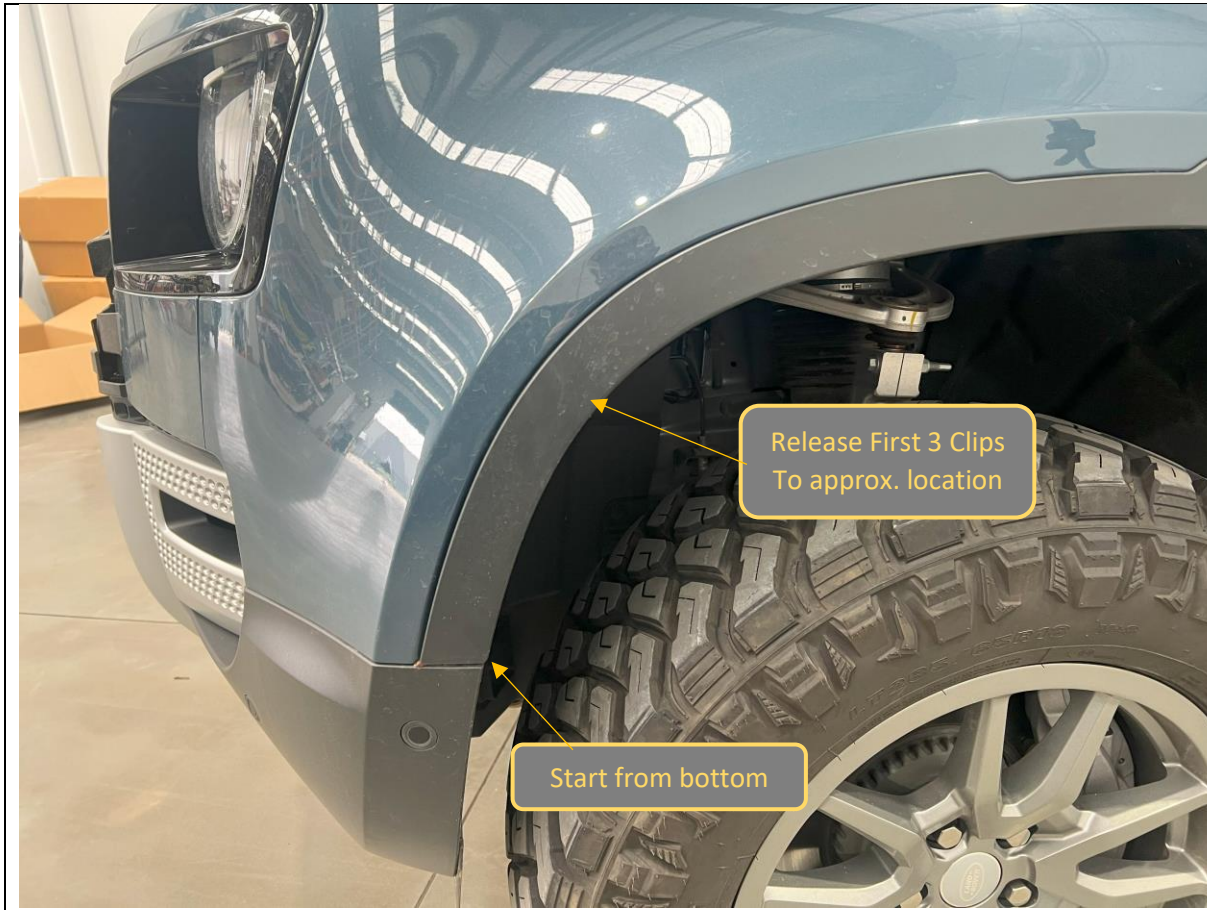

16. Starting from the bottom edge of the wheel arch flare trim, unclip the first 3 clips securing to the fender by pulling the trim away from the fender.
17. These clips are very easy to break, It can be helpful to pinch the clips from behind with pliers or similar to help release.
18. Repeat on both sides of the vehicle.

**TOOLS REQUIRED**

Trim Tool  
Pliers

**FASTENERS**



19. Using trim tool, release the main wiring harness from clips securing it to the bumper.
20. Disconnect the main wiring harness and front camera connector. Take care disconnecting the camera, making sure you pull straight, as it is easy to damage the delicate center pin in the mini co-axial connector.

**TOOLS REQUIRED**

Trim Tool

**FASTENERS**



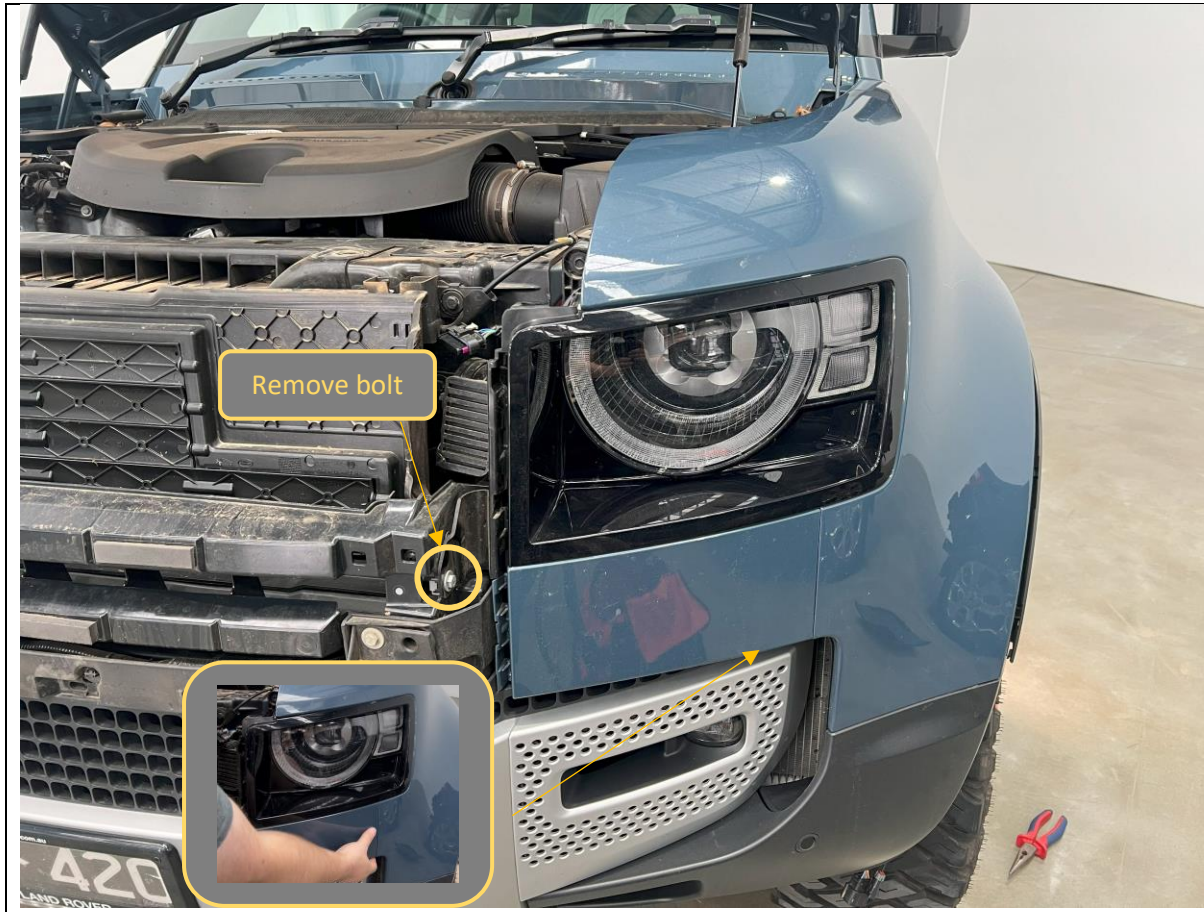

21. Remove the 10mm head bolt securing the headlight surround trims to the radiator support panel.
22. Starting from the bottom corner carefully but firmly pull the trim away from the vehicle to release the clips.
23. Work progressively around the panel until all clips are released, then remove the panel.
24. Repeat for the other side of the vehicle.

**TOOLS REQUIRED**

Trim Tool  
10MM Socket

**FASTENERS**

Factory Clips  
Factory Bolt - Retain

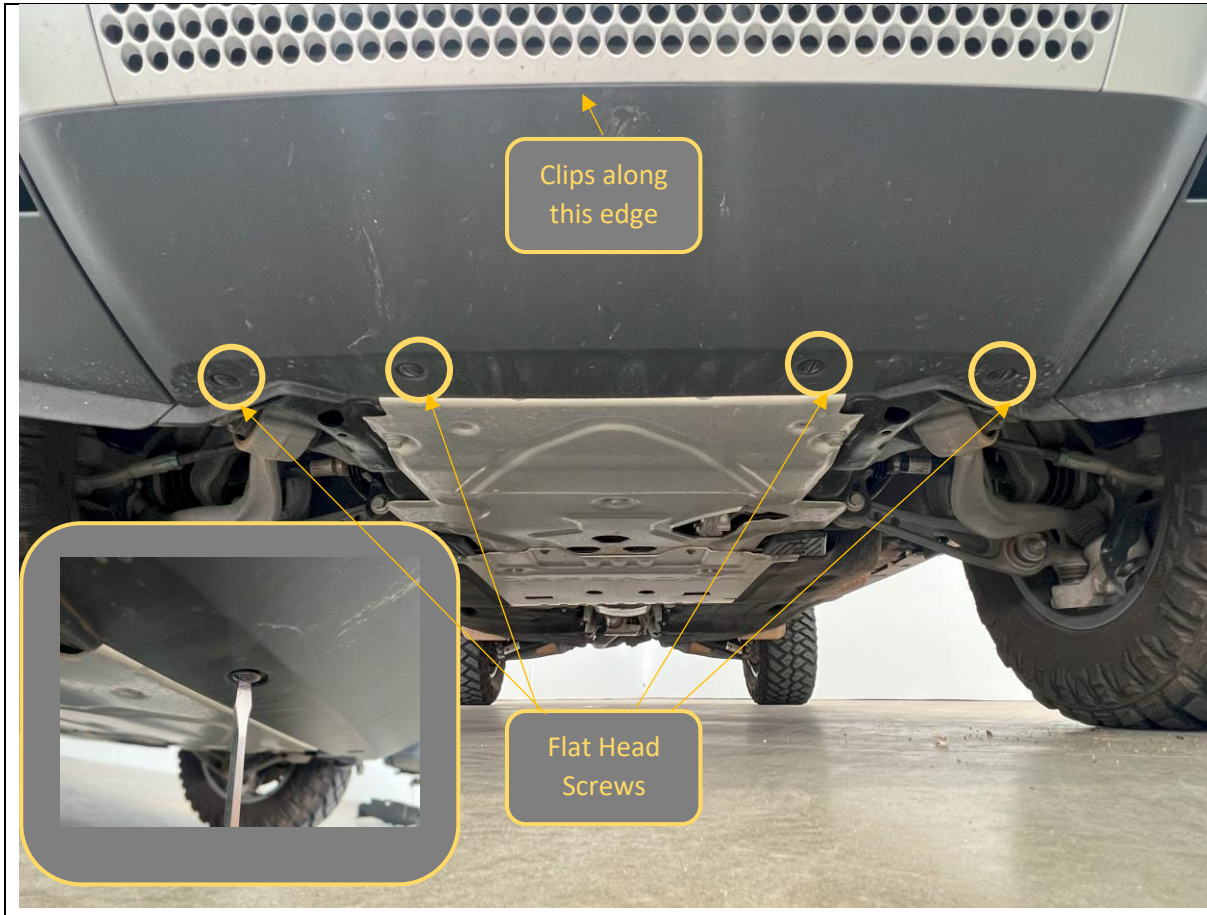

25. On the underside at the front of the bumper, remove the 4x flat head screws that hold the recovery point cover to the bumper.
26. Firmly but carefully pull the panel forward to release panel from the clips on the front edge

**TOOLS REQUIRED**

Flat head screwdriver

**FASTENERS**

Factory Fasteners - Discard



27. Using T30 Torx Screwdriver Remove the 4x Torx head screws securing the bottom of the bumper to the vehicle.

**TOOLS REQUIRED**

**FASTENERS**





28. Remove the 5x 10mm head bolts securing the top edge of the bumper to the vehicle.

(The bolts have been removed already in this photo)

**TOOLS REQUIRED**  
10mm Socket / Spanner

**FASTENERS**



29. Starting from the wheel arch firmly but carefully pull the bumper away from the retaining clips on the fender.
30. With assistance, complete clip release on both sides simultaneously. Once released, the bumper will be free to remove and set aside.

**TOOLS REQUIRED**

**FASTENERS**



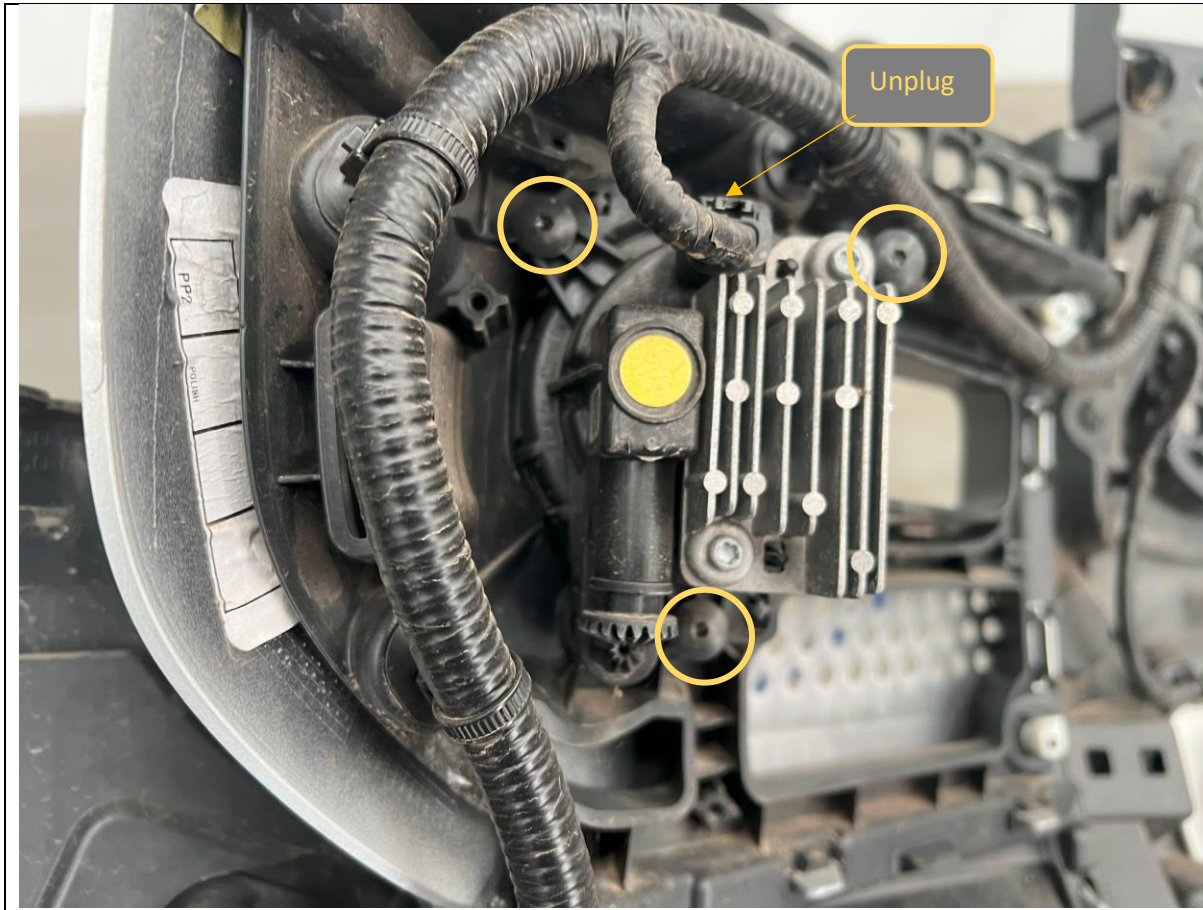

31. If equipped, unplug the fog light harness from the fog lights.
32. Remove the fog light, by removing the 3x Torx screws securing
33. Complete for both sides

**TOOLS REQUIRED**

Torx Screwdriver / Bit

**FASTENERS**

Factory Screws (Discard)

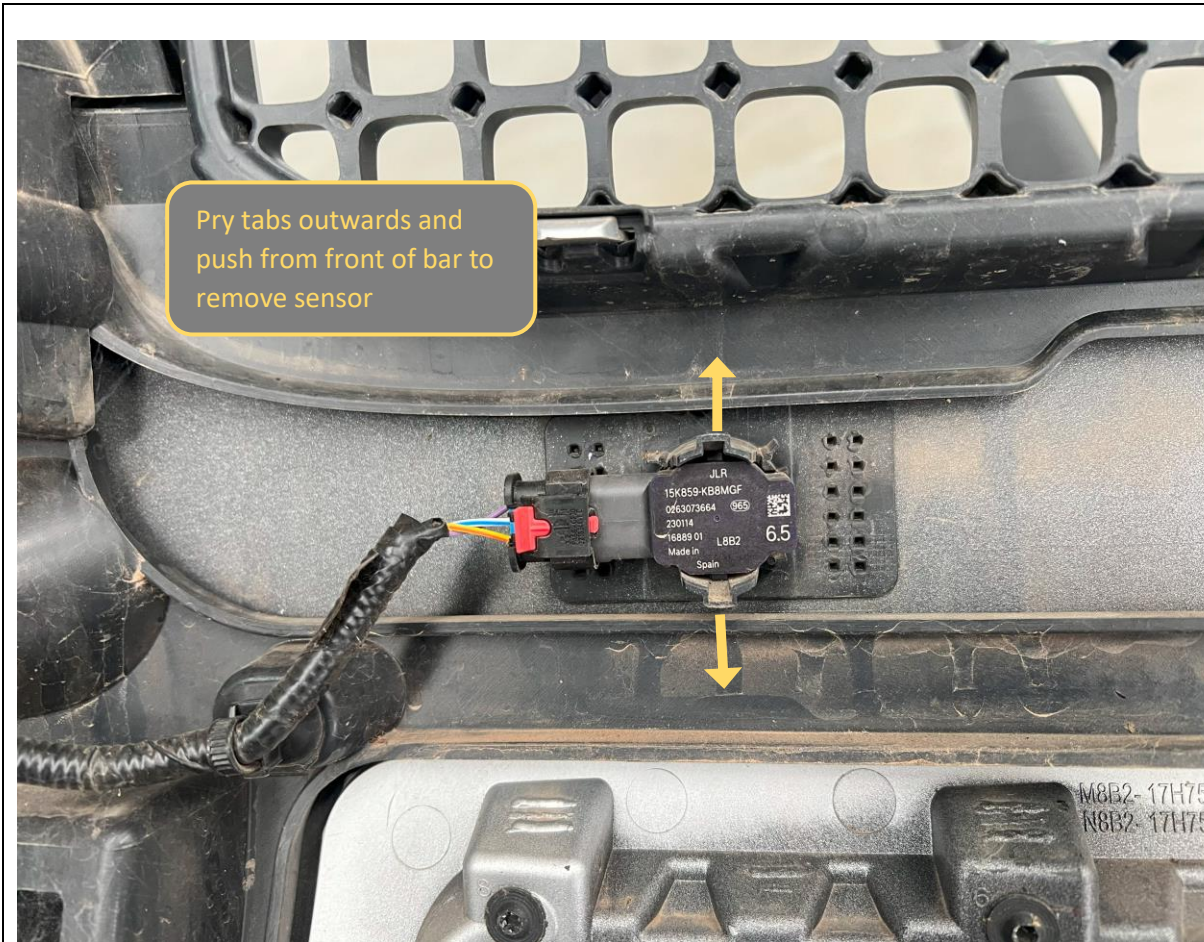

34. Pry the two retaining tabs on the parking sensor housing outwards whilst applying pressure to the face of the sensor from the front side of the bumper. The sensor should be released from the housing. Remove from the rear side of the bumper.

Take care to ensure the rubber isolation rings remain in place with the sensor

35. Complete for all 6 sensors, leave them attached to the loom at this stage.

**TOOLS REQUIRED**

**FASTENERS**





36. Lift the center plastic bar to reveal the 3x Torx screws securing the front camera to the bumper.
37. Remove the 3x Torx screws to release camera.
38. Take note of the correct orientation of the camera. It is helpful to mark this to assist with re-installation to the bar.
39. Carefully disconnect the camera connector, take extra care to ensure you do not twist or bend the connector during removal as it is very easy to damage the delicate center pin on the mini coaxial connector.
40. Place the camera aside in safe place for re-fitment to new front bar.

**TOOLS REQUIRED**

Torx Screwdriver / Bit  
Marker Pen

**FASTENERS**

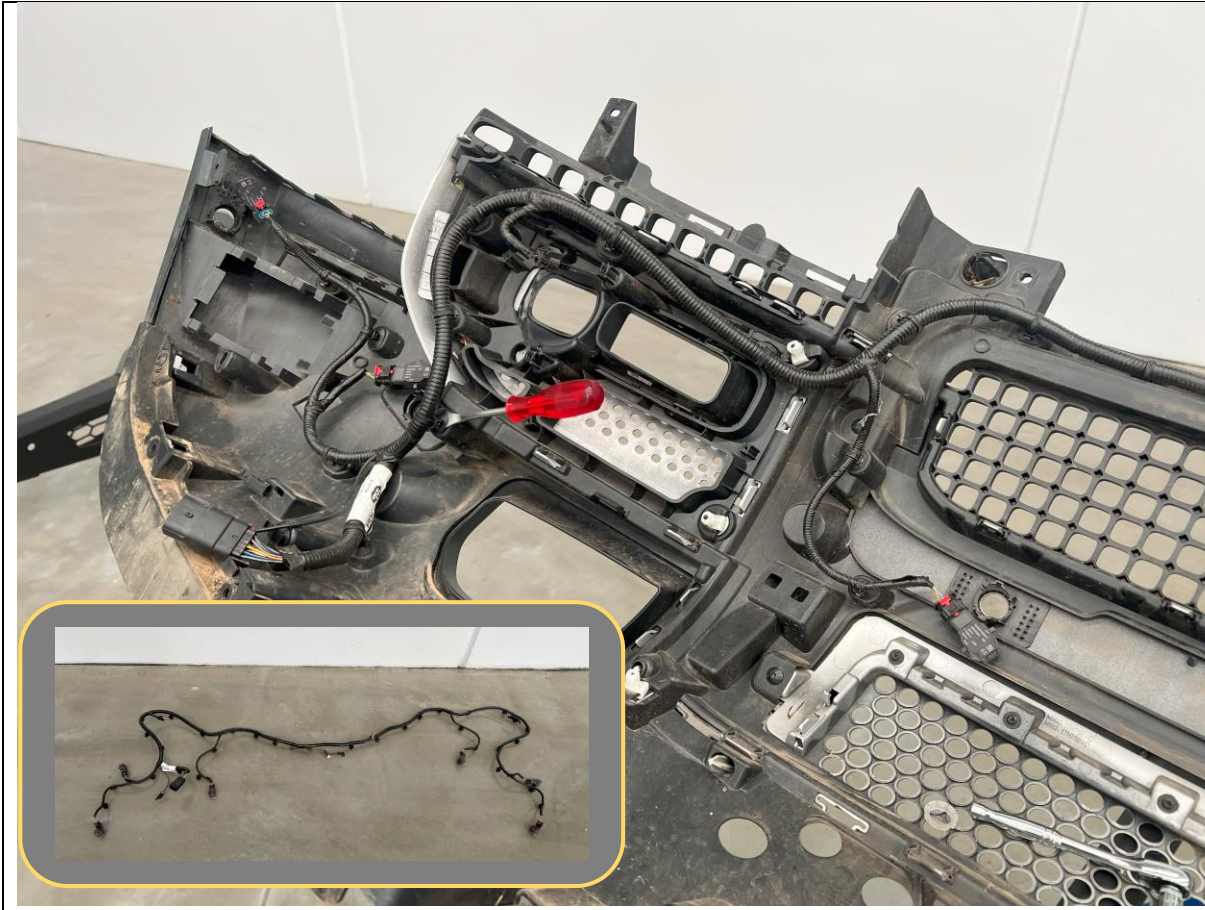

41. Using a trim tool, unclip all the clips securing the wiring harness to the bumper.
42. Remove wiring harness from the bumper and set aside in safe place for re-fitment to the new front bar.

**TOOLS REQUIRED**

Trim Tool

**FASTENERS**

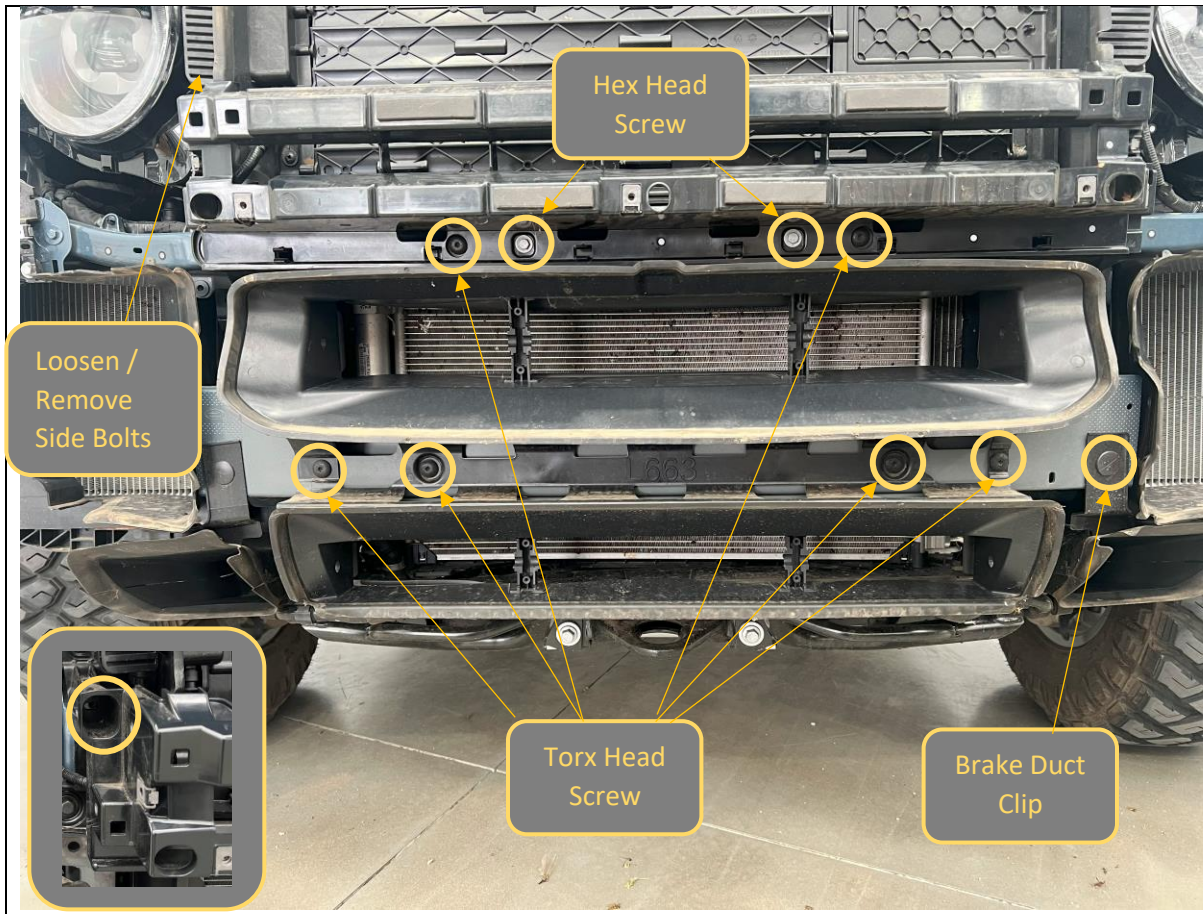

<p>43. Undo the 6x Torx Head and 2x 10mm Hex head screws securing the center air guides.</p> <p>44. Loosen the 2x Bolts (1x Each side) Securing the upper active radiator air guide.</p> <p>45. Remove the lower air guide. It sits underneath the lip of the upper radiator air guide and will need to be manipulated to remove.</p>	<p><b>TOOLS REQUIRED</b> Trim Tool T30 Torx Driver</p>
<p>46. Replace the bolts securing the upper active radiator air guide.</p>	<p><b>FASTENERS</b></p>



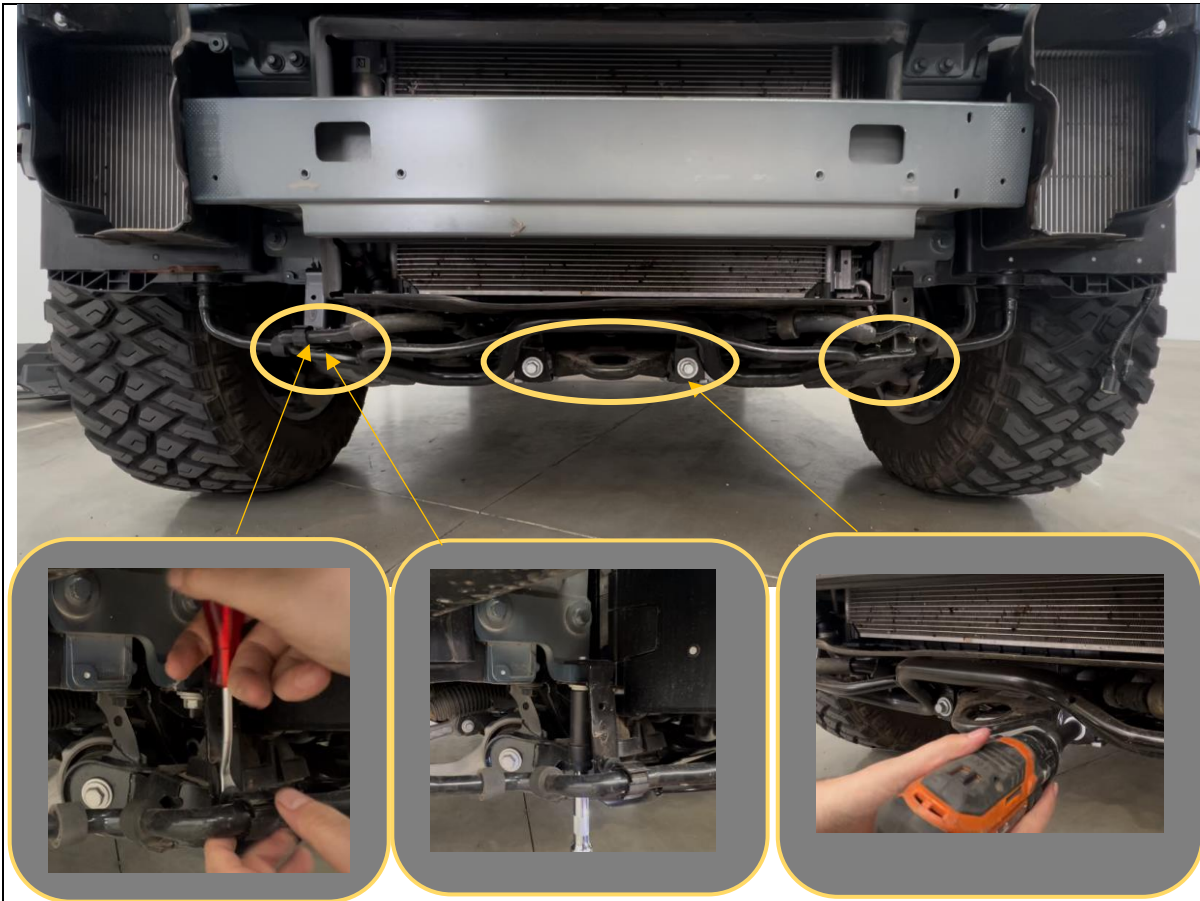

47. Release the clips holding the aux radiator coolant hoses to the tubular lower radiator guard.
48. Remove the Factory bolts securing the tubular lower radiator guard to the factory impact beam using 13mm socket
49. Remove the Factory bolts securing the tubular lower radiator guard to the crossmember using 16mm socket. Remove the

**TOOLS REQUIRED**

13mm Socket  
16mm Socket

**FASTENERS**

Factory 13mm Head Bolt (discard)  
Factory 16mm head bolts (Retain for Refitment)

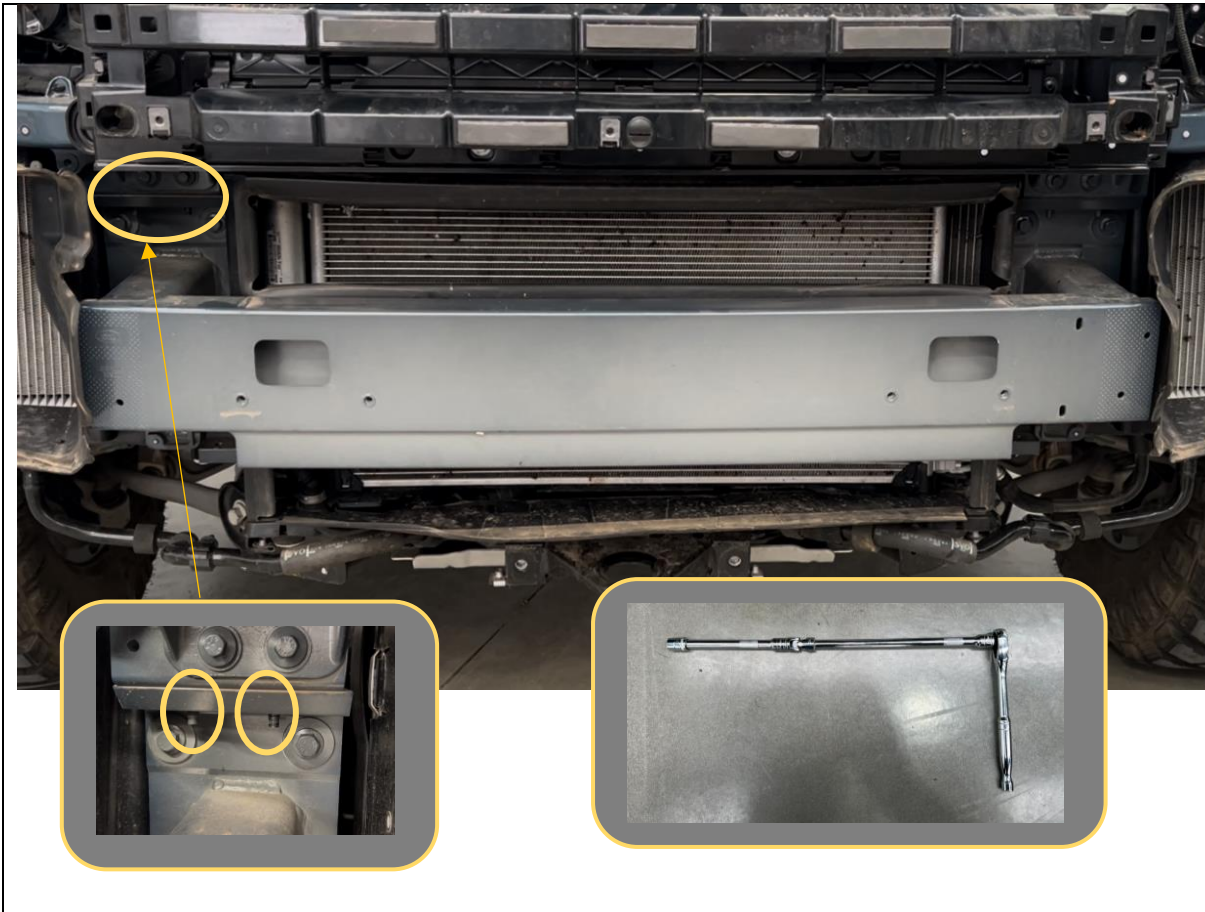

50. It is now time to remove the main impact beam.
51. This is much more difficult than it first appears due to the vertical bolts securing the top edge of the impact beam to the chassis.
52. Gather the required tools to undo these bolts. You will need 3/8" (1/2" is too large) Ratchet, Universal Joint and a mid (approx. 100mm) and Long (approx. 250mm) extension bar, and 10mm socket.

**TOOLS REQUIRED**

- 3/8" Drive Ratchet
- 3/8" Universal Joint
- 3/8" Medium Extension Bar
- 3/8" Long Extension Bar
- 10mm Socket

**FASTENERS**

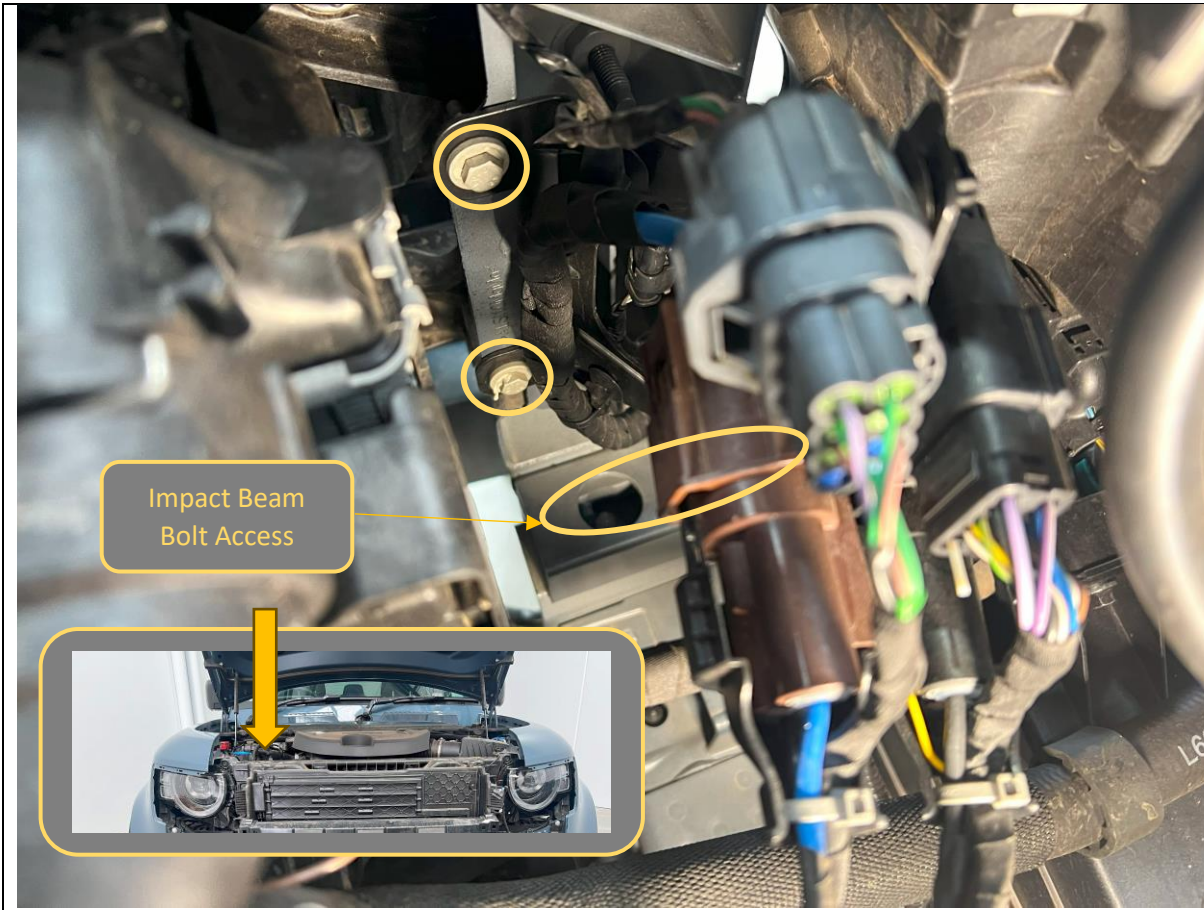

53. On the RHS, in the engine bay adjacent to the headlight locate the wiring harness bracket shown. Below this you will be able to see the bolts that need to be removed to remove the impact bar.
54. Remove the 10mm head screws securing the wiring harness bracket to allow the bracket to be manipulated for better access.

**TOOLS REQUIRED**

10mm Socket  
Extension Bar

**FASTENERS**

Factory Bolts – Retain



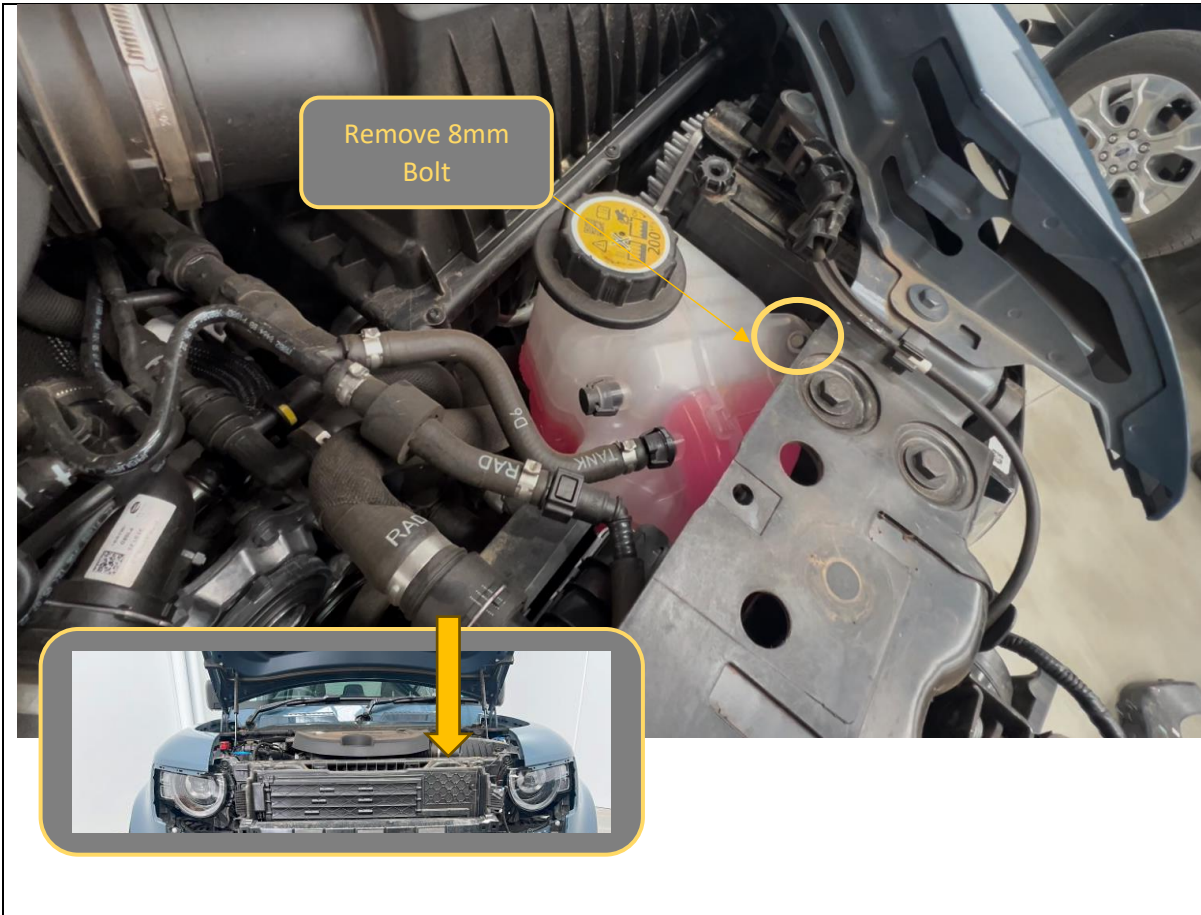

55. On the LHS, the impact beam top bolts are in the same location. This side is obstructed by the coolant overflow tank.
56. Remove the 8mm head screw securing the tank.
57. The tank sits on locating tabs. Lift tank up then rearwards to lift tank off the tabs. Allow tank to sit loosely in position. This will provide a (albeit very limited) access to the impact beam top bolts

**TOOLS REQUIRED**

8mm Socket

**FASTENERS**

Factory Bolt – Retain

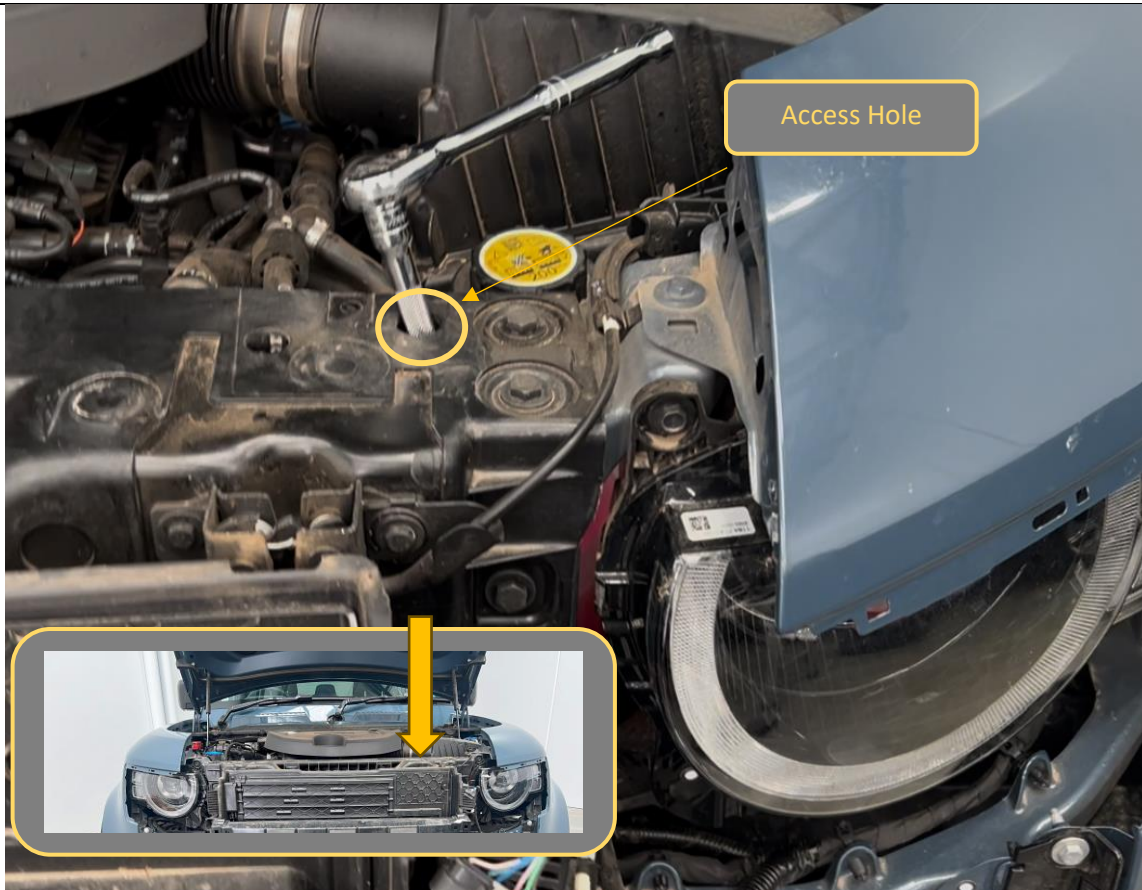

58. Remove the impact beam top bolts.
59. On LHS we found it best to insert the socket through the access holes in the top of the body. Manipulate the tank position as required to get the socket onto the bolts. This is fiddly!
60. Curse out whomever at Land Rover thought this was a good idea...
61. Breathe a big sigh of relief when they are finally out! Retrieve the bolts using magnetic pickup tool.

**TOOLS REQUIRED**

3/8" Extension bar contraption  
10mm socket  
Magnetic Pickup tool

**FASTENERS**

Factory Bolts – Retain

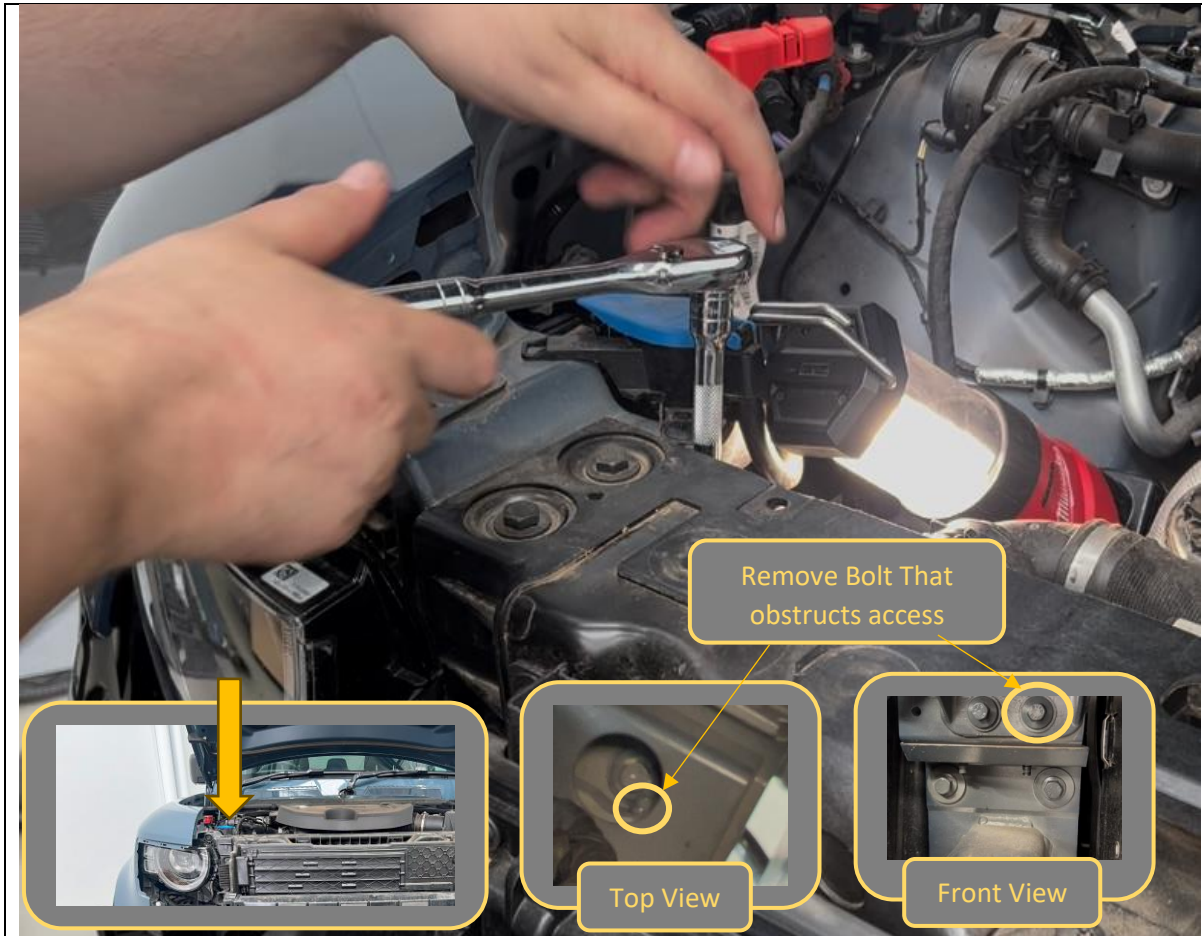

62. On RHS there is a bolt that obstructs access to one of the vertical impact beam bolts. Back out the bolt from the front before starting using 10mm socket
63. On RHS there are no access holes. Manipulate the wiring bracket and the Socket position as required to get the socket onto the bolts. This is fiddly!
64. Again, curse out whomever at Land Rover thought this was a good idea...
65. Breathe a big sigh of relief when they are finally out!
66. Retrieve the bolts using magnetic pickup tool.

#### TOOLS REQUIRED

3/8" Extension bar contraction  
10mm socket  
Magnetic Pickup tool

#### FASTENERS

Factory Bolts – Retain





67. Remove the 8x Factory flange bolts (4 Per side) securing the impact beam to the chassis, using 13mm Socket

68. Remove set aside the impact beam.

**TOOLS REQUIRED**

13 mm Socket

**FASTENERS**



69. Next step is to remove the plastic bumper retainer.
70. Remove the 10mm head factory bolt securing the Aux radiator shroud to the bumper retainer.
71. Remove the 3x 10mm head factory bolts securing the bumper retainer to the fender.
72. Remove the retainer from the fender, it is secured by clips on the back of the fender.
73. Repeat for both sides.

**TOOLS REQUIRED**

10mm socket / spanner  
Trim tool

**FASTENERS**

10mm head factory bolts - Retain

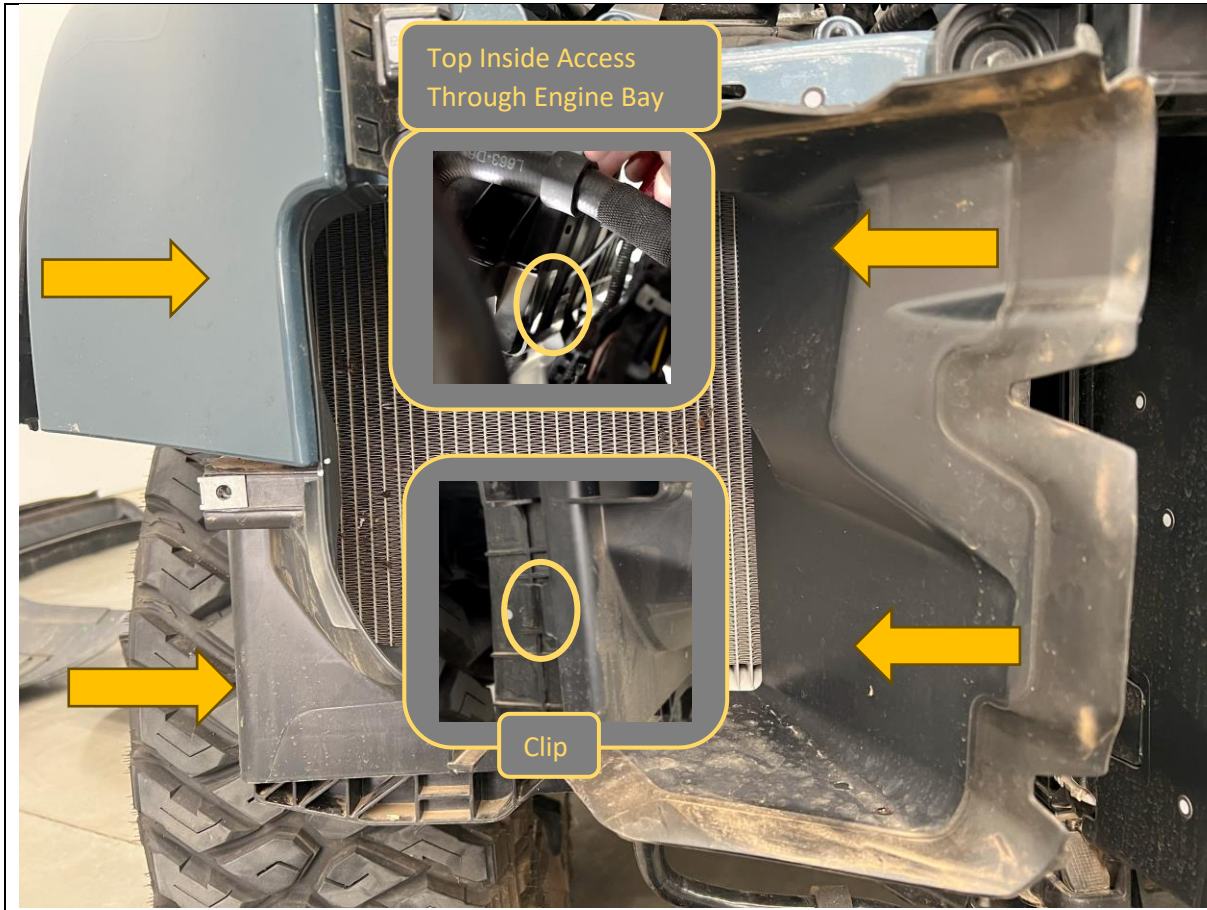

74. Remove the plastic auxiliary radiator air guides. These are clipped onto the radiator supports in 4x places.
75. Use a trim tool to release the clips. The top inner clip is best accessed through the engine bay.
76. Once clips released manipulate the air guide forward and down, past the lip on the fender to remove from the vehicle.
77. Repeat air guide removal for both sides.

**TOOLS REQUIRED**

Trim tool

**FASTENERS**



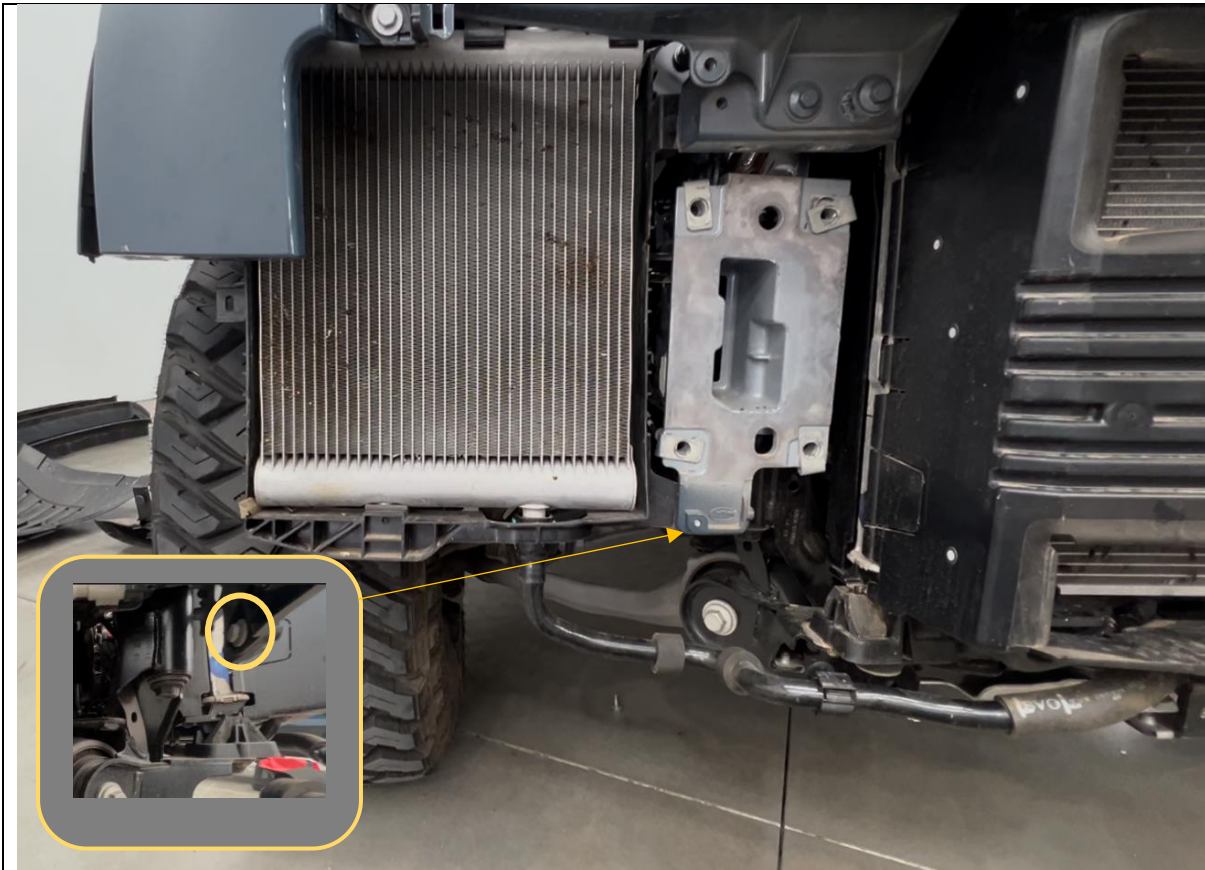

78. Remove the 10mm head factory screw securing the bottom of the plastic radiator support to the chassis. This bolt is accessed from behind.

**TOOLS REQUIRED**

10mm Socket

**FASTENERS**

10mm head Factory Bolt - Retain

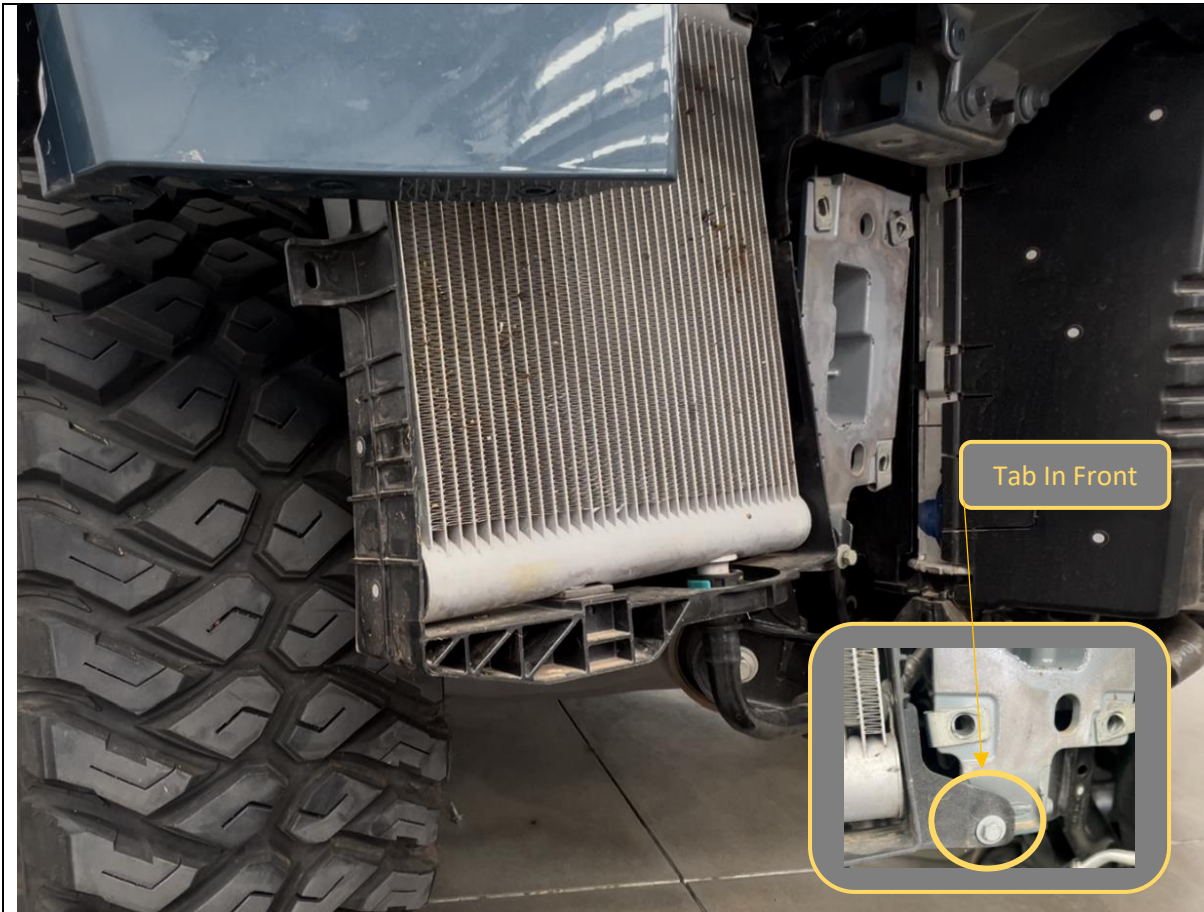

79. Reposition the plastic radiator support such that the plastic tab sits in front of the chassis horn.

Use the flex in the plastic to manipulate the tab around the chassis end.

80. Re-Secure the radiator support to the chassis ends on the front side, using the same factory bolt.

81. Complete for both sides of the vehicle.

**TOOLS REQUIRED**

10mm Socket

**FASTENERS**

Factory Flange Bolts



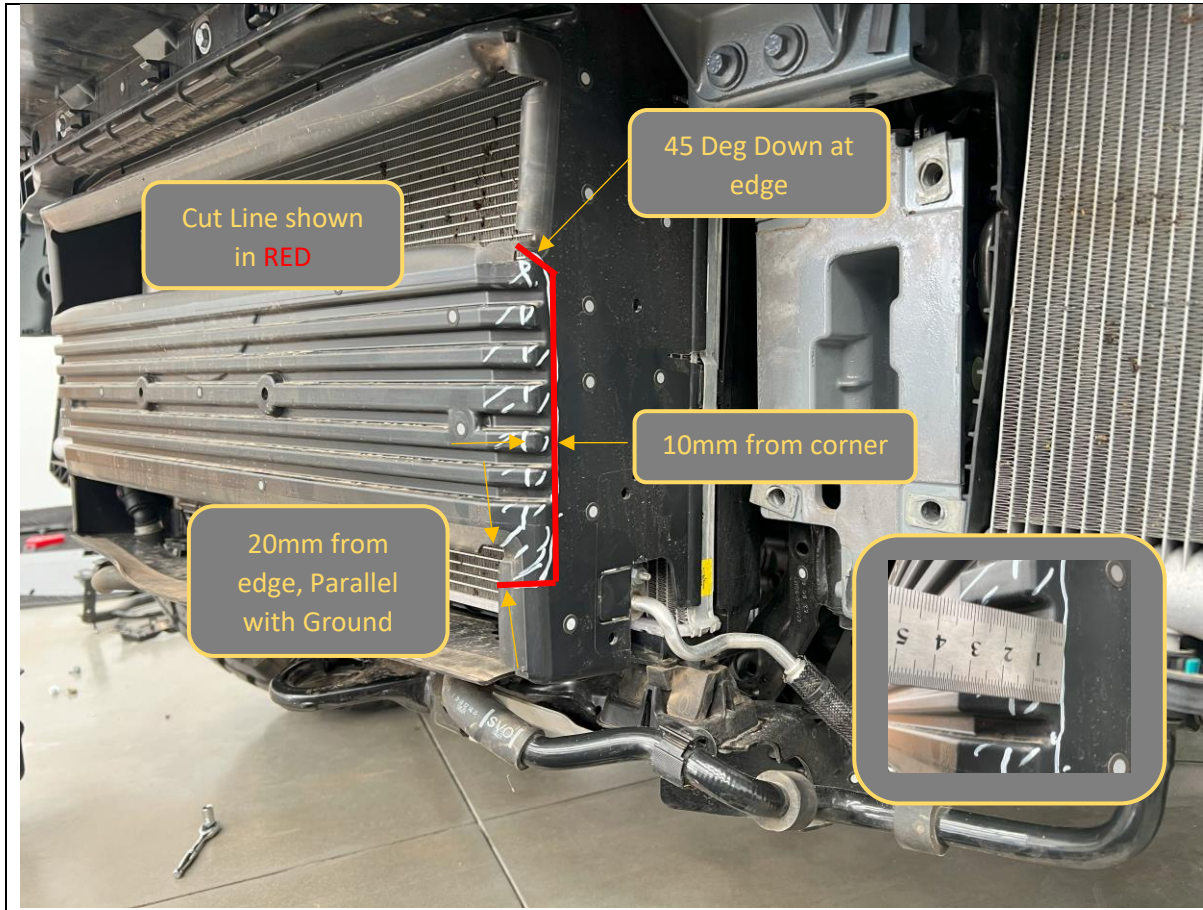

82. Using a ruler and paint marker, mark out the trim for the center radiator air guide as shown in the image above. Mark on both sides of the radiator air guide.

**TOOLS REQUIRED**

Paint Pen  
Ruler

**FASTENERS**



83. Using a sharp utility knife, air hacksaw or oscillating multi tool, carefully cut along marked lines and remove center section of radiator shroud.

**TOOLS REQUIRED**

Utility Knife  
Or  
Oscillating Multi Tool  
Or  
Air Hacksaw

**FASTENERS**



84. Mark out the following trim to remove the triangular shaped section of the outer flange on the plastic radiator support.
85. Mark the cut line level with the flat back side face of the radiator support, and roughly parallel to the front edge of the radiator support.
86. Carefully trim off the marked section using a sharp utility knife, air hacksaw or oscillating multi tool.
87. Repeat the same trim on other side of the vehicle.

**TOOLS REQUIRED**

Paint pen,  
Utility Knife  
Or  
Oscillating Multi Tool  
Or  
Air Hacksaw

**FASTENERS**



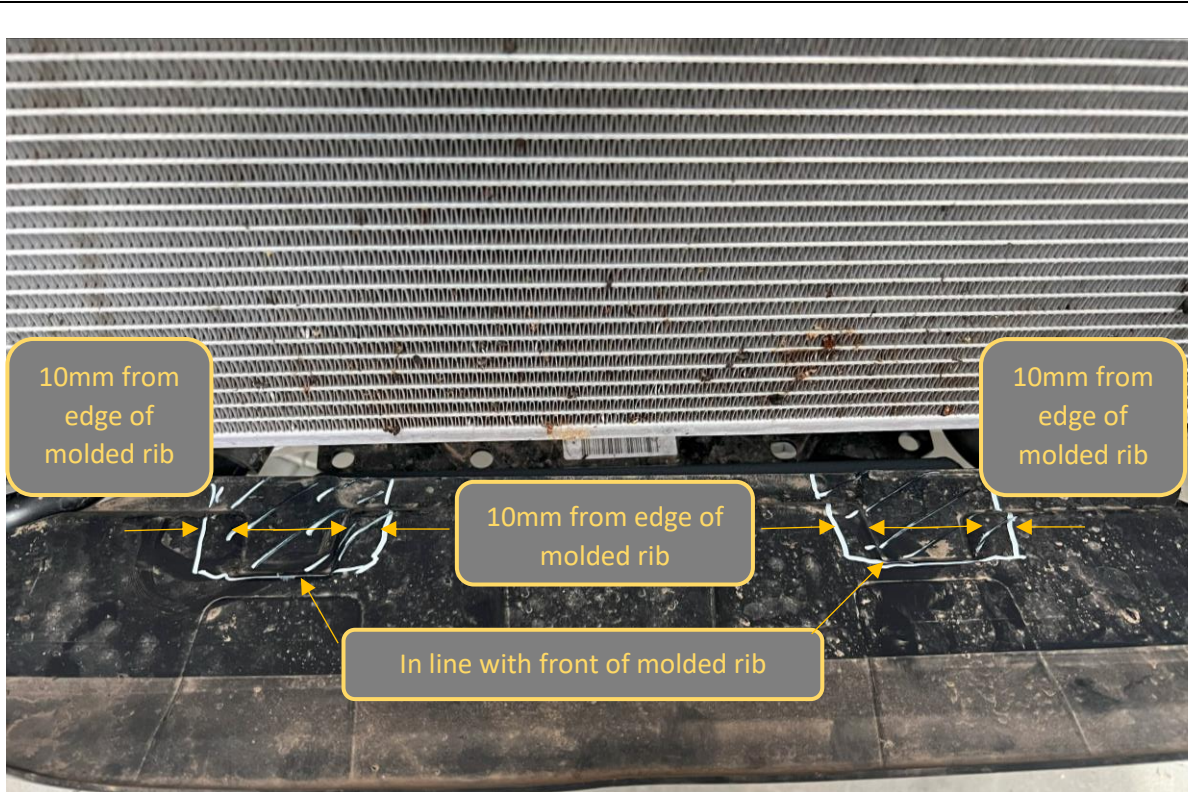

88. Using Paint pen and ruler mark out the following trim in the lower flange of the center radiator air guide panel.
89. Carefully trim off the marked section using a sharp utility knife, air hacksaw or oscillating multi tool.

**TOOLS REQUIRED**

Paint pen,  
Utility Knife  
Or  
Oscillating Multi Tool  
Or  
Air Hacksaw

**FASTENERS**



90. Measure approx. 90mm from the bottom of the fender flares and place masking tape across that location.
91. Using a ruler and marker, measure and mark a point 90mm vertically from the rear corner of the flare on the tape applied earlier.
92. Using the bottom of the fender as reference, mark a line parallel to the bottom of the fender, through the 90mm point just marked.  
  
This is easiest to do by zeroing a digital level on the bottom of the fender, then matching on the flare.
93. Ensure the flare is held as close as possible to the fender when making the mark.

**TOOLS REQUIRED**

Ruler  
Marker  
Digital level or Spirit Level  
Masking Tape

**FASTENERS**



94. Using an Oscillating Multi Tool or Air Hacksaw carefully trim along the line marked, whilst holding the flare away from the fender. Take extra care to ensure this cut is straight and clean.
95. If required the fender flare can be completely removed, by releasing the remaining clips securing it to the fender. This will however increase the time taken and chance of breaking clips.
96. Remove masking tape from cut edge and de-burr if required.
97. Ensure all white clips are present on the back side of the wheel arch flares,
98. Re-clip the wheel arch flare to the fender.
99. Complete steps on both sides.

**TOOLS REQUIRED**

Oscillating Multi Tool  
Or  
Air Hacksaw

**FASTENERS**





100. Finally, it's time to start putting some new bits on!
101. First fit the subframe bracket, using the 2x 16mm head factory flange bolts removed from the tubular radiator guard.
102. Ensure bracket is sitting level, then torque bolts to **90Nm**

**TOOLS REQUIRED**  
16mm Socket  
Torque Wrench

**FASTENERS**  
Factory Flange Bolts (16mm head M12)

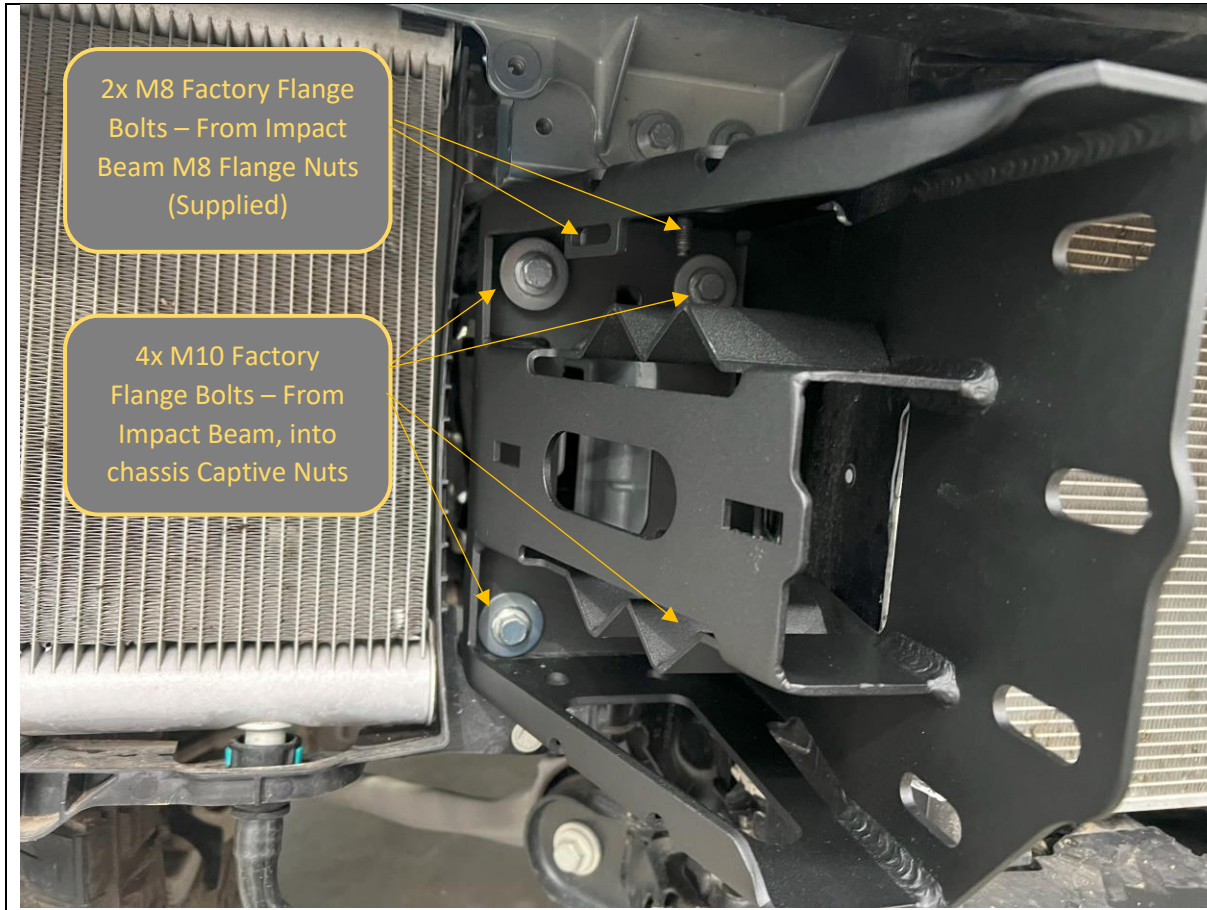

103. Fit the impact assemblies to the chassis, using fasteners shown in the image above. The (awkward!) top bolts need to be lowered from the top (like how they were removed). This can be quite fiddly and is best achieved using a magnet tool or socket with blu-tack to retain the bolt.

104. Leave all bolts loose at this stage.

**TOOLS REQUIRED**

- 3/8" Drive Ratchet
- 3/8" Universal Joint
- 3/8" Medium Extension Bar
- 3/8" Long Extension Bar
- 10mm Socket
- 13mm Socket

**FASTENERS**

- Factory Flange Bolts (14mm head M10)
- Factory Flange bolts (10mm head M8)

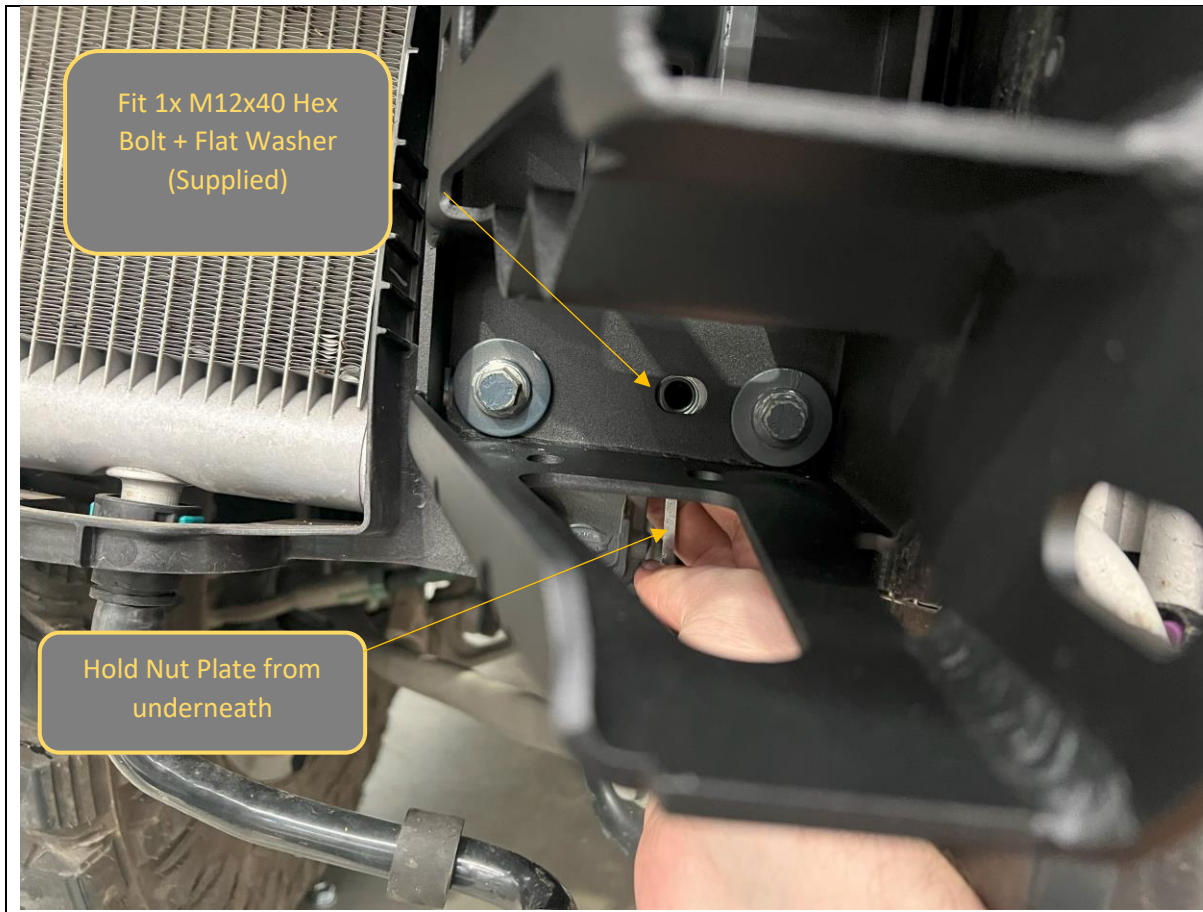

105. Hold one of the M12 short stem nut plates in position behind the bottom of the chassis end. Align with the Lower slot in the impact assembly.
106. Secure with M12x40 Hex Bolt and M12 Flat washer from bolt kit.
107. Leave bolts loose at this stage

**TOOLS REQUIRED**

**FASTENERS**

- 1x M12x40 Hex Bolt
- 1x M12 Flat Washer



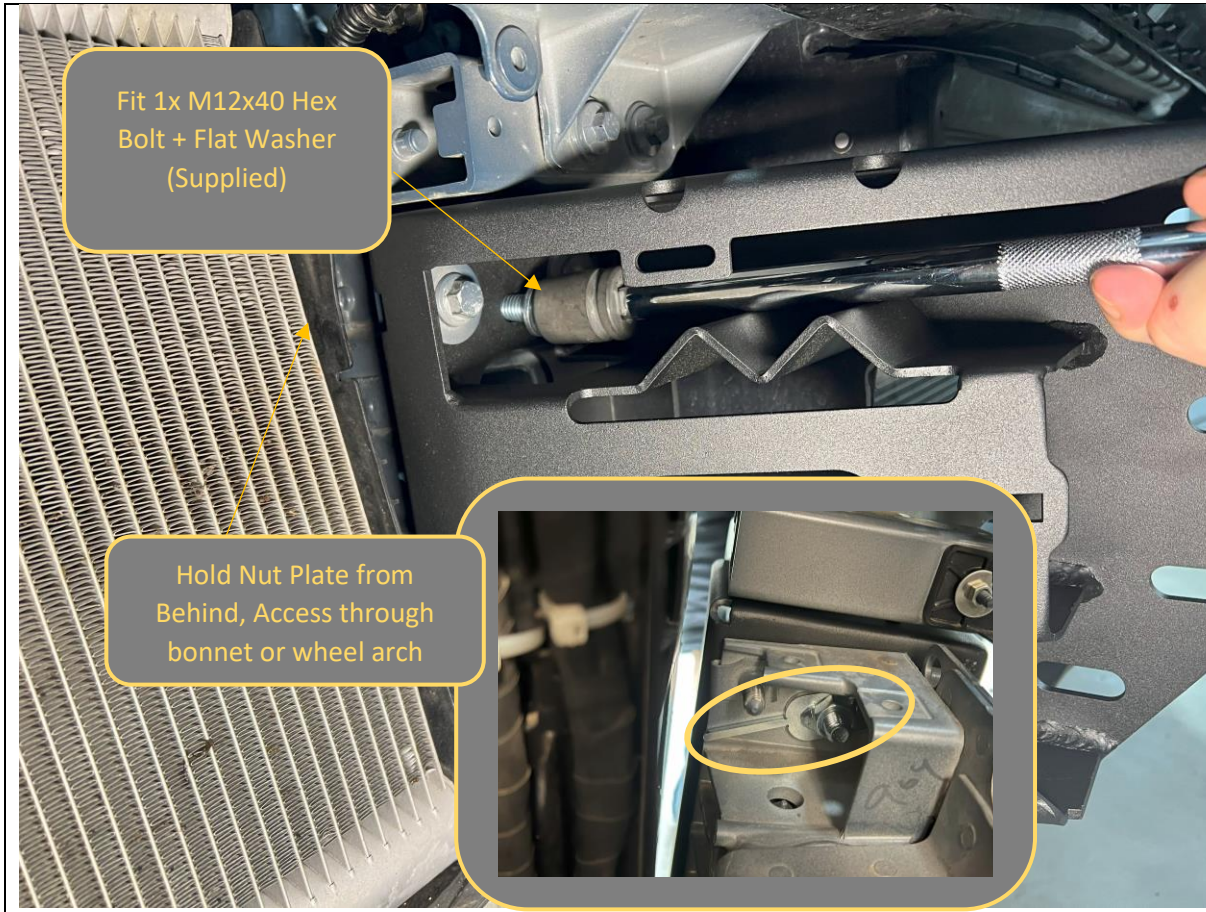

108. With assistance from another person, hold one of the M12 short stem nut plates in position behind the top of the chassis end. This can be accessed from the top via the open bonnet (easier on RHS) or via the wheel arch (easier on LHS where radiator overflow tank block view)

109. Secure with M12x40 Hex Bolt and M12 Flat washer from bolt kit. Use Socket and extension bar to assist placing bolt.

110. Leave bolts loose at this stage

111. Complete fitting of impact assemblies for other side of the vehicle

**TOOLS REQUIRED**  
18/19mm socket  
Extension bar

**FASTENERS**

1x M12x40 Hex Bolt  
1x M12 Flat Washer



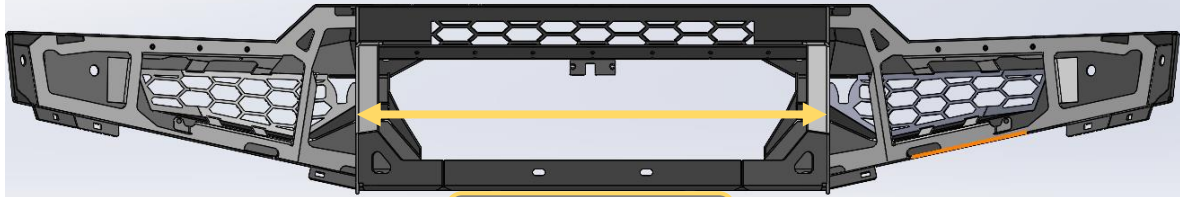

MEASURE



112. Measure Distance between outside edges uprights on bar using tape measure. Write distance below for reference if required.

Bar Upright Width = \_\_\_\_\_mm

113. Adjust mounts by sliding mounts on slots, such that distance between inside edges of mounts is approximately 1-3mm greater than the bar. Check distance is same top and bottom and centered on the vehicle.

114. Snug the 4x main mounting bolts, such that the impact assemblies are sitting flat on the chassis mounting face and re-check. Readjust as required.

**TOOLS REQUIRED**

TAPE MEASURE  
13, 15 & 16mm Spanner / Socket

**FASTENERS**

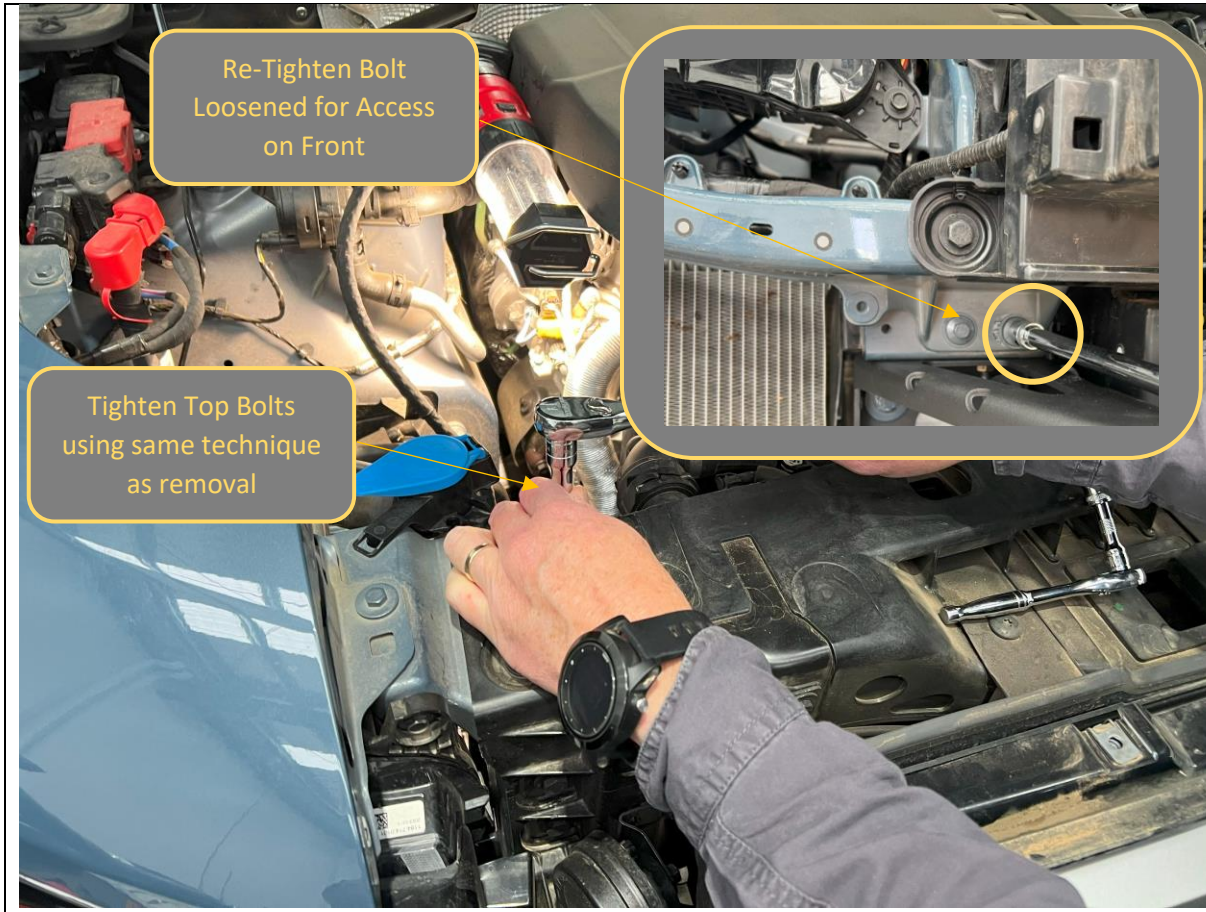

115. Once happy with alignment, with the front face bolts snug, tighten the impact assembly bolts in the following order.

116. First tighten the top bolts, using the same (difficult) access techniques and 3/8" Ratchet /extension bars used to remove them.

117. **IMPORTANT** Re-tighten the bolt on front LHS Front loosened to allow top tool access.

**TOOLS REQUIRED**

3/8" Drive Ratchet  
3/8" Universal Joint  
3/8" Medium Extension Bar  
3/8" Long Extension Bar  
10mm Socket

**FASTENERS**

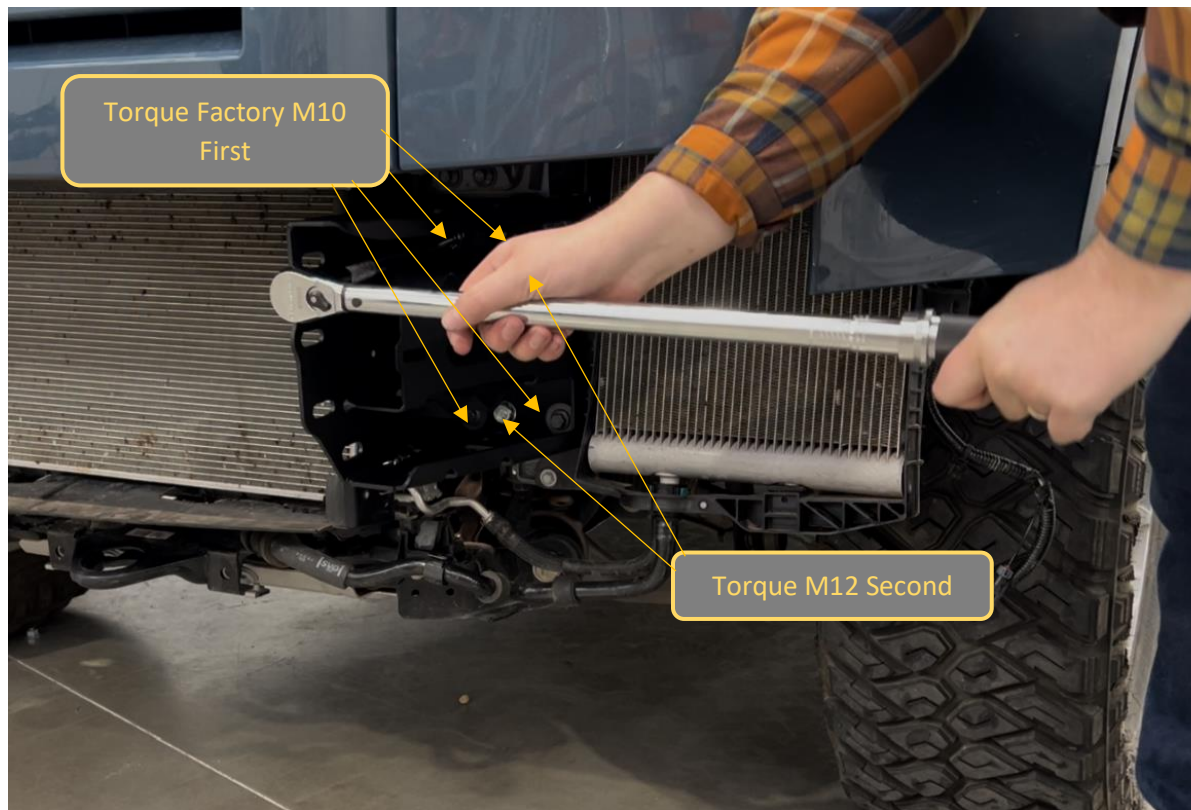

118. Next tighten the Factory M10 Flange bolts using a torque Wrench and extension bar.

**IMPORTANT. THESE BOLTS INTO THE ALUMINIUM CHASSIS END NEED TO BE TIGHTENED TO CORRECT TORQUE – USE A TORQUE WRENCH NOT IMPACT GUN!!!**

119. Torque **M10 to 56 Nm**

120. Finally Tighten the M12 bolts, secured into the nut plates, using a torque wrench and extension bar.

121. Torque **M12 to 99Nm**

122. Complete tightening sequence on both sides.

**TOOLS REQUIRED**

13mm Socket  
18/19mm Socket  
Extension Bar  
Torque Wrench

**FASTENERS**



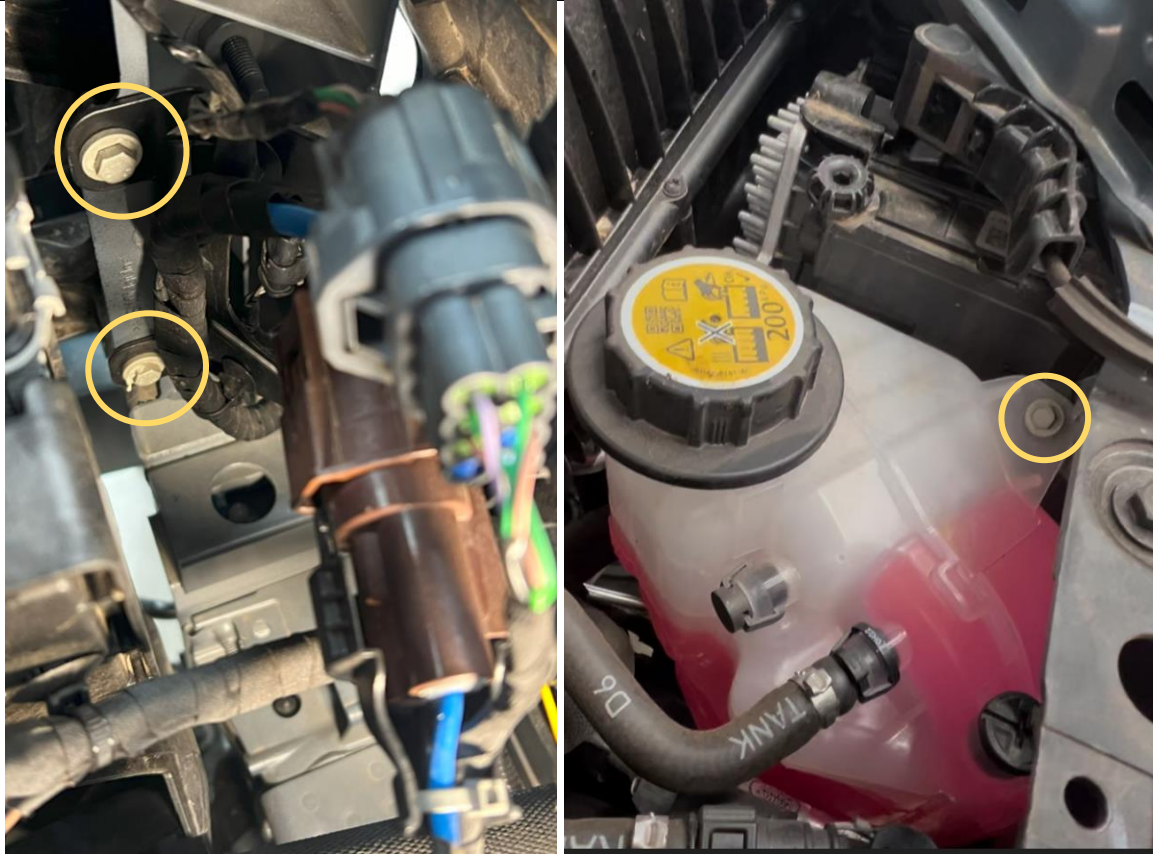

123. Re fix the wiring bracket and coolant overflow tank that were loosened for access to the top impact assembly bolts.

124. Ensure the coolant tank is properly re-seated on the support tabs before replacing bolt

**TOOLS REQUIRED**

10mm socket  
8mm socket

**FASTENERS**

Re-Fit Factory bolts



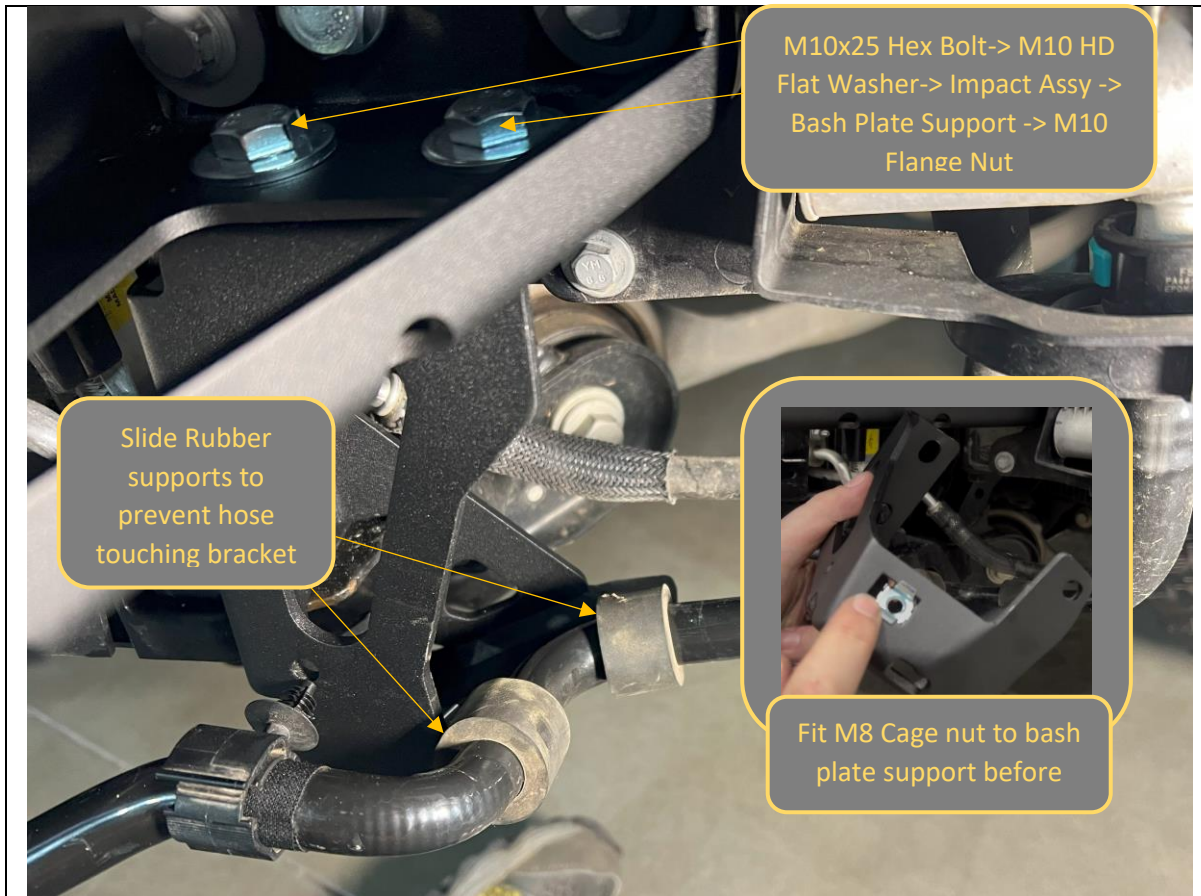

125. Fit M8 Cage nuts to the rectangular slot on the bottom of the bash plate support brackets.
126. Next fit the bash plate support brackets to the slots on the bottom of the impact assembly, using supplied M10x25 Hex bolts, HD flat washers and M10 Flange Nuts
127. Align parallel with the inner edge of the impact assembly, ensure clearance to chassis and tighten in position, using 15&16mm Spanner and Socket
128. Slide the rubber protection sleeves on the coolant hoses into positions where they will prevent the coolant hoses from contacting the bracket.
129. Complete bash plate support fitment for both sides.

**TOOLS REQUIRED**  
16mm Spanner  
15mm Spanner / Socket

**FASTENERS**  
2x M10x25 Hex bolts  
2x M10 HD flat washers  
2xM10 Flange Nuts  
  
Per side

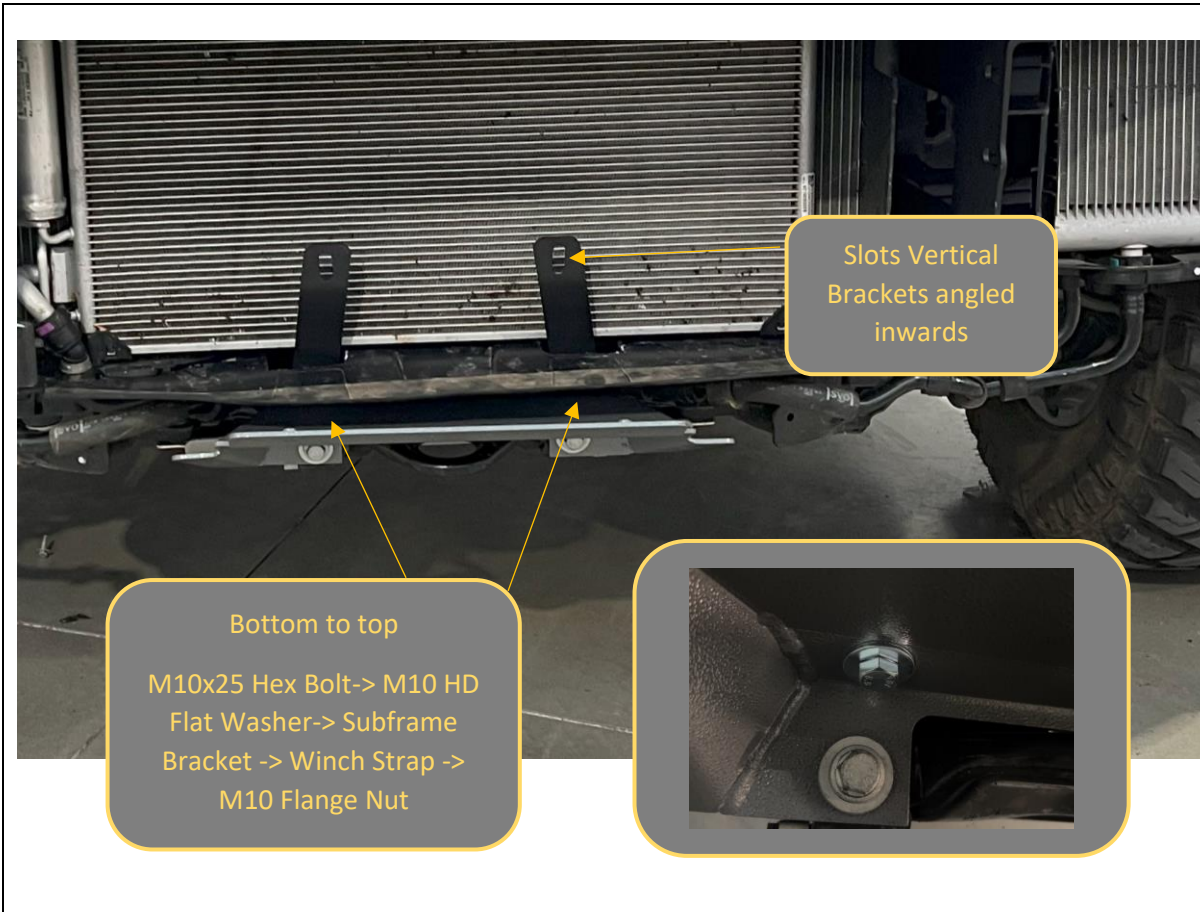

- 130. Fit the Winch support straps to the slots on the top of the subframe bracket, using supplied M10x25 Hex bolts, HD flat washers and M10 Flange Nuts.
- 131. Ensure the straps are on the correct side and in the correct orientation. The slots should be vertical, and sides angled slightly inwards.
- 132. Leave bolts securing straps finger tight at this stage.

**TOOLS REQUIRED**

- FASTENERS**
- 2x M10x25 Hex bolts
  - 2x M10 HD flat washers
  - 2xM10 Flange Nuts

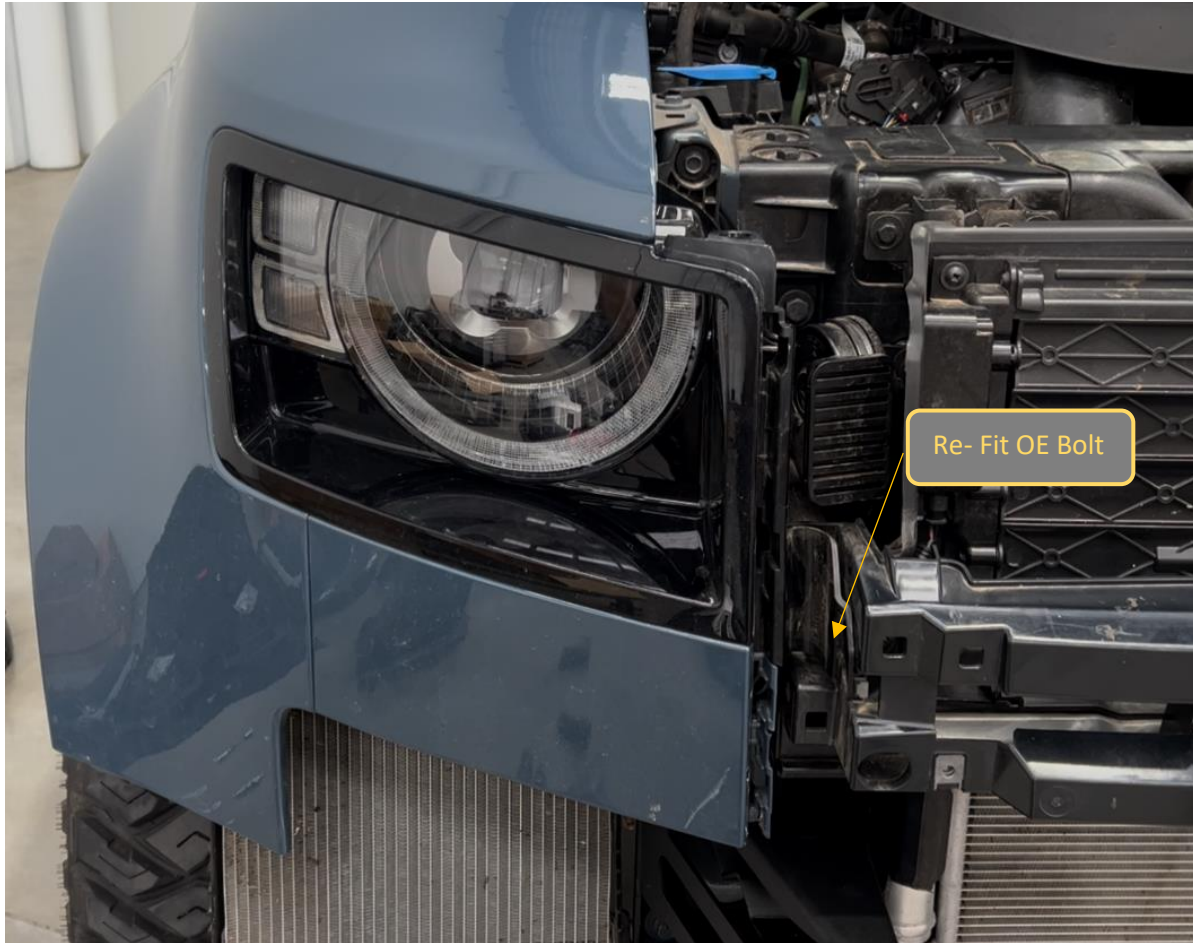

- 133. Re Fit headlight surround trims.
- 134. Push into place from the front to secure clips then replace the original 10mm head factory bolt.
- 135. Complete for both sides

**TOOLS REQUIRED**  
10mm Socket

**FASTENERS**  
10mm Head Factory Bolt



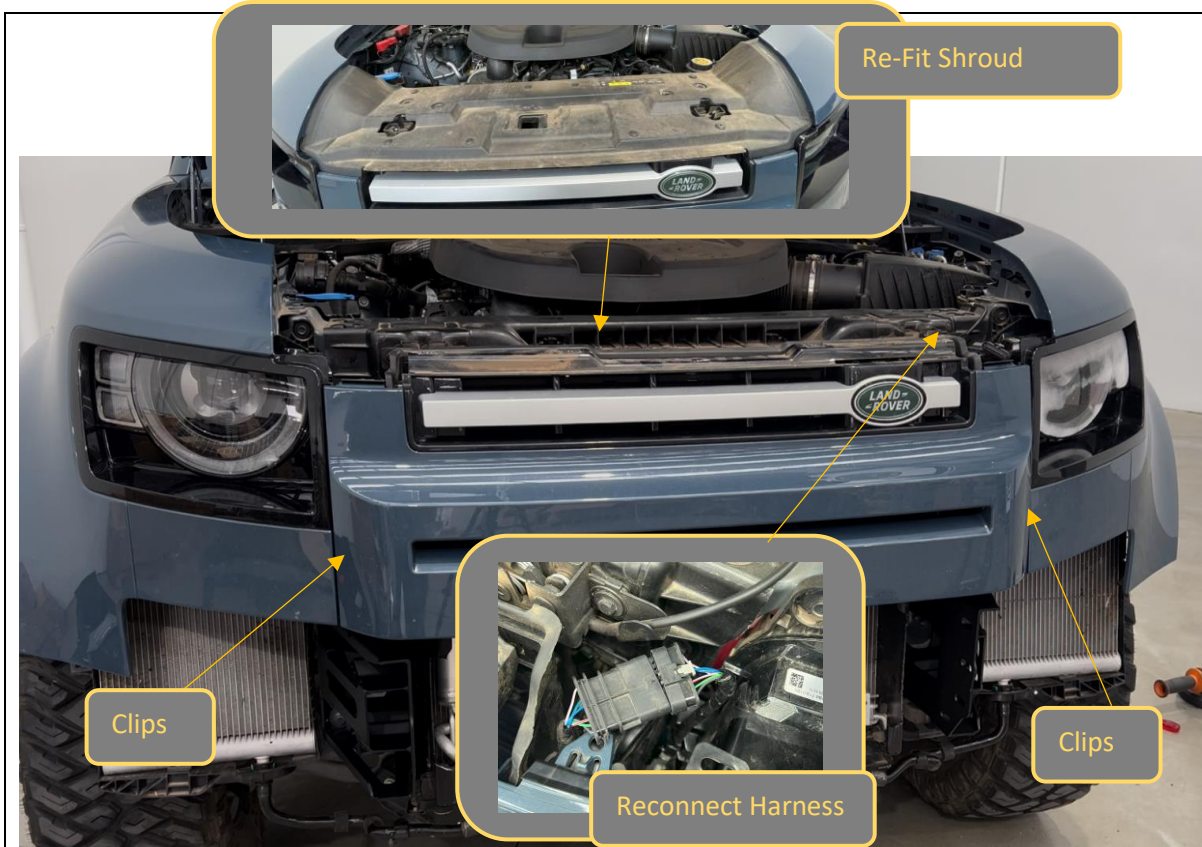

136. Re Fit Grille, push into position to re-seat clips securing down both sides of the grille.







137. Re-connect the Radar wiring harness connector

138. Re-fit the radiator shroud panel, re-using the original Center lift clips and T30 Torx Screws.

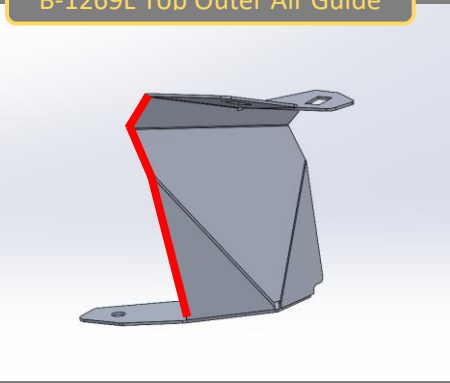
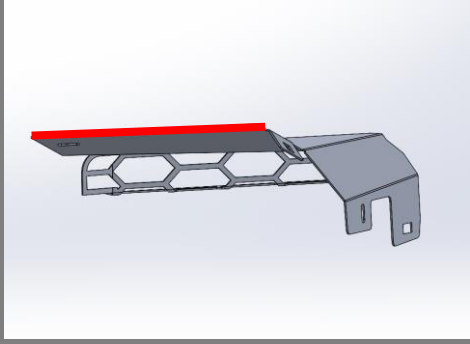
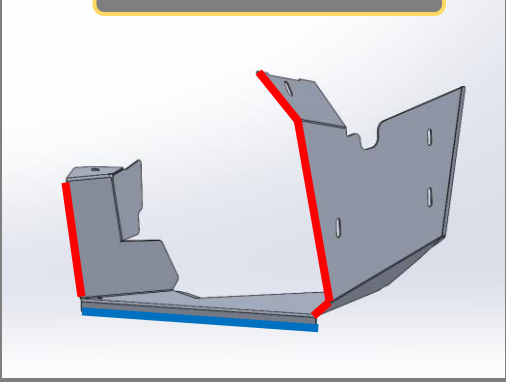
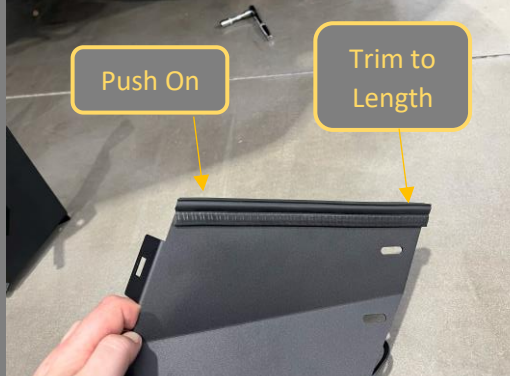
**TOOLS REQUIRED**  
T30 Torx Screwdriver

**FASTENERS**  
Factory Clips  
Factory Torx Screws



<p><b>B-1269L Top Outer Air Guide</b></p> 	<p><b>B-1270L Top Inner Air Guide</b></p> 		
<p><b>B-1271L Lower Air Guide</b></p> 			
<p>139. Unpack and identify the 3x air guide brackets for each side of the vehicle.</p> <p>140. Fit supplied pinch weld to the back edges indicated in the images above, firmly pressing the pinch weld over the edge, then cutting to length with side cutters.</p> <p>141. Note the two different types of pinch weld, denoted by the following code. Ensure correct type used in each location</p> <table border="1" data-bbox="288 1518 826 1682"> <tr> <td style="text-align: center;"> <p><b>RED – Top Bulb</b></p>  </td> <td style="text-align: center;"> <p><b>Blue – Side Bulb</b></p>  </td> </tr> </table> <p>142. Complete pinch weld application for both LH and RH air guide brackets.</p>	<p><b>RED – Top Bulb</b></p> 	<p><b>Blue – Side Bulb</b></p> 	<p><b>TOOLS REQUIRED</b></p> <p>Side Cutters</p> <hr/> <p><b>FASTENERS</b></p> <p>Pinch Weld Rubber</p>
<p><b>RED – Top Bulb</b></p> 	<p><b>Blue – Side Bulb</b></p> 		

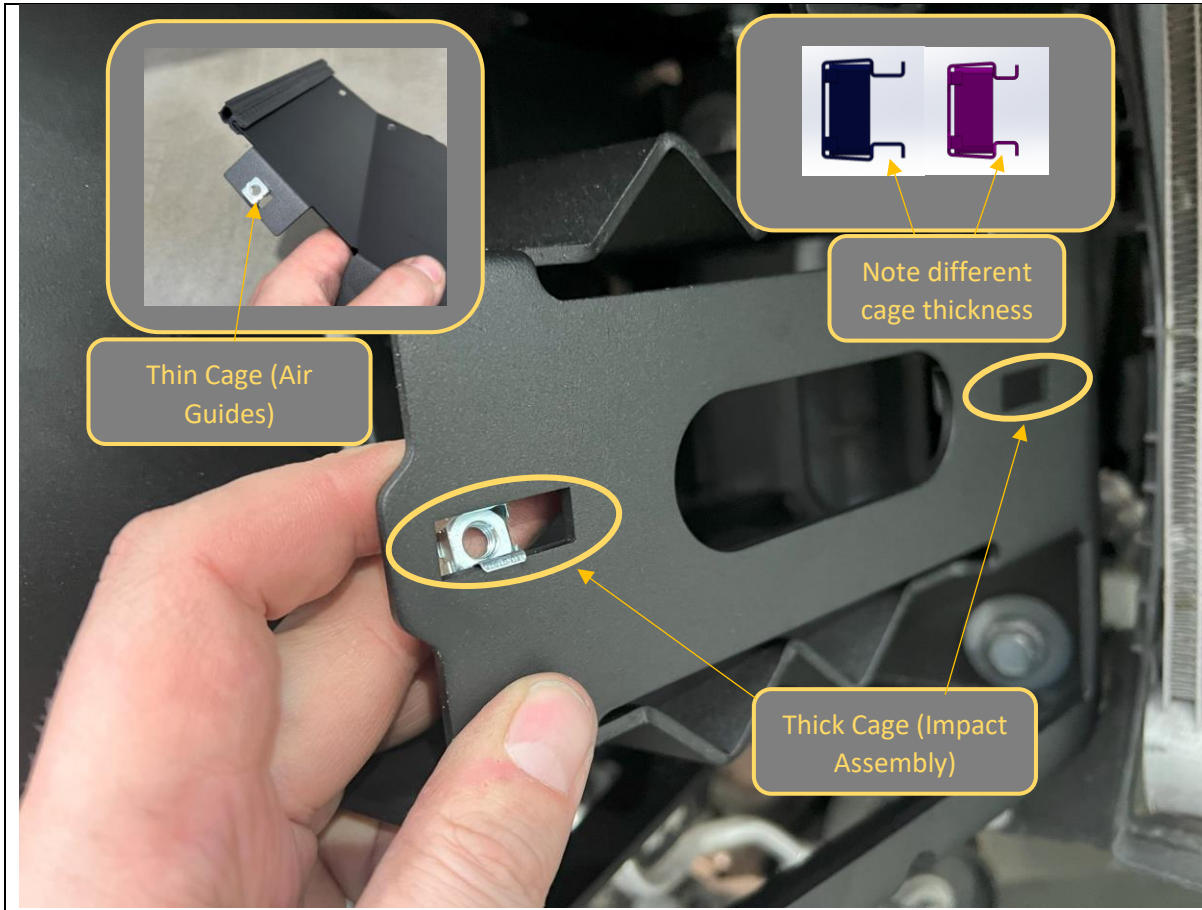

- 143. Fit M6x3mm cage (thicker cage) nuts to the 2x rectangular slots in the impact assembly. Place nut behind slot and squeeze into position. A flat bladed screwdriver can be used to assist.
- 144. Fit M6x2mm cage (thicker cage) nuts to the 4x (2 per bracket) rectangular slots in the upper air guide brackets.
- 145. Repeat for both LH and RH air guide brackets.

**TOOLS REQUIRED**

Flat Screwdriver

**FASTENERS**

2x M6x3mm Cage Nut  
2x M6x2mm cage nut

Per side

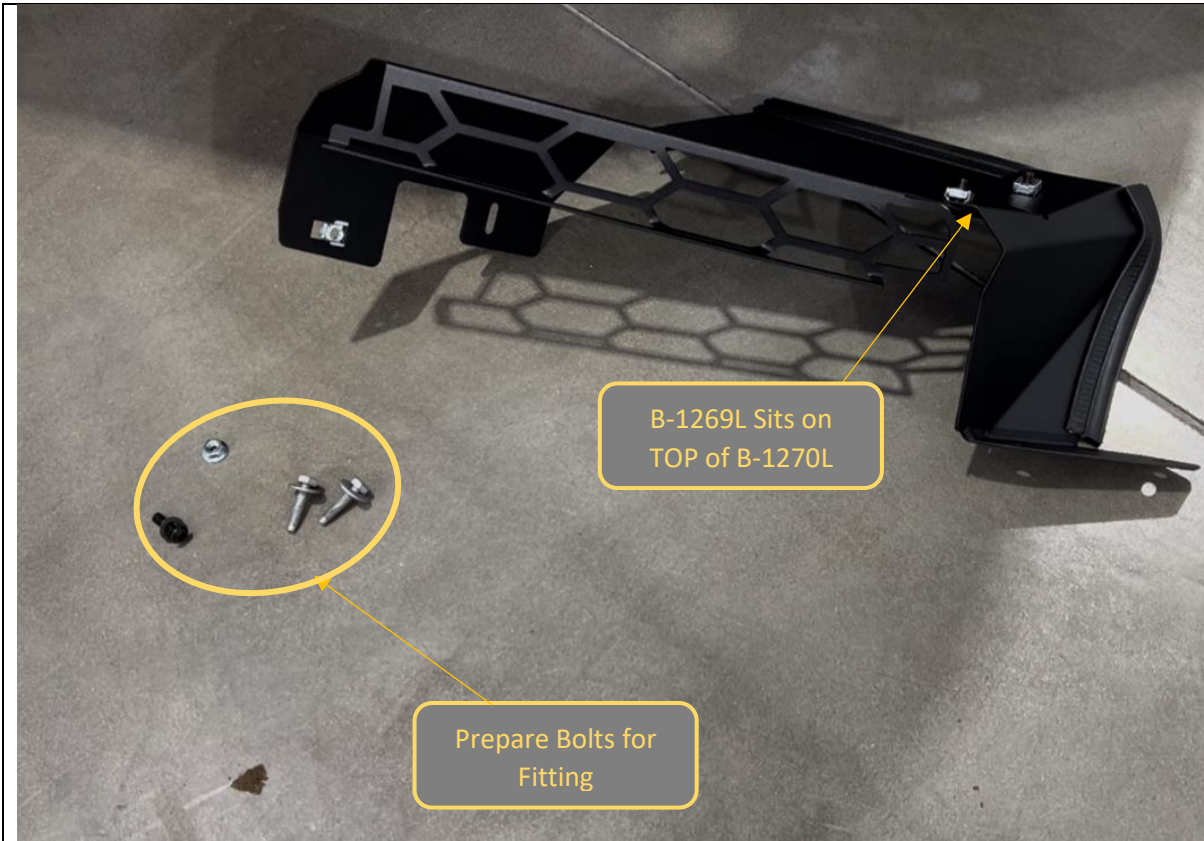

- 146. Pre-Assemble upper air guide, using M6x20 Black Button head screws and Cage nuts into the cage nuts placed in last step. Leave bolts loose at this stage.
- 147. Ensure the outer guide sits ON TOP of the inner guide.
- 148. Repeat for both LH and RH air guide brackets.
- 149. Gather the required bolts for fitting so they are at hand. 2x 10mm head Factory Bolts (from bumper clip removal) and 1x M6x20 BH screw, Flat washer and Flange Nut are required.

**TOOLS REQUIRED**

**FASTENERS**

2x M6x20mm Black Button Head Bolt  
2x M6 Black Flat washer

Per side



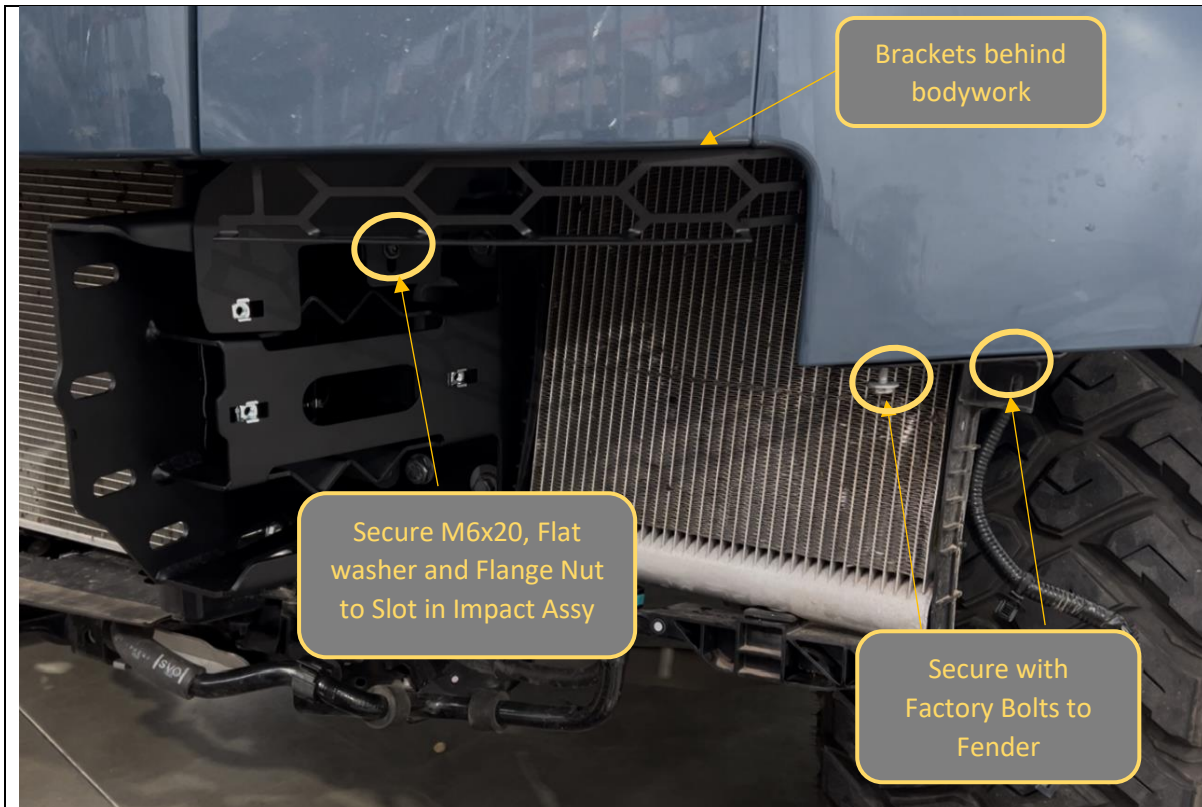

<p>150. Fit the pre-assembled upper air guide to the vehicle. Secure to the fender using the factory bolts, and to the slot in the impact assembly using the M6x20 BH screw, Flat washer and Flange Nut are required.</p>	<p><b>TOOLS REQUIRED</b> 10mm Socket 4mm Hex Key</p>
<p>151. Manipulate the position of the guides such that they sit level and behind the bodywork. The back edge of the rubber pinch weld should be in contact with the radiator / radiator supports.</p> <p>152. Once happy with position tighten bolts, first ones securing to vehicle, then ones securing the two pieces of air guide together.</p> <p>153. Repeat for both LH and RH air guide brackets.</p>	<p><b>FASTENERS</b> 2x 10mm head Factory Bolts (from bumper clip removal) 1x M6x20 BH screw 1x M6Flat washer 1x M6 Flange Nut</p> <p>Per Side</p>

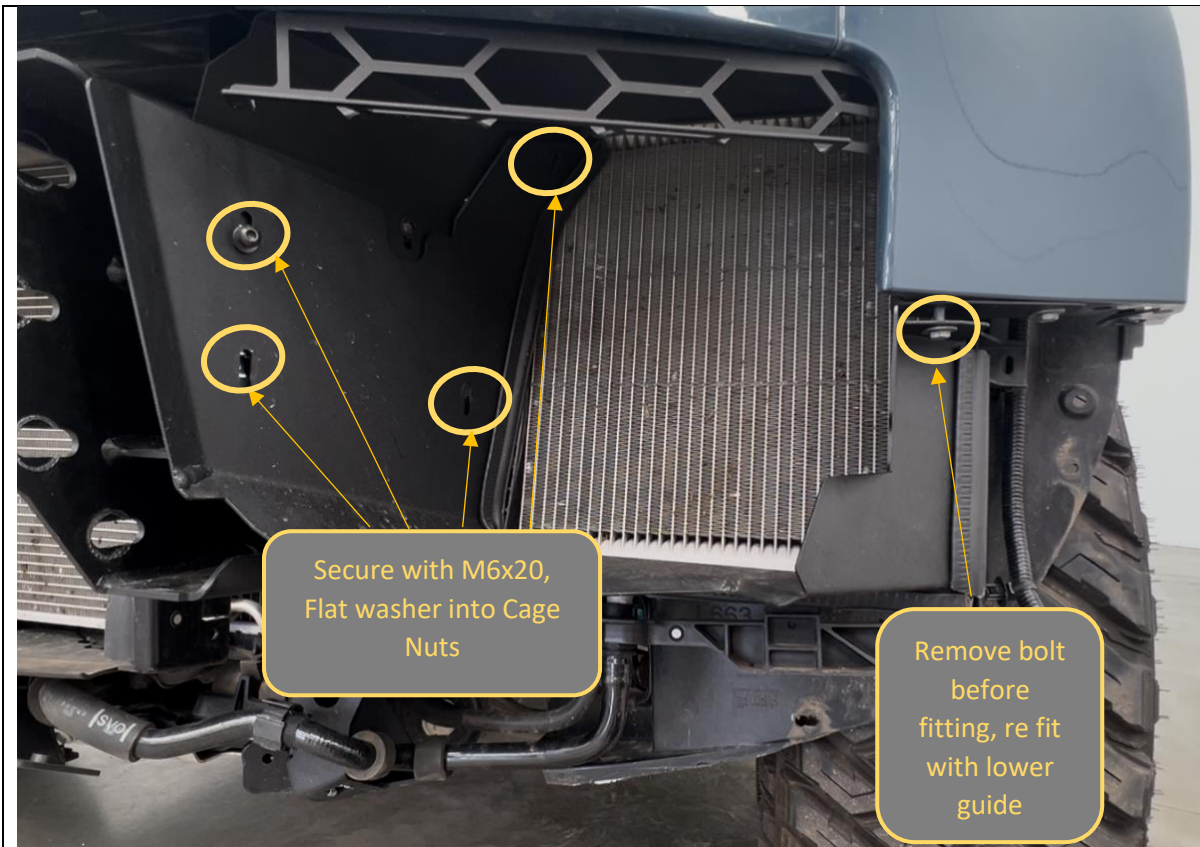

<p>154. Remove the inner most factory bolt from the fender again.</p> <p>155. Fit the lower air guide to the fender, impact assemblies and upper air guide brackets. Secure with bolts as shown in image above</p> <p>156. Manipulate the position of the guides such that they sit level. The back edge of the rubber pinch weld should be in contact with the radiator / radiator supports.</p> <p>157. Once happy with position tighten bolts, first ones securing to vehicle, then ones securing the air guides together.</p> <p>158. Repeat for both LH and RH air guide brackets.</p>	<p><b>TOOLS REQUIRED</b> 10mm Socket 4mm Hex Key</p>
	<p><b>FASTENERS</b> 4x M6x20 BH screw 4x M6Flat washer</p> <p>Per Side</p>

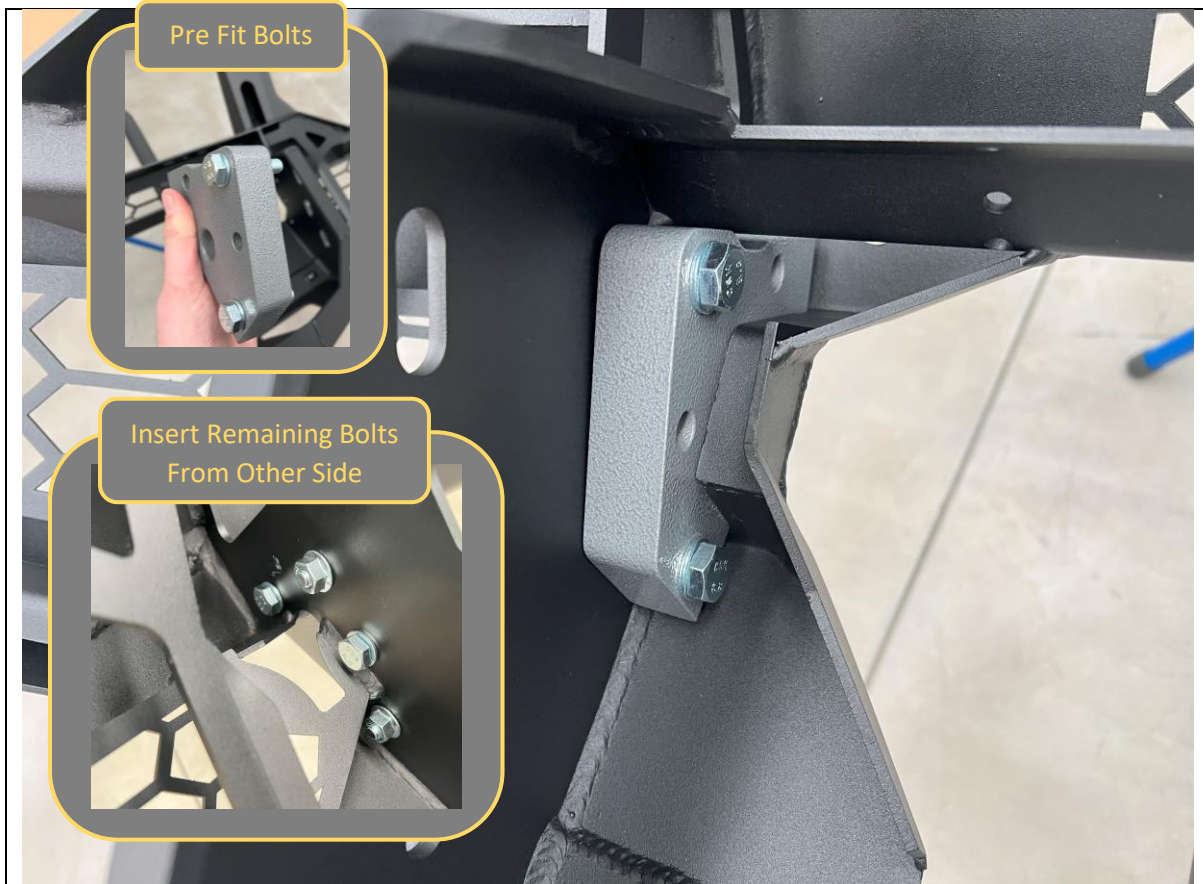

<p>159. Prepare bar for fitment. Start Fitting the Auxiliary tow points to the bar.</p> <p>160. Pre Fit 2x M10X45mm bolts + M10 Flat washers to the tow point as shown in inset image.</p> <p>161. Fit the Auxiliary tow points to the bar, sliding part into position from behind. Secure with 2x M10 Flange Nuts</p>	<p><b>TOOLS REQUIRED</b></p> <p><b>15,16/17mm Spanner</b></p>
<p>162. Insert 2x Remaining M10x45 Bolts from other side of upright, Secure with M10 Flange Nuts.</p> <p>163. Tighten with 15 &amp; 16/17mm Spanners.</p> <p>164. Repeat for both sides of bar.</p>	<p><b>FASTENERS</b></p> <p>4x M10x45 Hex 4x M10 Flat Washer 4x M10 Flange Nut</p>





165. Route the Wiring harness through the bar such that all plugs are in the correct location. The main harness connector should sit to the OUTSIDE of the mid wing brace on the LH side of the vehicle as shown in the image above.

166. The wiring loom should be routed through the passage above the wing mesh cutout.

167. It is easier to disconnect the parking sensors from the loom for this step. Slide back the red tab and press down on connector to release. Take note of correct positions of sensors for re-fitment.

**TOOLS REQUIRED**

**FASTENERS**

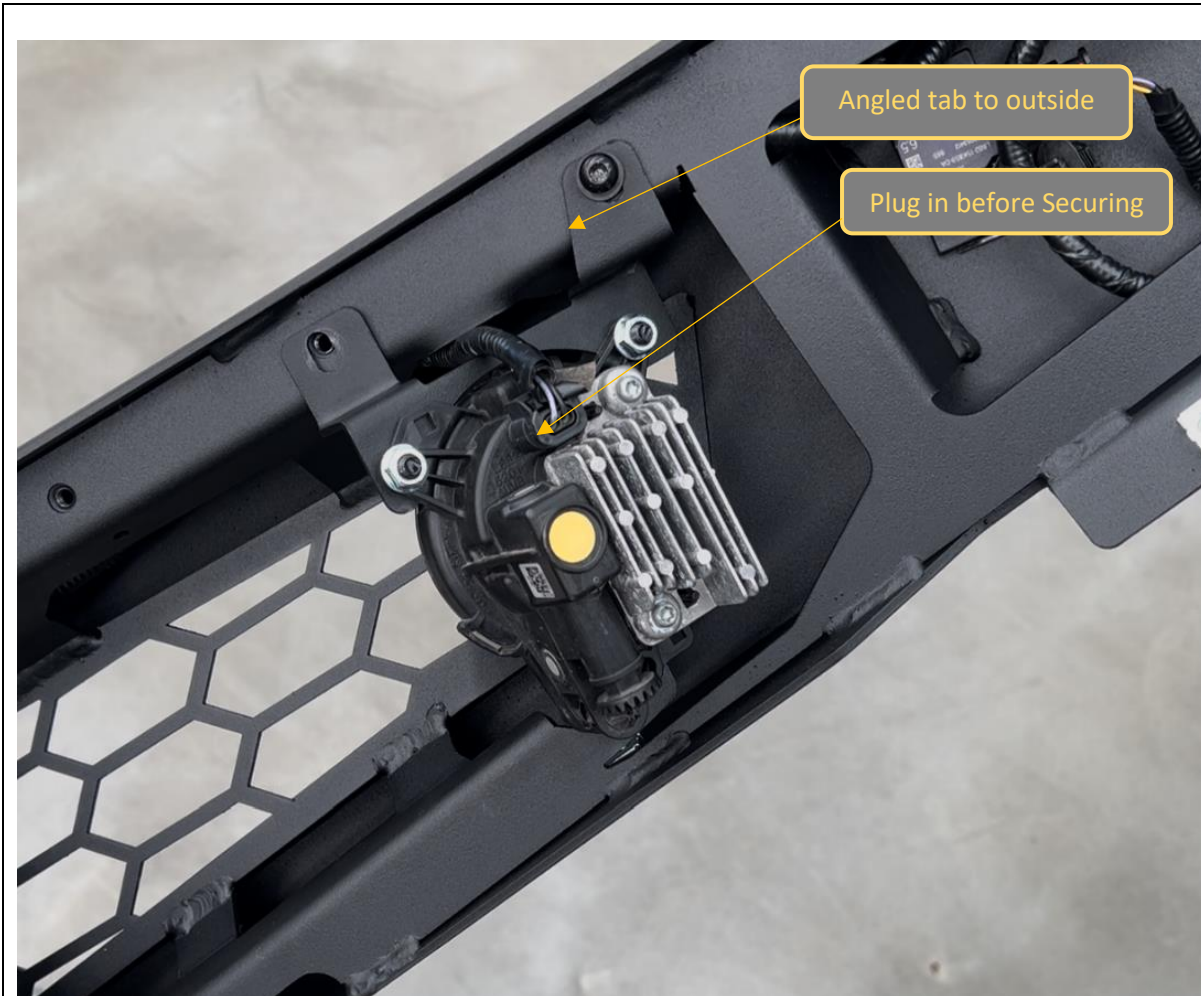

168. Fit the fog lights to the fog light brackets using supplied M6x16 black button head bolts and flange nuts. Fog lights fit behind the bracket.
169. Fog lights are the same LH and RH. Ensure correct orientation of the brackets by refereeing to the angled tab, which should be on the outside. Fog lights should face forwards when mounted in the bar.
170. Reconnect the fog light harness before securing bracket to bar. The tail is short and is easier to do before bolting down.
171. Fit Fog light brackets to the bar using M6X16 Button head Bolts, Flat washers, and Flange nuts from the Small Parts Kit.
172. Secure and tighten using 4mm Allen Key and 10mm Spanner

**TOOLS REQUIRED**

4mm Allen Key  
**10mm Spanner / Socket**

**FASTENERS**

5x M6x16 BHCS – Black  
5x M6 Flat Washer  
5x M6 Flange Nut  
Per Side

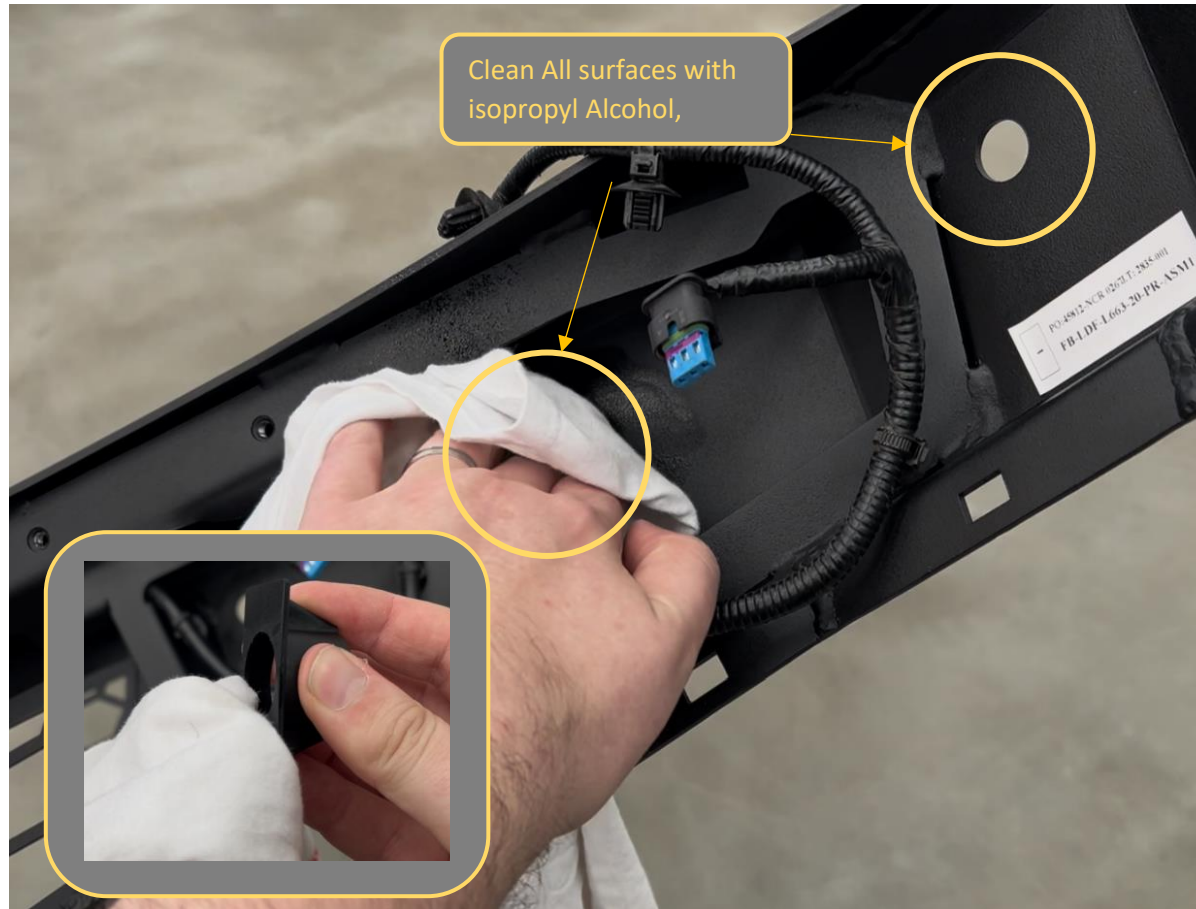

173. Clean area on back side of bar adjacent to sensor holes with isopropyl alcohol.

174. Clean area on Front of parking sensor housings with isopropyl alcohol.

175. Clean for all 6 sensor locations

**TOOLS REQUIRED**

Isopropyl Alcohol,  
Rag

**FASTENERS**



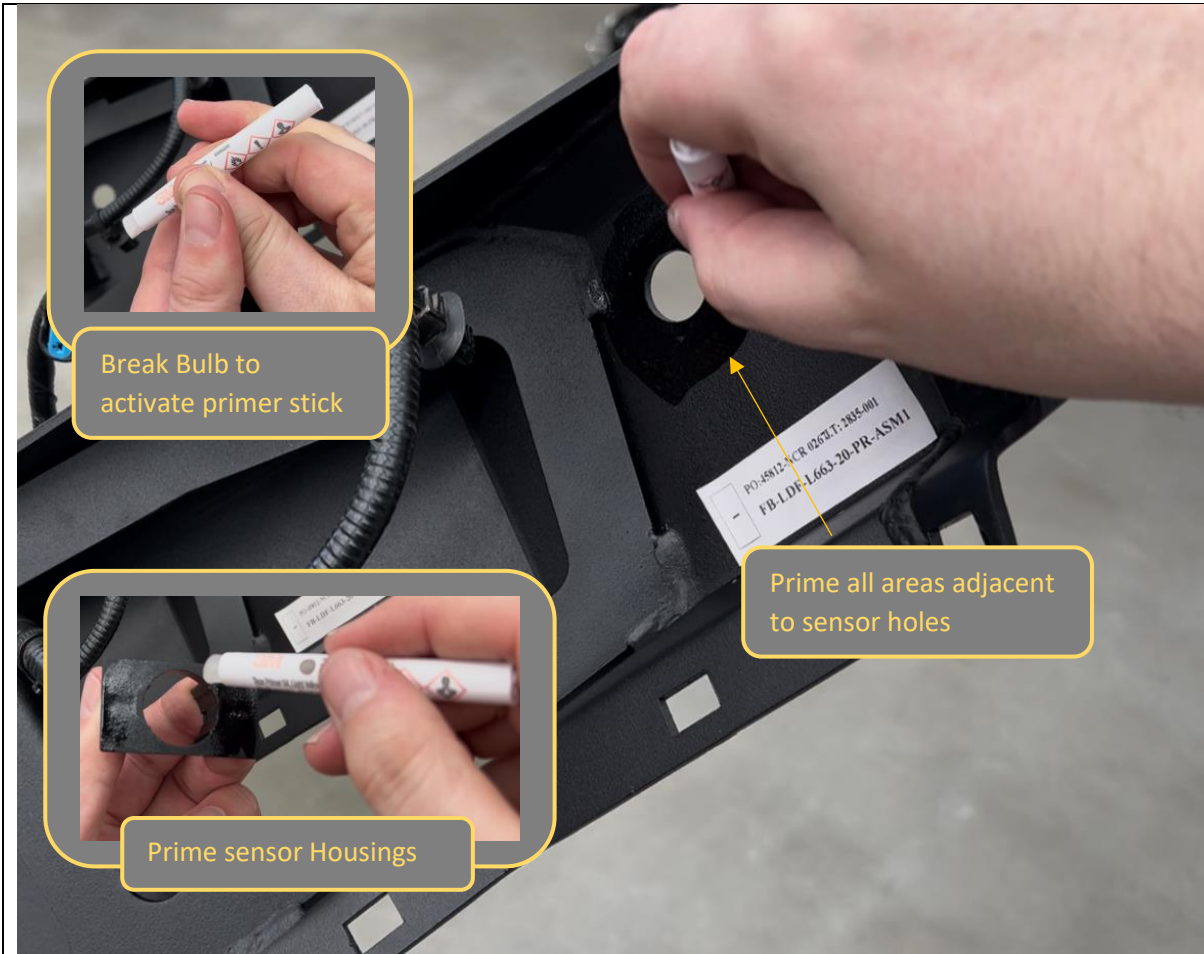

176. Break the bulb of the supplied Primer 94 ampule to activate the primer dispensing.

177. Apply Primer 94 to all areas adjacent to the parking sensor locations, on both the bar and the sensor housings.

178. Primer needs at least 5 minutes to cure before applying tape.

**TOOLS REQUIRED**

**FASTENERS**

Primer 94 Ampule



179. Whilst waiting for the adhesion promoter to cure fit 5x Cage nuts from small parts kit to rectangular slots in bottom of wing.

Use a small flat bladed screwdriver to push the edge of the cage to engage with the slot to aid fitting.

180. Repeat for other side of Bar

**TOOLS REQUIRED**

Small Flat Bladed Screwdriver

**FASTENERS**

5x M6 Cage Nut  
Per side

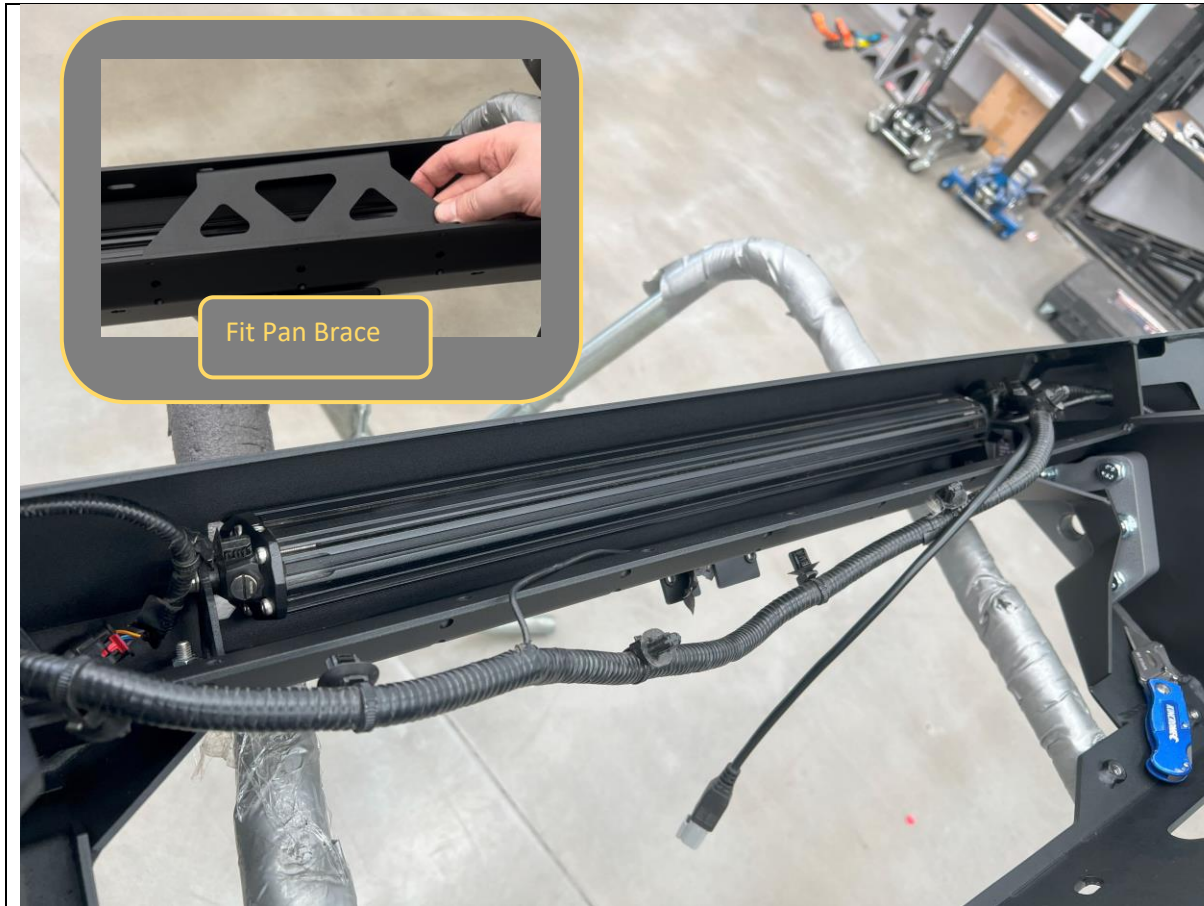

<p>181. If fitting an integrated light bar, do so now.</p> <p>182. The bar is designed to fit an Offroad Animal 22in light bar. If fitting this light bar, assemble bar with legs out, and it will line up with the slots in the center gusset. Secure with M6 Fasteners supplied with the light bar.</p>	<p><b>TOOLS REQUIRED</b></p> <p>10mm Spanner / Socket 5mm Hex Key</p>
<p>183. The bar can accommodate most other “20- 22inch” size light bars.</p> <p>184. If fitting driving lights, top hoop or Stealth Hoop to the bar this is also the most convenient time to do so. It is still possible later but is much more difficult.</p> <p>185. Fit the pan brace, between the gusset and underside of the top face of bar, using supplied M6X16 button head bolts, Flat washers and M6 Flange Nuts.</p>	<p><b>FASTENERS</b></p> <p><b>Light Bar</b> Supplied with Light Bar</p> <p><b>Pan Brace</b> 5xM6X16 Black button head bolts 5xM6 Black Flat washers 5xM6 Flange Nuts</p>





Fit Tape to housings

Fit Sensors to housing

<p>186. After waiting at least 5 minutes for the primer to cure, Fit supplied VHB tape pads to all sensor housings as shown in the inset photo.</p> <p>187. Fit parking sensors to the sensor housings. Push on sensors to ensure they are fully seated and both sides click into position.</p>	<p><b>TOOLS REQUIRED</b></p>
<p>188. Re-connect sensors to wiring loom.</p> <p>189. Dry fit sensors to bar to check loom position will work.</p> <p>190. Remove backing and adhere sensors in position in bar. Apply pressure for 10-30sec after positioning for best adhesion.</p>	<p><b>FASTENERS</b> VHB Tape pads</p>



191. Ensure the camera loom is correctly routed through the cut out in the gusset.
192. Taking note of the correct orientation, carefully reconnect the camera wiring connector. Ensure the plug is perfectly straight to avoid damaging the delicate center pin.
193. Fit the camera support bracket to the bar, the camera should be supported between the bracket and the flange on the bar. Use supplied M5 Black button head bolts and Black M5 Flat Washers.
194. Tighten with 3mm Hex Key
195. Once complete, tidy up and cable tie looms on bar.

**TOOLS REQUIRED**

3mm Hex Key

**FASTENERS**

2x M5 Black Button head bolt  
2x M5 Black Flat Washer  
Cable Ties



196. With assistance, either from another person, or a lifting trolley, lift the bar onto the mounts on the vehicle.

197. Secure with 4x M12x30 Bolts, Heavy Duty washers and M12 Flange Nuts per side, Finger tight at this stage.

**TOOLS REQUIRED**

Lifting Trolley

**FASTENERS**

8x M12x30 Bolt  
10x M12 Heavy Duty Large Washer  
8x M12 Flange Nut



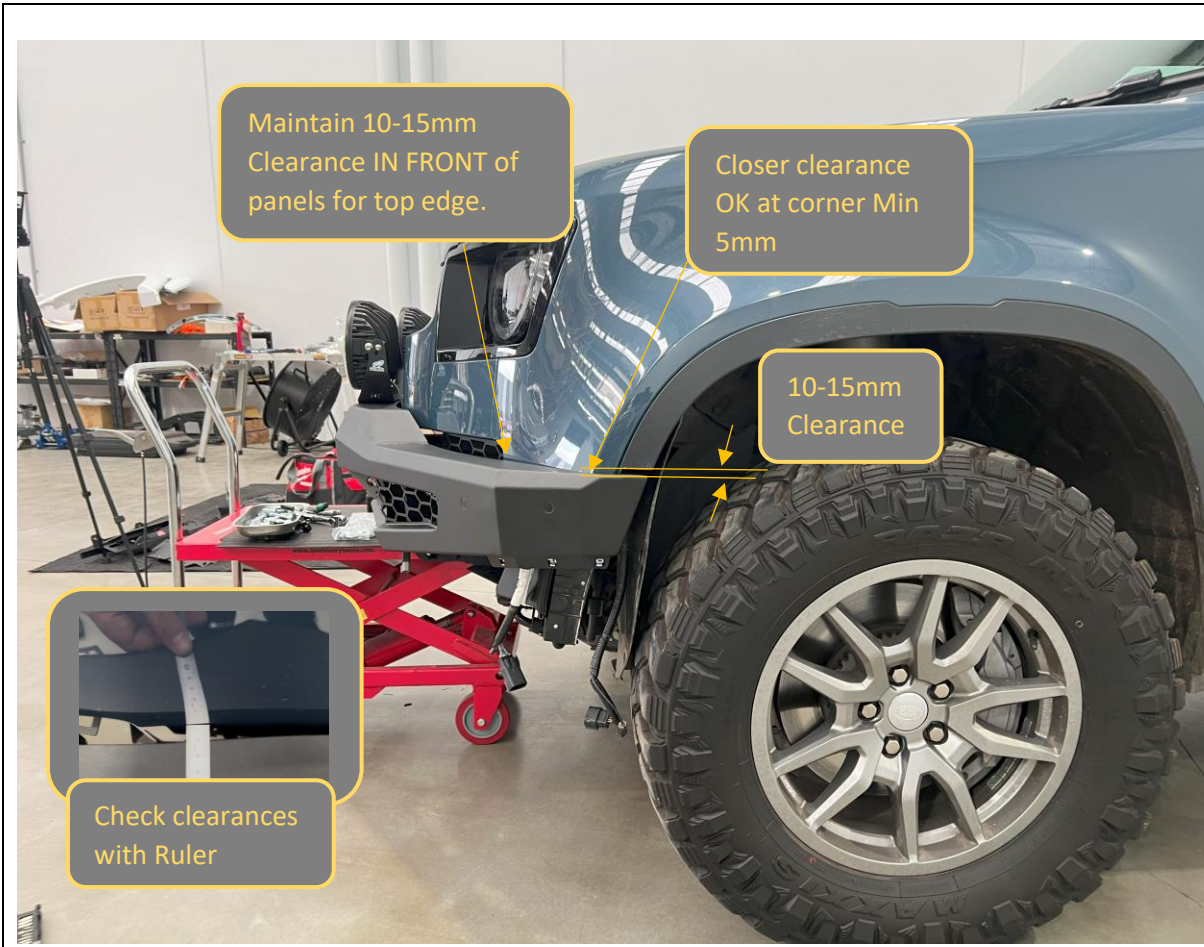

198. With assistance from another person, Align the bar with the edges of the vehicle. Adjust such that the clearances are neat and even side to side.

Acceptable range of clearances shown in image above.

199. Once in position tighten the M12 Bolts using socket and spanner. An impact driver may be used to speed up this process.

**TOOLS REQUIRED**

Lifting Trolley  
18/19mm Socket and Spanner  
Ruler

**FASTENERS**



200. Once bar is secured in position, Secure the winch support straps to the back side of the winch cradle, using M10x25 Hex Bolts, HD Flat washers and M10 Flange Nuts.

201. Tighten M10 Bolts at both ends of the winch straps.

**TOOLS REQUIRED**

16/17mm Socket

**FASTENERS**

2xM10x25 Bolt  
2xM10 HD washer  
2x M10 Flange Nut



202. Reconnect the main wiring harness and camera connector. Take care to align and connect the mini co-axial connector for the camera carefully as it is very easy to bend the center pin.

203. Start the car and confirm the correct operation of the front camera, parking sensor and fog lights.

**TOOLS REQUIRED**

16/17mm Socket

**FASTENERS**

2xM10x25 Bolt  
2xM10 HD washer  
2x M10 Flange Nut





204. If fitting a winch, do so now.

205. The bar is designed to fit most low mount winches, in foot down configuration. WARN ZEON 12 is largest winch confirmed to fit.

206. The control box can be mounted on top of the winch. Winches usually come with a bracket to allow this. Refer to winch manufacturer.

207. Ensure clutch handle will be accessible through access hole in front mesh panel. Refer to winch instructions regarding changing clutch handle location.

**TOOLS REQUIRED**

Refer to winch fitting instructions

**FASTENERS**

Supplied with winch

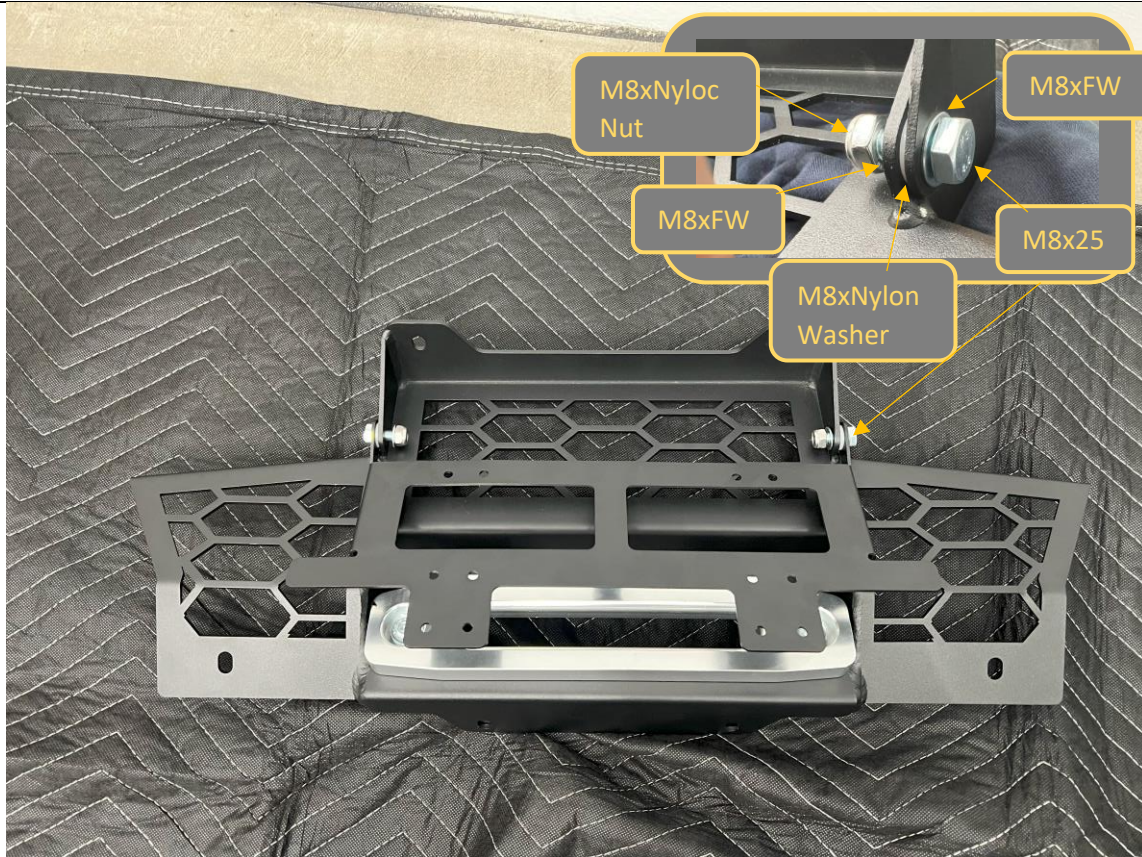

208. If Required, Fit winch fairlead to Mesh Panel. Use M10 or 3/8" Fasteners supplied with winch. The bar is only compatible with low profile Hawse type fairleads.

209. Fit Number plate flip bracket to fairlead mount, M8x20 Bolt, Flat washer, Nylon washer and Nylon Lock nut. Ensure nylon washer sits between the bracket and fairlead mount.

**TOOLS REQUIRED**

13mm Spanner  
10mm Spanner  
4mm Hex Key

**FASTENERS**

2x M8x20 Hex Head  
2x M8 Nyloc Nut  
2x M8 Nylon Washer  
4xM8 Flat Washer

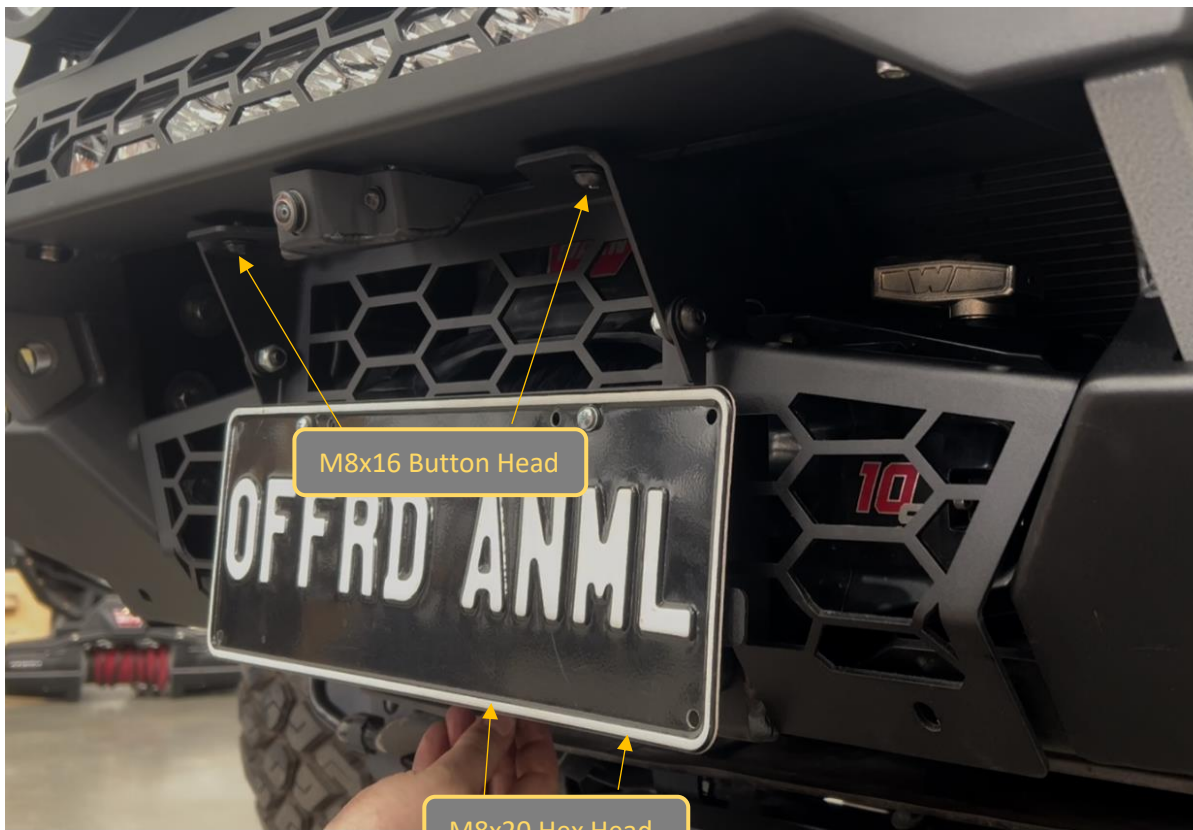

<p>210. Fit the Mesh Fairlead Mount to the center of the bar, using M8x16 Button head (Top), M8x20 Hex (Bottom) M8 Flat washers</p> <p>211. Tighten fasteners using 13mm socket / spanner and 5mm Allen Wrench.</p>	<p><b>TOOLS REQUIRED</b></p> <p>13mm Spanner 5mm hex key</p>
	<p><b>FASTENERS</b></p> <p>2x M8x16 Button Head 2x M8x20 Hex Head 4xM8 Flat Washer</p>



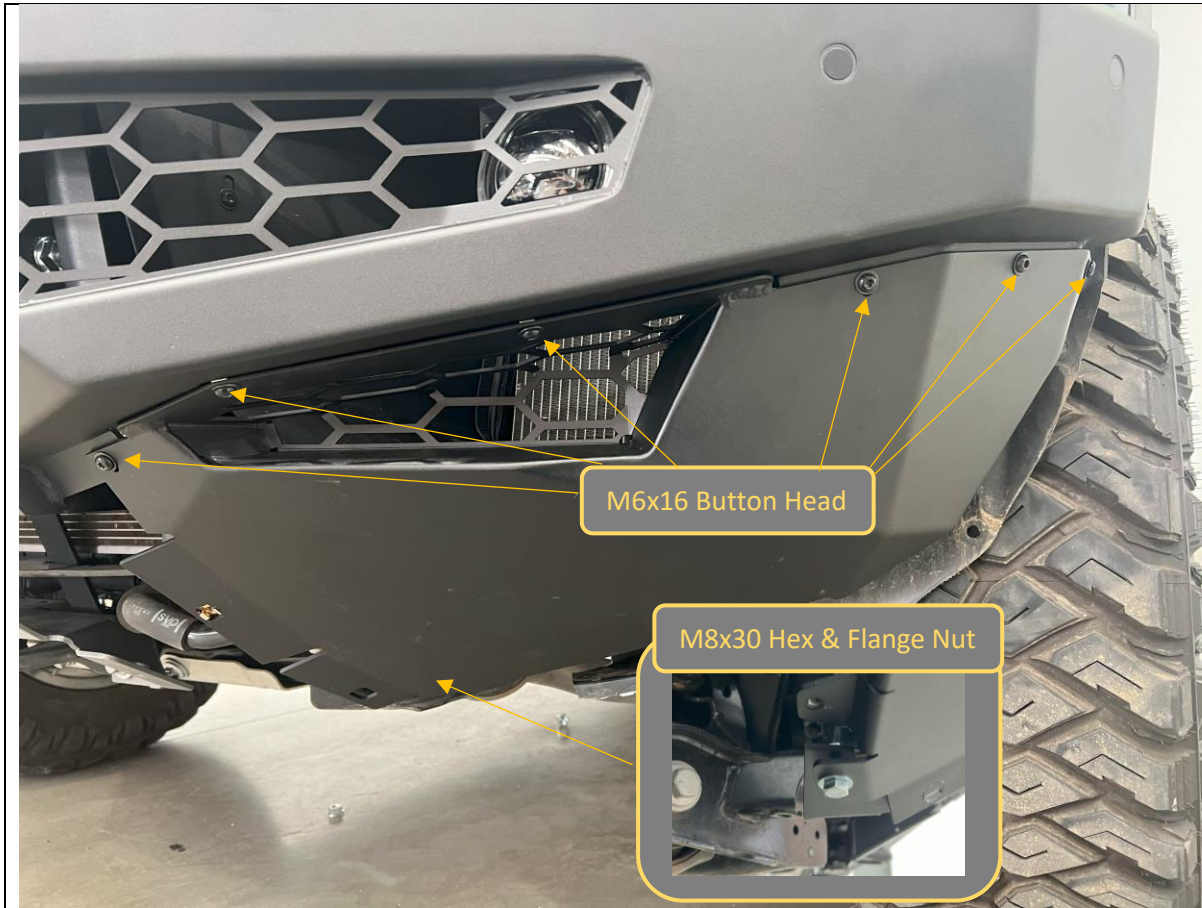

212. Before fitting the side under panels, insert the M6 Cage nut into the upper rectangular slot on the inside edge.

213. Fit the side under panel to the cage nuts in the bar using Black M6x16 Button head bolts and M6 Flat Washer

214. Fit the bottom corner of the side under panel to the bash plate support bracket with M8x30 Bolt, Flat washer and M8 Flange Nut.

215. Push panel up as far as possible on slots, then tighten M6's starting with vertical bolts, then the horizontal bolts.

216. Tighten the M8 Bolt in the bottom corner.

217. Complete under panel fitment on both sides of the vehicle.

**TOOLS REQUIRED**

4mm Hex Key  
13mm Socket / Spanner

**FASTENERS**

5x M6x16 Black Button Head  
5x M6 Black Flat Washer  
1xM8x30 Hex  
1xM8 Flat Washer  
1x M8 Flange Nut

Per side



218. Screw in 4xM6x16 Button head bolts into the threaded inserts in the back of the side under panels. Leave Finger tight.

219. Cover each of the bolt locations with masking tape

**TOOLS REQUIRED**

Masking Tape

**FASTENERS**

4x M6x16 Black Button Head

Per side

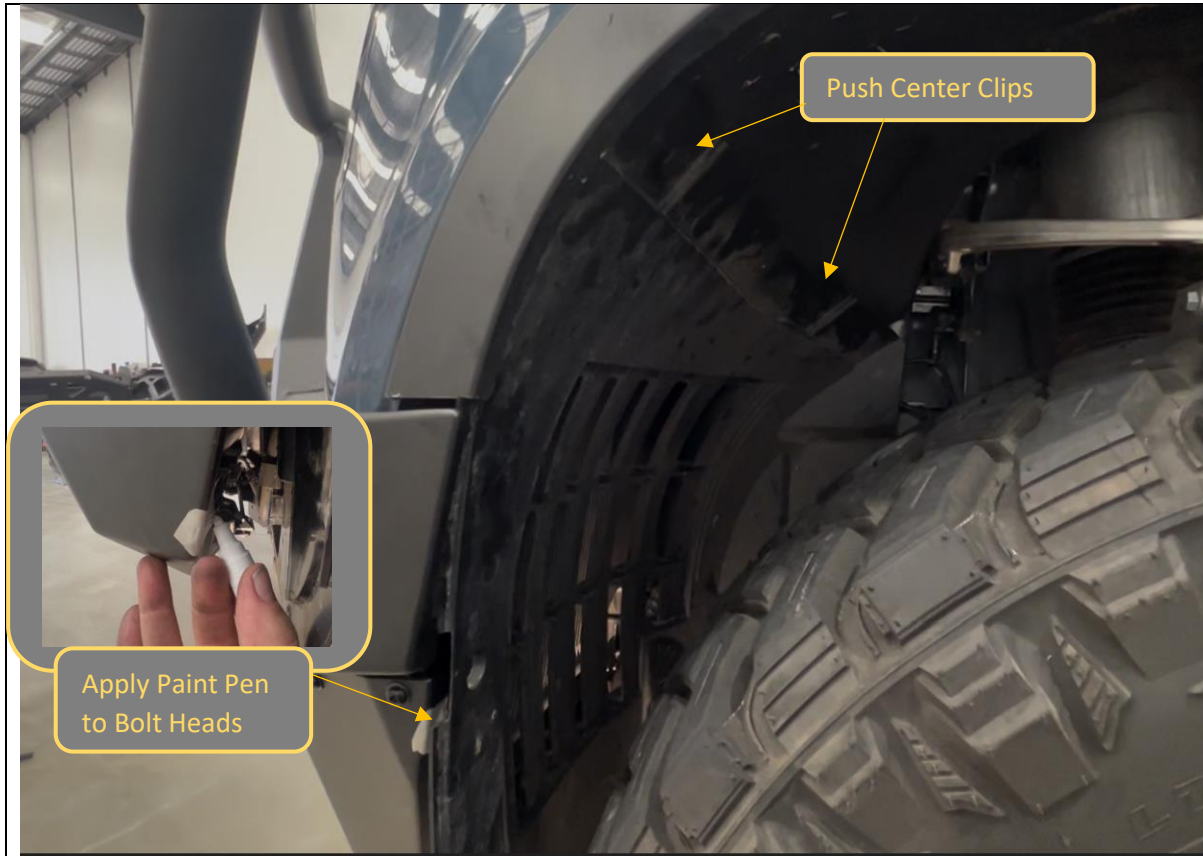

220. Re fit the inner wheel arch liner, using the 2x push center clips.

221. Peel back the wheel arch liner and apply paint marker to the protruding tips of all 4x bolts in the side under panel/

**TOOLS REQUIRED**  
Paint Marker

**FASTENERS**

Push center clips (re-use)





222. Carefully flex the inner wheel arch liner forward to conform with the edge of the under panel. With assistance complete the following steps whilst holding in this position.

223. Apply pressure at all bolt locations to transfer paint from bolt heads onto wheel arch liner.

224. Mark the intersection of the under panel with a paint pen or marker.

225. Release then remove the inner arch liner.

**TOOLS REQUIRED**

Paint Marker

**FASTENERS**

Push center clips (re-use)

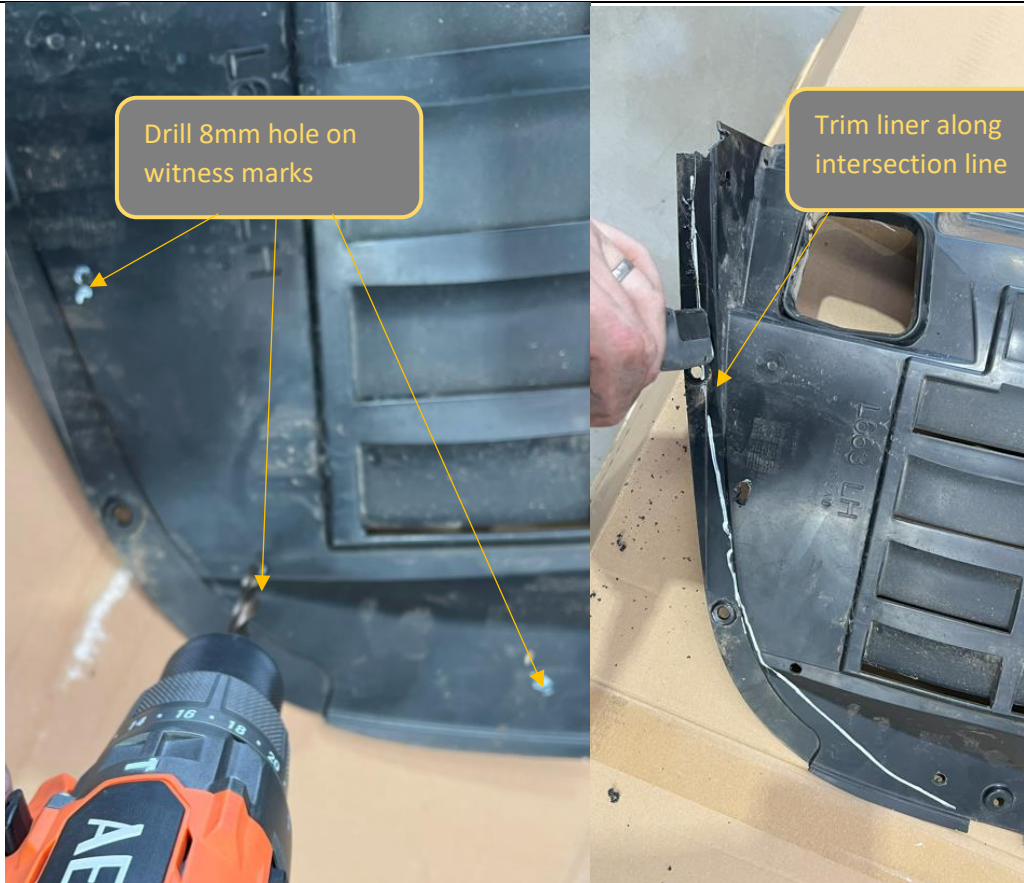

- 226. Drill 8mm holes at the witness mark locations for the bolt heads.
- 227. Using air hacksaw or oscillating multi tool, Trim just inside intersection line mark.
- 228. Mark the intersection of the under panel with a paint pen or marker.
- 229. Re-Fit arch liner to car, secure with Push center clips at top, and using 4x M6x16 Bolts, HD flat washers into the threads on the side under panels.
- 230. Complete all arch liner trims for both sides of the vehicle.

**TOOLS REQUIRED**

- Electric Drill
- 8mm Drill bit
- Air hacksaw  
or  
Oscillating multi tool

**FASTENERS**

- 5x M6x16 Black Button Head
- 5x M6 Black Flat Washer
- 1xM8x30 Hex
- 1xM8 Flat Washer
- 1x M8 Flange Nut

Per side



231. Fit the Compliance Plate to the underside of the winch cradle. Remove the backing paper and secure with the pre applied adhesive. Apply pressure for 10-20 Seconds for a good bond.

232. This location allows the compliance plate to be visible through the bash plate ventilation cutouts.

**TOOLS REQUIRED**

**FASTENERS**



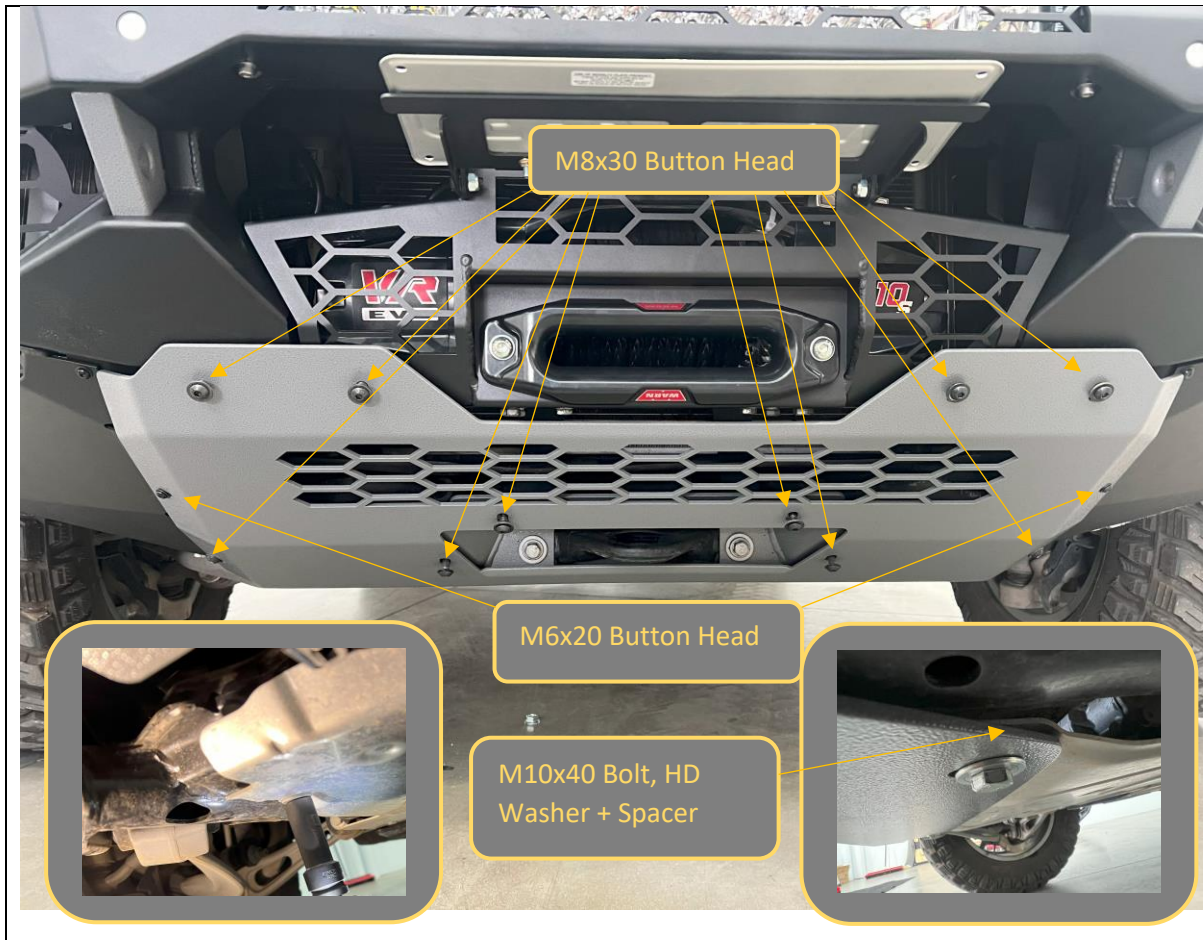

233. Remove 2x front outer bash plate bolts before fitting the center bash plate panel, using 14mm socket.
234. Fit the bash plate to the vehicle, using fasteners shown in the notated image above. Leave all fasteners loose at this stage.
235. Secure back of Center Bash Plate using supplied M10x40 Hex head, M10 HD Flat washer, into the factory thread in chassis, with a P-0394 8MM spacer washer between the Offroad animal bash plate and the factory underbody plate.
236. Progressively tighten the M8 fasteners using 5mm Hex key, to pull the bash plate evenly against the bar and center support.
237. Tighten Bottom fasteners using 16/17MM Socket
238. Tighten M6 fasteners using 4mm Hex Key

#### TOOLS REQUIRED

- 14, 16/17 mm Socket
- 4 mm Hex Key
- 5 mm Hex Key

#### FASTENERS

- 10x M8x30 Button Head
- 10xM8 Flat Washer
- 2x M6x20 Button Head
- 2xM6 Flat Washer
- 2x M10x40 Hex Head
- 2xM10 HD Flat Washer
- 2x P-0394 8MM spacer

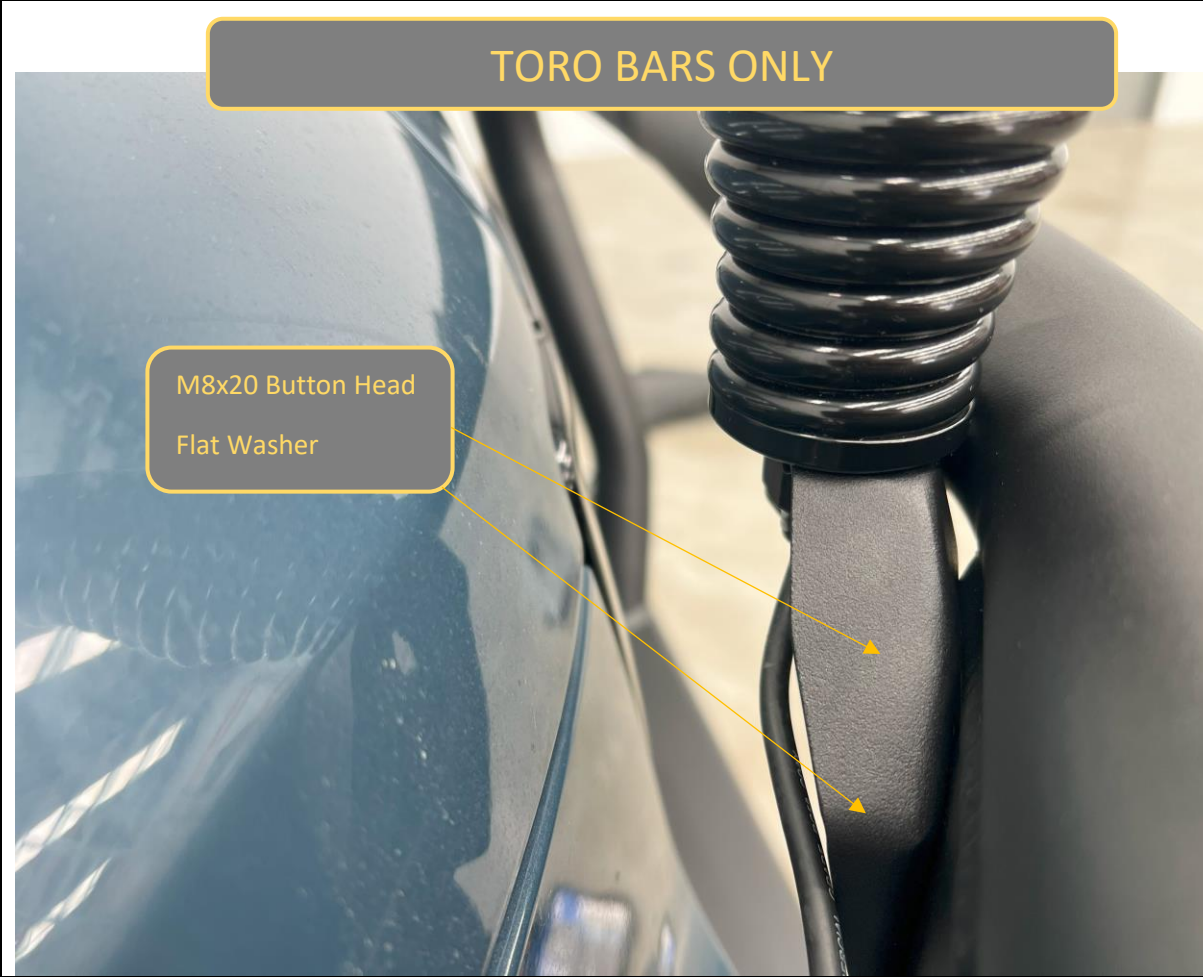

<p>239. If required, fit antenna brackets to the threaded inserts behind bar upright using M8x20 Button Head bolts and Flat Washers.</p> <p>240. Tighten with 5mm Hex Key</p> <p>241. Fit Antenna As required</p>	<p><b>TOOLS REQUIRED</b></p> <p>5mm Hex Key</p>
<p>242. If not fitting antenna brackets retain and supply to customer for future use. Fit M8x20 Button Head bolts and Flat Washers to holes to preserve threads.</p>	<p><b>FASTENERS</b></p> <p>2x M8x20 Button Head Bolt 2xM8 Flat Washer</p>



243. Check all Fasteners are tight.

244. Re-Fit number plate to number plate flip.

245. Head Bush and Enjoy your newly protected Defender!

**For contact details see [www.offroadanimal.com.au](http://www.offroadanimal.com.au)**