



**MAZDA BT-50**  
**MY2021 ON**  
**PREDATOR & TORO FRONT BAR**

**IMPORTANT! – READ BEFORE INSTALLATION**

- When installed in accordance with these instructions, the front protection bar does not affect the operation of the vehicle's SRS airbags.
- This product must be installed exactly as per these instructions using only hardware supplied.
- Take a few moments to read instructions thoroughly before beginning work.
- In the event of damage to any bar component please contact OFFROAD ANIMAL to arrange repair/replacement of components.
- Do not use this product for any vehicle make or model other than that specified on these instructions.
- Do not remove labels from this product.
- This product and its fixings must not be modified in any way unless stated in these fitting instructions.
- The installation of this product is recommended for trained personnel.
- These instructions are correct at time of publication. OFFROAD ANIMAL cannot be held responsible for the impact of any changes subsequently made by the vehicle manufacturer. If you find something has changed please contact us to let us know!
- During installation it is the duty of the installer to check correct operation/clearances of all components.
- If Instructions are to be printed for reference in the workshop, it is recommended that they are printed in colour, for best legibility.

## PARTS LISTING

**IMPORTANT:** Check all parts are present before beginning work! Contact OFFROAD ANIMAL if something is missing.

### Main Parts – In the Box

Qty	Part Number	Description	Image
1	FB-MBT-TF-21-PR-ASM1	Mazda BT-50 TF Predator Front Bar Weldment	
<b>OR</b>			
1	FB-MBT-TF-21-TOR-ASM1	Mazda BT-50 TF TORO Front Bar Weldment	
1	FB-IDM-RG-21-PR-ASM2R	ISUZU DMAX 21+ IMPACT ASSY	
1	FB-IDM-RG-21-PR-ASM2L	ISUZU DMAX 21+ IMPACT ASSY	
1	FB-IDM-RG-21-PR-ASM3L	ISUZU DMAX 21+ TOW POINT ASSY	
1	FB-IDM-RG-21-PR-ASM3R	ISUZU DMAX 21+ TOW POINT ASSY	

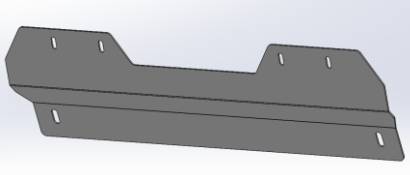
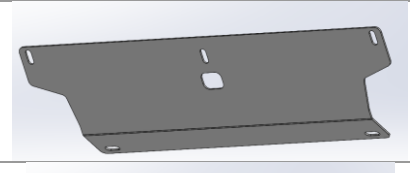
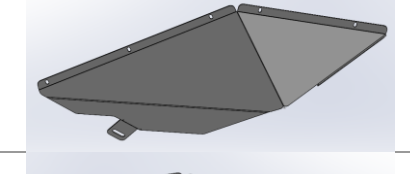
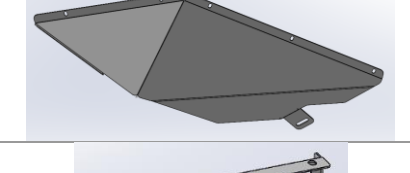
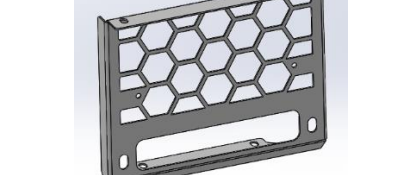
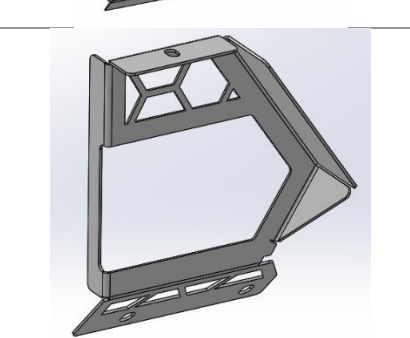
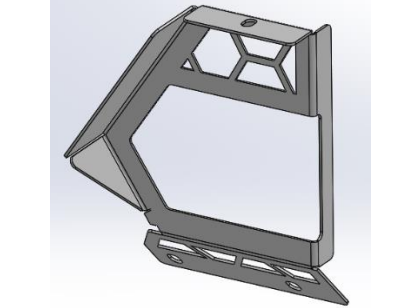
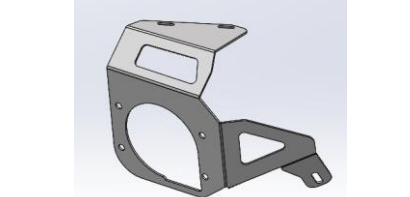
1	U-0036	Isuzu DMAX 2021+ Predator Bash Plate	
1	U-0041	DMAX 21+ Supplementary Underpanel	
1	U-0040L	Mazda BT-50 TF Predator - Side Underpanel	
1	U-0040R	Mazda BT-50 TF Predator - Side Underpanel	
1	M-0014	DMax Predator Center Fairlead Mesh	
1	M-0015L	DMax Predator Side Mesh	
1	M-0015R	DMax Predator Side Mesh	
1	B-0528L	Mazda BT-50 TF Predator - Fog Bracket	

1	B-0528R	Mazda BT-50 TF Predator - Fog Bracket	
1	M-0022R	Mazda BT-50 TF Predator Indicator / Fog Cover Mesh	
1	M-0022L	Mazda BT-50 TF Predator Indicator / Fog Cover Mesh	
1	B-0527	Mazda BT-50 TF Predator - Indicator Bracket	
2	LED Autolamps 80AW	LED AUTOLAMPS 80AW LED INDICATOR PARKER COMBO LIGHT, SINGLE BLISTER PACK	
1	B-0529R	BT50 - 21+ Headlight / Grille support bracket	
1	B-0529L	BT50 - 21+ Headlight / Grille support bracket	
1	B-0530	Mazda BT-50 TF Predator - Center Pan Brace	

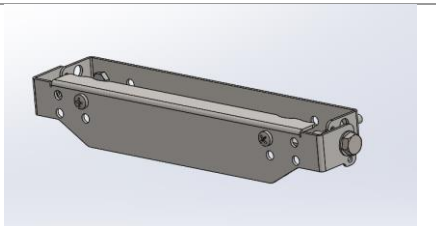
<b>1</b>	NPF-COM-SM-ASM0	Number plate flip asm Small	
----------	-----------------	-----------------------------	--

### Toro Additional Parts

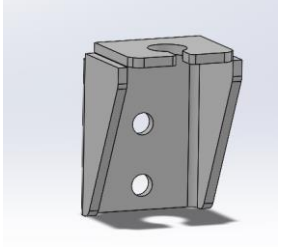
Qty	Part Number	Description	Image
<b>4</b>	B-0649	Toro Antenna Bracket - 90 Degree Tall	
<b>4</b>	M8X20 BHCS BZP	SCREW, BUTTON HEAD CAP, M8X20X1.25, ISO4042 ZnNi BLACK PASSIVATED FINISH	
<b>4</b>	M8 FW BZP	M8 FW- BLACK ZINC	

### Small Parts – Contained in Small Parts Kit Bag

Qty	Part Number	Description
<b>2</b>	FB-IDM-RG-21-PR-ASM4	DMAX 21+ Tow Point Nut Plate
<b>9</b>	M10 FLANGE NUT	Flange Nut, M10x1.5 G8.8 ZP
<b>11</b>	M10 x 30	Bolt Hex, M10X30x[1.5], GR8.8 ZP
<b>11</b>	M10 Flat Washer	M10 FW
<b>16</b>	M12 FW LHD	M12 FW Large Heavy Duty
<b>12</b>	M12X30	Bolt Hex, M12X30x1.75, GR8.8 ZP
<b>6</b>	M12 FLANGE NUT	Flange Nut, M12x1.75 G8.8 ZP
<b>4</b>	M12 Nyloc nut	M12 NYLOC NUT
<b>10</b>	M8 FLAT WASHER- BLACK ZINC	M8 FW- BLACK ZINC
<b>16</b>	M8 X 16 BHCS BZP	SCREW, BUTTON HEAD CAP, M8X16X1.25 GR12.9 BLACK ZP
<b>12</b>	M8 X 20 BHCS BLACK ZINC	SCREW, BUTTON HEAD CAP, M8X20X1.25 BLACK ZP
<b>4</b>	M8 X 30 BHCS BLACK ZINC	SCREW, BUTTON HEAD CAP, M8X30X1.25 BLACK ZP
<b>6</b>	M8 FLANGE NUT	Flange Nut, M8x1.25 G8.8 ZP
<b>10</b>	M6CN3MM	CAGE NUT M6x2.6-3.5

<b>44</b>	M6x16 BHCS BLACK ZINC	SCREW, BUTTON HEAD CAP, M6X16X1 GR12.9 BLACK ZP
<b>40</b>	M6 FLAT WASHER BLACK ZINC	M6 FW BLACK ZP
<b>32</b>	M6 FLANGE NUT	Flange Nut, M6x1 G8.8 ZP
<b>4</b>	M6 X 20 HEX	M6X20 HEX BOLT, ZP, 8.8
<b>2</b>	M5X15 PAN	SCREW, PAN HEAD PHILLIPS, M5X15X0.8 GR4.6 ZP
<b>2</b>	M5 FW	M5 FW
<b>2</b>	M5 FLANGE NUT	Flange Nut, M5x0.8 G8.8 ZP

## TOOLS REQUIRED

The following tools will be required to install the product.

<b>Hand Tools</b>	<b>Power Tools</b>	<b>Workshop Equipment</b>
Metric Socket Set 8-19mm Socket Extension Bar Metric Spanner Set 10-19mm Torx Drivers T25-T30 Hex (Allen) Key Set 4-6mm Trim Puller Tool Flat Blade Screwdriver set Phillips Head Screwdriver set Utility Knife Side Cutters Pliers	Electric Drill 6mm Drill Bit  Air Hacksaw or Angle Grinder  Electric/Air Impact Driver (Optional)	Panel Stand or Soft Blanket Cable Ties Masking Tape Black Automotive paint Scotch Brite or Fine Sandpaper Automotive Sealant/Adhesive Bucket Hose Clamp

# WORKSHOP SAFETY

It is the responsibility of the installer to always complete works in a safe manner. Make sure the following safety equipment is available and precautions are observed whilst fitting this product.

<p>Hearing Protection</p> 	<p>Always wear ear protection when using power tools.</p>
<p>Eye Protection</p> 	<p>Ensure eye protection is always worn when cutting or drilling.</p>
<p>Manual Handling</p> 	<p>Do not attempt to lift bar assemblies or rock sliders on your own.</p> <p>Always use two people to lift or use mechanical lifting aid such as hydraulic lifting trolley.</p>
<p>Vehicle Support</p> 	<p>Always ensure vehicle is properly supported when working on it. Do not attempt to fit products whilst suspension work is being carried out. Do not work under a vehicle supported only by a jack.</p>



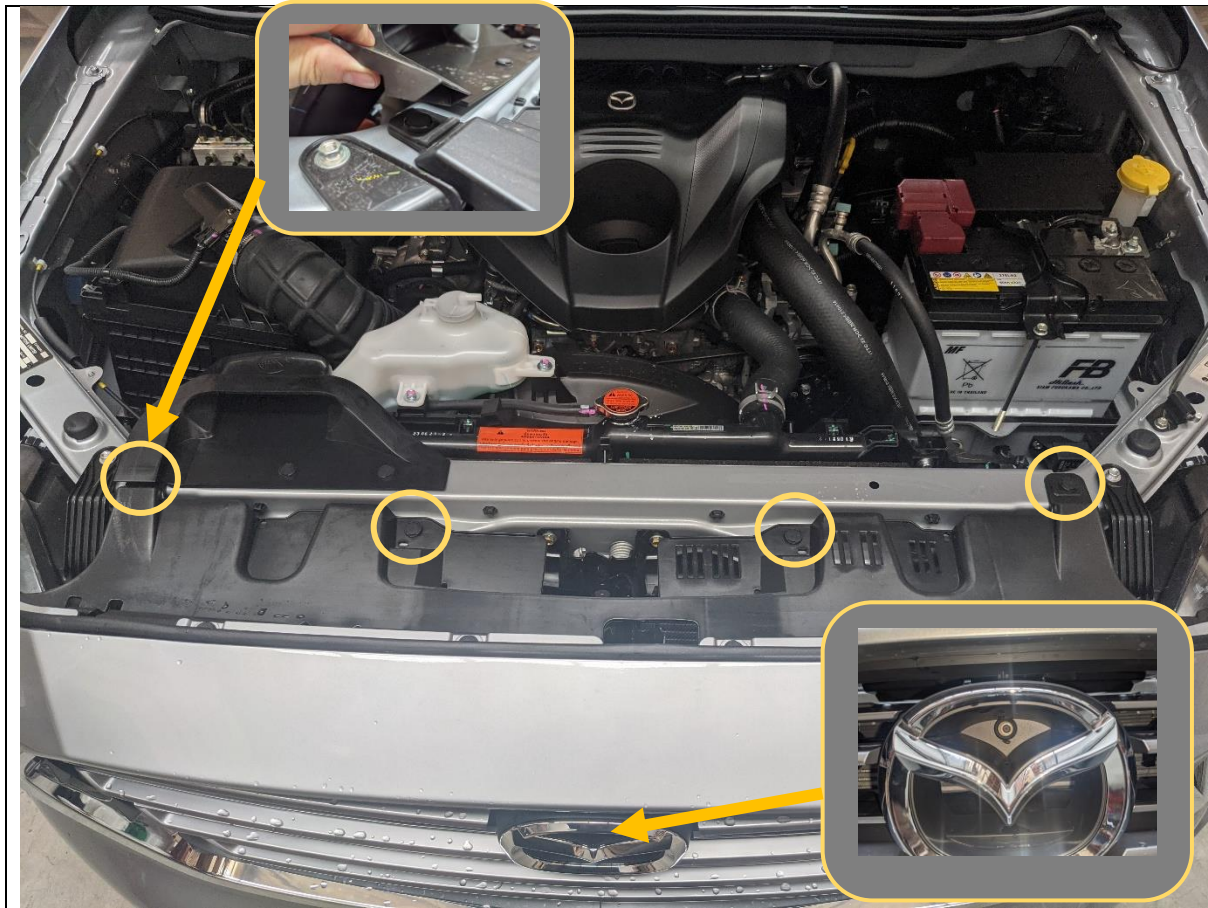

1. Open the Bonnet.
2. Remove the 4x Clips securing the top of the grille by levering up center part using small flat blade screwdriver
3. Remove phillips head screw securing center of grille inside the "Mazda" badge.

**TOOLS REQUIRED**  
Small Flathead Screwdriver  
Phillips Head screwdriver

**FASTENERS**  
  
Retain Factory Clips and Screw



4. Remove the three screws securing the bottom edge of the bumper, using 10mm Socket / Spanner

**TOOLS REQUIRED**  
10mm socket / spanner

**FASTENERS**



5. Remove the clips on the underside of the wheel arch by the bumper to quarter panel seam, and under the bottom of the bumper near wheel as shown.
6. Remove using same technique as other clips
7. Remove the 10mm nut securing bottom of bumper.
8. Repeat for other side of vehicle

**TOOLS REQUIRED**  
10mm socket  
Trim Tool

**FASTENERS**  
Factory Clip and Nut





9. Remove top grille trim by pulling outward from the bottom in the locations shown to release the clips
10. Remove the clips securing the black plastic air guide to the top of the grille.
11. Remove and set aside the top black plastic air guide.

**TOOLS REQUIRED**

Small flat blade screwdriver

**FASTENERS**

Factory Clips

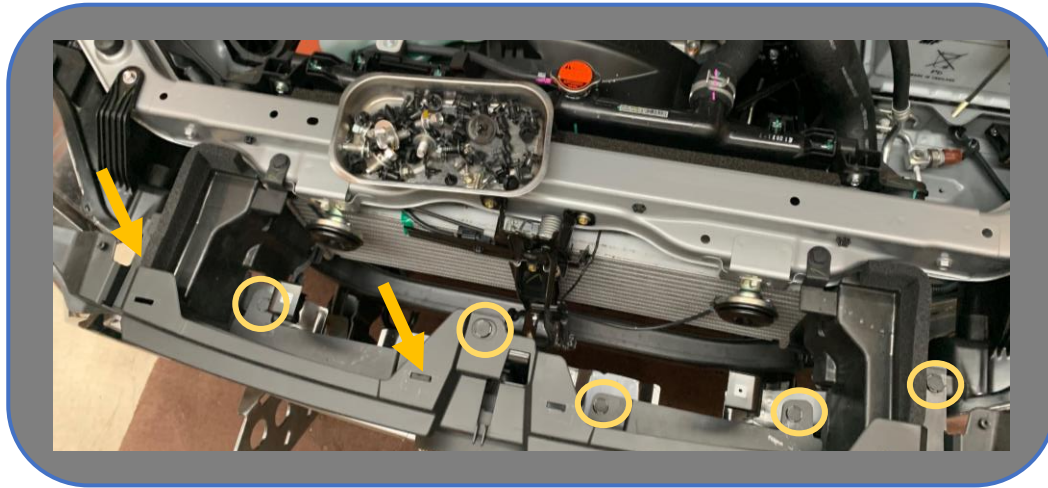

12. Remove the clips securing the Grille to the vehicle

**TOOLS REQUIRED**

Small flat blade screwdriver

**FASTENERS**

Factory Clips



13. Remove the clips securing the bumper to the vehicle
14. Release the bumper clips by pulling bumper away from bottom of headlights, starting from the outside and working in.
15. When bumper is loose, reach in and disconnect the wiring harness located under the left-hand headlight.
16. Remove bumper from car and set aside on soft blanket or panel stand.

**TOOLS REQUIRED**

Small flat blade screwdriver

**FASTENERS**

Factory Clips



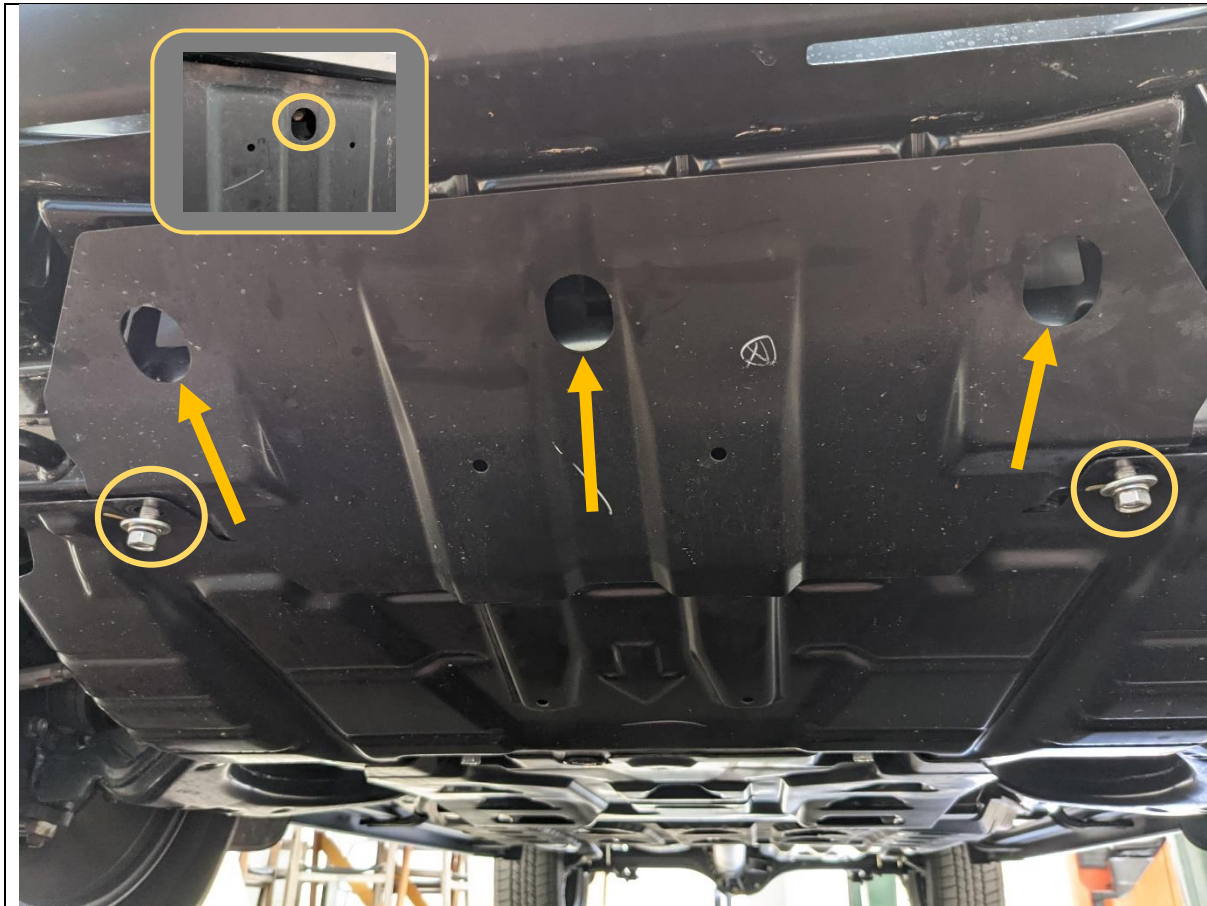

17. Remove the front skid plate by removing the 5x 14mm head bolts securing it to the chassis. Note 3x of the bolts are recessed into the skid plate, shown with arrows.

**TOOLS REQUIRED**

14mm socket  
Short extension bar

**FASTENERS**

Factory 14mm head bolts.  
Retain for refitment.



18. Remove the 4x 14mm head bolts that secure the impact beam to the chassis

19. Remove and discard the impact beam. Retain bolts for fitting of mount.

**TOOLS REQUIRED**  
14mm socket

**FASTENERS**

Retain for re-fitment of mounts



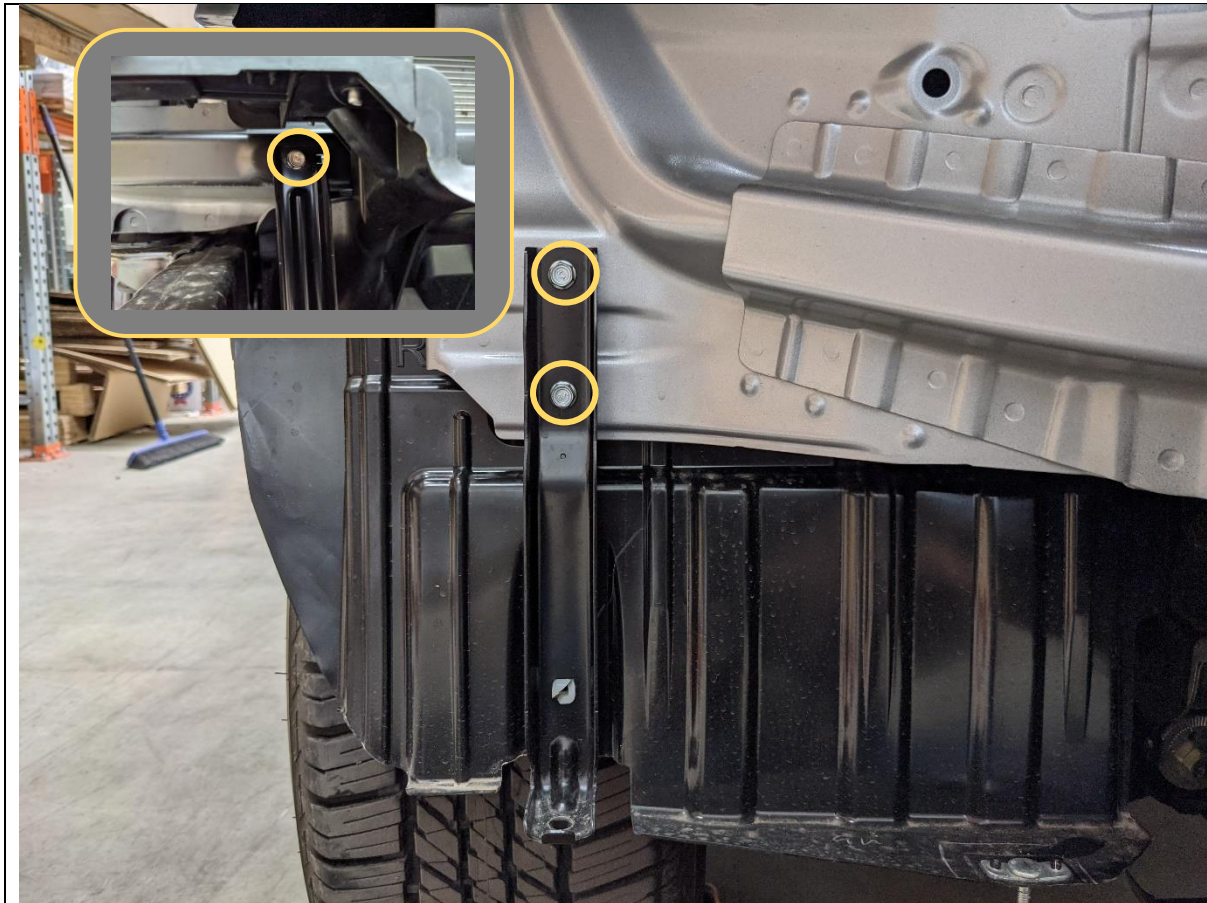

- 20. Remove the 10mm bolts securing the bottom bumper supports.
- 21. Remove and discard the bumper supports

**TOOLS REQUIRED**

10mm socket

**FASTENERS**

Factory 10mm head bolts  
Discard

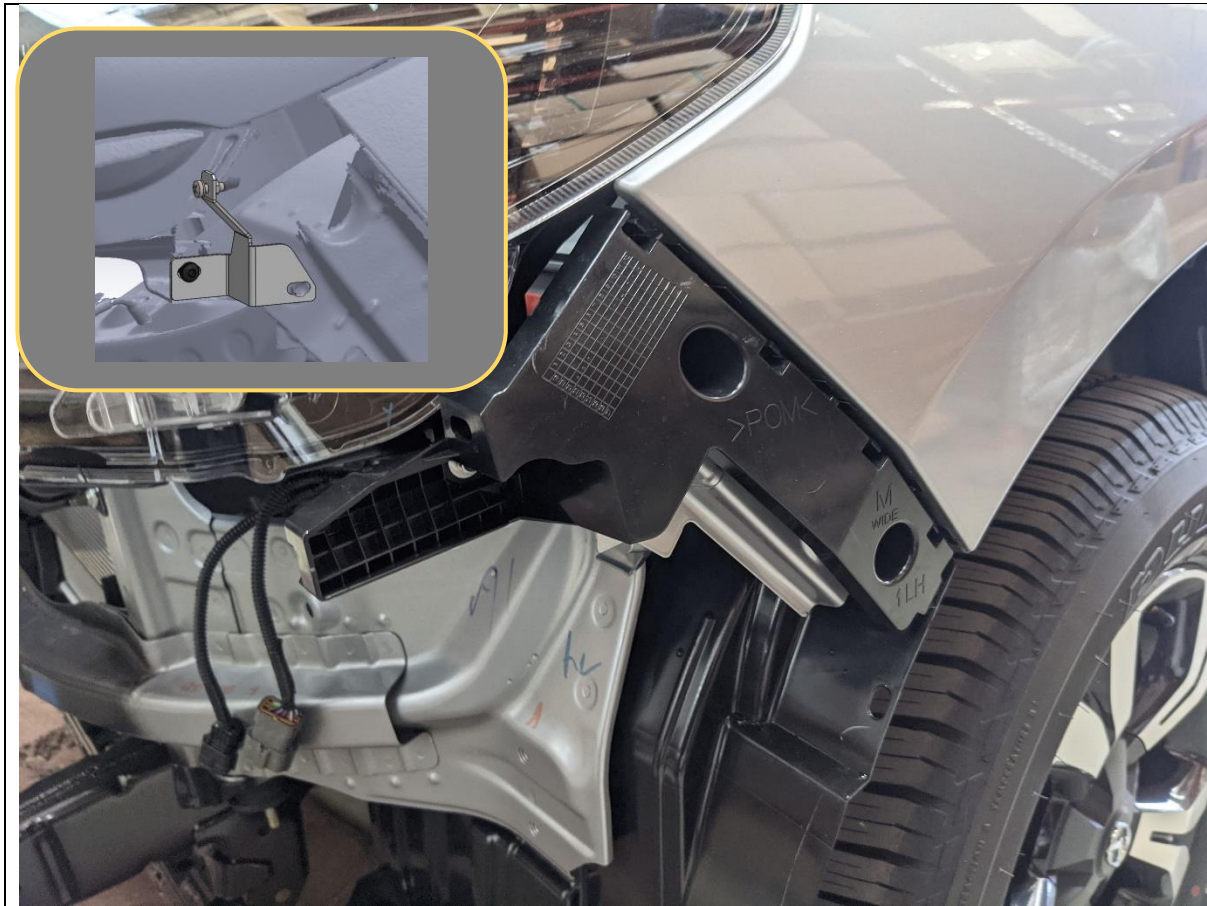

22. Remove the 10mm and Philips head screws securing the plastic bumper supports beside the headlights. Retain the screw that secures the bumper support to the headlight.
23. Remove the bumper supports, a firm tug will be required to release the clips. Discard
24. Fit the headlight support bracket between the fender and headlight. Re-use factory bolt to secure bracket to headlight and use M6x16 flat washer and flange nut to secure to fender.
25. Complete on both sides of vehicle

**TOOLS REQUIRED**

Phillips head screwdriver

**FASTENERS**

Factory Bolt.  
1x M6x16 Button Head  
1x M6 Flat Washer  
1x M6 Flange Nut



26. Remove and discard the black plastic air guide. Release clips using small flat screwdriver as per other clips on vehicle.

**TOOLS REQUIRED**  
Utility knife or  
air hacksaw

**FASTENERS**



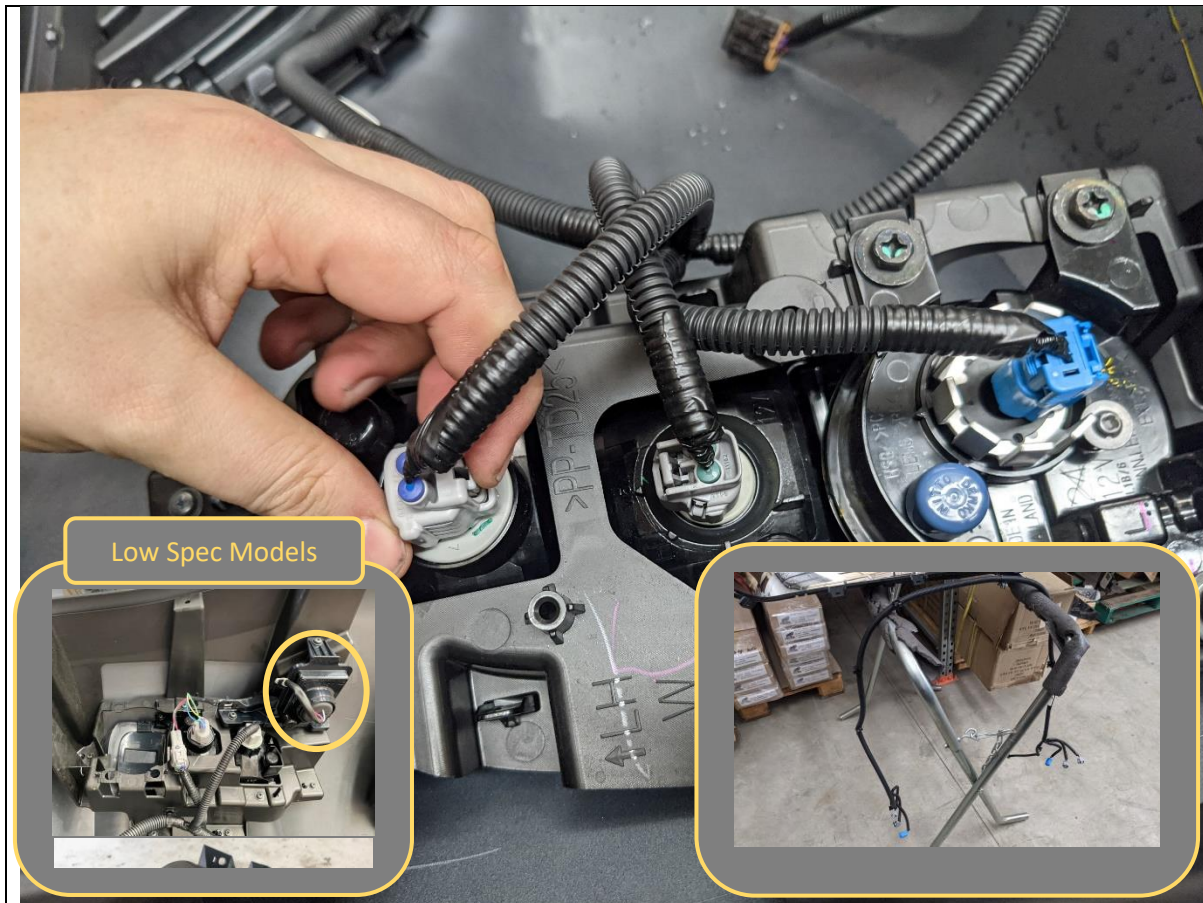

27. Unplug the electrical connectors from the fog light and indicators.
28. Remove the harness clips from the bumper using a trim tool.
29. Set aside harness for re-fitment to Offroad Animal Bar.
30. If equipped, remove the parking sensors and parking sensor harness from the bumper.
31. Low spec models will have a black box that a loom enters, these are not sensors. Remove box from bumper and retain with cables, and cable tie back to loom.

**TOOLS REQUIRED**  
Trim Tools

**FASTENERS**



- 32. Remove fog lights from the bumper using Phillips head screwdriver.
- 33. Discard the factory Philips head screws.

**TOOLS REQUIRED**  
Phillips head screwdriver

**FASTENERS**  
OE Philips head screws





34. Separate the grille from the lower bumper by progressively releasing the tab style clips, starting from one edge working across the grille.

A flat screwdriver can assist in releasing the clips

35. Discard the lower half of bumper.

**TOOLS REQUIRED**

Flat Screwdriver

**FASTENERS**

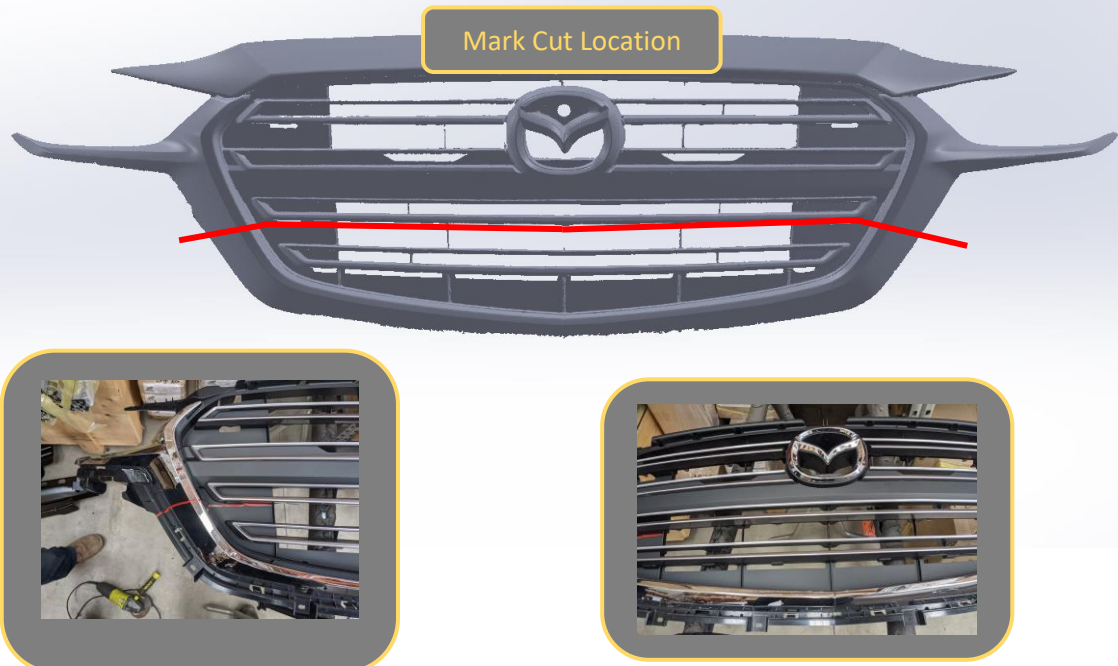
	
<p>36. Mark location of grille cut on grille, just below the first "Bar" Below the Mazda badge, as per the above image.</p>	<p><b>TOOLS REQUIRED</b> Paint Pen</p>
	<p><b>FASTENERS</b></p>



- 37. Perform cut along marked line using angle grinder, Oscillating multi tool or Air Hacksaw.
- 38. Discard lower part of grille.

**TOOLS REQUIRED**  
Angle Grinder, Oscillating multi tool or Air Hacksaw

**FASTENERS**



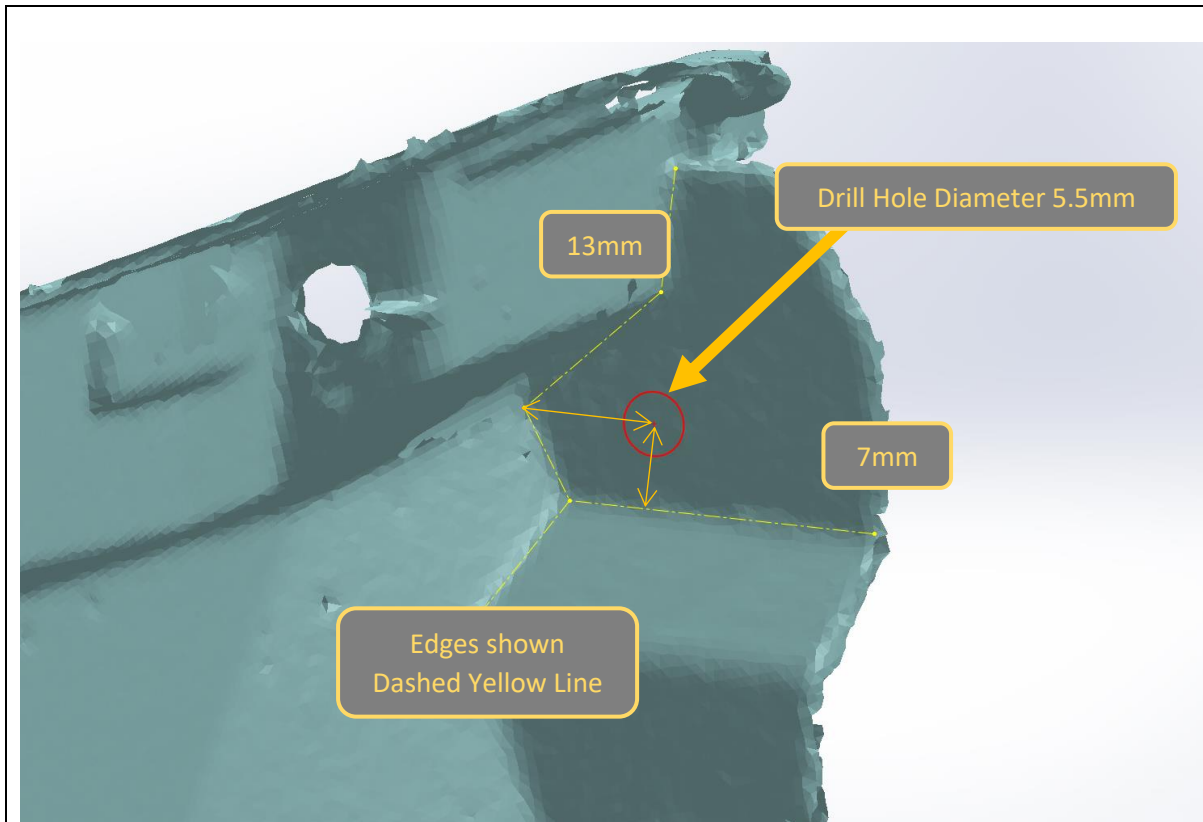

<p>39. Measure and mark holes in back corner of grille as shown in image above.</p> <p>40. Drill holes to 5.5mm.</p>	<p><b>TOOLS REQUIRED</b></p> <p>5.5mm Drill Bit Electric Drill Marker</p>
	<p><b>FASTENERS</b></p> <p>M5x15 Screw M5 Flat Washer M5 Flange Nut</p>

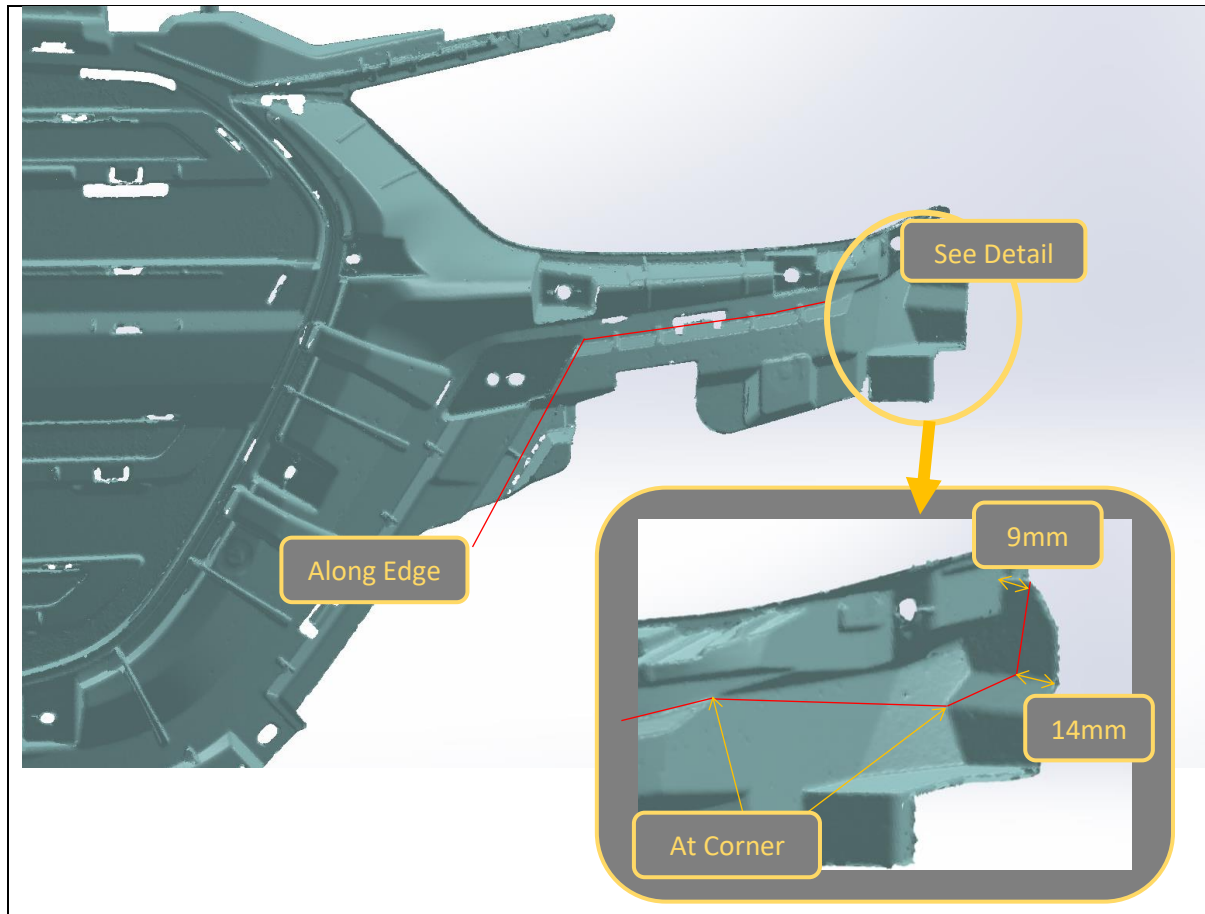

41. Mark secondary trim to remove the black plastic parts under the chrome trim as shown in image.  
  
Take care to mark the cut at the far tips of trim exactly as per the image shown.
42. Perform second cut along marked lines using Oscillating multi tool or Air Hacksaw.
43. Repeat mirrored for opposite side of vehicle

**TOOLS REQUIRED**  
Oscillating multi tool  
Air Hacksaw

**FASTENERS**  
M5x15 Screw  
M5 Flat Washer  
M5 Flange Nut

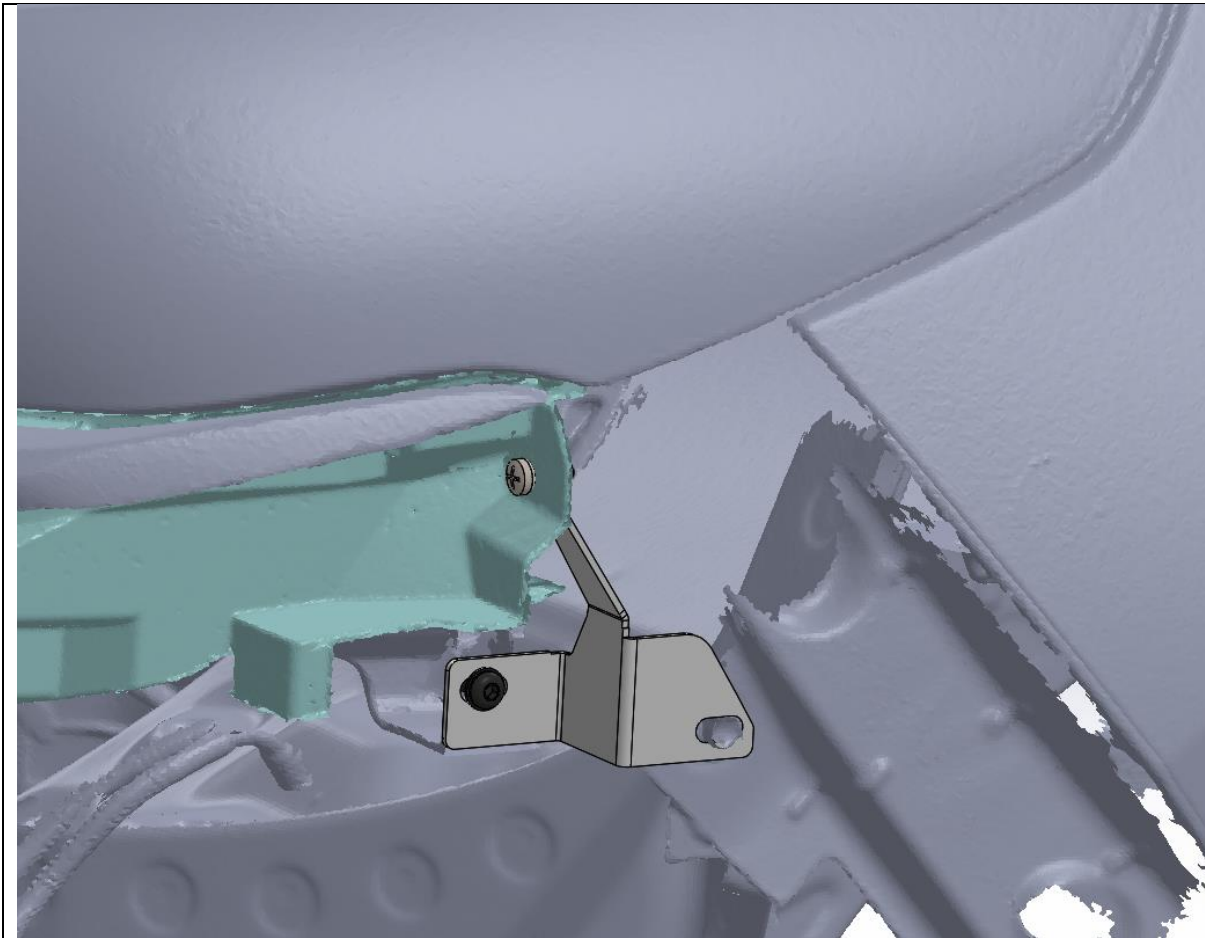

- 44. Re-Fit grille to the vehicle.
- 45. Fit the outer grille support bracket between the headlight and fender, using M6x16 Button head bolt into headlight and factory bolt for fender.
- 46. Fit the outer grille support bracket to the grille through the hole drilled earlier, using the M5 Hardware supplied.

**TOOLS REQUIRED**  
4mm Allen Key  
Phillips Head Screwdriver

**FASTENERS**  
1x M6x16 Button Head Screw  
1x M6Flat Washer  
1x M5x15 Pan Head Screw  
1x M5Flat Washer  
1x M5 Flange Nut  
Per side



- 47. Fit the indicator mount bracket to the light mounting Mesh Panel using supplied M6x16 button head screws, flat washers, and flange nuts. Indicator bracket sits on top of the mesh panel as shown.
- 48. Fit the indicator lamp supplied using hardware supplied in lamp package. Lights sit on the forward side of the bracket.

**TOOLS REQUIRED**  
4mm Allen Key

**FASTENERS**  
2x M6x16 Button Head Screw  
2x M6Flat Washer  
2x M6 Flange Nut  
  
Per side





49. Fit the factory Fog lights to the fog light brackets using supplied M6x16 button head screws, flat washers, and flange nuts.

**TOOLS REQUIRED**  
4mm Allen Key

**FASTENERS**

4x M6x16 Button Head Screw  
4x M6 Flat Washer  
4x M6 Flange Nut



- 50. Fit the fog lamp bracket to the light mesh using M6x20 Bolts, flat washers, and flange nuts.
- 51. Insert the assembled light bracket / mesh panel into the wing of the bar.
- 52. Secure to wing brace with supplied M6x16 button head bolts, washers, and flange Nuts

**TOOLS REQUIRED**  
4mm Hex Key

- FASTENERS**
- 1x M6x16 Button Head Screw
  - 1x M6 Flat Washer
  - 1x M6 Flange Nut
  - 2x M6x20 Hex
  - 2x M6 Flat Washer
  - 2x M6 Flange Nut

Per side



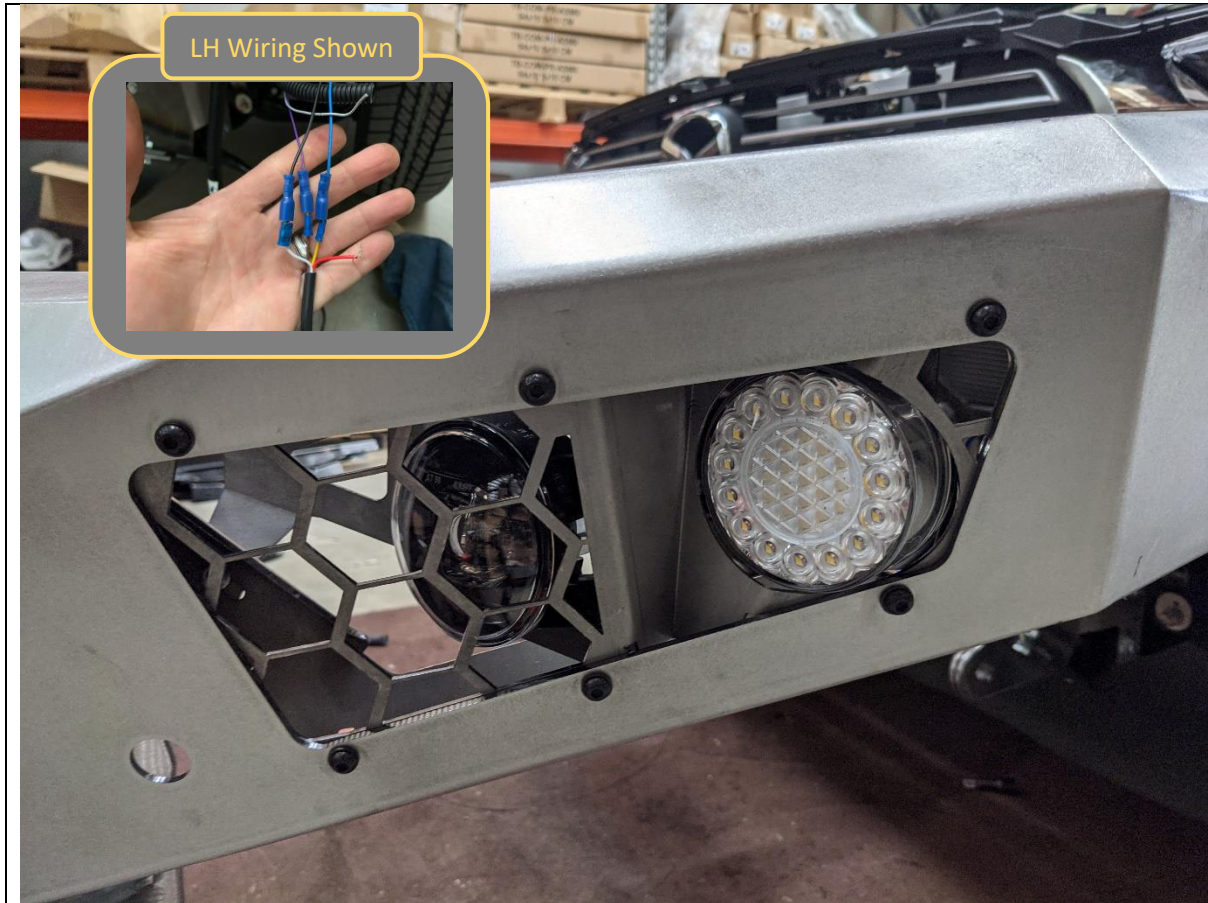

- 53. Secure Light assembly to the wing of bar using with supplied M6x16 button head bolts, washers, and flange Nuts
- 54. Re install wiring harness to bar and plug in connectors for fog light.
- 55. Cut off connectors for park and indicator lamps and complete wiring for the Indicator / Parker Lamp as follows.

Function	Loom Wire Colour	Lamp Wire Colour
Earth	Black + Grey	White
Parker Lamp	Blue	Yellow
Indicator LH	Purple	Brown
Indicator RH	Light Blue	Brown
DRL (Not Used)	N/A	Red

Test connections once complete.

- 56. If equipped, re fit parking sensors to bar by relocating original housings to the holes on the bar.

**TOOLS REQUIRED**  
4mm Hex Key  
Crimping Tool or Soldering iron

**FASTENERS**

Crimp Connectors  
6x M6x16 Button Head Screw  
6x M6 Flat Washer  
6x M6 Flange Nut

Per Side



<p>57. If fitting an integrated light bar, do so now.</p> <p>58. The bar is designed to fit a Offroad Animal 22 inch light bar. If fitting this light bar, assemble bar with legs out, and it will line up with the slots in the center gusset. Secure with fasteners supplied with the light bar. The bar can accommodate most other “20 inch” size light (20-22 inch long) bars</p>	<p><b>TOOLS REQUIRED</b> Refer to light bar instructions</p>
<p>59. If fitting stealth top hoop or round lights do so at this stage.</p> <p>60. After light bar is fitted, fit the center pan brace between the Gusset and Cradle using supplied M6 Fasteners</p>	<p><b>FASTENERS</b> Supplied with Light bar M6x16 Button Head M6x12 Button Head 2x M6 Flat Washer 2x M6 Flange Nut</p>





61. Fit 5x cage nuts from small parts kit to rectangular slots in bottom of wing.

Use a small flat bladed screwdriver to push the edge of the cage to engage with the slot to aid fitting.

**TOOLS REQUIRED**  
Flat Blade Screwdriver

**FASTENERS**

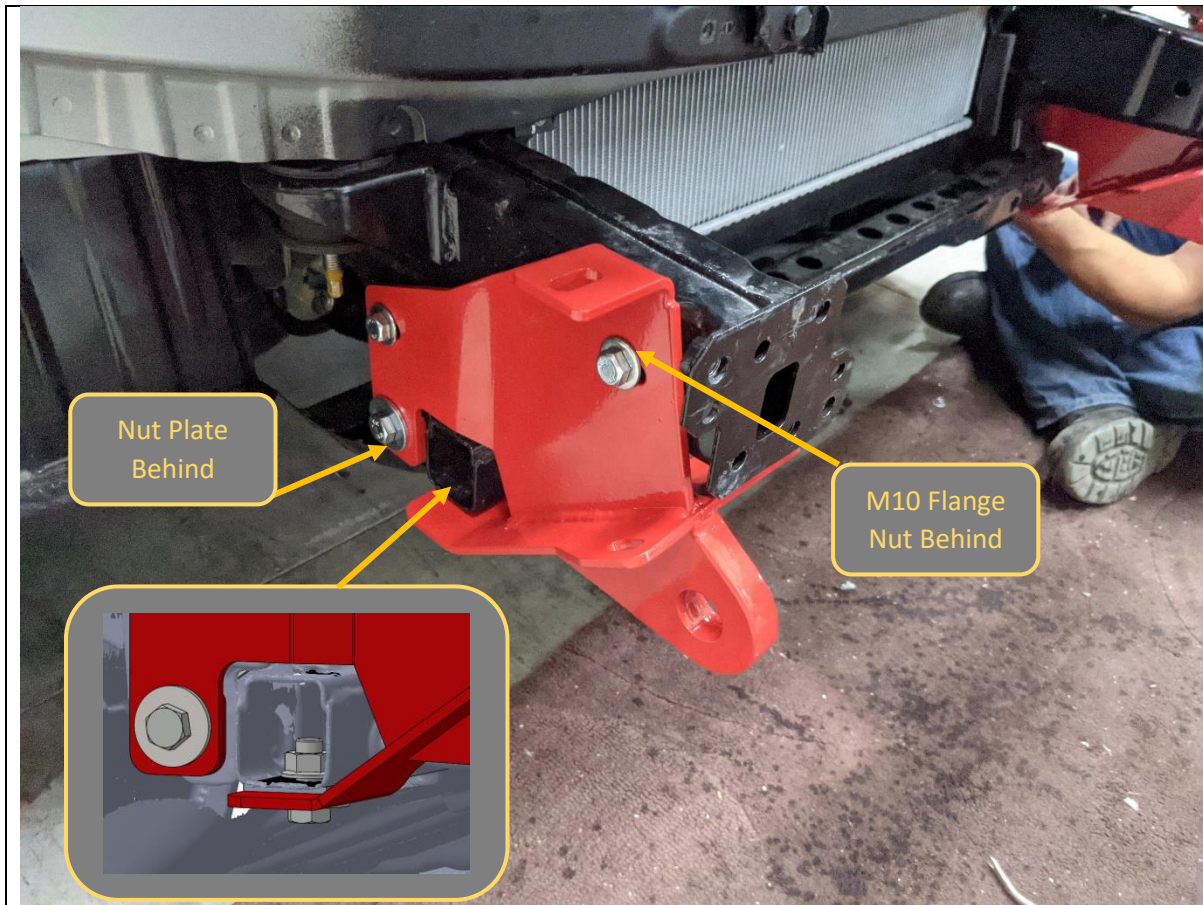

62. Fit the Tow Point to the chassis using a M10 Flange Nut behind the center of the chassis rail and the M10 / M12 nut plate behind the rear section of chassis. Use M12X30 bolt with flange nut inside chassis rail for bottom of mount.

63. Secure in place to threaded mounting points in chassis using original factory bolts. Leave bolts loose at this stage.

**TOOLS REQUIRED**

**FASTENERS**

- 2x M10x30
- 1x M10 Flange Nut
- 2x M12x30 Bolt
- 1x M12 Flange Nut
- 2x M10 Flat Washer
- 2x M12 Flat Washer
- 1x M10 + M12 Nut Plate

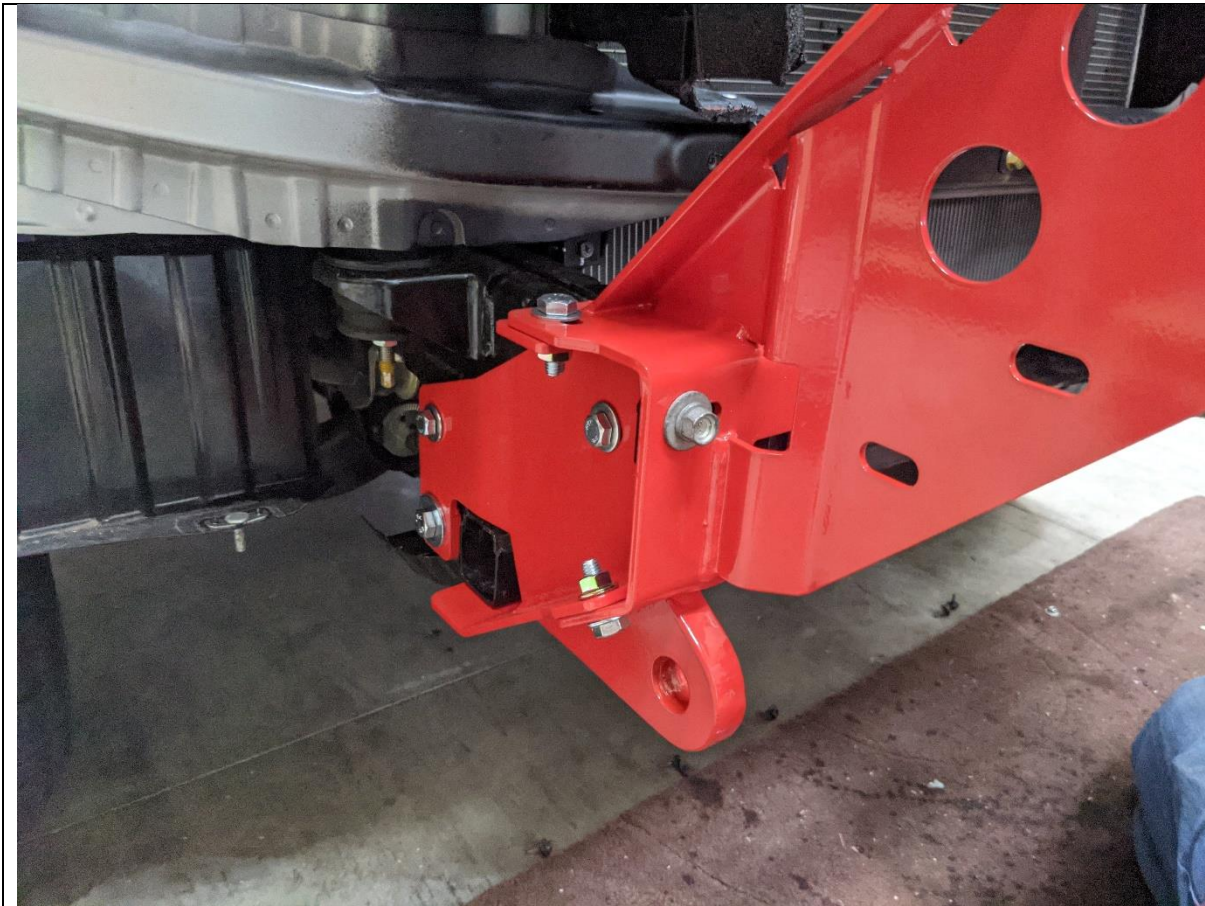

- 64. Fit the impact assembly to the chassis using the 14mm head factory bolts retained from the crash beam.
- 65. Secure to the tow point using 3x M10x30 bolts, flat washers and flange nuts as shown.
- 66. Repeat for both sides of vehicle. Leave finger tight at this stage

**TOOLS REQUIRED**

**FASTENERS**

- 2x Factory M10x1.25P Bolts
- 3x M10x30 Hex Bolt
- 3x M10 Flat washer
- 3x M10 Flange Nut

**Per Side**



<div data-bbox="671 237 963 331" data-label="Section-Header"> <p><b>MEASURE</b></p> </div> <div data-bbox="233 367 1362 663" data-label="Image"> </div>	
<div data-bbox="647 757 940 851" data-label="Section-Header"> <p><b>Adjust</b></p> </div> <div data-bbox="450 860 1139 1050" data-label="Image"> </div>	
<p>67. Measure distance between bullbar uprights with tape measure. Note down this distance</p> <p>Distance = _____</p> <p>68. Measure and adjust the distance between the mounts on the vehicle to be 2-5mm greater than the distance measured.</p> <p>69. Tighten all bolts securing impact assembly and tow point, and re check distance. Re adjust as required to achieve correct distance.</p>	<p><b>TOOLS REQUIRED</b></p> <p>13mm Socket 14mm Socket 16mm Socket</p> <hr/> <p><b>FASTENERS</b></p>

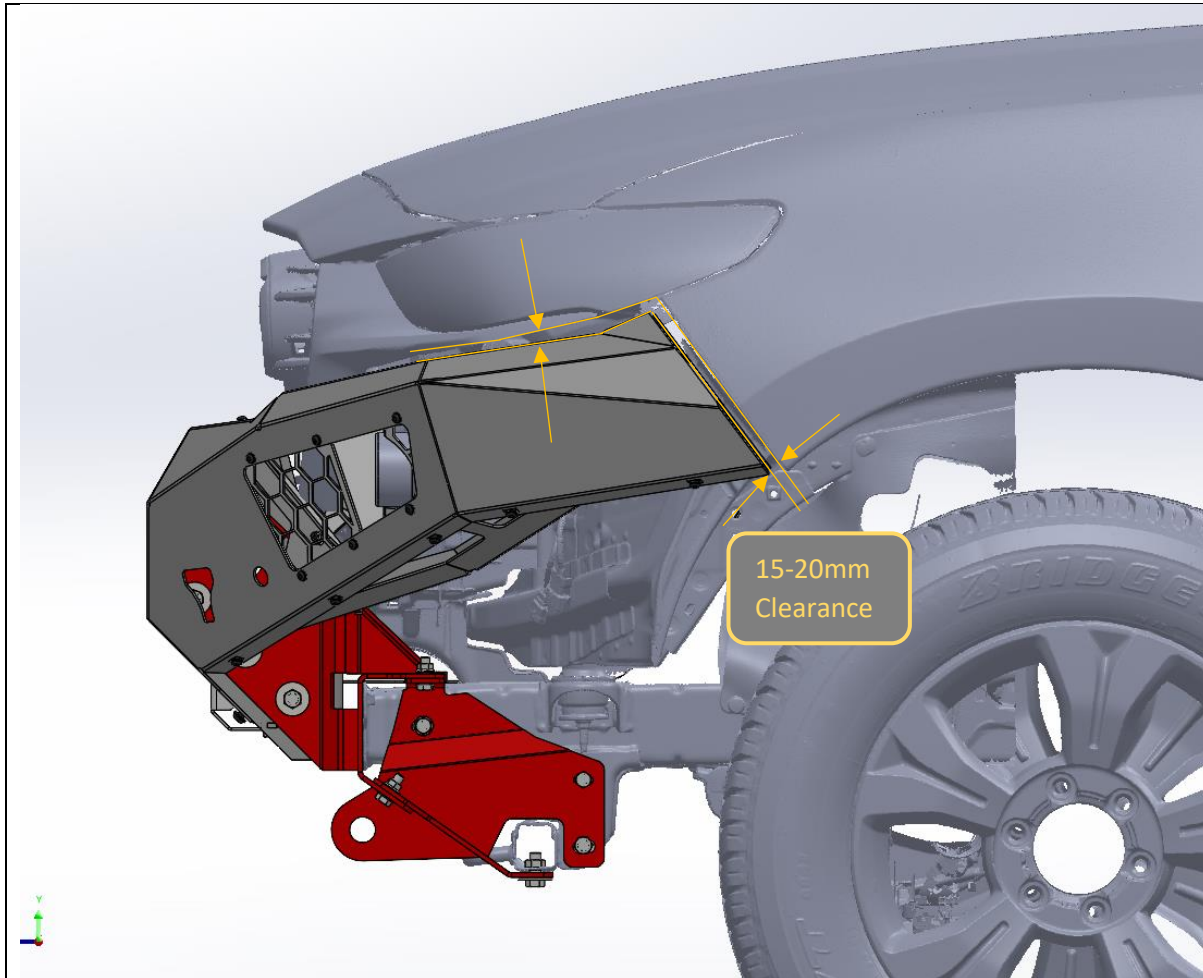

70. With assistance, either from another person or a lifting trolley, lift the bar onto the mounts on the vehicle.

71. Secure bar to mount with 4x M12x30 Bolts, heavy duty washers and 3x M12 Nyloc and 1x M12 flange nut per side. Finger tight at this stage.

72. With assistance, from another person, align the bar with the edges of the vehicle. Adjust such that the clearances are neat and even side to side. When happy, tighten the bolts with the flange nut to lock the bar in position.

Acceptable range of clearances shown in image above. **The clearances must be maintained all the way under the headlight areas.**

Ensure the bar does not touch any parts of the body or grille

73. Once in position, tighten the M12 bolts using socket and spanner. An impact driver may be used to speed up this process.

**TOOLS REQUIRED**

Lifting Trolley  
19&18mm Socket and Spanner

**FASTENERS**

8x M12x40 Bolt  
16x M12 Heavy Duty Large Washer  
8x M12 Nyloc Nut



<p>74. If fitting a winch, do so now.</p> <p>75. The bar is designed to fit most low mount winches, in foot down configuration. WARN ZEON 10 is largest winch confirmed to fit.</p> <p>76. The control box can be mounted on top of the winch. Winches usually come with a bracket to allow this. Refer to winch manufacturer.</p>	<p><b>TOOLS REQUIRED</b></p> <p>Refer to winch Instructions</p>
	<p><b>FASTENERS</b></p> <p>Refer to Winch instruction.</p>

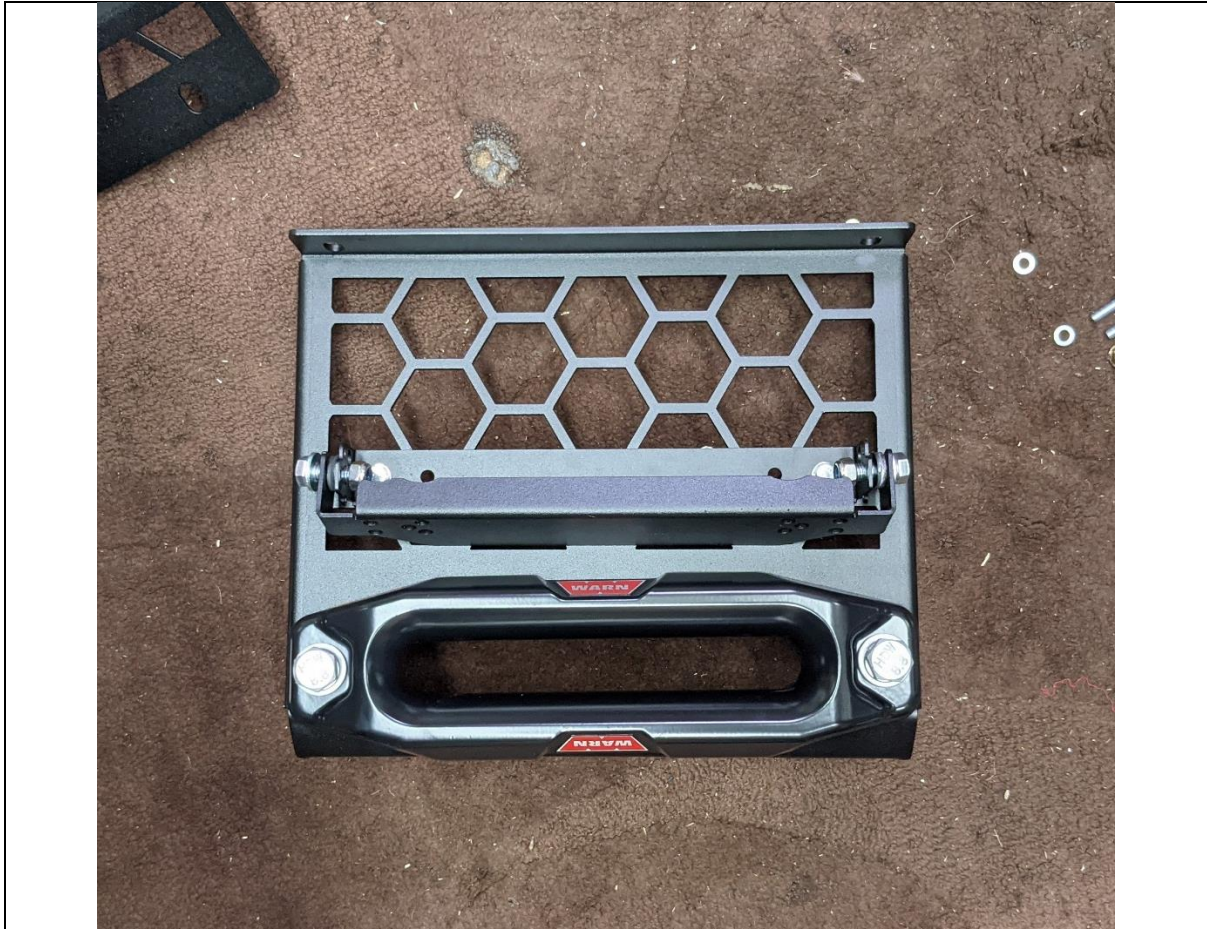

<p>77. Prepare the center mesh panel for fitment.</p> <p>78. If required, fit winch fairlead to Mesh Fairlead Mount (M-0014). Use M10 or 3/8" fasteners supplied with winch. The bar is only compatible with Hawse type fairleads.</p> <p>79. Fit number plate flip kit to fairlead mount, using fasteners supplied in kit.</p>	<p><b>TOOLS REQUIRED</b></p> <p>Depends on winch supplied fasteners</p>
	<p><b>FASTENERS</b></p>





- 80. Fit the Mesh Fairlead Mount (M-0014) to the center of the bar, using M8x16 Button head (Top), M8x20 Button Head (Bottom) M8 Flat Washers and M8 Flange Nuts.
- 81. Tighten fasteners using 13mm socket / spanner and 5mm Allen Wrench.

**TOOLS REQUIRED**

- 13mm Spanner
- 5mm Allen Wrench**

**FASTENERS**

- 2x M8x16 Button Head
- 2x M8x20 Button Head
- 4x M8 Flange Nut
- 4x M8 Flat Washer





- 82. Fit Mesh Infill Panels (M-0008L/R). Secure with M8x16 button head bolt and M8 flat washer into the threaded insert in bar for top mount. The flange of the infill panel should sit on the inside of the bar.
- 83. Don't fit any bolts to bottom holes at this stage.
- 84. Tighten top fasteners using 5mm Allen Wrench.

**TOOLS REQUIRED**  
5mm Allen Wrench

**FASTENERS**

2x M8x16 Button Head  
2x M8 Flat Washer



85. Re-connect light and parking sensor (if equipped) wiring connectors.

**TOOLS REQUIRED**

**FASTENERS**

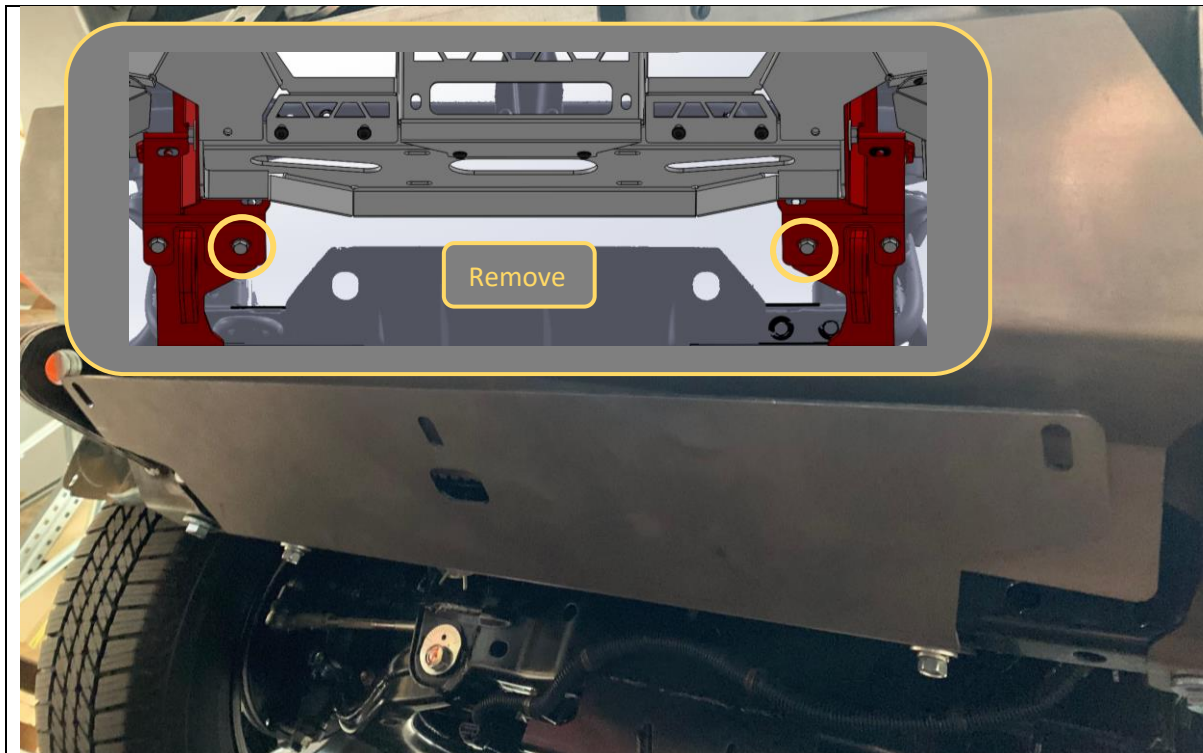

<p>86. Before fitting bash plate, remove the M10x30 Bolt on the inside of the tow point / impact assembly joint.</p> <p>87. Fit Center Bash Plate using M8x20 button head, flat washer and flange nut to front face. Ensure these fasteners pass through the side mesh panels.</p> <p>88. Fit secondary bash plate to chassis crossmember using OE bolts removed from factory guard in same location.</p>	<p><b>TOOLS REQUIRED</b></p> <p>16/17mm Spanner 16/17mm Socket 5mm Allen Key 13mm spanner</p>
<p>89. Secure back of Center Bash Plate and front of secondary bash plate using M10x30 hex head, flat washers and M10 flange nut removed in previous step, through the tow point / impact assembly parts.</p> <p>90. Use additional M10x30 hex head, flat washer and M10 flange nut to secure center point on Bash plates</p> <p>91. Tighten All bottom fasteners using 16/17mm spanner &amp; socket</p> <p>92. Tighten front fasteners using 13mm socket / spanner and 5mm Allen Wrench. Reach through access hole in mesh panel to reach nut.</p>	<p><b>FASTENERS</b></p> <p>4x M8x20 Button Head 4x M8 Flange Nut 4x M8 Flat Washer</p>





- 93. Remove the outside top bolts from impact assembly/tow point.
- 94. Fit the side under panels by first sitting the bottom mount on top of the impact assembly, then inserting the 5x M6x16 bolts into the cage nuts fitted earlier
- 95. Tighten with 4mm Allen wrench
- 96. Secure bottom of side under panel to mount using bolt removed from joint earlier.
- 97. Tighten with 16/17mm spanner / socket

**TOOLS REQUIRED**  
16/17mm Spanner  
5mm Allen Wrench  
4mm Allen Wrench

**FASTENERS**  
10x M6x16 Button Head  
10x M6 Flat Washer



- 98. Using a sharp utility knife, cut back the plastic inner wheel arch liner to match the profile of the under panel.
- 99. Tuck the wheel arch liner behind the flanges on the under panel.
- 100. Repeat for both sides of vehicle.

**TOOLS REQUIRED**  
Utility Knife

**FASTENERS**

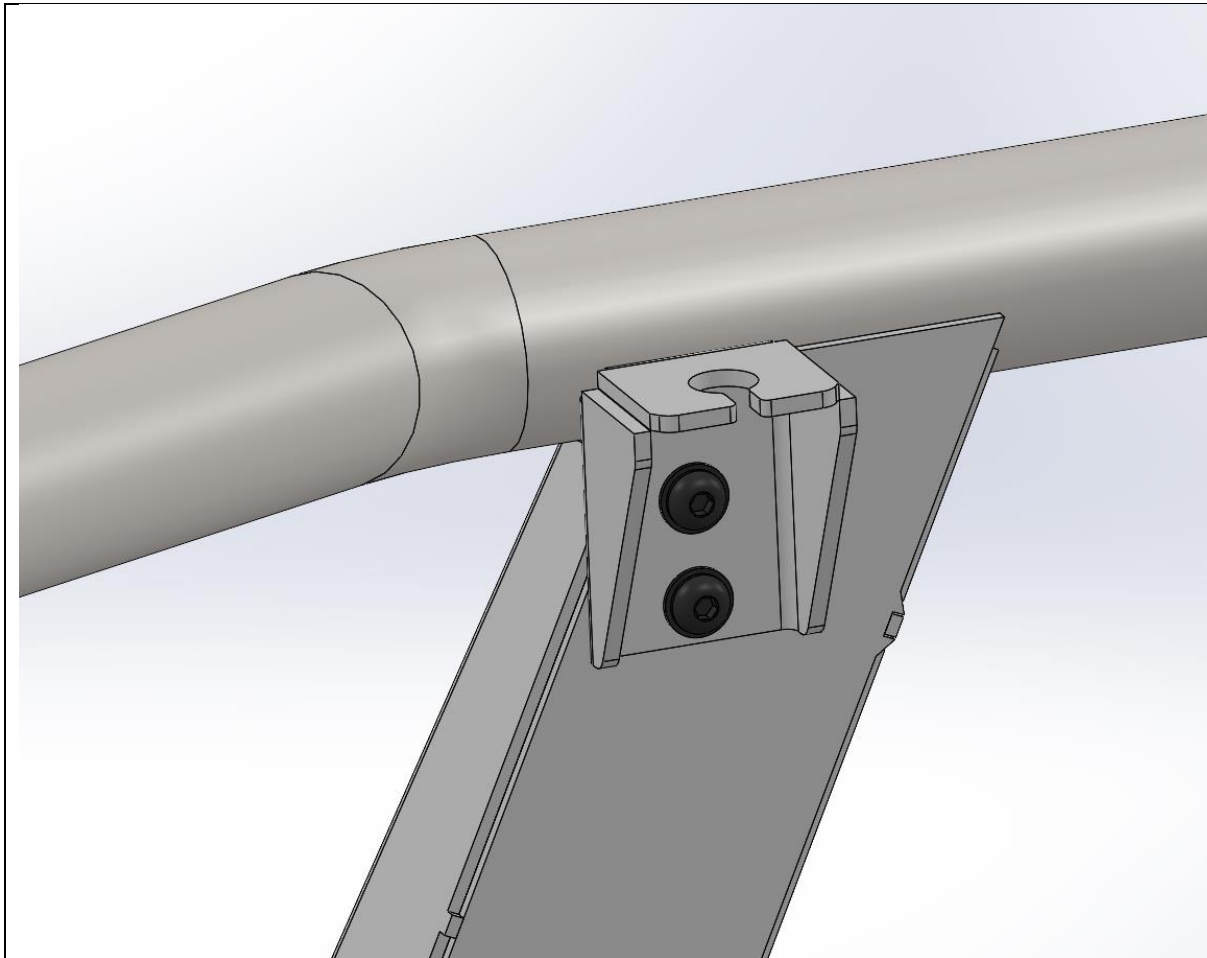

<p>101. TORO ONLY. If required fit antenna brackets to the captive nuts in the back of the toro bar uprights, using M8x20 Button head screws and flat washers.</p> <p>102. Retain any un-used antenna brackets and supply to customer for future use</p>	<p><b>TOOLS REQUIRED</b> 5MM Hex Key</p>
	<p><b>FASTENERS</b> 2x M8x20 BHCS Black 2x M8 Black Washer</p>





<p>103. Re-check that all fasteners are tight.</p> <p>104. Re-fit number plate to number plate flip.</p> <p>105. You're done. Hit the tracks and enjoy your newly protected BT-50!</p>	<p><b>TOOLS REQUIRED</b></p>
	<p><b>FASTENERS</b></p>