



ISUZU MU-X MY2021 ON PREDATOR & TORO FRONT BAR

IMPORTANT! – READ BEFORE INSTALLATION

- When installed in accordance with these instructions, the front protection bar does not affect the operation of the vehicle's SRS airbags.
- This product must be installed exactly as per these instructions using only hardware supplied.
- Take a few moments to read instructions thoroughly before beginning work.
- In the event of damage to any bar component please contact OFFROAD ANIMAL to arrange repair/replacement of components.
- Do not use this product for any vehicle make or model other than that specified on these instructions.
- Do not remove labels from this product.
- This product and its fixings must not be modified in any way unless stated in these fitting instructions.
- The installation of this product is recommended for trained personnel.
- These instructions are correct at time of publication. OFFROAD ANIMAL cannot be held responsible for the impact of any changes subsequently made by the vehicle manufacturer. If you find something has changed please contact us to let us know!
- During installation it is the duty of the installer to check correct operation/clearances of all components.
- If Instructions are to be printed for reference in the workshop, it is recommended that they are printed in colour, for best legibility.

PARTS LISTING

IMPORTANT: Check all parts are present before beginning work! Contact OFFROAD ANIMAL if something is missing.

Main Parts – In the Box

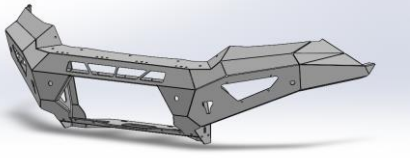
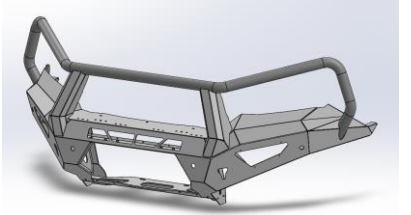
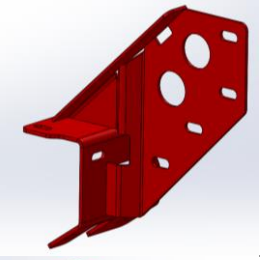
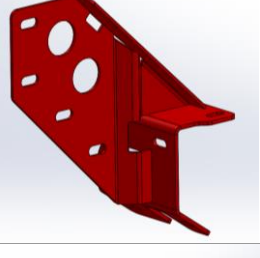
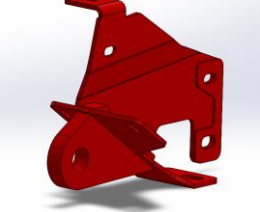
Qty	Part Number	Description	Image
1	FB-IMX-RJ-21-PR-ASM1	Isuzu MUX Predator Welded Bar Assy	
OR			
1	FB-IDM-RJ-21-TOR-ASM1	Isuzu MUX Toro Welded Bar Assy	
1	FB-IDM-RG-21-PR-ASM2R	DMAX IMPACT ASSY	
1	FB-IDM-RG-21-PR-ASM2L	ISUZU DMAX 21+ IMPACT ASSY	
1	FB-IDM-RG-21-PR-ASM3R	ISUZU DMAX 21+ TOW POINT ASSY	

1	FB-IDM-RG-21-PR-ASM3L	ISUZU DMAX 21+ TOW POINT ASSY	
1	U-0036	Isuzu DMAX 2021+ Predator Bash Plate	
1	U-0037L	Isuzu DMAX 2021+ Predator Side Underpanel	
1	U-0037R	Isuzu DMAX 2021+ Predator Side Underpanel	
1	U-0041	DMAX 21+ Supplementary Underpanel	
1	M-0014	DMax Predator Center Fairlead Mesh	
1	M-0015L	DMax Predator Side Mesh	

<p>1</p>	<p>M-0015R</p>	<p>DMax Predator Side Mesh</p>	
<p>1</p>	<p>B-0644R</p>	<p>Isuzu MUX 2021+ Fog Light Bracket</p>	
<p>1</p>	<p>B-0644L</p>	<p>Isuzu MUX 2021+ Fog Light Bracket</p>	
<p>1</p>	<p>M-0002L</p>	<p>Light Cover Mesh</p>	
<p>1</p>	<p>M-0002R</p>	<p>Light Cover Mesh</p>	
<p>1</p>	<p>B-0640</p>	<p>Isuzu MUX 2021+ Predator Center Infill Panel</p>	
<p>1</p>	<p>NPF-COM-SM-ASMO</p>	<p>Number plate flip asm Small</p>	

Small Parts – Contained in Small Parts Kit Bag

Qty	Part Number	Description
10	M10 x 30	Bolt Hex, M10X30x[1.5], GR8.8 ZP
6	M10 FLANGE NUT	Flange Nut, M10x1.5 G8.8 ZP
10	M10 Flat Washer	M10 FW
2	FB-IDM-RG-21-PR-ASM4	DMAX 21+ Tow Point Nut Plate
18	M12 FW LHD	M12 FW Large Heavy Duty
12	M12X30	Bolt Hex, M12X30x1.75, GR8.8 ZP
4	M12 FLANGE NUT	Flange Nut, M12x1.75 G8.8 ZP
6	M12 Nyloc nut	M12 NYLOC NUT
10	M8 FLAT WASHER- BLACK ZINC	M8 FW- BLACK ZINC
4	M8 X 16 BHCS BZP	SCREW, BUTTON HEAD CAP, M8X16X1.25 GR12.9 BLACK ZP
6	M8 X 20 BHCS BLACK ZINC	SCREW, BUTTON HEAD CAP, M8X20X1.25 BLACK ZP
12	M8 FLANGE NUT	Flange Nut, M8x1.25 G8.8 ZP
10	M6CN3MM	CAGE NUT M6x2.6-3.5
32	M6x16 BHCS BLACK ZINC	SCREW, BUTTON HEAD CAP, M6X16X1 GR12.9 BLACK ZP
32	M6 FLAT WASHER BLACK ZINC	M6 FW BLACK ZP
22	M6 FLANGE NUT	Flange Nut, M6x1 G8.8 ZP
2	NP-COM-M10-190-ASM0	M10 LOLLYPOP NUT PLATE 190MM LONG
8	M5 FLANGE NUT	Flange Nut, M5x0.8 G8.8 ZP
8	M5 Flat washer	M5 FW
8	M5X15 BHCS	SCREW, BUTTON HEAD CAP, M5X15X0.8 GR12.9 ZP
4	M8 FLAT WASHER	M8 FW
4	M8 X 20 HEX	Bolt Hex, M8X20x1.25, GR8.8 ZP
2	B-0508	DMAX 21+ Headlight Securing Bracket

Toro Parts – In Addition to Above

Qty	Part Number	Description
2	B-0523	Toro Antenna Bracket - 90 Degree
4	M8 X 20 BHCS BLACK ZINC	SCREW, BUTTON HEAD CAP, M8X20X1.25 BLACK ZP
4	M8 FLAT WASHER- BLACK ZINC	M8 FW- BLACK ZINC

TOOLS REQUIRED

The following tools will be required to install the product.

Hand Tools	Power Tools	Workshop Equipment
Metric Socket Set 8-19mm Socket Extension Bar Metric Spanner Set 10-19mm Torx Drivers T25-T30 Hex (Allen) Key Set 4-6mm Trim Puller Tool Flat Blade Screwdriver set Phillips Head Screwdriver set Utility Knife Side Cutters Pliers	Air Hacksaw or Angle Grinder Electric/Air Impact Driver (Optional)	Panel Stand or Soft Blanket Cable Ties Sandpaper Automotive Hose Clamp

WORKSHOP SAFETY

It is the responsibility of the installer to always complete works in a safe manner. Make sure the following safety equipment is available and precautions are observed whilst fitting this product.

<p>Hearing Protection</p> 	<p>Always wear ear protection when using power tools.</p>
<p>Eye Protection</p> 	<p>Ensure eye protection is always worn when cutting or drilling.</p>
<p>Manual Handling</p> 	<p>Do not attempt to lift bar assemblies or rock sliders on your own.</p> <p>Always use two people to lift or use mechanical lifting aid such as hydraulic lifting trolley.</p>
<p>Vehicle Support</p> 	<p>Always ensure vehicle is properly supported when working on it. Do not attempt to fit products whilst suspension work is being carried out. Do not work under a vehicle supported only by a jack.</p>

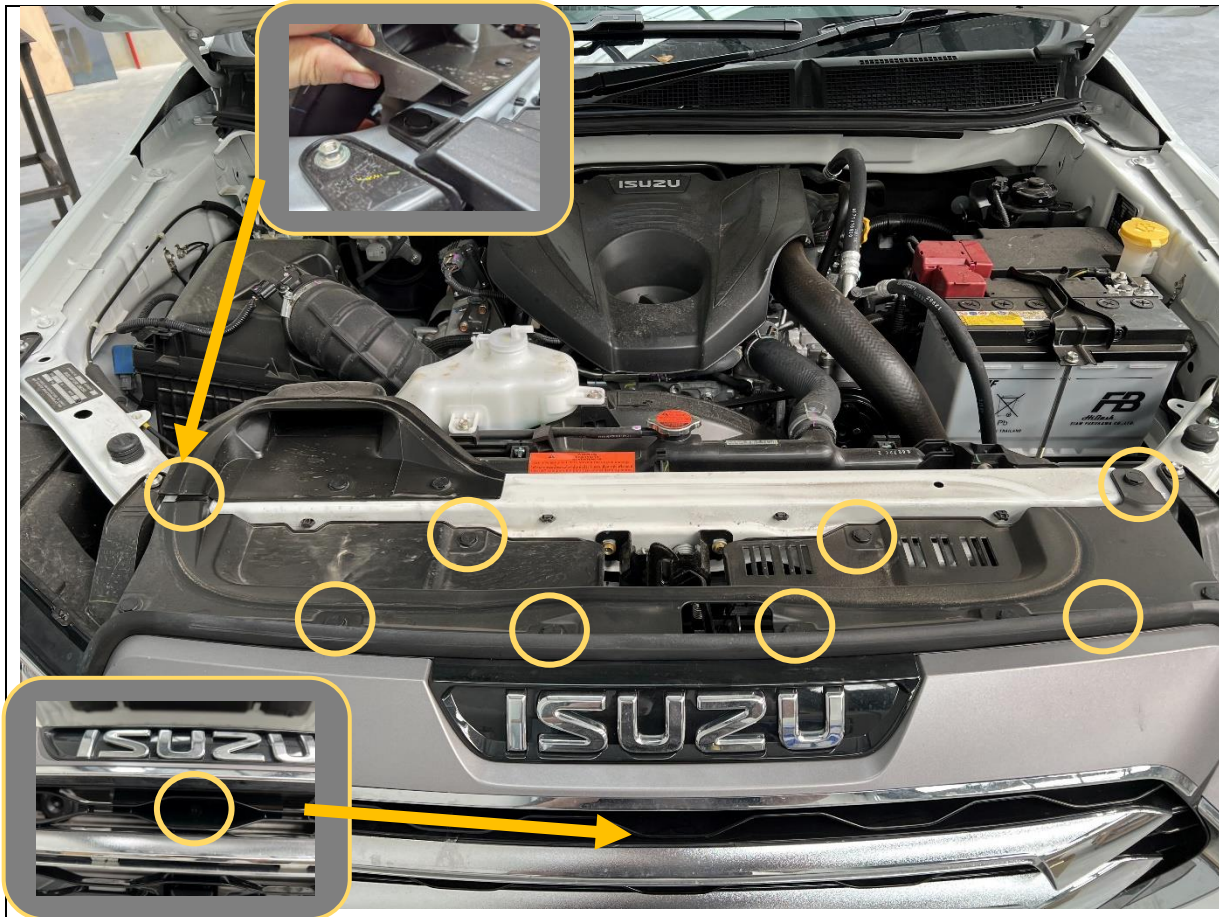

1. Open the Bonnet.
2. Remove the 4x Clips securing the top of the grille by levering up center part using small flat blade screwdriver
3. Remove phillips head screw securing bottom of grille underneath "ISUZU" badge.
4. Remove the top portion of the grille from the car

TOOLS REQUIRED
Small Flathead Screwdriver
Phillips Head screwdriver

FASTENERS
Retain Factory Clips and Screw

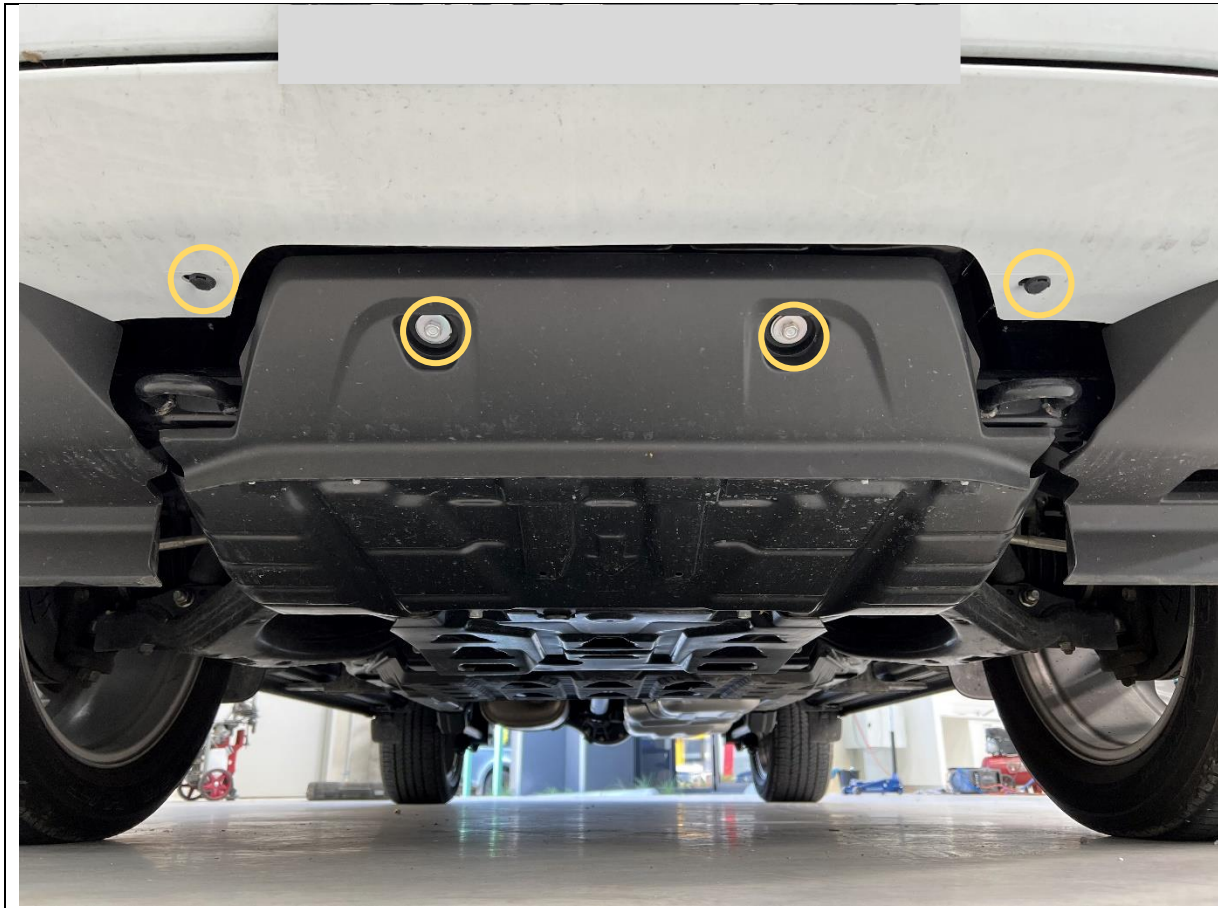

5. Remove the screws securing the plastic lower trim, using 10mm Socket / Spanner
6. Remove the clips securing the bottom edge of the bumper, using a trim tool

TOOLS REQUIRED
10mm socket / spanner
Trim tool

FASTENERS



<p>7. Remove the clips on the underside of the wheel arch by the bumper to quarter panel seam, and under the bottom of the bumper near wheel as shown.</p>	<p>TOOLS REQUIRED 10mm socket Trim Tool</p>
<p>8. Remove using same technique as other clips</p> <p>9. Remove the 10mm nut securing bottom corner of bumper.</p> <p>10. Repeat for other side of vehicle</p>	<p>FASTENERS Factory Clip and Nut</p>

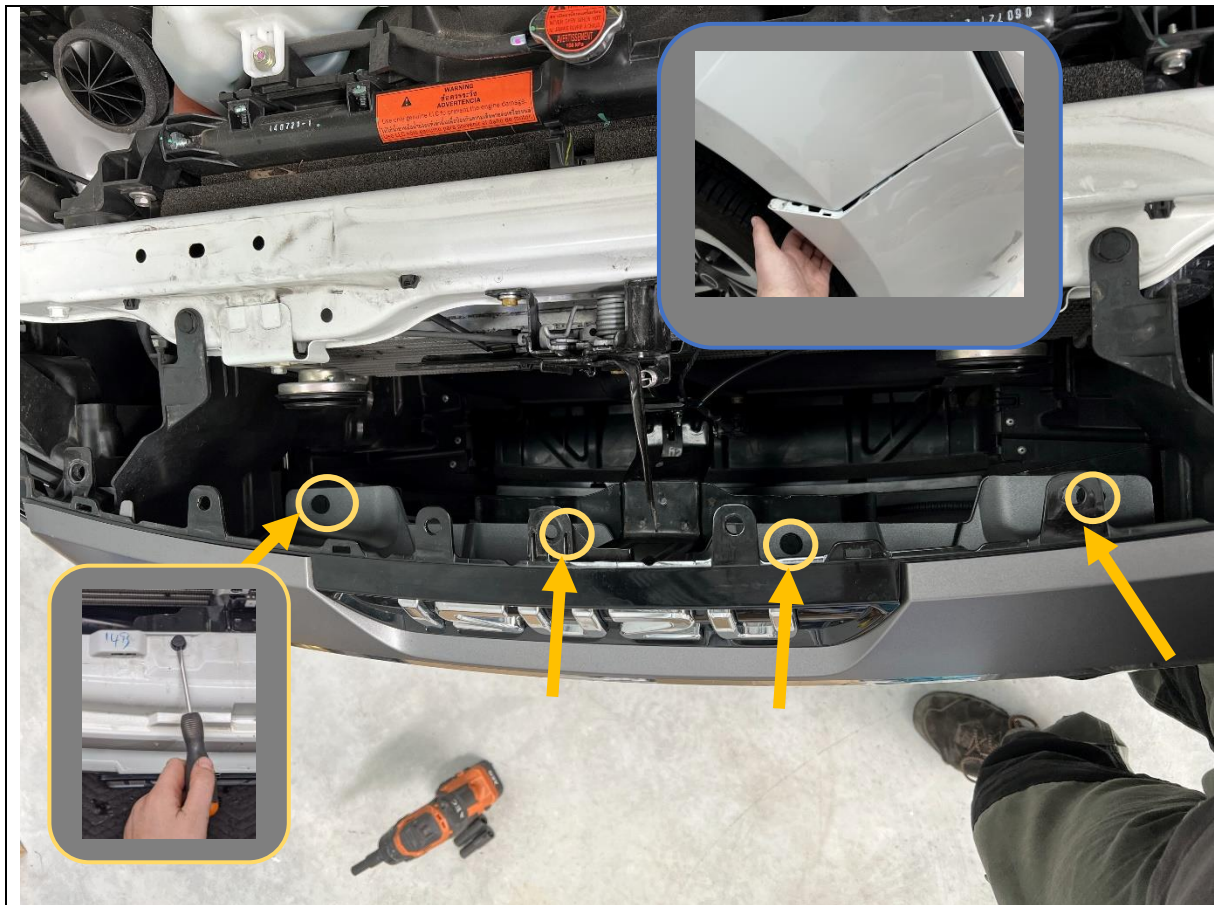

11. Remove the 4x clips securing the center of the bumper using small flat blade screwdriver to pry up the center section
12. Release the bumper clips by pulling bumper away from bottom of headlights, starting from the outside and working in.
13. When bumper is loose, reach in and disconnect the fog light wiring harness located under the left hand headlight.
14. Remove bumper from car and set aside on soft blanket or panel stand.

TOOLS REQUIRED

Small flat blade screwdriver

FASTENERS

Factory Clips

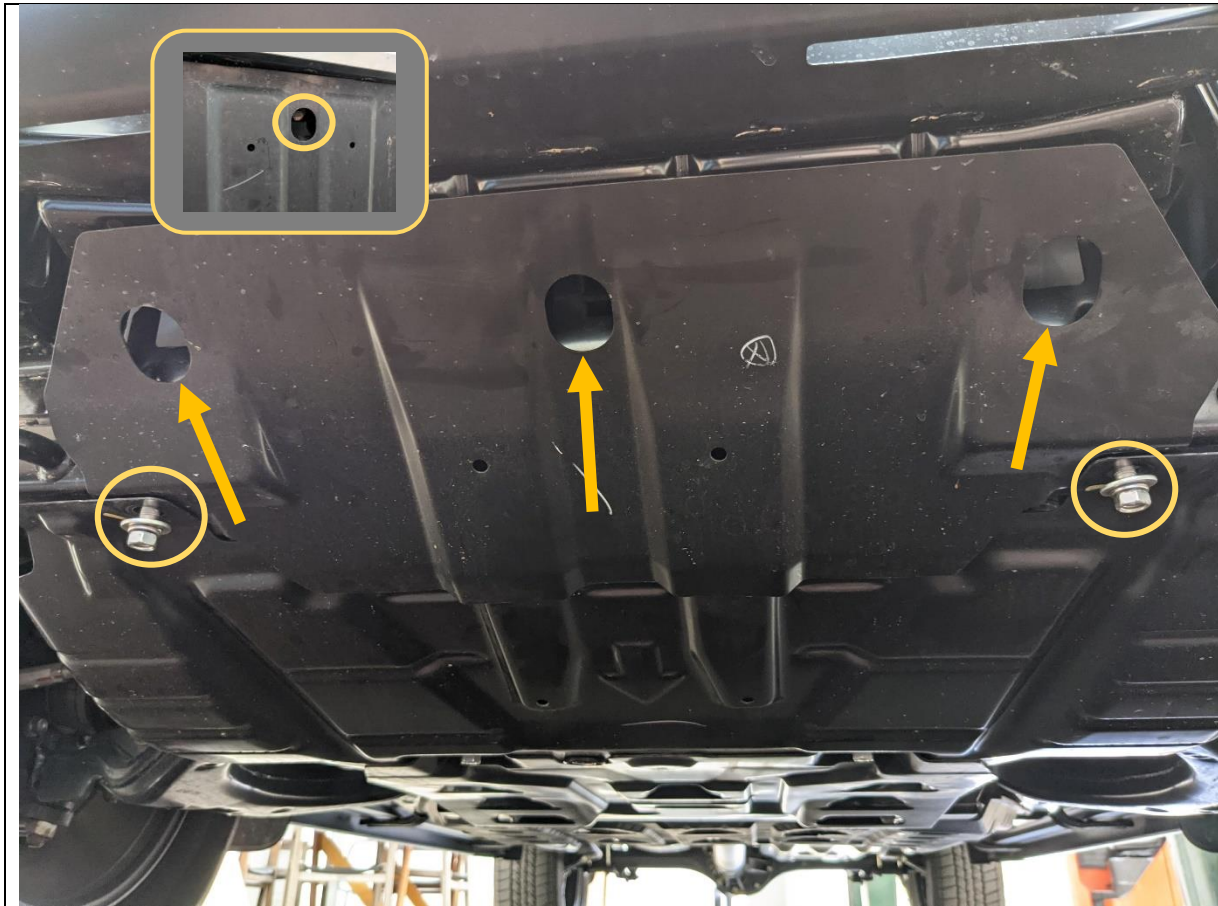

15. Remove the front skid plate by removing the 5x 14mm head bolts securing it to the chassis. Note 3x of the bolts are recessed into the skid plate, shown with arrows.

TOOLS REQUIRED

14mm socket
Short extension bar

FASTENERS

Factory 14mm head bolts.
Retain for refitment.

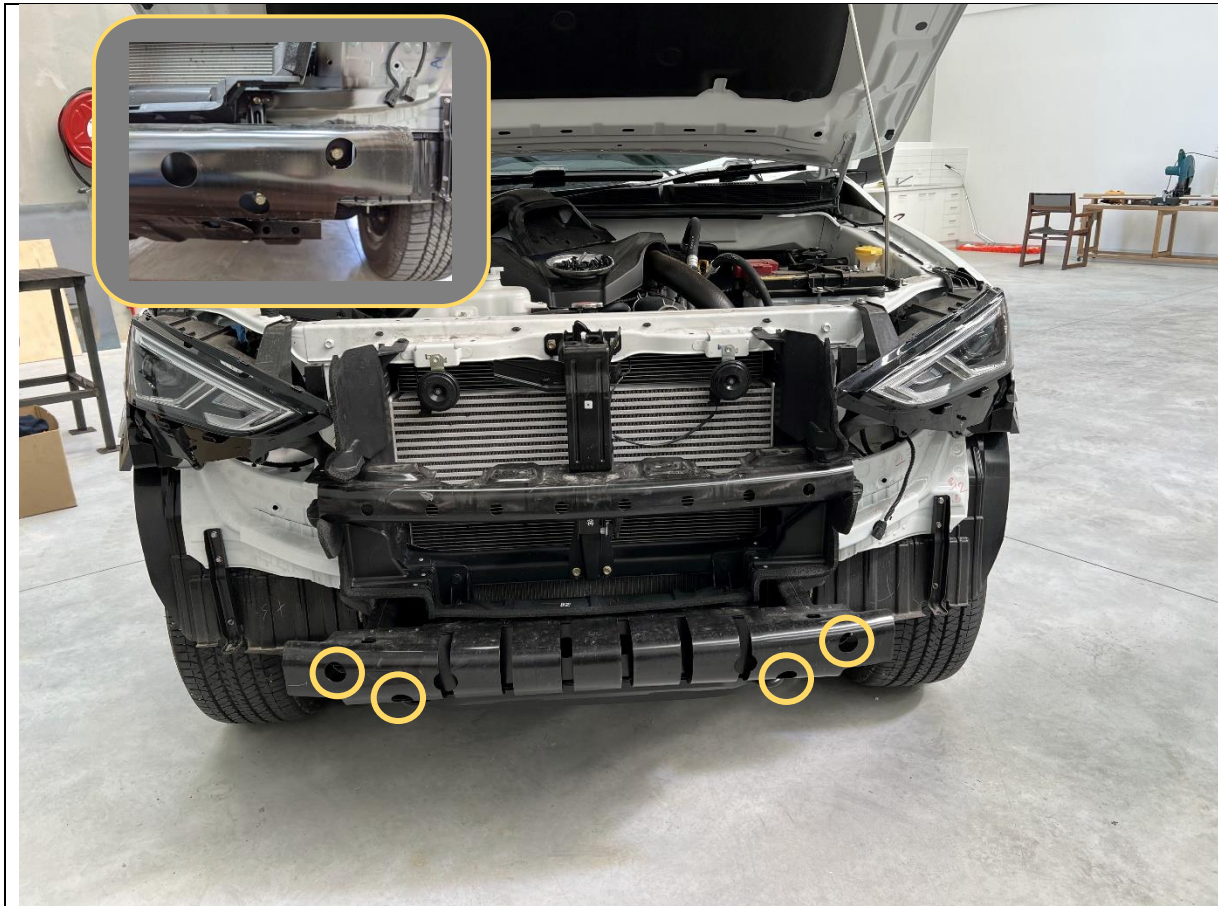

16. Remove the 4x 14mm head bolts that secure the impact beam to the chassis

17. Remove and discard the impact beam. Retain bolts for fitting of mount.

TOOLS REQUIRED

14mm socket

FASTENERS

Retain for re-fitting of mounts



- 18. Remove the 10mm bolts securing the bottom bumper supports.
- 19. Remove and discard the bumper supports

TOOLS REQUIRED

10mm socket

FASTENERS

Factory 10mm head bolts
Discard



20. Remove the 10mm and Philips head screws securing the plastic bumper supports beside the headlights. Retain the screw that secures the bumper support to the headlight.

21. Remove the bumper supports, a firm tug will be required to release the clips. Discard

22. Fit the headlight support bracket between the fender and headlight. Re-use factory bolt to secure bracket to headlight and use M6x16 flat washer and flange nut to secure to fender.

IMPORTANT – DO NOT MISS THIS STEP!

23. Complete on both sides of vehicle

TOOLS REQUIRED

Phillips head screwdriver

FASTENERS

Factory Bolt.
1x M6x16 Button Head
1x M6 Flat Washer
1x M6 Flange Nut

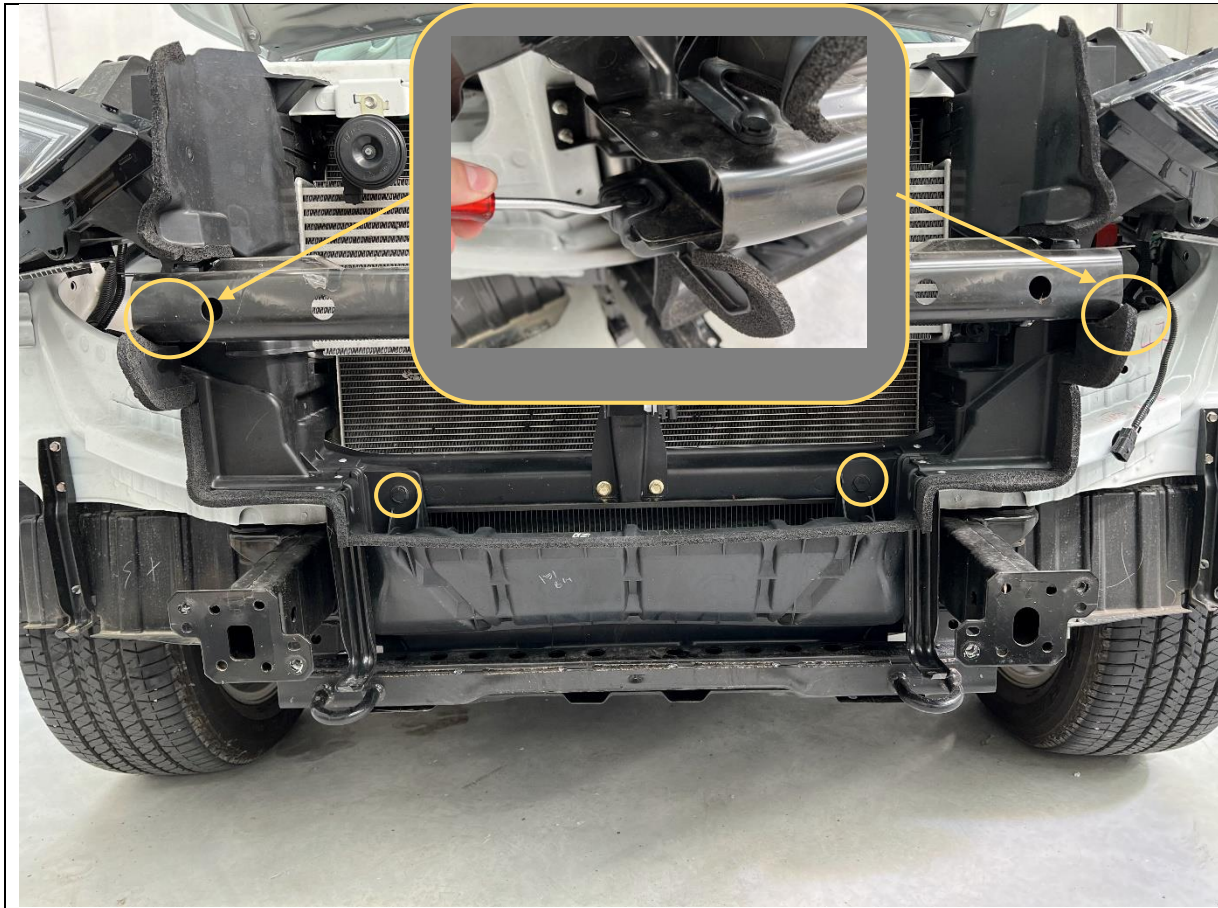

24. Remove the lower plastic air guide, by removing the clips that secure it with a trim tool.

TOOLS REQUIRED

Trim Tool





FASTENERS

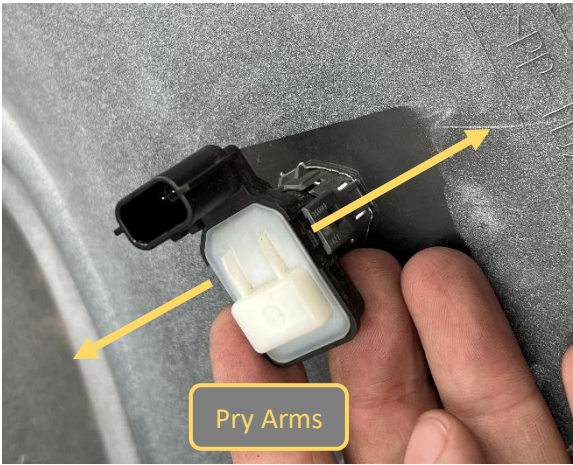

- 25. Unplug the electrical connectors from the fog light.
- 26. Remove the harness clips from the bumper using a trim tool.
- 27. Set aside harness for re-fitment to Offroad Animal Bar.
- 28. Remove fog light using Phillips head screwdriver

TOOLS REQUIRED
Trim Tools
Phillips head screwdriver

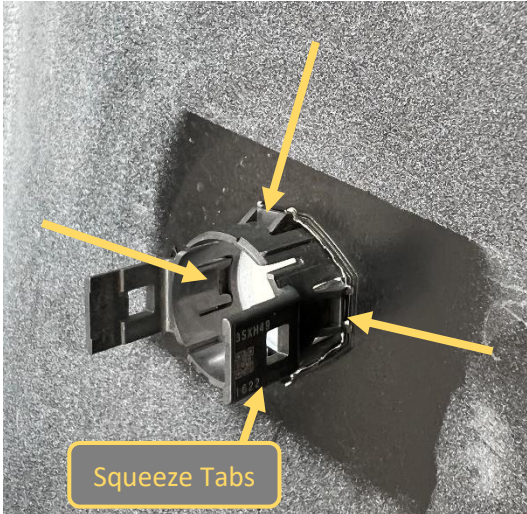
FASTENERS

 <p>Pry Arms</p>	 <p>Push Through from Front</p>
 <p>Squeeze Tabs</p>	 <p>Push Through from Back</p>
<p>29. If equipped, remove the parking sensors and parking sensor harness from the bumper.</p> <p>30. First unplug the sensor, then pry apart the securing arms whilst pushing sensor through bumper from front.</p> <p>31. To remove housing squeeze the four tabs to release whilst pushing through from back of the bumper, removing the housing from the front.</p>	<p>TOOLS REQUIRED</p> <hr/> <p>FASTENERS</p>

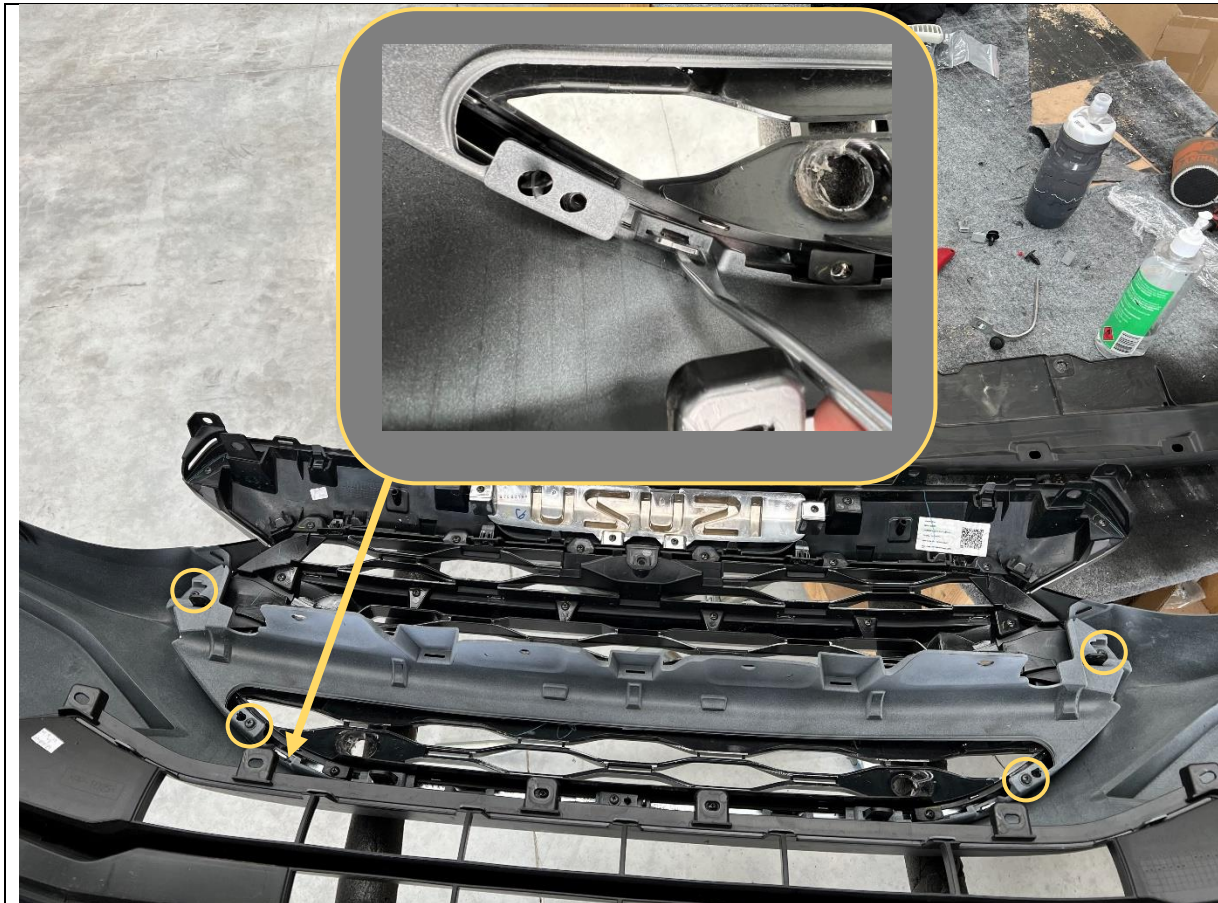

32. Separate Grille from lower portion of bumper, by first removing the Phillips head screws securing the grille and bumper together.
33. Push in the center section of locking tabs with flat screwdriver to release.

TOOLS REQUIRED
Phillips screwdriver
Trim Tool

FASTENERS

OE Philips head screws



34. Fit the fog light to the light mounting bracket supplied in the kit using supplied M6x16 button head screws, flat washers, and flange nuts.

35. Lights sit on the front side of the bracket. Take care to ensure the correct handed lights are re-fitted.

TOOLS REQUIRED

4mm Allen Key

FASTENERS

4x M6x16 Button Head Screw

4x M6Flat Washer

4x M6 Flange Nut

Per side



36. Fit the light bracket to the mesh cover panel using supplied M8x20 bolts, flat washers, and flange nuts.

TOOLS REQUIRED
13mm Spanner / Socket

FASTENERS
2x M8x20 Bolts,
2x M8 Flat washers
2x M8 Flange Nuts
Per Side

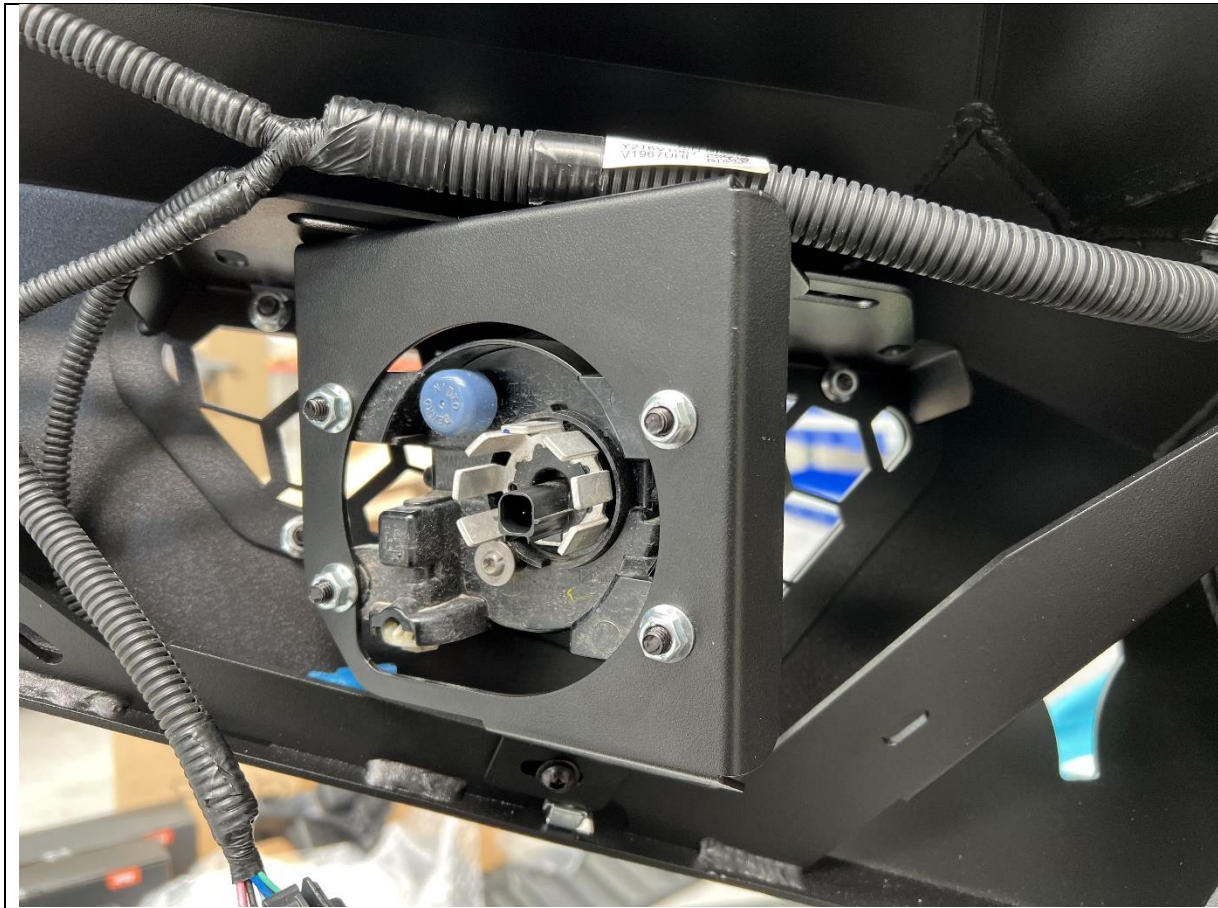

- 37. Insert the assembled light bracket / mesh panel into the wing of the bar.
- 38. Secure to wing brace with supplied M6x16 button head bolts, washers, and flange Nuts.

TOOLS REQUIRED
4mm Hex Key

FASTENERS
5x M6x16 Button Head Screw
5x M6 Flat Washer
5x M6 Flange Nut

Per side

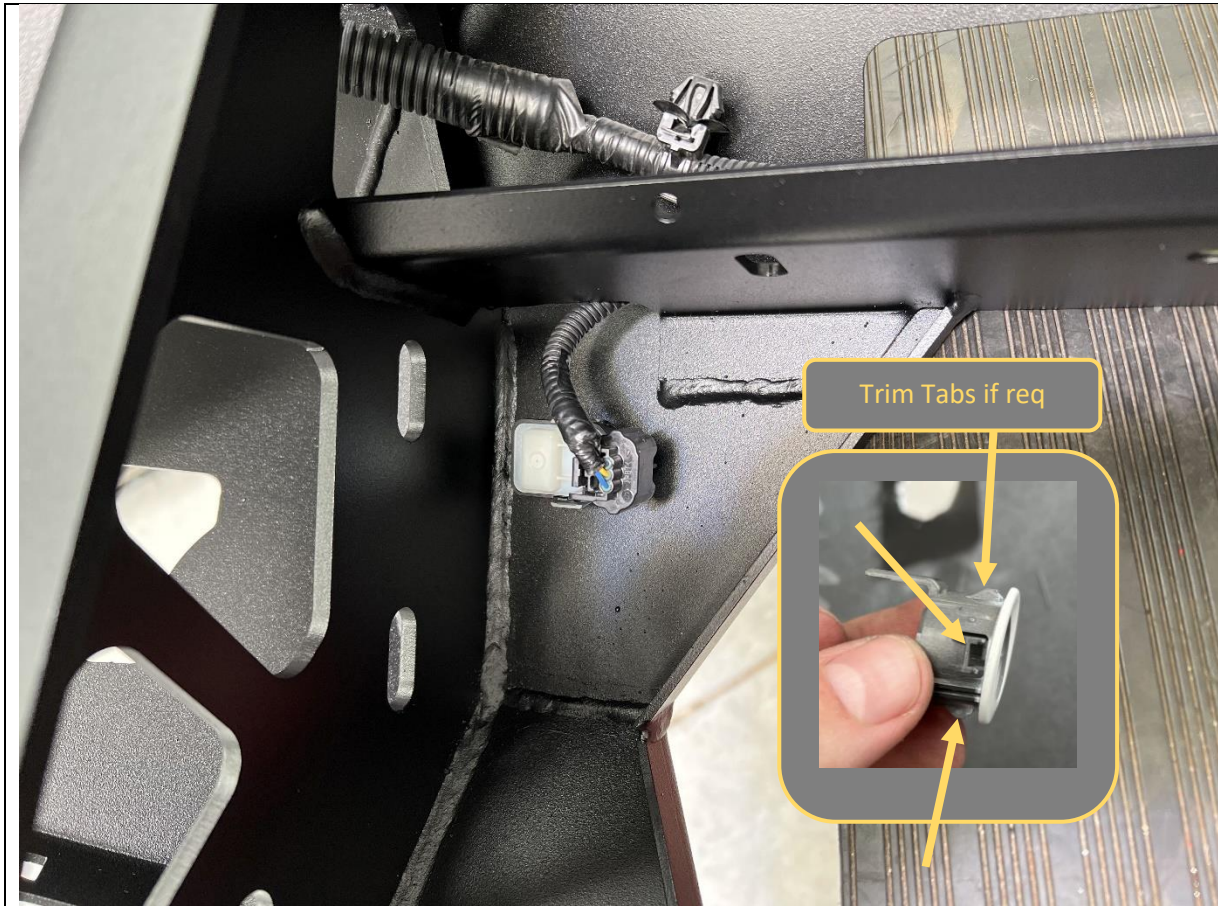

- 39. If equipped, re fit parking sensors to bar by relocating original housings to the holes on the bar.
 - 40. If sensor housings are too tight, trim the locking tabs as required to achieve a snug fit.
 - 41. Re install wiring harness to bar and plug in connectors for fog light and sensors.
- It is OK to rotate sensors to allow space for fitment of the wiring harness connectors.

TOOLS REQUIRED
Utility Knife

FASTENERS



- 42. If fitting an integrated light bar, do so now. Leave bolts loose at this stage to allow fitment of mesh panels.

- 43. The bar is designed to fit a Offroad Animal 22 inch light bar. If fitting this light bar, assemble bar with legs out, and it will line up with the slots in the center gusset. Secure with fasteners supplied with the light bar.
The bar can accommodate most other "20 inch" size light (20-22 inch long) bars

- 44. If fitting stealth top hoop or round lights do so at this stage.

- 45. Fit the center infill panel to the top pan of the bar using supplied M5 fasteners.

TOOLS REQUIRED
Refer to light bar instructions

FASTENERS
Supplied with Light bar

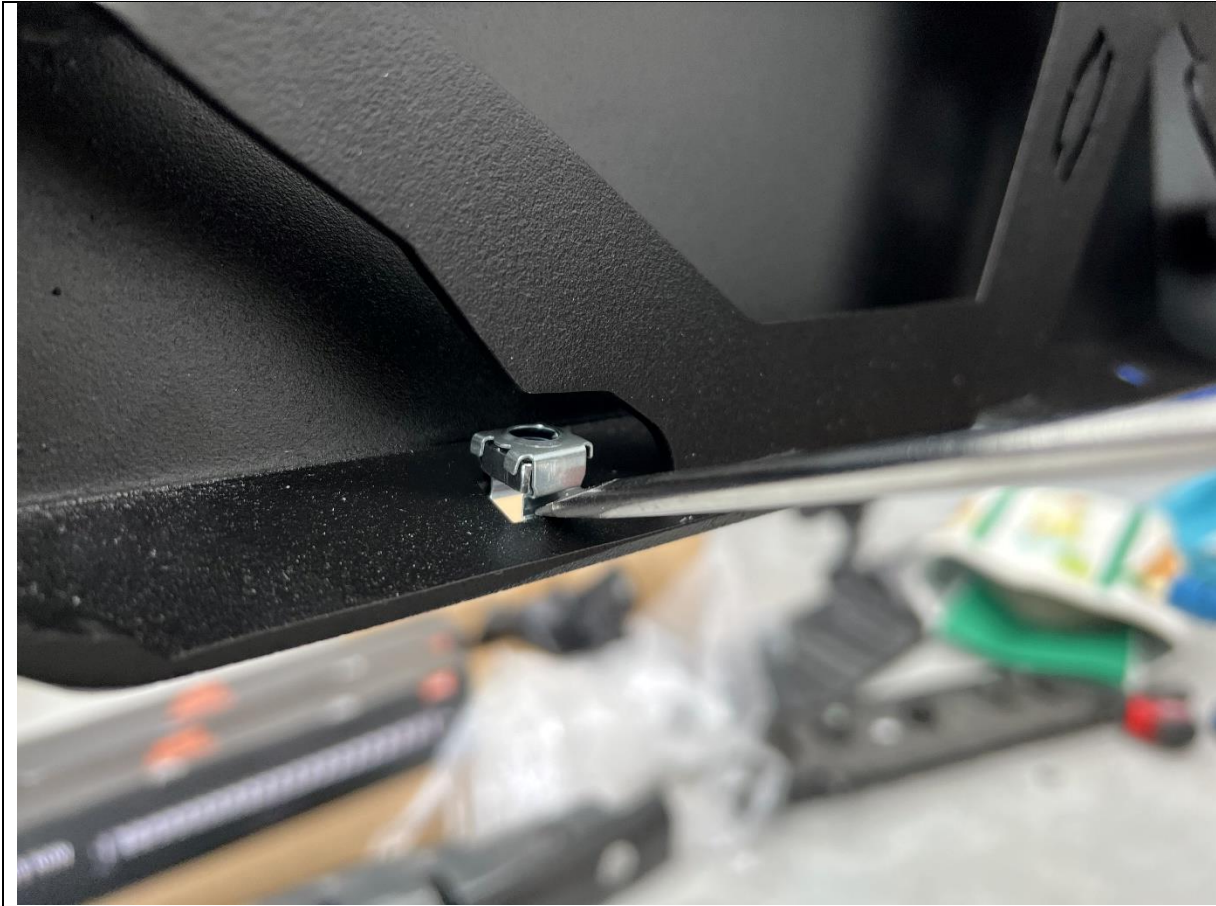

46. Fit 5x cage nuts from small parts kit to rectangular slots in bottom of wing.

Use a small flat bladed screwdriver to push the edge of the cage to engage with the slot to aid fitting.

TOOLS REQUIRED
Flat Blade Screwdriver

FASTENERS



- 47. Fit the supplied lengths of side bulb pinch weld rubber to the outermost edge of the wing on each side of the bullbar.
- 48. Use a pair of side cutters to make a notch in the pinch weld, to go around the internal bracing in the bullbar (see inset photo).
- 49. Trim to length if required.

TOOLS REQUIRED

Side cutters

FASTENERS

2x side bulb pinch weld rubber

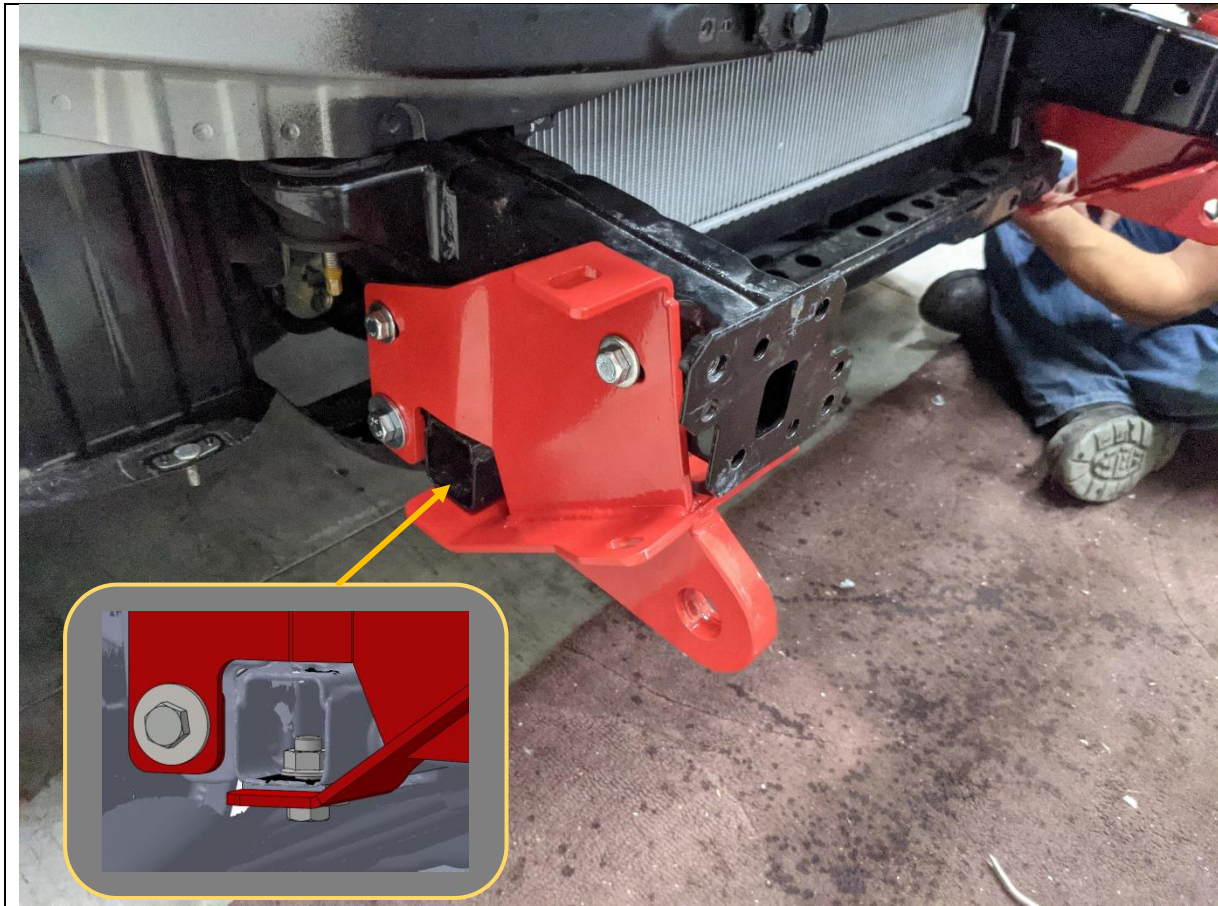

50. Fit the Tow Point to the chassis using the lollipop nut plate through the center of the chassis rail and the M10 / M12 nut plate behind the rear section of chassis. Use M12X30 bolt with flange nut inside chassis rail for bottom of mount.
51. Secure in place to threaded mounting points in chassis using original factory bolts. Leave bolts loose at this stage.

TOOLS REQUIRED

FASTENERS

- 2x M10x30
- 1x M10 Lollipop Nut Plate
- 2x M12x30 Bolt
- 1x M12 Flange Nut
- 2x M10 Flat Washer
- 2x M12 Flat Washer
- 1x M10 + M12 Nut Plate

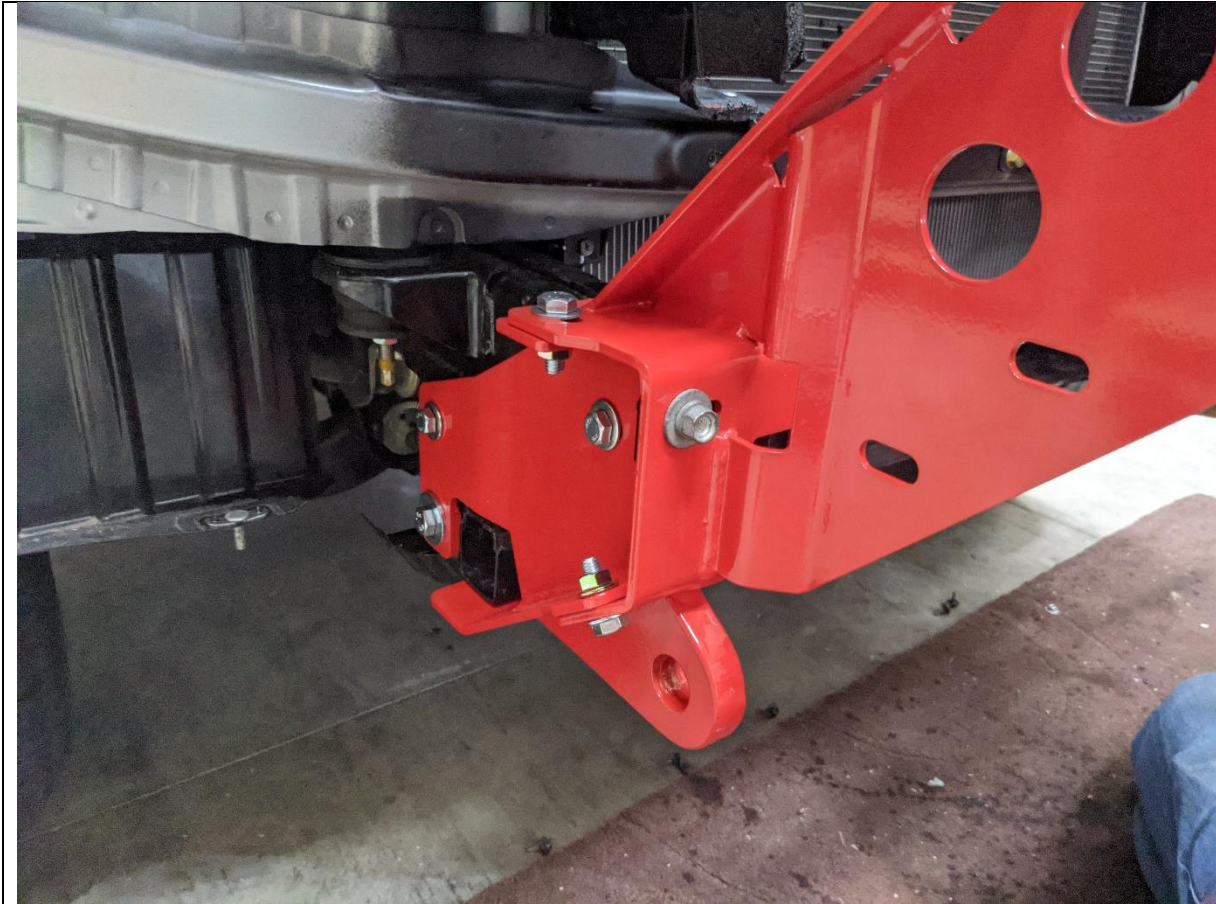

<p>52. Fit the impact assembly to the chassis using the 14mm head factory bolts retained from the crash beam.</p> <p>53. Secure to the tow point using 3x M10x30 bolts, flat washers and flange nuts as shown.</p> <p>54. Repeat for both sides of vehicle. Leave finger tight at this stage</p>	<p>TOOLS REQUIRED</p>
	<p>FASTENERS</p> <p>2x Factory M10x1.25P Bolts 3x M10x30 Hex Bolt 3x M10 Flat washer 3x M10 Flange Nut</p> <p>Per Side</p>

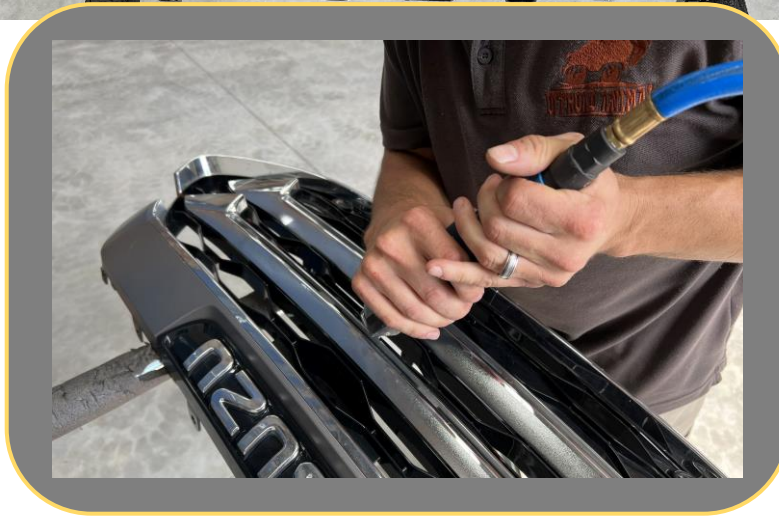
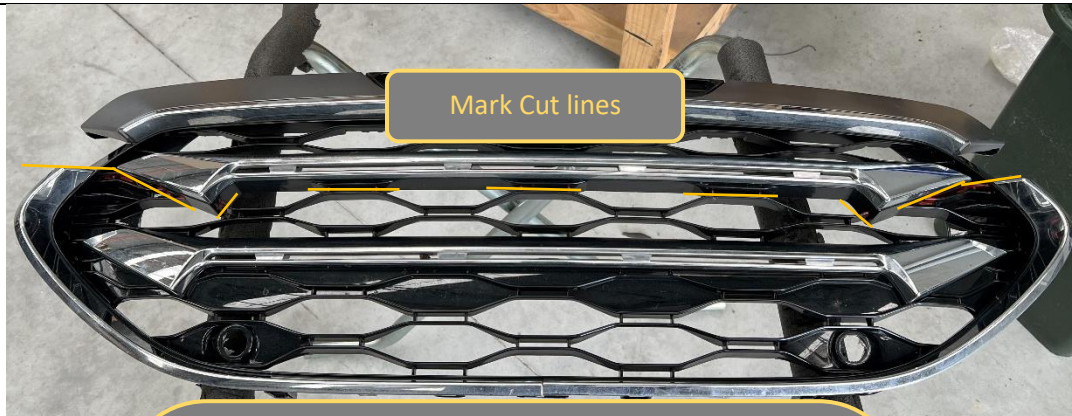

<p>55. Mark Grille Cut locations as shown above on grille using paint pen or another visible marker.</p> <p>56. Cut along marked lines using air hacksaw or angle grinder.</p>	<p>TOOLS REQUIRED</p> <p>Panel Stand Marker Air Hacksaw</p>
	<p>FASTENERS</p>



57. Re fit the grille section to the vehicle, re using the factory top panel, clips and screw.

TOOLS REQUIRED
Phillips Screwdriver

FASTENERS
Re Use Factory

<div data-bbox="662 235 949 331" data-label="Section-Header"> <p>MEASURE</p> </div> <div data-bbox="252 353 1356 638" data-label="Image"> </div>	
<div data-bbox="646 694 933 790" data-label="Section-Header"> <p>Adjust</p> </div> <div data-bbox="391 739 1173 1086" data-label="Image"> </div>	
<p>58. Measure distance between bullbar uprights with tape measure. Note down this distance</p> <p>Distance = _____</p> <p>59. Measure and adjust the distance between the mounts on the vehicle to be 2-5mm greater than the distance measured.</p> <p>60. Tighten all bolts securing impact assembly and tow point, and re check distance. Re adjust as required to achieve correct distance.</p>	<p>TOOLS REQUIRED</p> <p>13mm Socket 14mm Socket 16mm Socket</p> <hr/> <p>FASTENERS</p>



61. With assistance, either from another person or a lifting trolley, lift the bar onto the mounts on the vehicle.

TOOLS REQUIRED

Lift Trolley

FASTENERS



62. Secure bar to mount with 4x M12x30 Bolts, heavy duty washers and 3x M12 Nyloc and 1x M12 flange nut per side. Finger tight at this stage.

63. With assistance, from another person, align the bar with the edges of the vehicle. Adjust such that the clearances are neat and even side to side. When happy, tighten the bolts with the flange nut to lock the bar in position.

Acceptable range of clearances shown in image above. Ensure sufficient clearances along whole top edge of bar.

64. Once in position, tighten the M12 bolts using socket and spanner. An impact driver may be used to speed up this process. Tighten bolts, alternating left and right to avoid pulling bar to one side.

TOOLS REQUIRED
Lifting Trolley
19&18mm Socket and Spanner

FASTENERS
8x M12x40 Bolt
16x M12 Heavy Duty Large Washer
8x M12 Nyloc Nut



<p>65. If fitting a winch, do so now.</p> <p>66. The bar is designed to fit most low mount winches, in foot down configuration. WARN ZEON 10 is largest winch confirmed to fit.</p> <p>67. The control box can to be mounted on top of the winch. Winches usually come with a bracket to allow this. Refer to winch manufacturer.</p>	<p>TOOLS REQUIRED</p> <p>Refer to winch Instructions</p>
	<p>FASTENERS</p> <p>Refer to Winch instruction.</p>

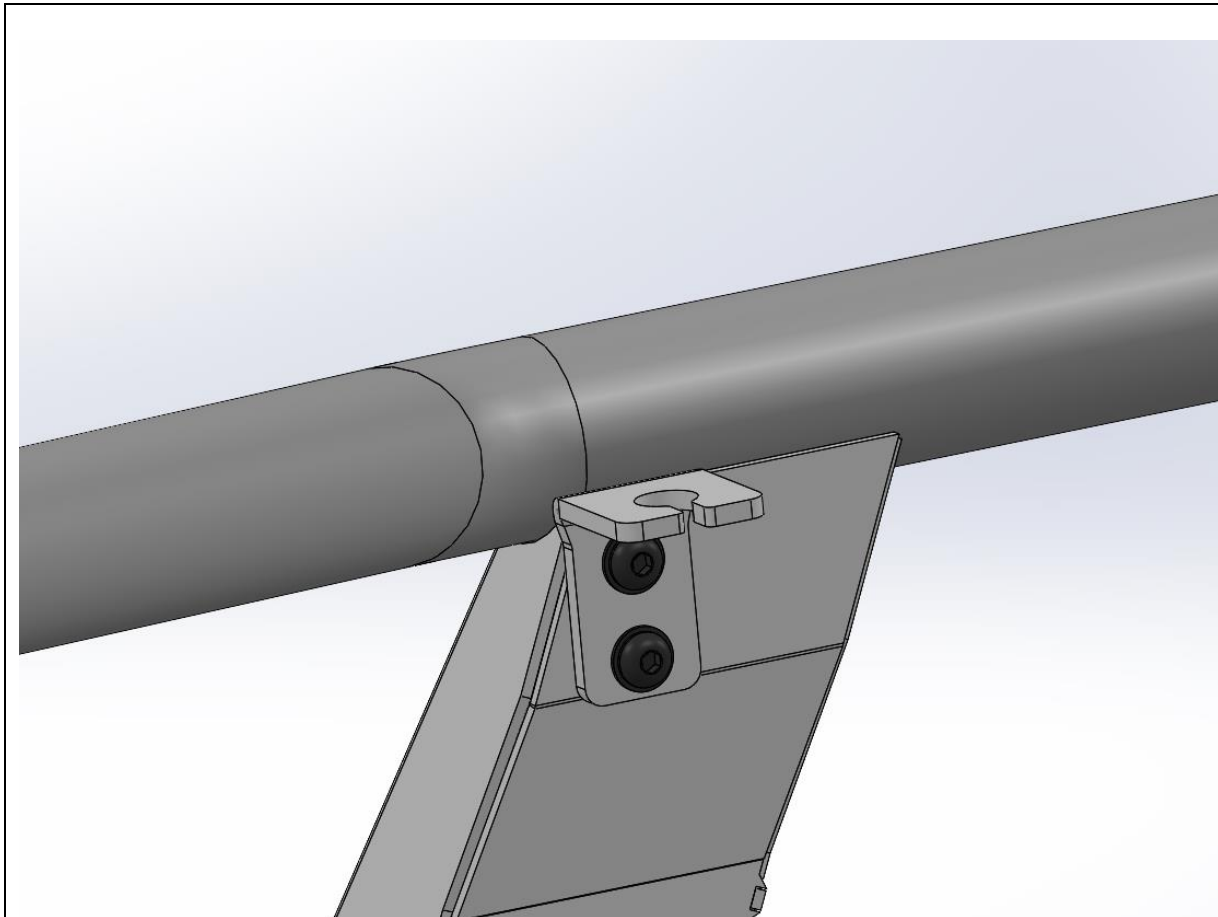

<p>68. Toro bars only. If fitting UHF antenna fit antenna brackets to the captive nuts in the back side of the uprights.</p>	<p>TOOLS REQUIRED</p> <p>5MM Allen Key</p>
<p>69. If not fitting antenna, fit the supplied M8x20 Button head bolts and flat washers in the threads to preserve them for future use. Supply the antenna brackets to the customer for future fitment.</p> <p>70. Fit antenna to antenna brackets, Refer to antenna instructions.</p>	<p>FASTENERS</p> <p>4x M8x20 Black Button Head. 4x Black M8 Washer</p>

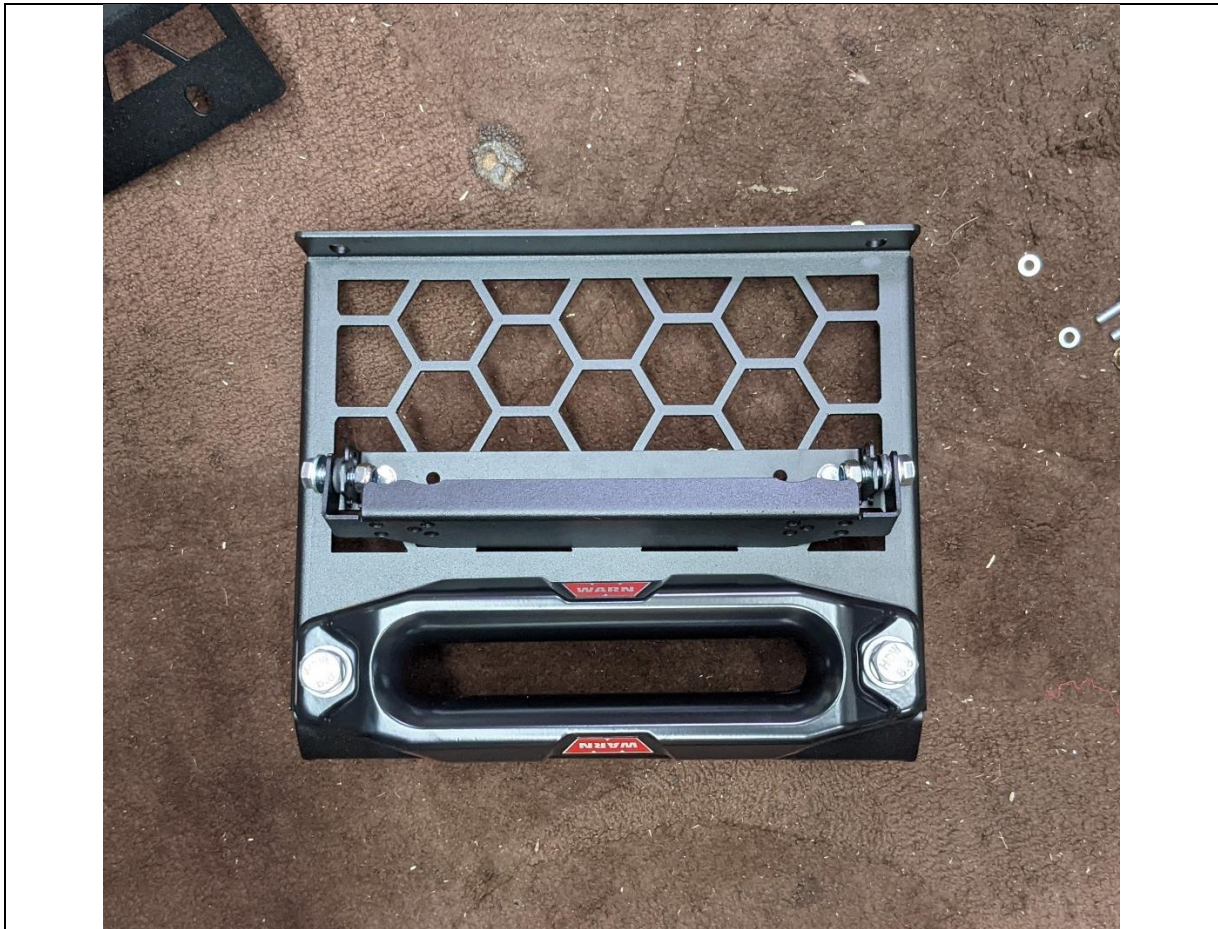

<p>71. Prepare the center mesh panel for fitment.</p> <p>72. If required, fit winch fairlead to Mesh Fairlead Mount (M-0014). Use M10 or 3/8" fasteners supplied with winch. The bar is only compatible with Hawse type fairleads.</p> <p>73. Fit number plate flip kit to fairlead mount, using fasteners supplied in kit.</p>	<p>TOOLS REQUIRED</p> <p>Depends on winch supplied fasteners</p>
	<p>FASTENERS</p>



- 74. Fit the Mesh Fairlead Mount (M-0014) to the center of the bar, using M8x16 Button head (Top), M8x20 Button Head (Bottom) M8 Flat Washers and M8 Flange Nuts.
- 75. Tighten fasteners using 13mm socket / spanner and 5mm Allen Wrench.

TOOLS REQUIRED

- 13mm Spanner
- 5mm Allen Wrench**

FASTENERS

- 2x M8x16 Button Head
- 2x M8x20 Button Head
- 4x M8 Flange Nut
- 4x M8 Flat Washer

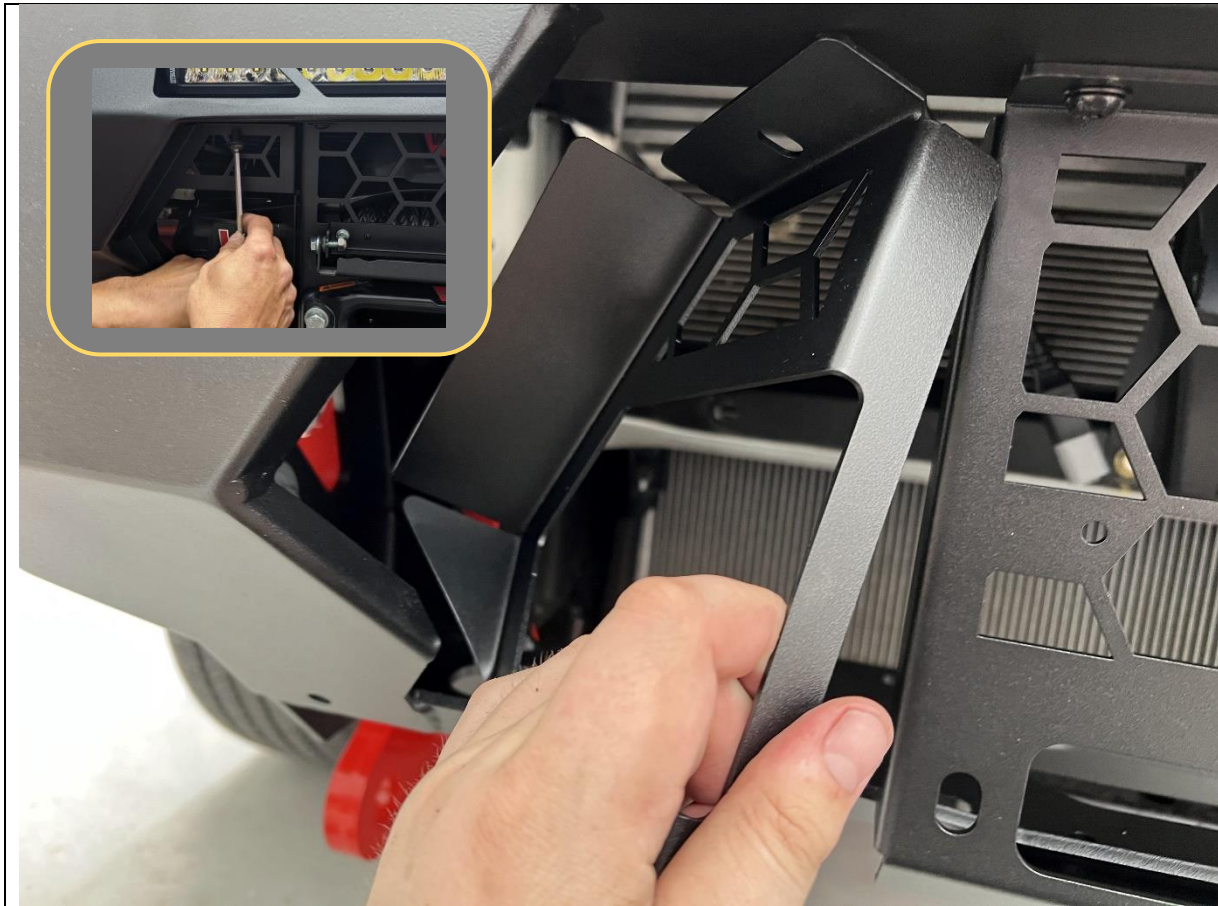

76. Fit Mesh Infill Panels (M-0008L/R). Secure with M8x16 button head bolt and M8 flat washer into the threaded insert in bar for top mount.

IMPORTANT: The flange of the infill panel should sit on the inside of the bar.

77. Don't fit any bolts to bottom holes at this stage.

78. Tighten top fasteners using 5mm Allen Wrench.

TOOLS REQUIRED
5mm Allen Wrench

FASTENERS

2x M8x16 Button Head
2x M8 Flange Nut



79. Re-connect fog light and parking sensor (if equipped) wiring connectors.

TOOLS REQUIRED

FASTENERS

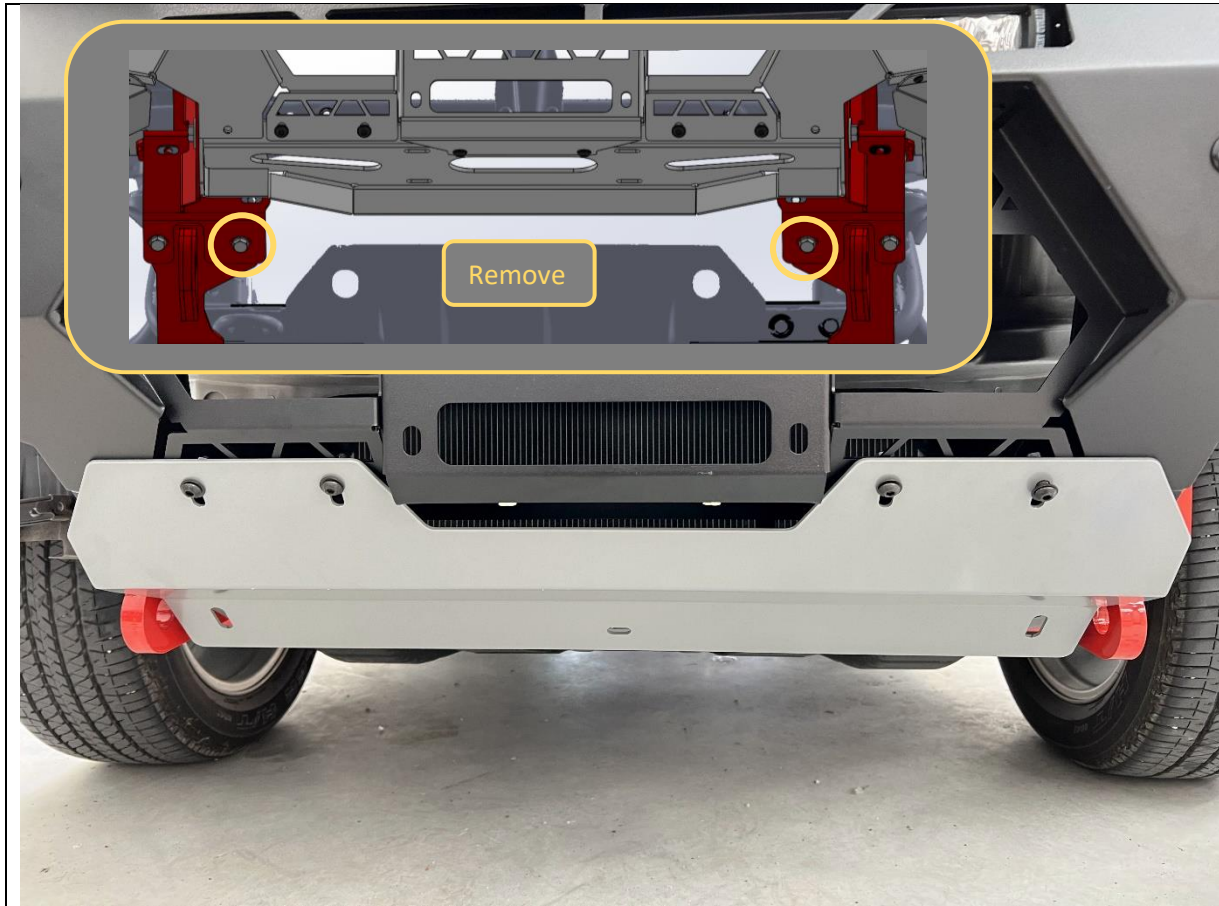

80. Before fitting bash plate, remove the M10x30 Bolt on the inside of the tow point / impact assembly joint.
81. Fit Center Bash Plate using M8x20 button head, flat washer and flange nut to front face. Ensure these fasteners pass through the side mesh panels.
82. Secure back of Center Bash Plate using M10x30 hex head, flat washers and M10 flange nut removed in previous step, through the tow point / impact assembly parts.
83. Tighten bottom fasteners using 16/17mm spanner & socket
84. Tighten front fasteners using 13mm socket / spanner and 5mm Allen Wrench. Reach through access hole in mesh panel to reach nut.
85. Re-fit factory bash plate removed earlier, using original fasteners.

TOOLS REQUIRED

- 16/17mm Spanner
- 16/17mm Socket
- 5mm Allen Key
- 13mm spanner

FASTENERS

- 4x M8x20 Button Head
- 4x M8 Flange Nut
- 4x M8 Flat Washer



86. Remove the outside top bolts from impact assembly/tow point.

87. Fit the side under panels by first sitting the bottom mount on top of the impact assembly, then inserting the 5x M6x16 bolts into the cage nuts fitted earlier

88. Tighten with 4mm Allen wrench

89. Secure bottom of side under panel to mount using bolt removed from joint earlier.

90. Tighten with 16/17mm spanner / socket

TOOLS REQUIRED
16/17mm Spanner
5mm Allen Wrench
4mm Allen Wrench

FASTENERS
10x M6x16 Button Head
10x M6 Flat Washer



91. Mark cut location 20mm lower than the intersection of the wheel arch liner and edge of the side under panels. Once marked remove under panel
92. Using a sharp utility knife, cut back the plastic inner wheel arch liner along line marked before.
93. Tuck the wheel arch liner behind the flanges on the under panel.
94. Repeat for both sides of vehicle.

TOOLS REQUIRED
Utility Knife
Paint pen / Marker

FASTENERS



- 95. Re-check that all fasteners are tight.
- 96. Re-tit number plate to number plate flip.
- 97. You're done. Hit the tracks and enjoy your newly protected M-UX!

TOOLS REQUIRED

FASTENERS