



Toyota Landcruiser 300 Series MY2022+ Predator & Toro Front Bar Fitting Instruction

IMPORTANT! – READ BEFORE INSTALLATION

- When installed in accordance with these instructions, the front protection bar does not affect the operation of the vehicles SRS airbags.
- This product must be installed exactly as per these instructions using only hardware supplied.
- Take a few moments to read instructions thoroughly before beginning work.
- In the event of damage to any bar component please contact OFFROAD ANIMAL to arrange repair/replacement of components.
- Do not use this product for any vehicle make or model other than that specified on these instructions.
- Do not remove labels from this product.
- This product and its fixings must not be modified in any way unless stated in these fitting instructions.
- The installation of this product is recommended for trained personnel.
- These instructions are correct at time of publication. OFFROAD ANIMAL cannot be held responsible for the impact of any changes subsequently made by the vehicle manufacturer. If you find something has changed please contact us to let us know!
- During installation it is the duty of the installer to check correct operation/clearances of all components.
- If Instructions are to be printed for reference in the workshop, it is recommended that they are printed in colour, for best legibility.

PARTS LISTING

IMPORTANT: Check all parts are present before beginning work! Contact OFFROAD ANIMAL if something is missing.

Main Parts – In the Box

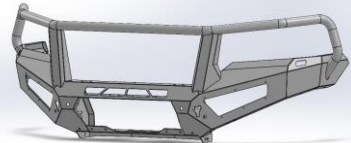
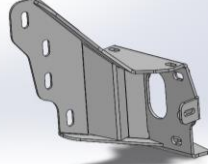
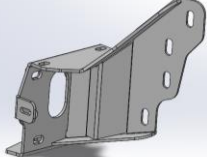
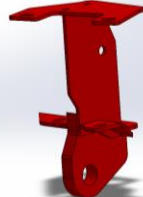
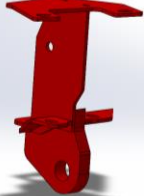
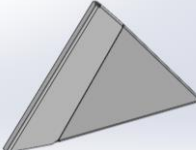
Qty	Part Number	Description	Image
1	FB-TLC-300-22-PR-ASM1	Toyota LC300 Predator Bar Weldment	
Or			
1	FB-TLC-300-22-PR-ASM1	Toyota LC300 Toro Bar Weldment	
1	FB-TLC-300-22-PR-ASM2L	Toyota LC300 Impact Assy	
1	FB-TLC-300-22-PR-ASM3L	Toyota LC300 Impact Assy	
1	FB-TPR-150-18-PR-ASM3L	Toyota LC300 Predator - Tow Assy	
1	FB-TPR-150-18-PR-ASM3R	Toyota LC300 Predator - Tow Assy	
1	B-0667L	Toyota LC300 Predator - Headlight Infill Panel	

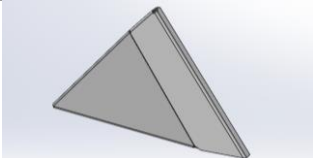
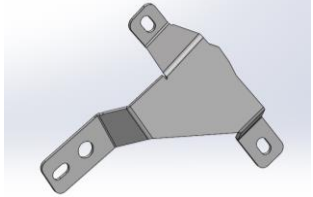
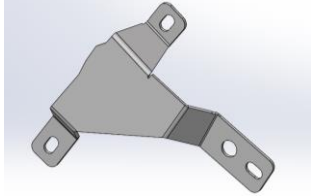
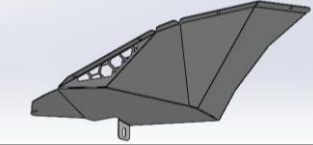
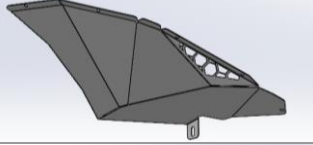
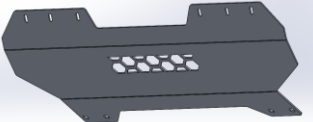
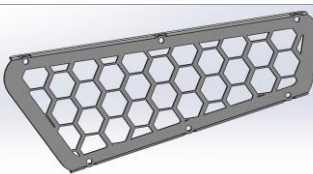
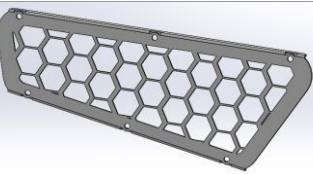
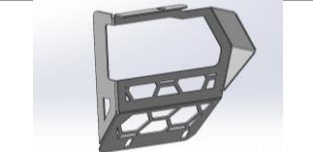
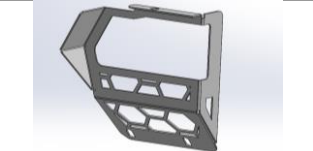

1	B-0667R	Toyota LC300 Predator - Headlight Infill Panel	
1	B-0680L	Toyota LC300 Predator - Headlight Infill Panel Mount	
1	B-0680R	Toyota LC300 Predator - Headlight Infill Panel Mount	
1	U-0047L	Toyota LC300 Predator - Side Underpanel	
1	U-0047R	Toyota LC300 Predator - Side Underpanel	
1	U-0046	Toyota LC300 Predator - Centre Underpanel	
1	M-0026L	Toyota LC300 Predator - Fog Light / Intercooler Mesh Panel	
1	M-0026R	Toyota LC300 Predator - Fog Light / Intercooler Mesh Panel	
1	M-0025L	Toyota LC300 Predator - Side Mesh Panel	
1	M-0025R	Toyota LC300 Predator - Side Mesh Panel	

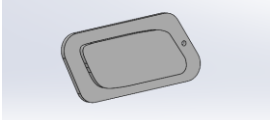

1	M-0024	Toyota LC300 Predator - Centre Fairlead Mesh Panel	
1	B-0679L	Toyota LC300 - Fog Light Bracket	
1	B-0679R	Toyota LC300 - Fog Light Bracket	
1	B-0666	Toyota LC300 Predator - Pan Brace	
1	B-0668	Toyota LC300 Predator - Number Plate Bracket	
1	FB-TLC-300-22-PR-ASM4L	LC300 Front Headlight Washer Plug Assy	
1	FB-TLC-300-22-PR-ASM4R	LC300 Front Headlight Washer Plug Assy	



Predator Small Parts – Contained in Small Parts Kit Bag

QTY.	PART NO.	DESCRIPTION
45	M6 FLAT WASHER BLACK ZINC	M6 FW BLACK ZP
38	M6 FLANGE NUT	Flange Nut, M6x1 G8.8 ZP
45	M6x16 BHCS BLACK ZINC	SCREW, BUTTON HEAD CAP, M6X16X1 GR12.9 BLACK ZP
6	M8 X 30 BHCS BLACK ZINC	SCREW, BUTTON HEAD CAP, M8X30X1.25 BLACK ZP
10	M8 FLAT WASHER- BLACK ZINC	M8 FW- BLACK ZINC
4	M8 X 16 BHCS BZP	SCREW, BUTTON HEAD CAP, M8X16X1.25 GR12.9 BLACK ZP
4	M8 X 20 HEX	Bolt Hex, M8X20x1.25, GR8.8 ZP
8	M8 FLAT WASHER	M8 FW
16	M12X30	Bolt Hex, M12X30x1.75, GR8.8 ZP
12	M12 FLANGE NUT	Flange Nut, M12x1.75 G8.8 ZP
2	M12 Nyloc nut	M12 NYLOC NUT
12	M12 FW LHD	M12 FW Large Heavy Duty
4	M10 x 25	Bolt Hex, M10X25x[1.5], GR8.8 ZP
12	M10 FW LHD	WASHER, FLAT M10X28.5X2.5
8	M10 FLANGE NUT	Flange Nut, M10x1.5 G8.8 ZP
2	M8 NYW	Washer, M8, Nylon
6	M12 FLAT WASHER	M12 FW
4	M10 x 30	Bolt Hex, M10X30x[1.5], GR8.8 ZP
4	M10 Flat Washer	M10 FW
2	NP-COM-M12-300- ASM0	M12 NUT PLATE 300MM STEM
10	M6CN3MM	CAGE NUT M6x2.6-3.5
3	M6x12 BHCS	SCREW, BUTTON HEAD CAP, M6X12X1 GR12.9 ZP
3	M6 FLAT WASHER	M6 FW
2	M8 FLANGE NUT	Flange Nut, M8x1.25 G8.8 ZP
2	M8 X 25 HEX	Bolt Hex, M8X25x1.25, GR8.8 ZP
2	M8 NYLOC	NYLOC SELF LOCKING NUT, ST STL A2 ISO

Toro Small Parts – In addition to Above

QTY.	PART NO.	DESCRIPTION
1	B-0678L	Toyota LC300 Toro- Antenna Bracket
1	B-0678R	Toyota LC300 Toro- Antenna Bracket
6	M8 FLAT WASHER- BLACK ZINC	Flange Nut, M6x1 G8.8 ZP
6	M8x20 BHCS BLACK ZINC	SCREW, BUTTON HEAD CAP, M6X16X1 GR12.9 BLACK ZP



TOOLS REQUIRED

The following tools will be required to install the product.

Hand Tools	Power Tools	Workshop Supplies
Metric Socket Set 8-19mm Socket Extension Bar Metric Spanner Set 10-19mm Hex (Allen) Key Set 4-6mm Trim Puller Tool Flat Blade Screwdriver set Phillips Head Screwdriver set Utility Knife Side Cutters Pliers	Electric Drill 6mm Drill Bit Electric/Air Impact Driver (Optional)	Double Sided Adhesive Tape (3M VHB or Equivalent) Panel Stand or Soft Blanket Cable Ties Masking Tape Black Automotive paint Scotch Brite or Fine Sandpaper Automotive Sealant/Adhesive (Sikaflex 227 or Equiv) Bucket Hose Clamp

WORKSHOP SAFETY

It is the responsibility of the installer to always complete works in a safe manner. Make sure the following safety equipment is available and precautions are observed whilst fitting this product.

<p>Hearing Protection</p> 	<p>Always wear ear protection when using power tools.</p>
<p>Eye Protection</p> 	<p>Ensure eye protection is always worn when cutting or drilling.</p>
<p>Manual Handling</p> 	<p>Do not attempt to lift bar assemblies or rock sliders on your own.</p> <p>Always use two people to lift or use mechanical Lifting aid such as hydraulic lifting trolley.</p>
<p>Vehicle Support</p> 	<p>Always ensure vehicle is properly supported when working on it. Do not attempt to fit products whilst suspension work is being carried out. Do not work under a vehicle supported only by a jack.</p>



1. Open the Bonnet,
2. Remove clips securing the top radiator cowling. Press down on the center button of clip to unlock, then remove clip with trim tool.
3. Retain all clips for reassembly

TOOLS REQUIRED

Trim Tool

FASTENERS

Retain Factory



4. Remove the 3x Bolts securing top of grille to body using 10mm socket.
5. Disconnect the Electrical harness connectors (LHS) and Headlamp washer fluid connector (RHS, VX models and above)

TOOLS REQUIRED

10mm socket.

FASTENERS

Retain Factory

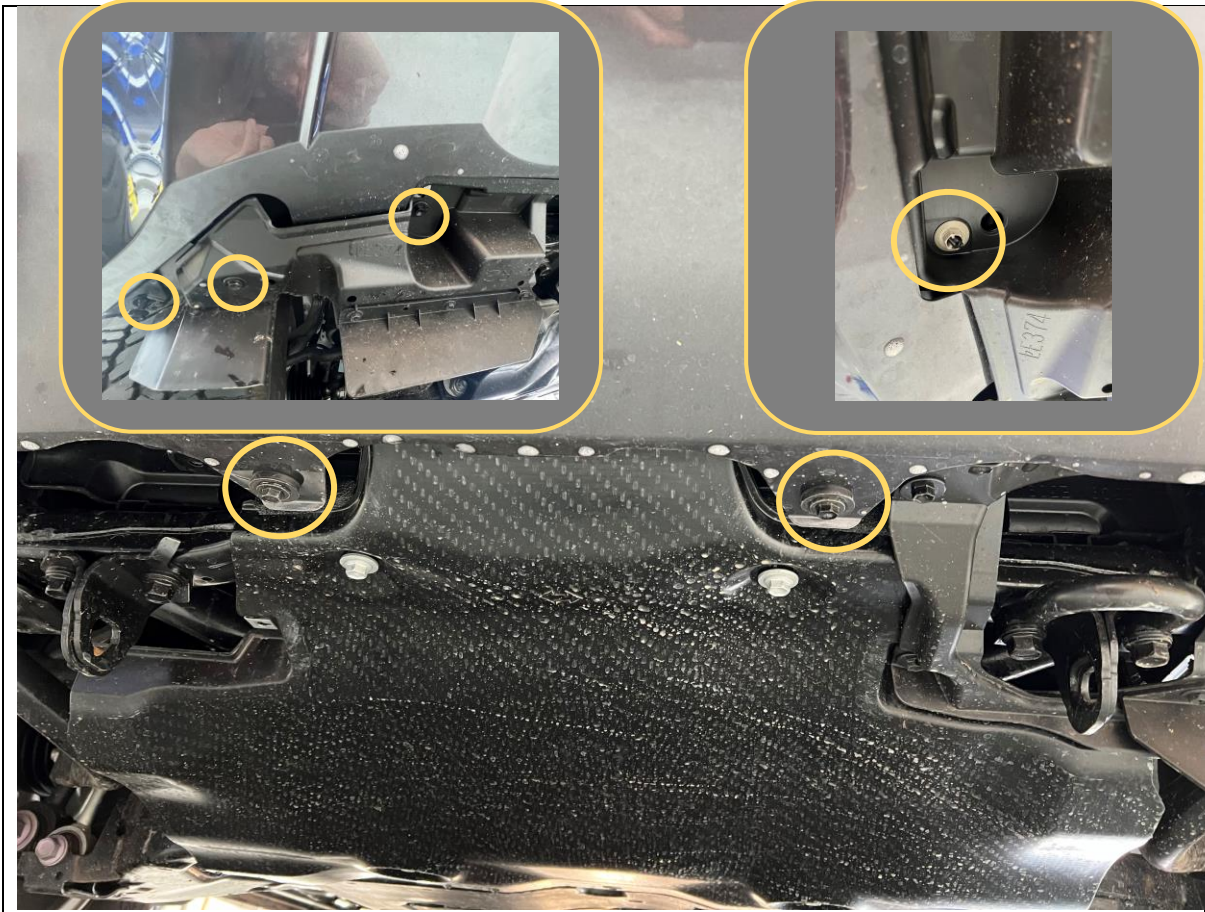

6. Remove the 10mm head screws securing the bumper to the lower crossmember.
7. Remove the plastic nuts that also secure the bumper.

TOOLS REQUIRED

10mm socket
Trim Tool

FASTENERS

Factory Bolts (Discard)

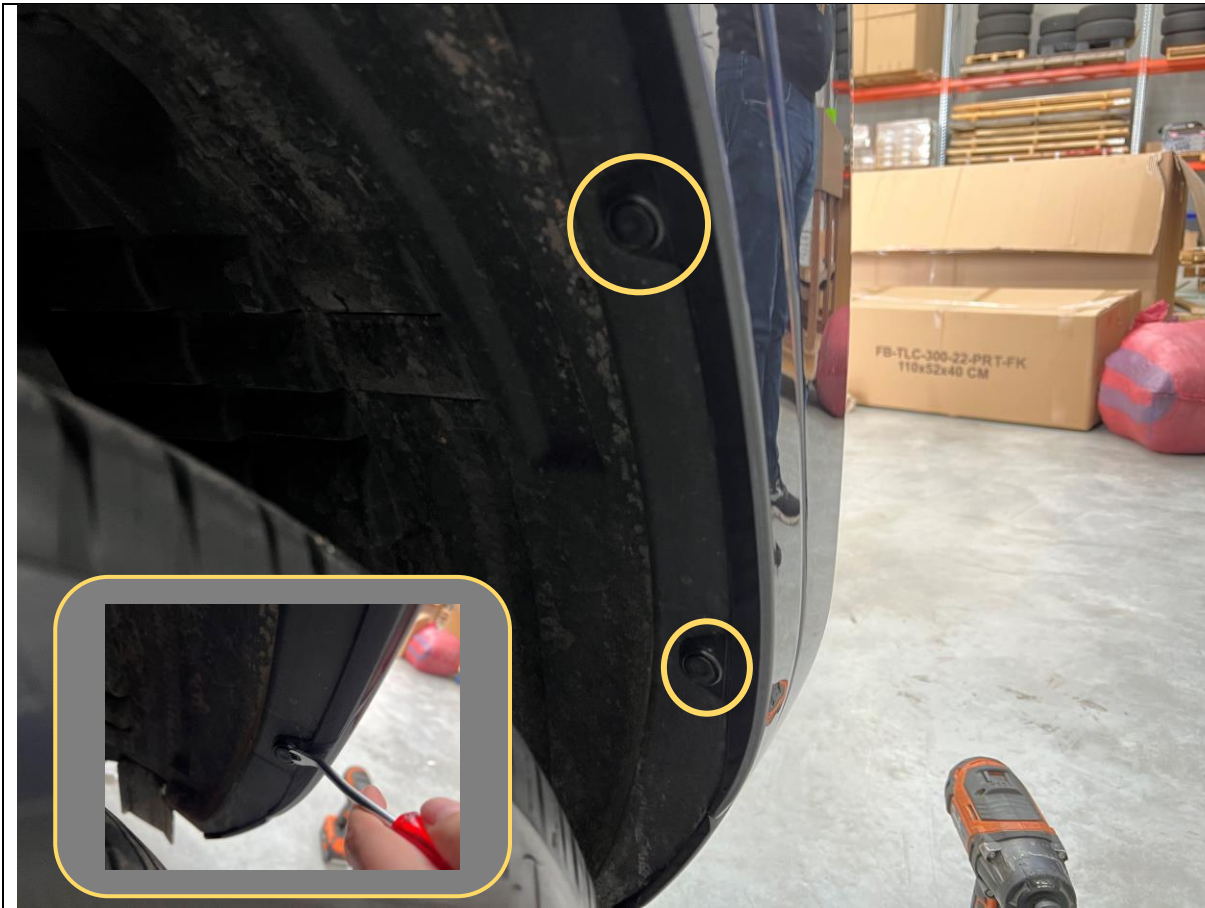

8. Remove clips securing wheel arch flare and inner guard liner by prying up center part of clip using a trim tool.

9. There are several clips securing each flare.

TOOLS REQUIRED

Trim Tool

FASTENERS



10. -In addition to the clips there are also button head screws. Remove these using 4mm Hex key.

11. Remove all fasteners securing the flare and inner arch liner. Complete on both sides of the vehicles

TOOLS REQUIRED

4mm Hex Key

FASTENERS



12. Before removal of the flare, place masking tape in line with the bumper to guard panel line, this will assist in trimming flare later.
13. Progressively release the clips securing the wheel arch flare to the bumper and front guard. Start from the bottom corner of the flare towards the front of the vehicle.
14. Use trim tool as required to assist releasing the clips

TOOLS REQUIRED

Trim Tool

FASTENERS



15. Remove the clip securing the Front bumper skin to the body, using trim tool.
16. Complete on both sides of the vehicle.

TOOLS REQUIRED

Trim Tool

FASTENERS



17. Starting from the wheel arch, carefully pull the bumper away from the body of the vehicle to release the clips.
18. Remove the bumper and set aside on a soft blanket or panel stand

TOOLS REQUIRED

FASTENERS



19. Disconnect the Fog light harness from the fog light.
20. Remove the fog lights from the bumper, by removing the three Philips head screws.
21. Remove both the electrical harness, and headlight washer pipes from the bottom half of the bar (not grille), by prying out the clips using trim tool.
22. Complete on both sides of bumper.

TOOLS REQUIRED

Phillips head Screwdriver
Trim tool

FASTENERS

Discard Factory Screws

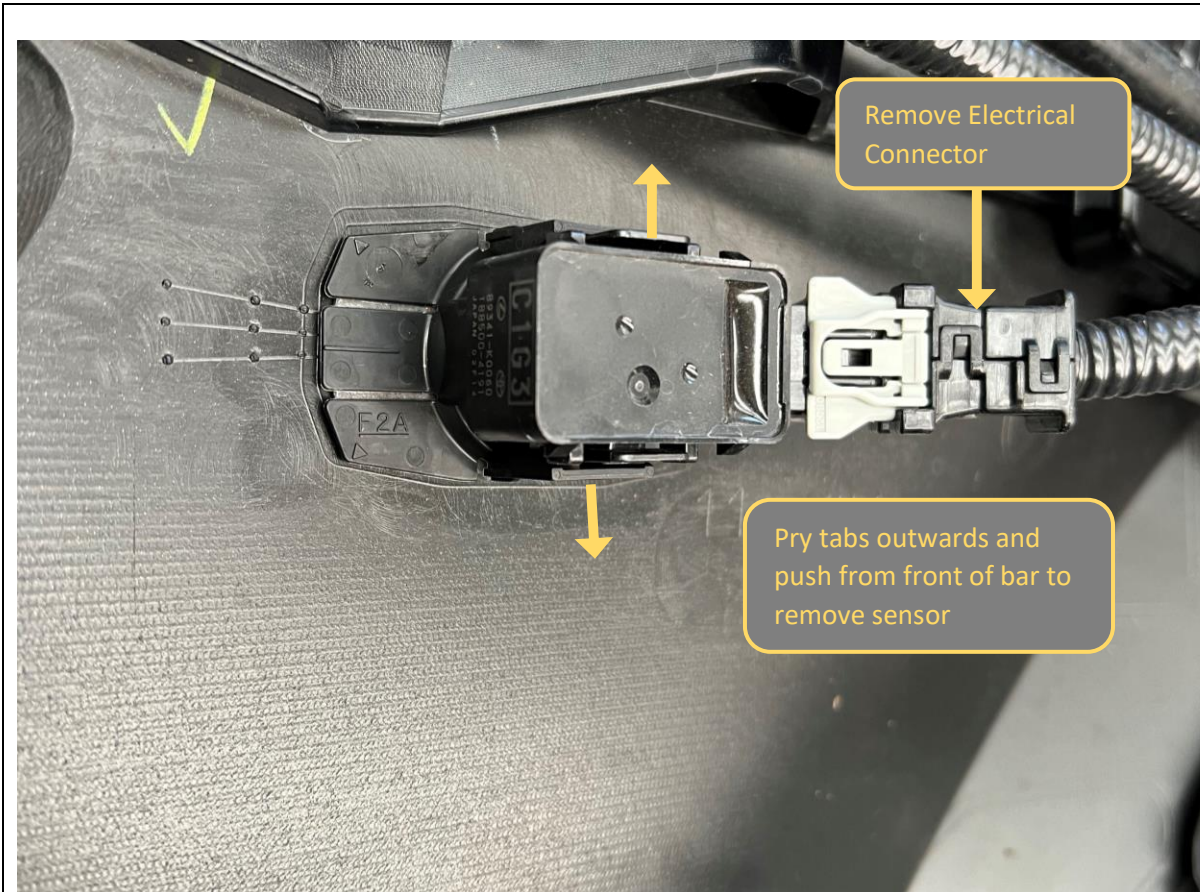

23. If car equipped with parking sensors Disconnect the parking sensors from the loom by squeezing the tab, then pulling to disconnect the multi plug connector.

24. Pry the two grey retaining tabs on the sensor housing outwards whilst applying pressure to the face of the sensor from the front side of the bumper. The sensor should release from the housing. Remove from the rear side of the bumper.

Take care to ensure the rubber isolation rings remain in place with the sensor

TOOLS REQUIRED

FASTENERS

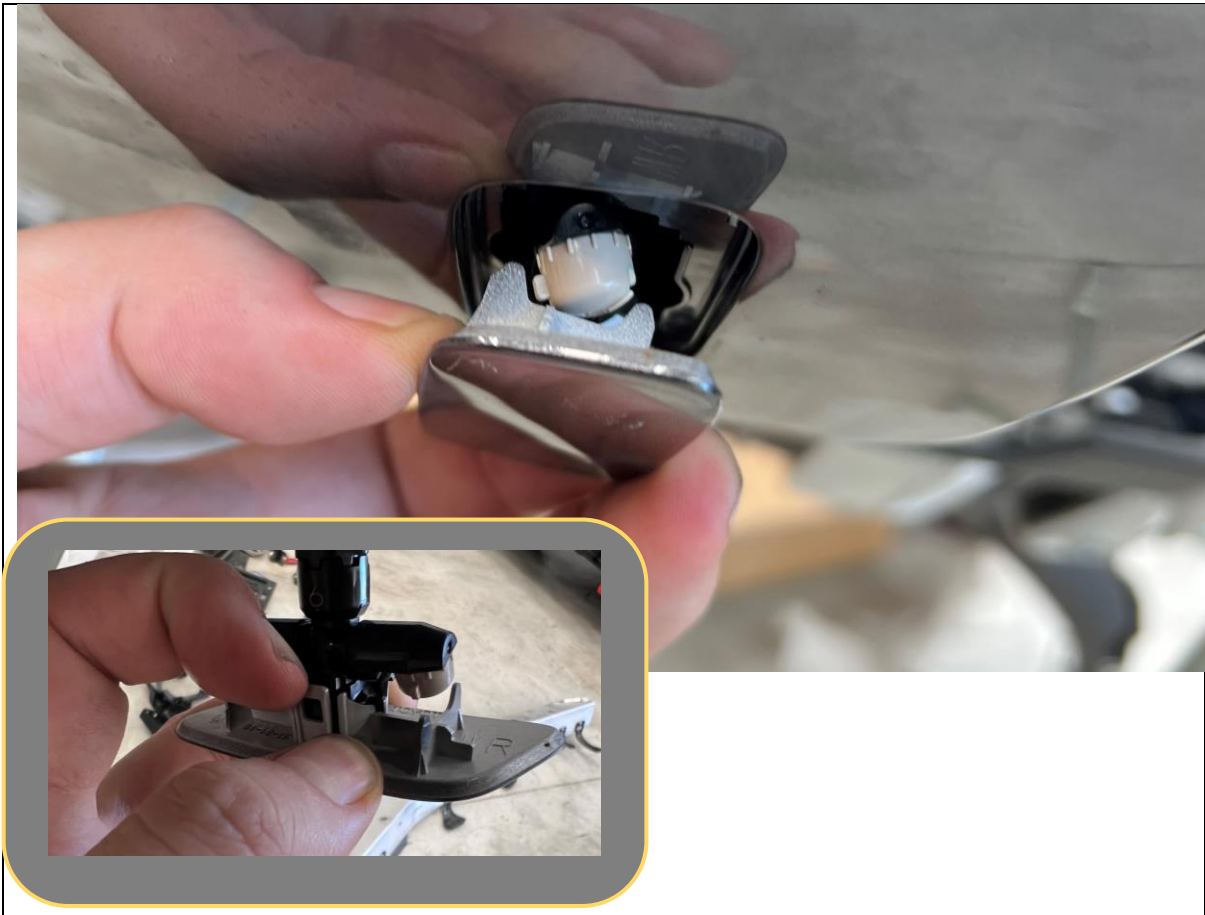

25. If equipped, Pull out headlight washer from bumper.
26. Release tabs holding trim panel to headlight washer by prying away from headlight washer.
27. Allow washer body to retract back into housing.

TOOLS REQUIRED

FASTENERS

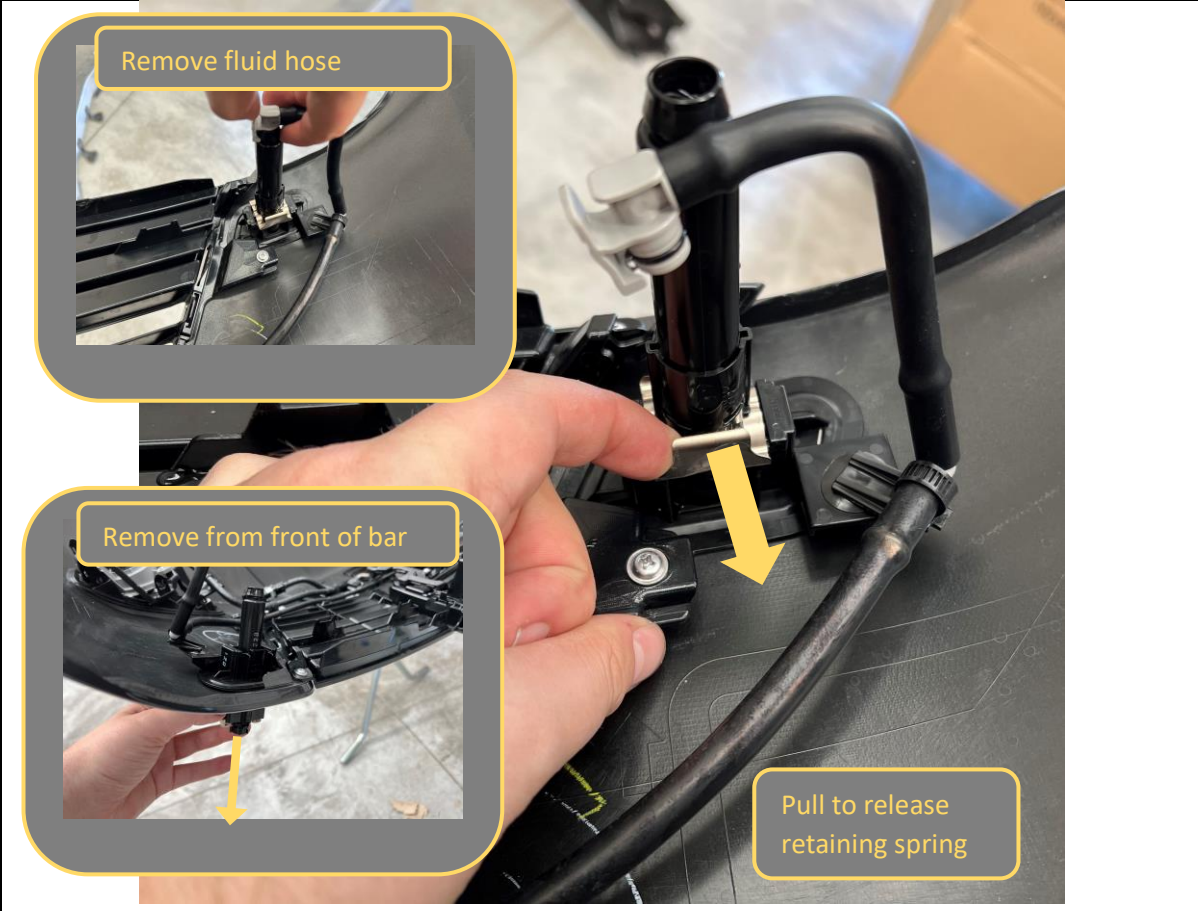
	
<p>28. If vehicle is equipped, remove headlight washers from the bumper. Start by disconnecting the supply hose.</p>	<p>TOOLS REQUIRED</p>
<p>29. Release the retaining spring by firmly pulling it as shown in the image.</p> <p>30. Once loose remove the washer by sliding forward, removing through the front of the bumper.</p>	<p>FASTENERS</p>

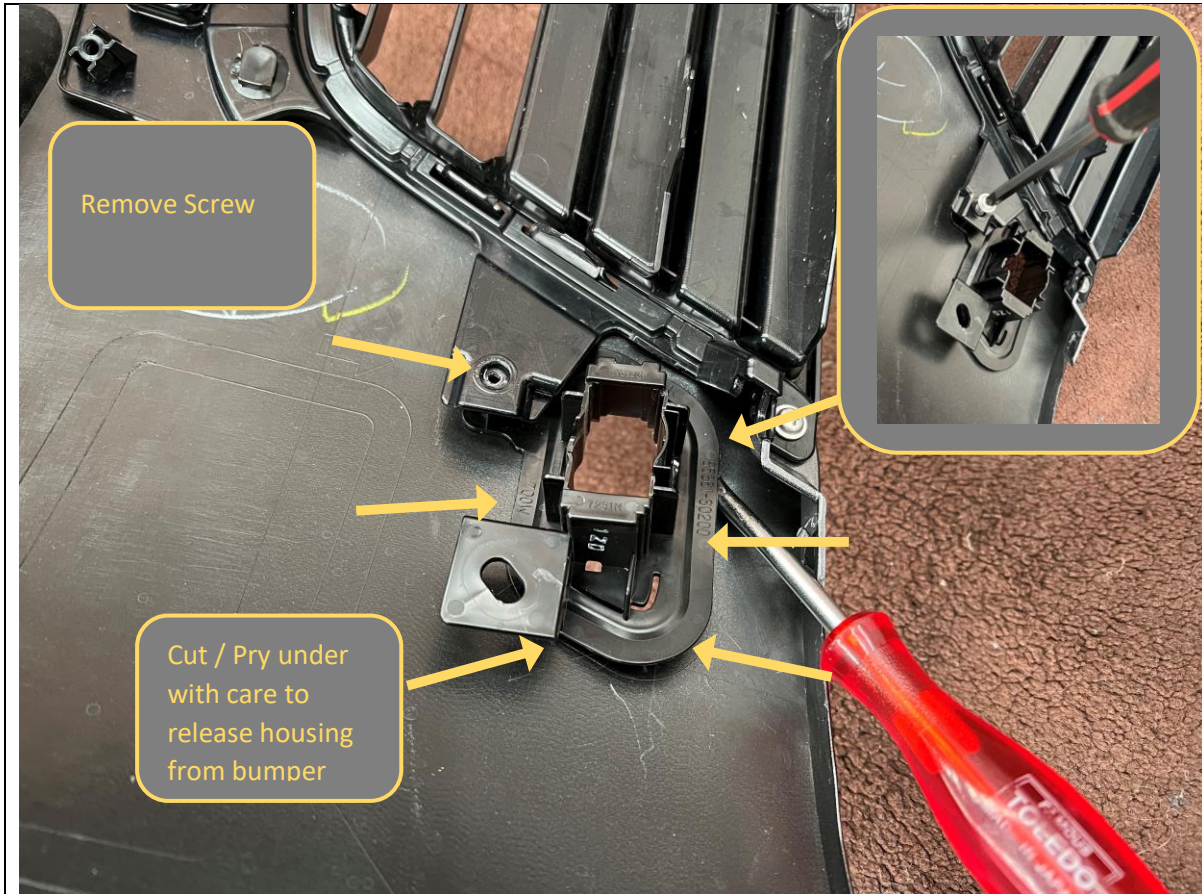

31. Remove the Phillips head screw holding the grille surround over the headlight washer.
32. Using a utility knife and trim tool carefully cut through the adhesive under the Washer housing and pry it from the bumper
33. Set aside housings taking care to note the correct positions for refitment.
34. Clean off all adhesive from face of washer mount.

TOOLS REQUIRED

Utility Knife
Trim Tool

FASTENERS

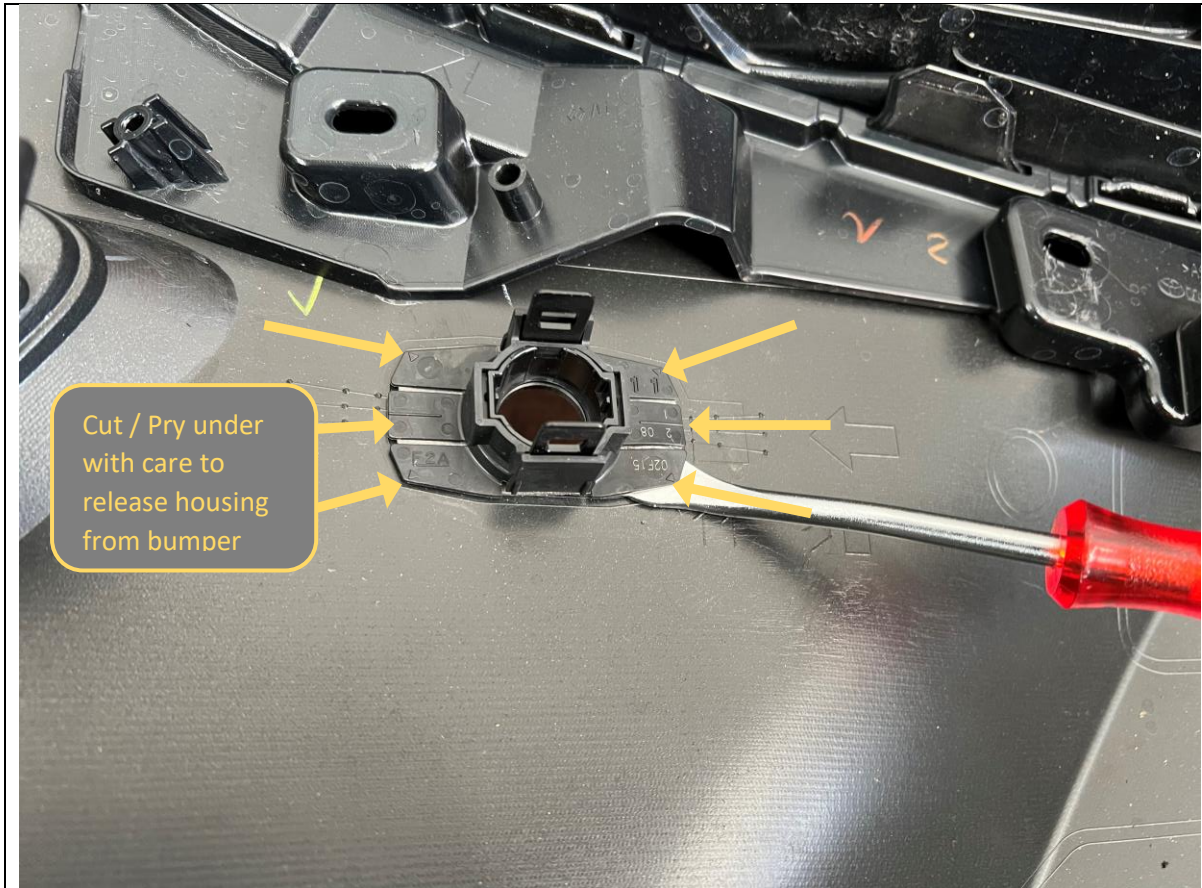

35. Remove the sensor housing from the bumper for refitment to the bar
36. Using a utility knife and trim tool carefully cut through the adhesive under the sensor housing and pry it from the bumper
37. Set aside housings taking care to note the correct positions for refitment
38. Clean off all adhesives from face of sensor mount.

TOOLS REQUIRED

Utility Knife
Trim Tool

FASTENERS

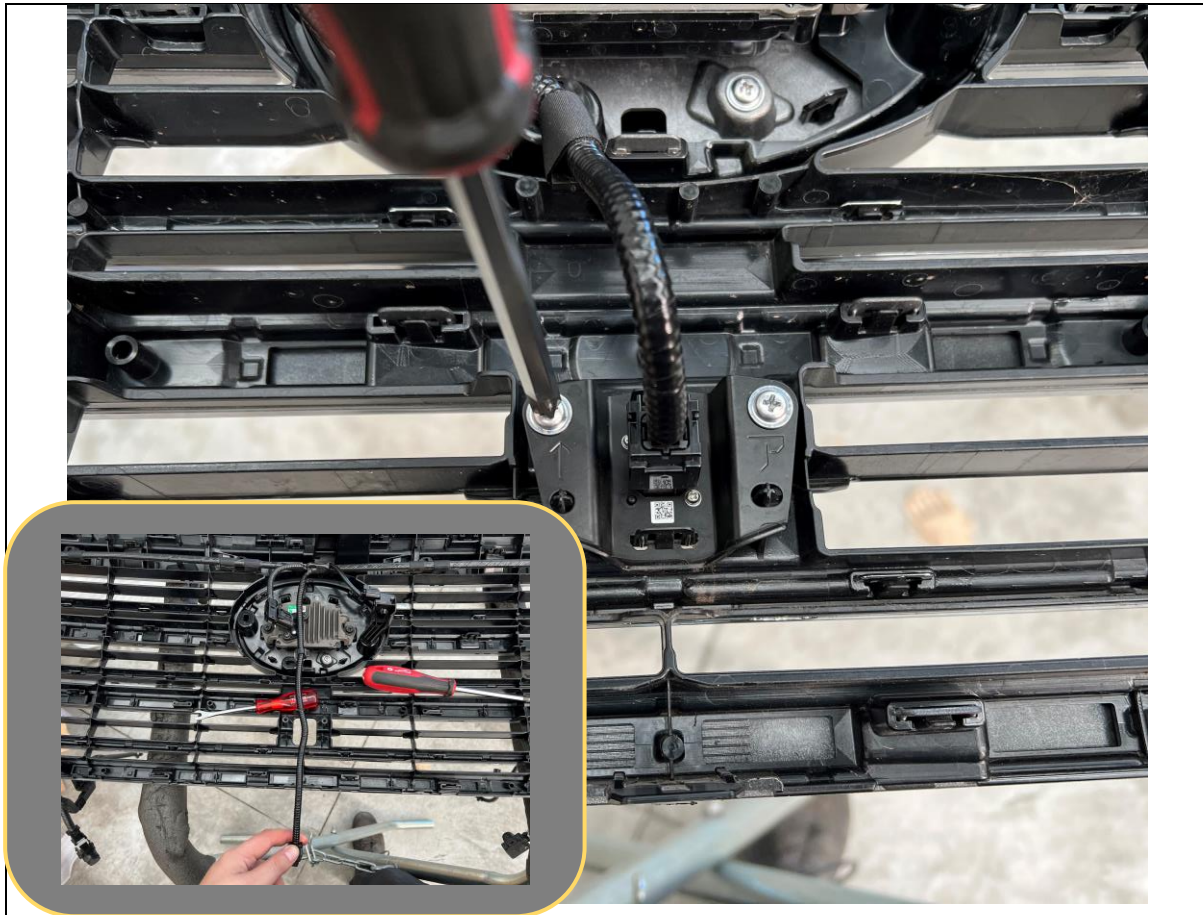

39. If vehicle is equipped, remove the front camera from the grille.
40. Disconnect the electrical harness, then remove the 2x Phillips head screws securing to bumper.
41. Once removed unclip the loom from the grille to allow cable to reach relocated position in bar.

TOOLS REQUIRED
Phillips Head screwdriver,
Trim Tool

FASTENERS

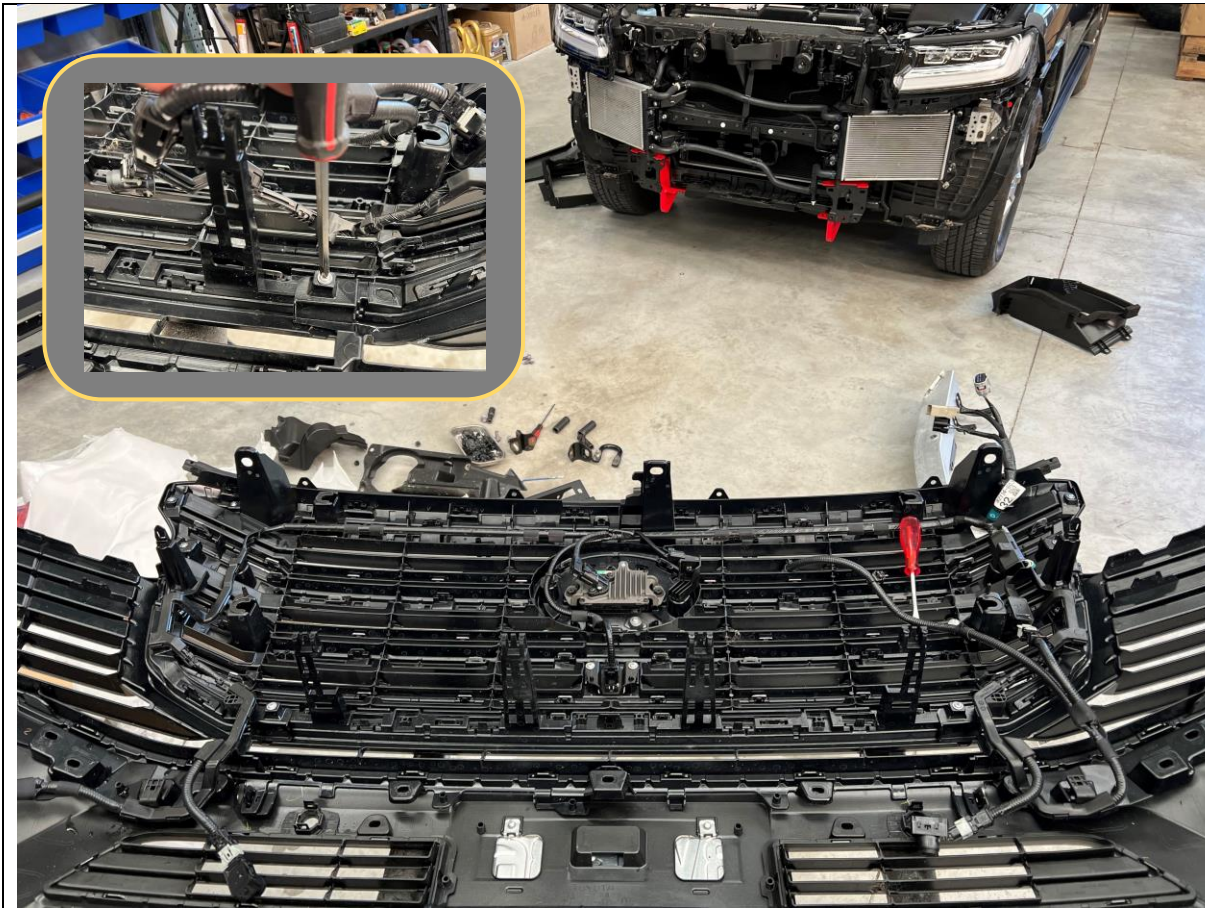

42. Separate the grille from the bumper.
43. The grille is secured by Phillips head screws and several molded clips
44. Begin by removing all Phillips head screws,
45. Progressively release clips, starting from outsides, and working towards the center.
46. Once separated Refit Grille to the vehicle, re-using all factory fasteners

TOOLS REQUIRED
Trim Tool
Phillips Head Screwdriver

FASTENERS



47. Remove the Plastic covering the impact beam.
48. The plastic is secured by molded clips in the front face, and clips on either end of the beam
49. Remove and set aside the plastic impact beam.

TOOLS REQUIRED

FASTENERS

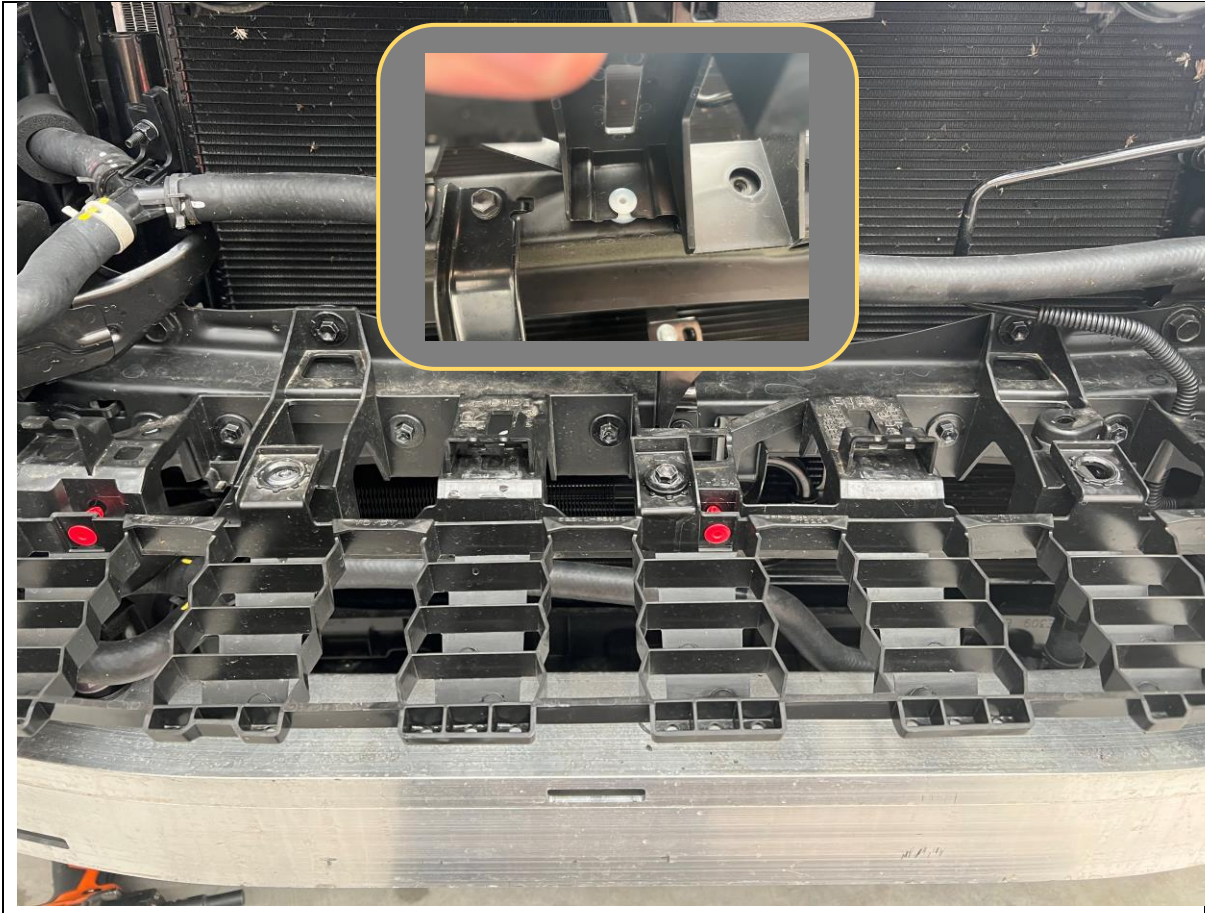

50. Remove the Plastic concertina panel by removing the 10mm head bolts and clips securing it to the crossbeam on the car.

TOOLS REQUIRED

10mm socket / spanner
Trim tool

FASTENERS



51. Remove the Plastic intercooler air guides by removing the 4x 10mm head bolts securing them.

TOOLS REQUIRED

10mm socket / spanner

FASTENERS

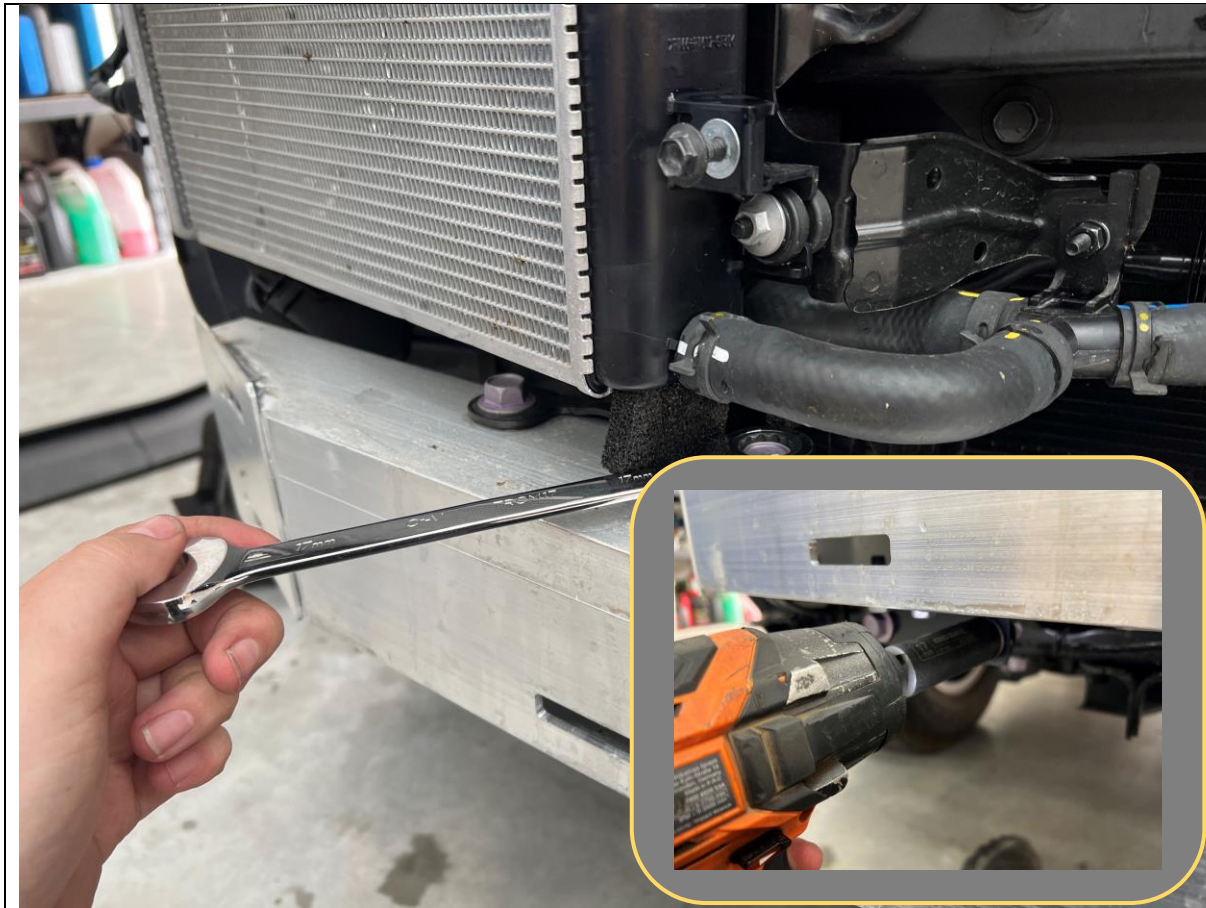

52. Remove the 4x 17mm head bolts holding the impact beam to the impact beam brackets
There are 2x bolts on top and 2x bolts underneath on both sides.

53. Remove and set aside the aluminum impact beam.

TOOLS REQUIRED

17mm Socket
17mm Spanner
Extension Bar

FASTENERS

8x 17mm Head factory Flange Bolts

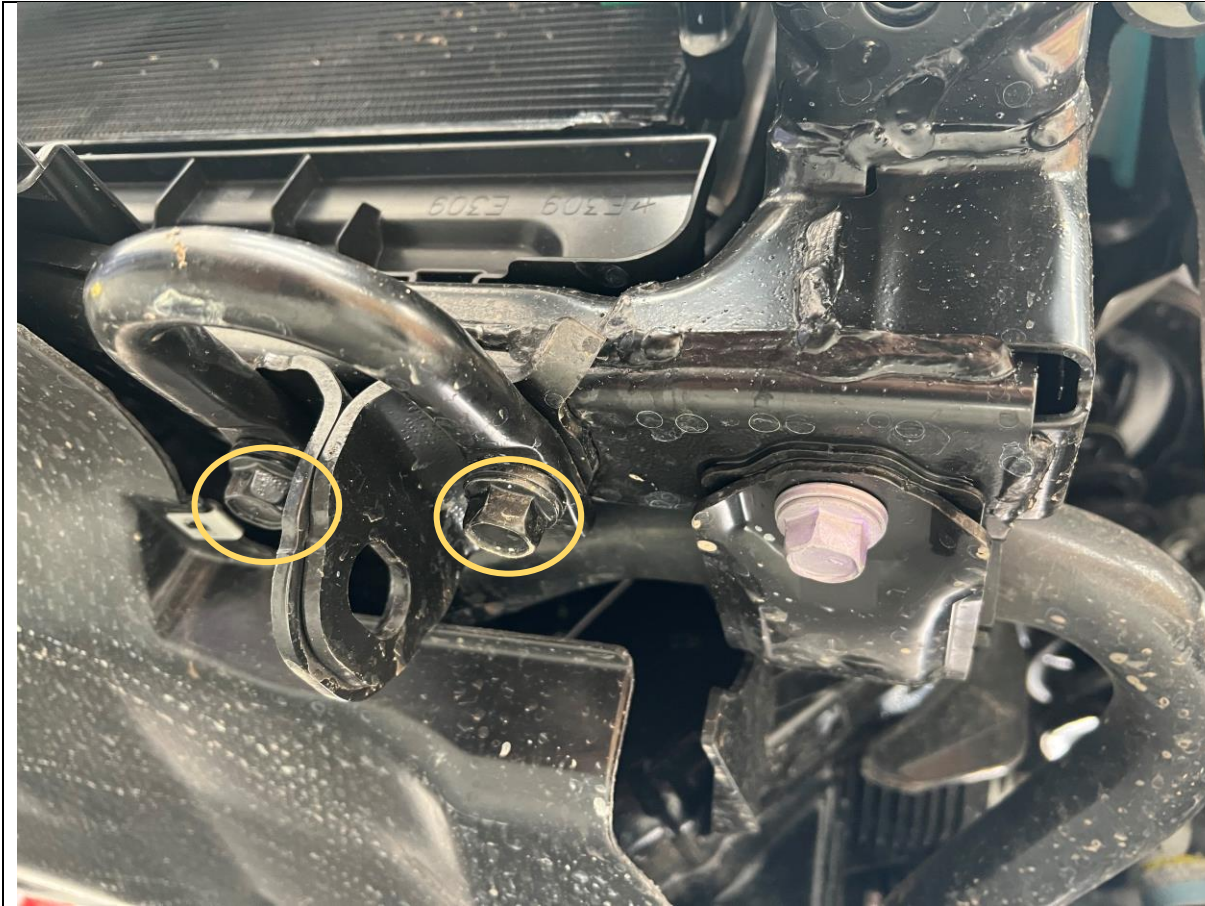

54. Remove the 2x 17mm head bolts Tow points to the lower chassis crossmember.
55. Remove and set aside the aluminum impact beam.

TOOLS REQUIRED
17mm Socket

FASTENERS
4x 17mm Head factory Flange Bolts

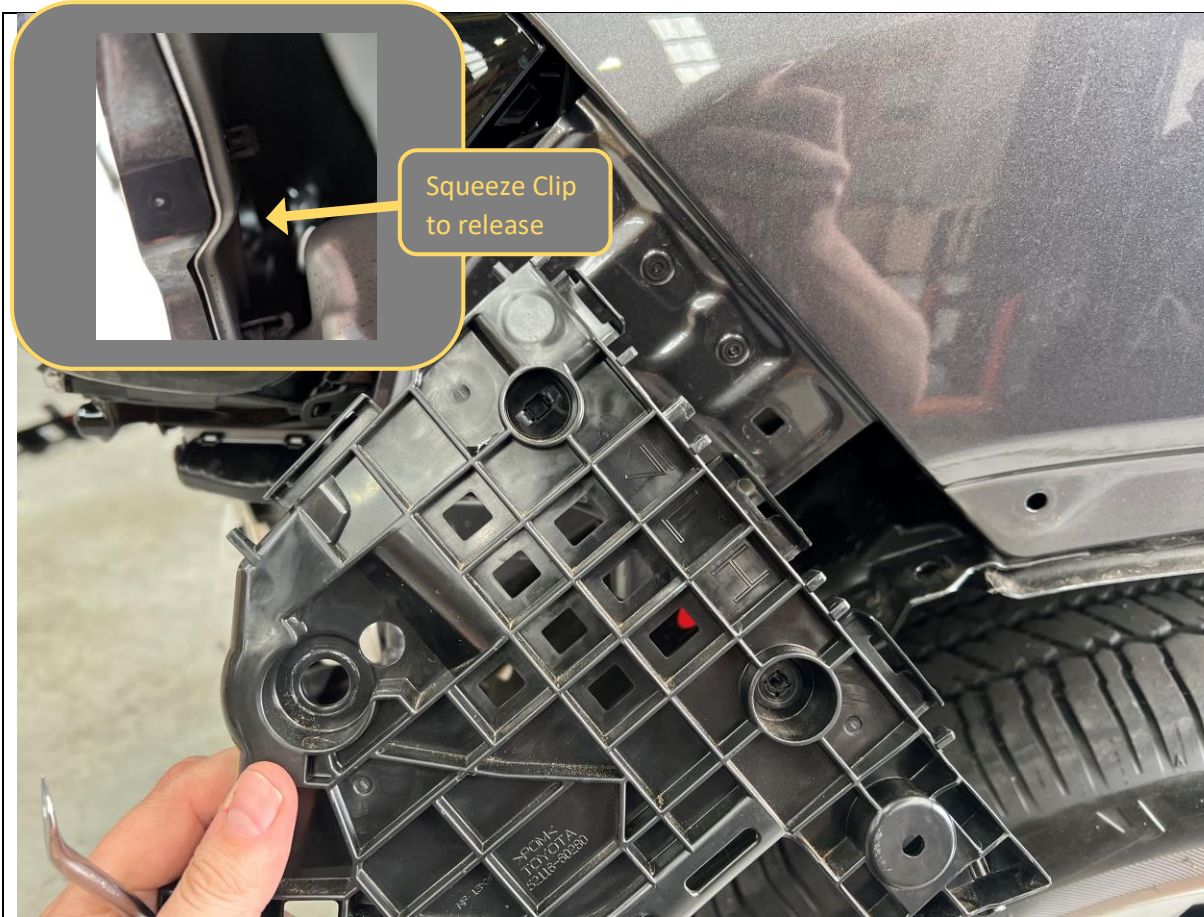

56. Remove the plastic bumper retainers by removing the Phillips head and 10mm head screws, then prying out the large clip from behind using trim tool

TOOLS REQUIRED

Phillips head screwdriver
10mm Socket
Trim Tool

FASTENERS

Phillips Head screw.

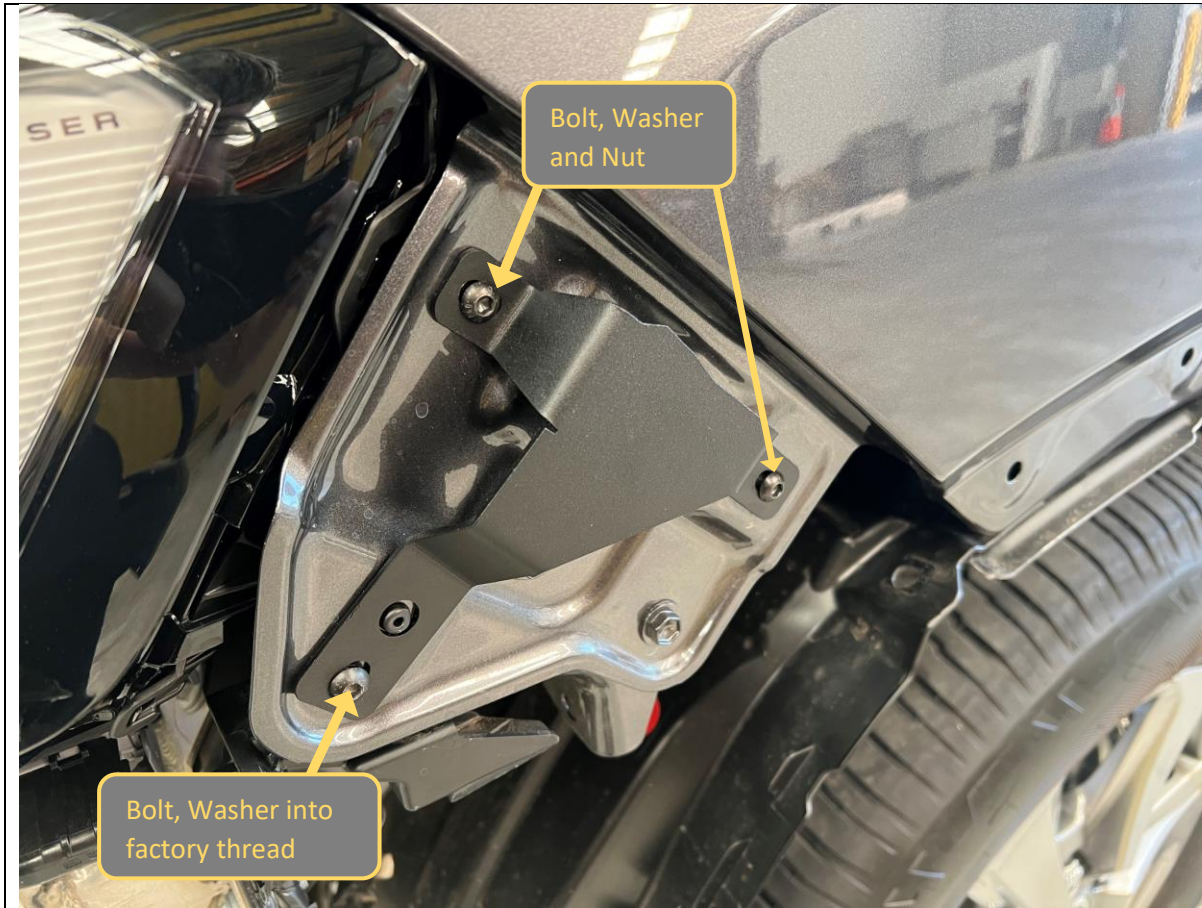

57. Fit the trim support bracket to the top corner of the front guard. Use supplied M6x16mm Button head bolts, Flat washers and Flange nuts for two rear locations.

Secure with supplied M6x16mm Button head bolts and Flat washer to factory thread in headlight for front point.

58. Complete on both sides of the vehicle.

TOOLS REQUIRED

4mm Hex Key

FASTENERS

Phillips Head screw.
Discard



59. Clean the infill support bracket and the inside of the headlight infill panel with isopropyl alcohol or similar cleaning solvent.
60. Place at least 3x Strips of VHB double side tape onto the flat portion of the infill support bracket.
61. Align and fit the headlight infill panel to the infill support bracket as shown.

TOOLS REQUIRED

VHB tape,
Isopropyl Alcohol

FASTENERS

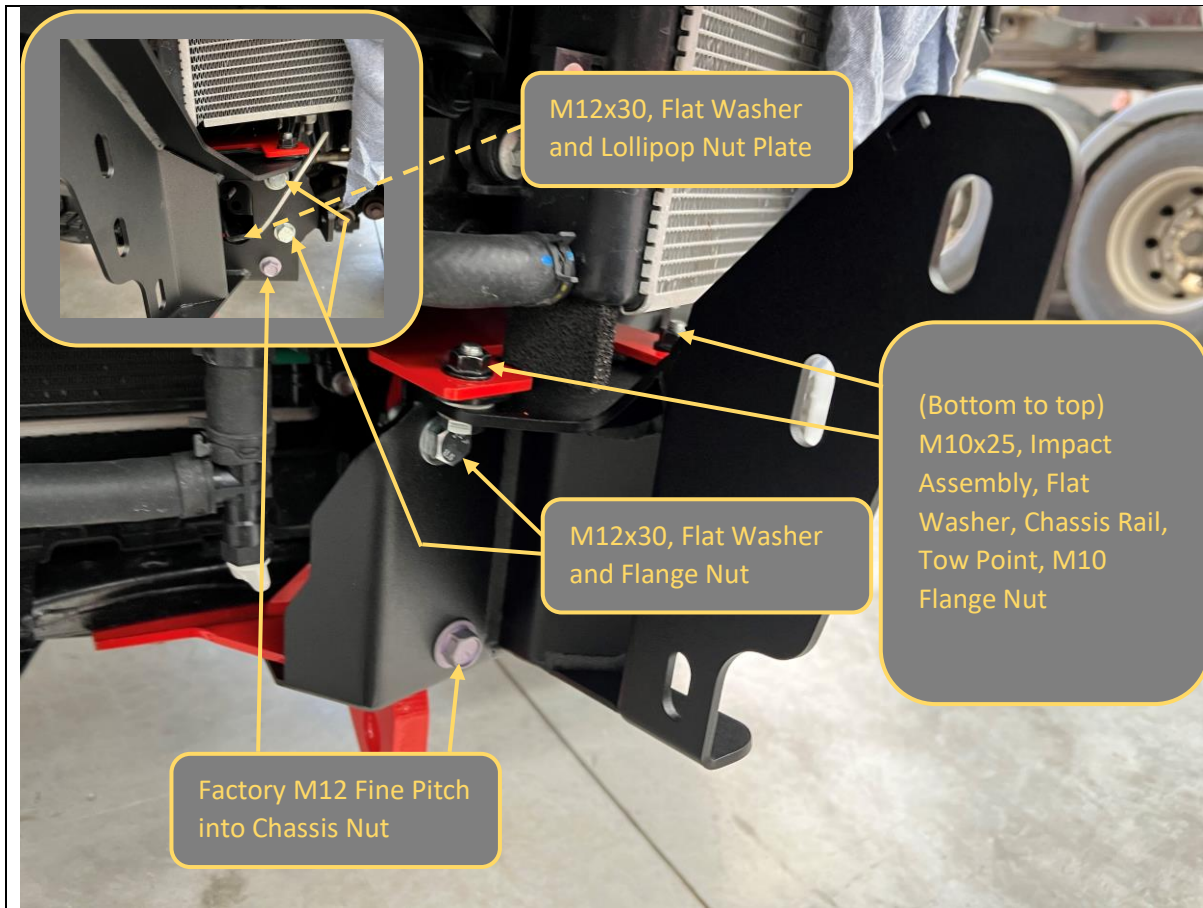

<p>62. Loosely fit the Impact mounts to the chassis, re using the original factory flange Bolts.</p> <p>63. Loosely fit the tow point to the chassis and impact</p> <p>Note: Captive threads in chassis can be tight. Ensure bolts are not cross threaded and drive in manually with socket. Do not tighten at this stage.</p>	<p>TOOLS REQUIRED</p>
<p>64. Leave bolts finger tight at this stage.</p>	<p>FASTENERS</p> <p>2x M10x25 Hex Bolt 4x M12x30 Bolt 4xM10 Flat Washer 4xM12 Flat washers 3XM12 Flange Nut 1x M12 Lollipop Nut Plate 2x M10 Flange Nut 2x Factory Fine Pitch Bolts</p> <p>Per side</p>

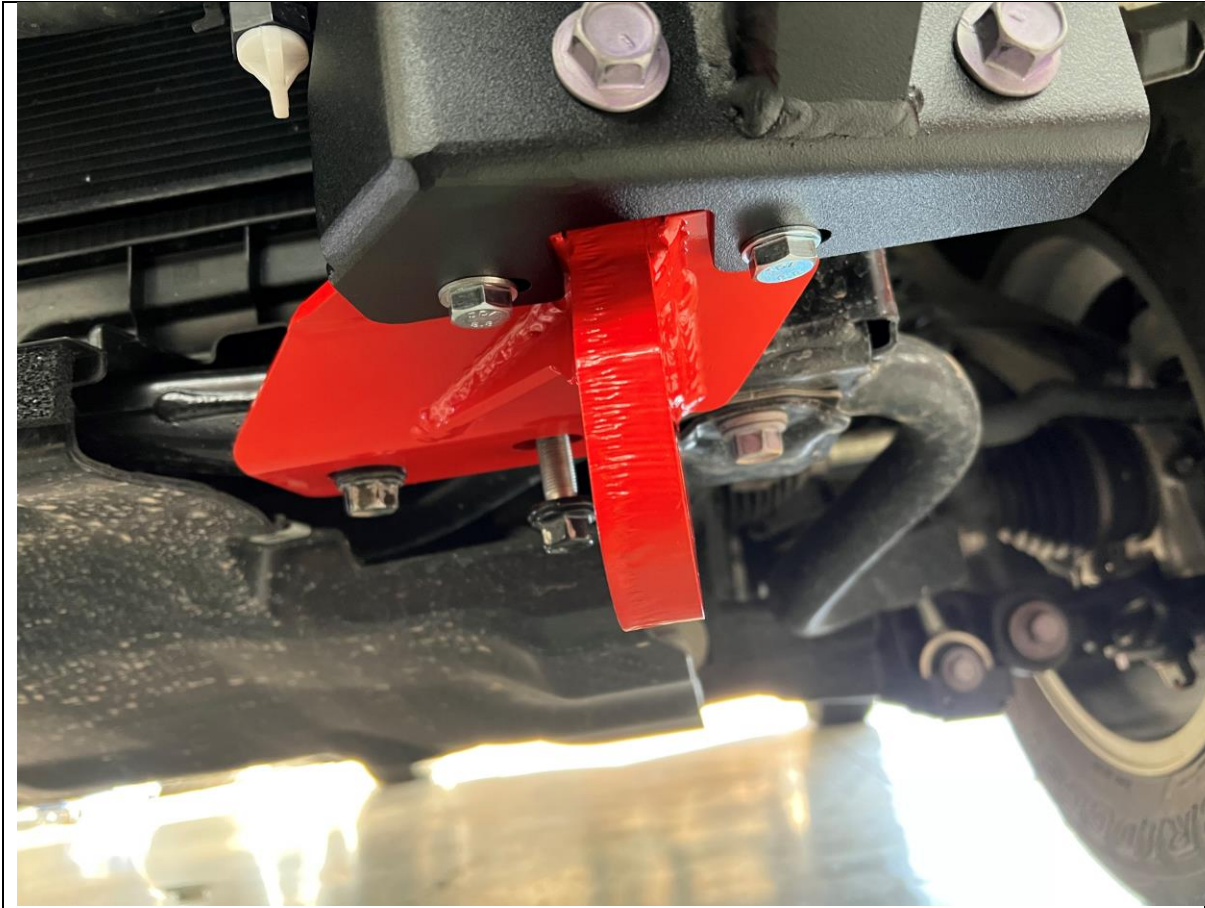

65. Tighten tow point to chassis bolts in the following order.
66. First, M12x30 bolt into lollipop nut plate that secures tow point to side of chassis rail
67. Next Factory M12 fine pitch bolts that secure tow point to lower crossmember.
68. Leave all bolts that secure tow point to the impact assembly, including the top flange bolts that go through chassis loose at this stage

TOOLS REQUIRED

17 & 18mm Sockets

FASTENERS

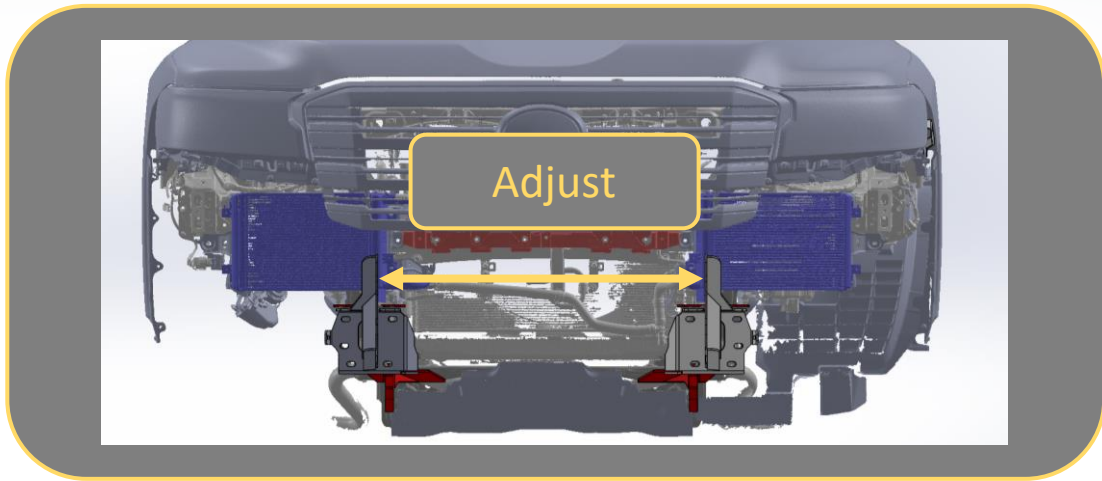
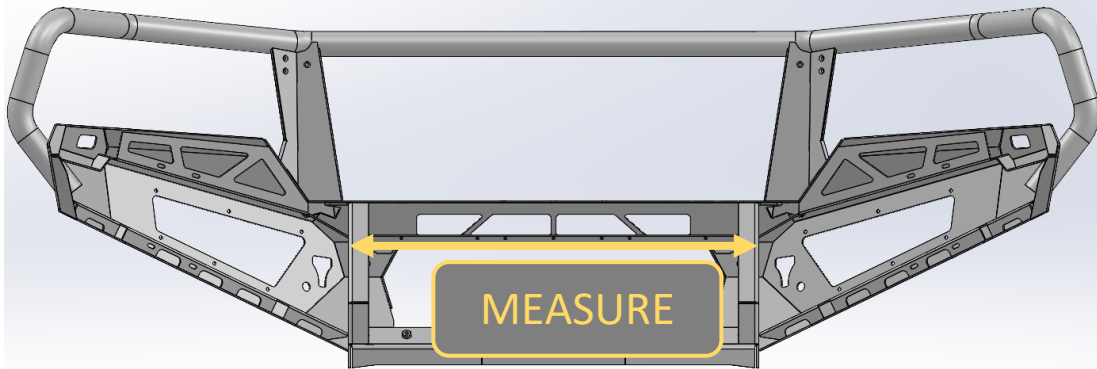

69. Measure Distance between outside edges uprights on bar using tape measure. Write distance below for reference if required.

Bar Upright Width = _____mm

70. Adjust mounts by sliding mounts on slots, such that distance between outside edges of mounts is approximately 2mm less than bar.

71. Secure and tighten mounts. Tighten bolts that secure the tow point to chassis first, then impact assembly to tow point bolts.

TOOLS REQUIRED

TAPE MEASURE

FASTENERS

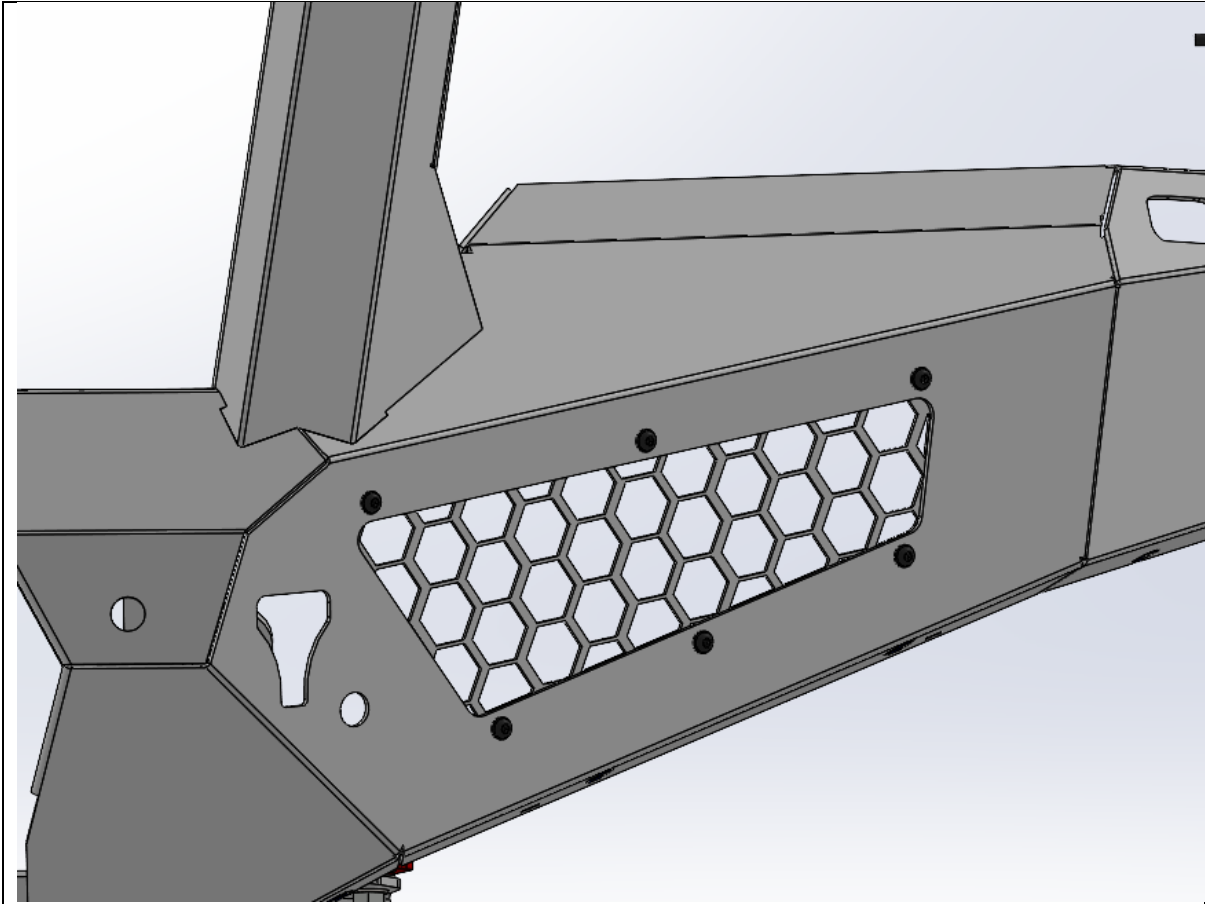

72. Fit the mesh panels to the wings, using the supplied M6x16 Button head bolts, flat washers, and Flange Nuts.

TOOLS REQUIRED

4mm Allen Key
10mm Spanner / Socket

FASTENERS

6x M6x16 BHCS – Black
6x M6 Flat Washer
6x M6 Flange Nut
per Side

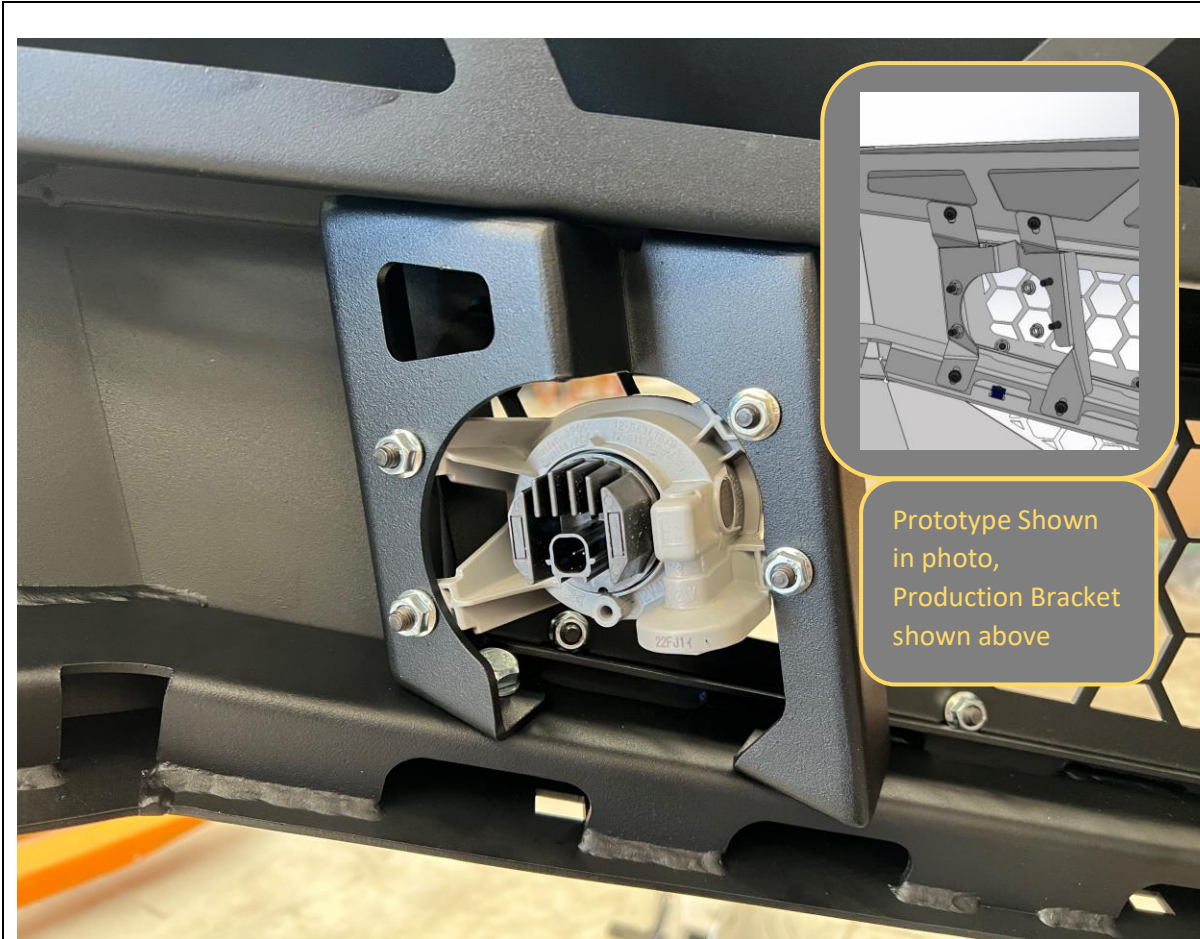

73. Re-Fit fog lamps to the Fog light brackets using M6X16 Button head Bolts, Flat washers, and Flange nuts from the Small Parts Kit.
74. Secure and tighten using 4mm Allen Key and 10mm Spanner
75. Fit the fog light bracket to the wing of the bar, using supplied fasteners.

TOOLS REQUIRED

4mm Allen Key
10mm Spanner / Socket

FASTENERS

8x M6x16 BHCS – Black
8x M6 Flat Washer
8x M6 Flange Nut
Per Side

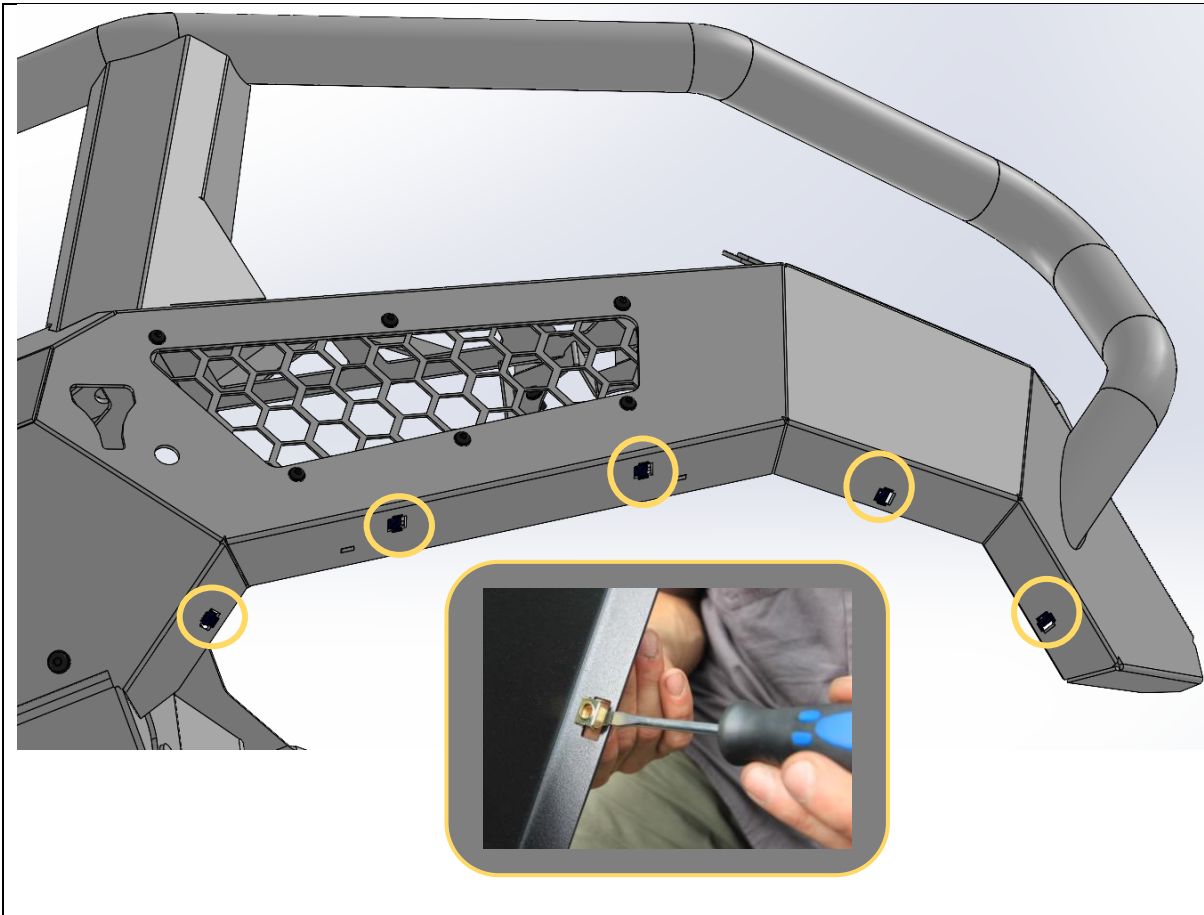

76. Fit 5x Cage nuts from small parts kit to rectangular slots in bottom of wing.

Use a small flat bladed screwdriver to push the edge of the cage to engage with the slot to aid fitting.

77. Repeat for other side of Bar

TOOLS REQUIRED

Small Flat Bladed Screwdriver

FASTENERS

5x M6 Cage Nut
Per side

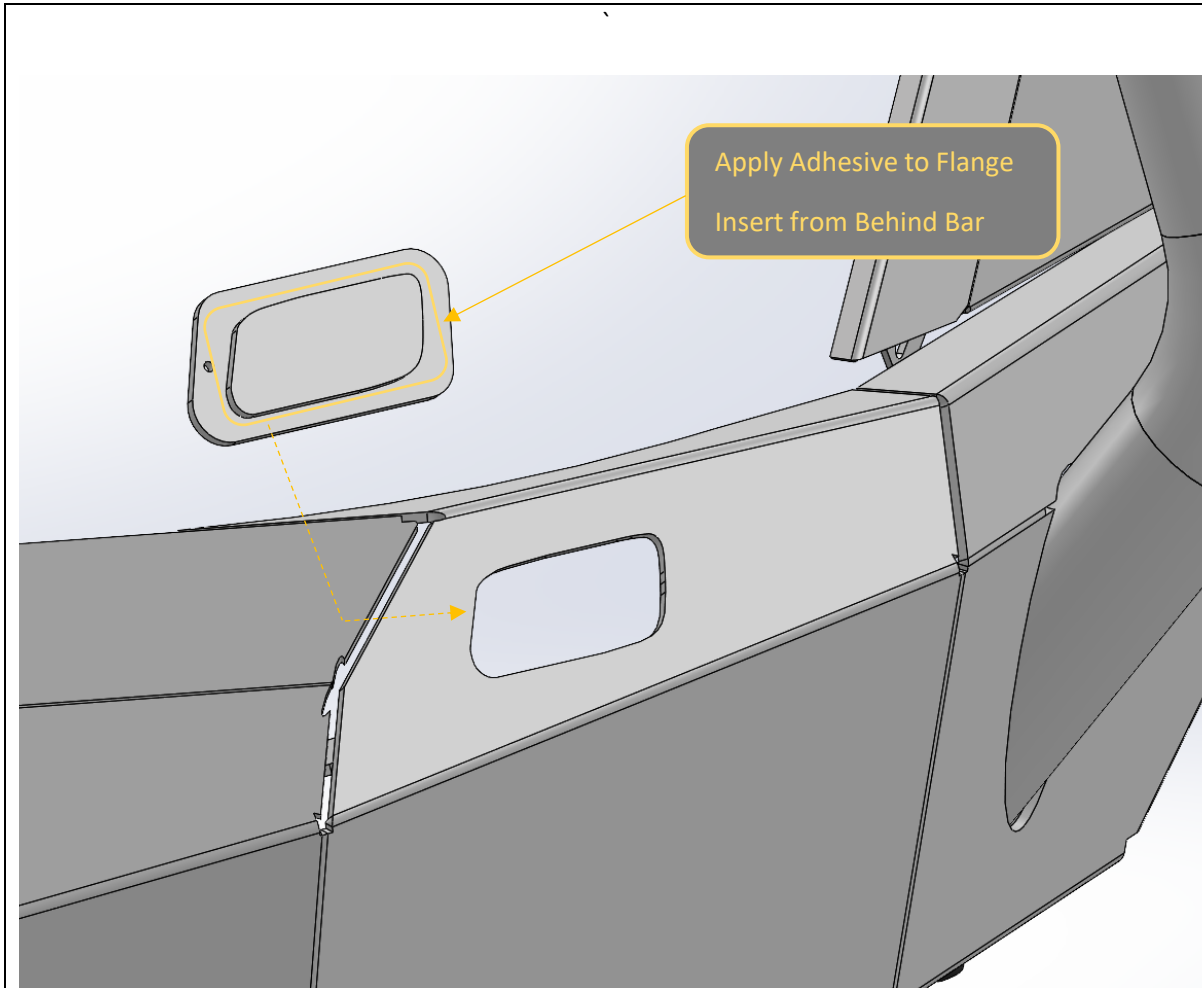

78. If not fitting headlight washers install supplied plug plates, using Automotive grade adhesive (Offroad Animal recommends Sikaflex227)

TOOLS REQUIRED

Automotive adhesive

FASTENERS

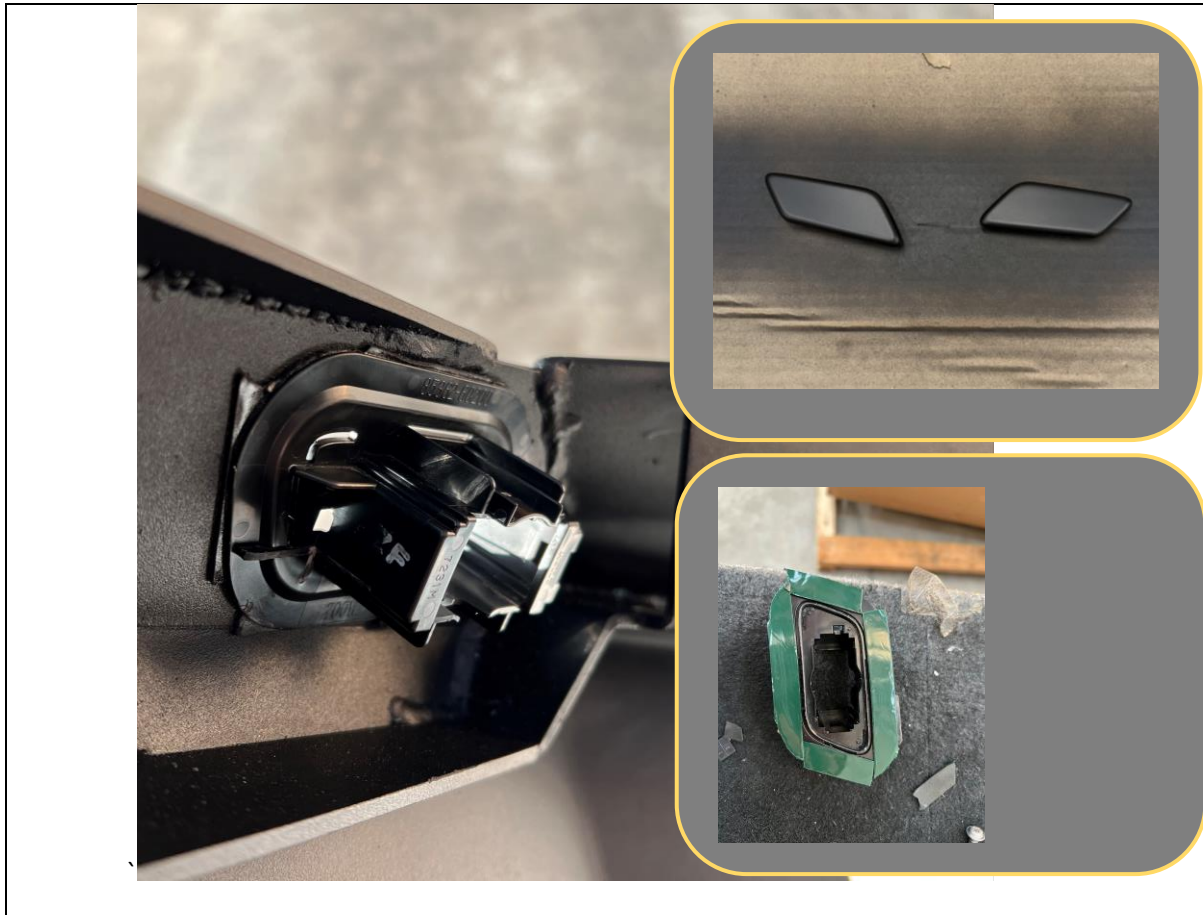

- 79. If Equipped Re fit headlight washers to bar.
Fitment procedure is reverse of removal
- 80. If the bar is not to be colour coded, paint the headlight washer covers black before refitting
- 81. Thoroughly clean both the bar and headlight washers on faces where adhesion will occur.
- 82. Apply VHB double side tape to the flange on the headlight washer housing.
- 83. Fit the housing to the cutout in the bar.

TOOLS REQUIRED

Scotch Brite / Sandpaper
Matte Black Paint
Isopropyl Alcohol
VHB double side tape

FASTENERS



84. Re fit the headlight washers into the housings, using the opposite of the removal procedure.

85. Re fit washer hoses to bar, and to washers.

86. Once fitted pull out the washer assembly with long nose pliers and adjust the washer nozzles to squirt towards the headlights, final adjustment can be performed when the bar is fitted to the car.

TOOLS REQUIRED

Long Nose Pliers

FASTENERS

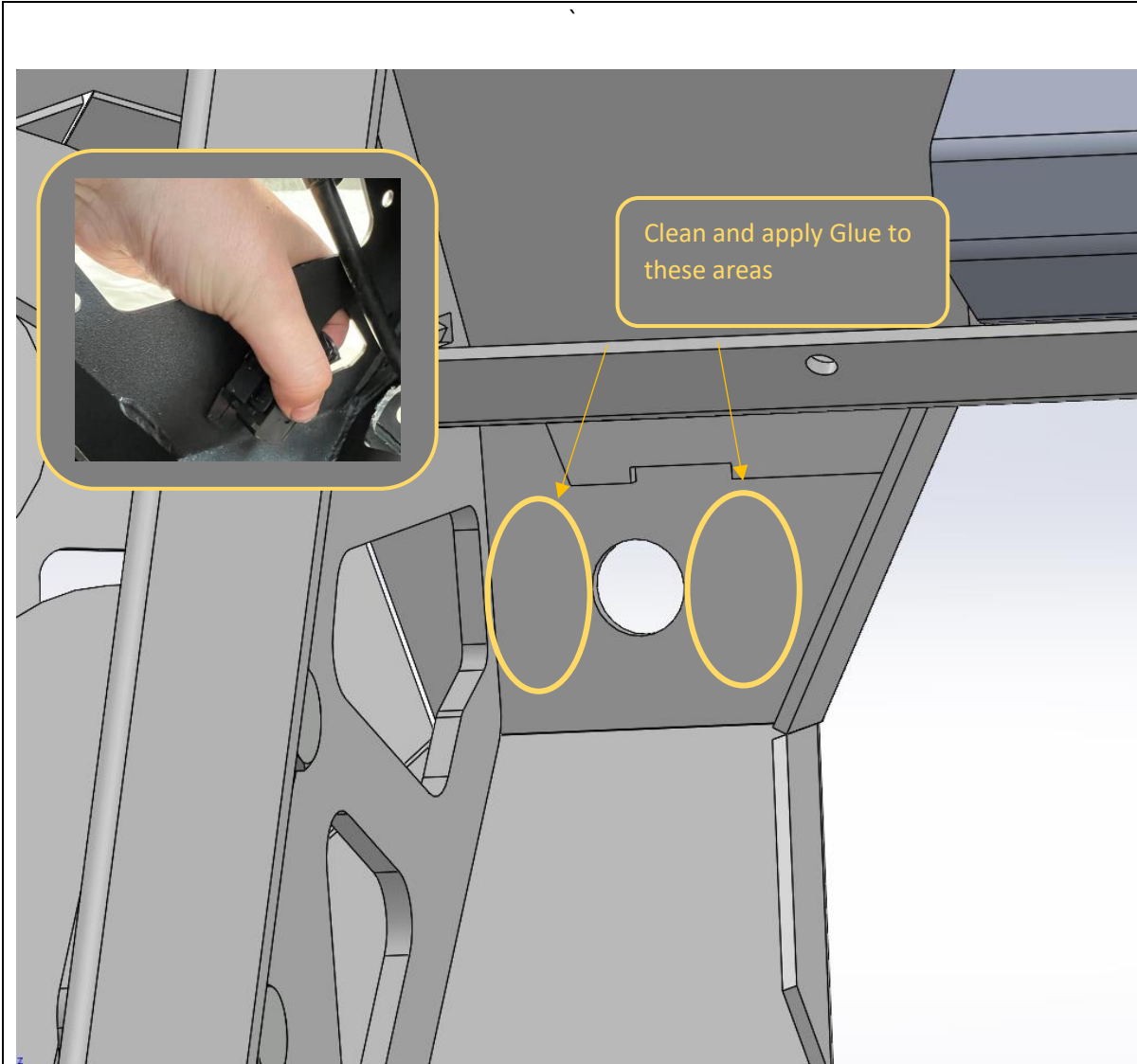

<p>87. Re Fit parking sensors to the bar.</p> <p>88. Clean area on back side of bar adjacent to sensor holes with isopropyl alcohol.</p> <p>89. Refit sensors to housings to help locate housing during gluing process</p>	<p>TOOLS REQUIRED</p> <p>Automotive adhesive</p>
<p>90. Apply a small amount of automotive grade adhesive (ORA recommends Sikaflex227) around the hole and glue the sensor housings in place, in their original positions. Hold in place with tape until glue sets.</p> <p>91. Refit Headlight washer hose to bar. Secure using cable ties.</p> <p>92. If parking sensor not fitted, fit cover pugs by pushing into hole.</p>	<p>FASTENERS</p>

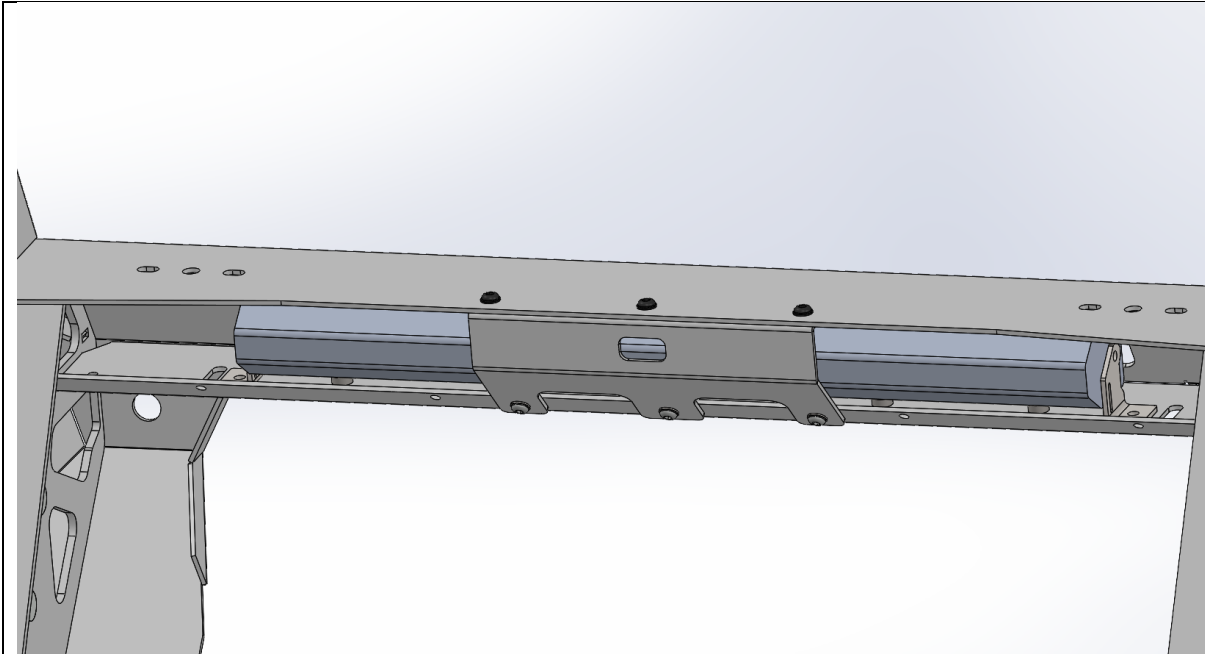

<p>93. If Fitting an integrated light bar, do so now.</p> <p>94. The bar is designed to fit an Offroad Animal 22in or STEDI ST3K 21.5 inch light bar. If fitting this light bar, assemble bar with legs out, and it will line up with the slots in the center gusset. Secure with M8 Fasteners supplied with the light bar.</p>	<p>TOOLS REQUIRED</p> <p>13mm Spanner / Socket 4mm Hex Key</p>
<p>95. The bar can accommodate most other “20 inch” size light bars.</p> <p>96. If fitting driving lights to the bar this is also the most convenient time to do so</p> <p>97. After fitting driving lights, fit the Pan brace to the back of the bar, between the pan and center gusset using Supplied M6x16 (top) and M6x12 bolts, Flat washers and Flange Nuts</p>	<p>FASTENERS</p> <p>Supplied with Light Bar</p> <p>3x M6x16 Black BHCS 3x M6x12 BHCS 6x M6 Flat washer 6x M6 Flange Nuts</p>



98. With assistance, either from another person, or a lifting trolley, lift the bar onto the mounts on the vehicle.

99. Secure with 4x M12x30 Bolts, Heavy Duty washers and M12 Nyloc and Flange Nuts per side, Finger tight at this stage.

TOOLS REQUIRED

Lifting Trolley

FASTENERS

8x M12x30 Bolt
12x M12 Heavy Duty Large Washer
2x M12 Nyloc Nut
12x M12 Flange Nut



100. With assistance, from another person, Align the bar with the edges of the vehicle. Adjust such that the clearances are neat and even side to side.

Acceptable range of clearances shown in image above.

101. Once in position tighten the M12 Bolts using socket and spanner. An impact driver may be used to speed up this process.

TOOLS REQUIRED

Lifting Trolley
18/ 19mm Socket and Spanner

FASTENERS



- 102. If Fitting a winch, do so now.
- 103. If winch has top mount control box, the center tab at bottom of grille will need to be cut off to allow clearance. This can be done with side cutters.
- 104. The bar is designed to fit most low mount winches, in foot down configuration. WARN ZEON 10 is largest winch confirmed to fit.
- 105. The control box can to be mounted on top of the winch. Winches usually come with a bracket to allow this. Refer to winch manufacturer.
- 106. Ensure clutch handle will be accessible through access hole in front mesh panel. Refer to winch instructions regarding changing clutch handle location.

TOOLS REQUIRED

Refer to winch fitting instructions

FASTENERS

Supplied with winch



107. If Required, Fit winch fairlead to Mesh Fairlead Mount Use M10 or 3/8" Fasteners supplied with winch. The bar is only compatible with Hawse type fairleads.
108. If equipped fit the front camera removed earlier to the mesh fairlead mount using supplied M6x16 button head bolts, Flat washers, and Flange nuts
109. Fit Number plate flip bracket to fairlead mount, M8x25 Bolt, Flat washer, Nylon washer and Nylon Lock nut. Ensure nylon washer sits between the bracket and fairlead mount.

TOOLS REQUIRED

13mm Spanner
10mm Spanner
4mm Hex Key

FASTENERS

2x M8x16 Button Head
2x M8x20 Hex Head
2x M8 Flange Nut
4xM8 Flat Washer



- 110. As the mesh panel is offered to the bar- re connect the front camera wiring harness if equipped
- 111. Fit the Mesh Fairlead Mount to the center of the bar, using M8x16 Button head (Top), M8x20 Hex (Bottom) M8 Flat washers and M8 Flange Nuts (Bottom Only).
- 112. Tighten fasteners using 13mm socket / spanner and 5mm Allen Wrench.

TOOLS REQUIRED

13mm Spanner
5mm Allen Wrench

FASTENERS

2x M8x16 Button Head
2x M8x20 Hex Head
2x M8 Flange Nut
4xM8 Flat Washer

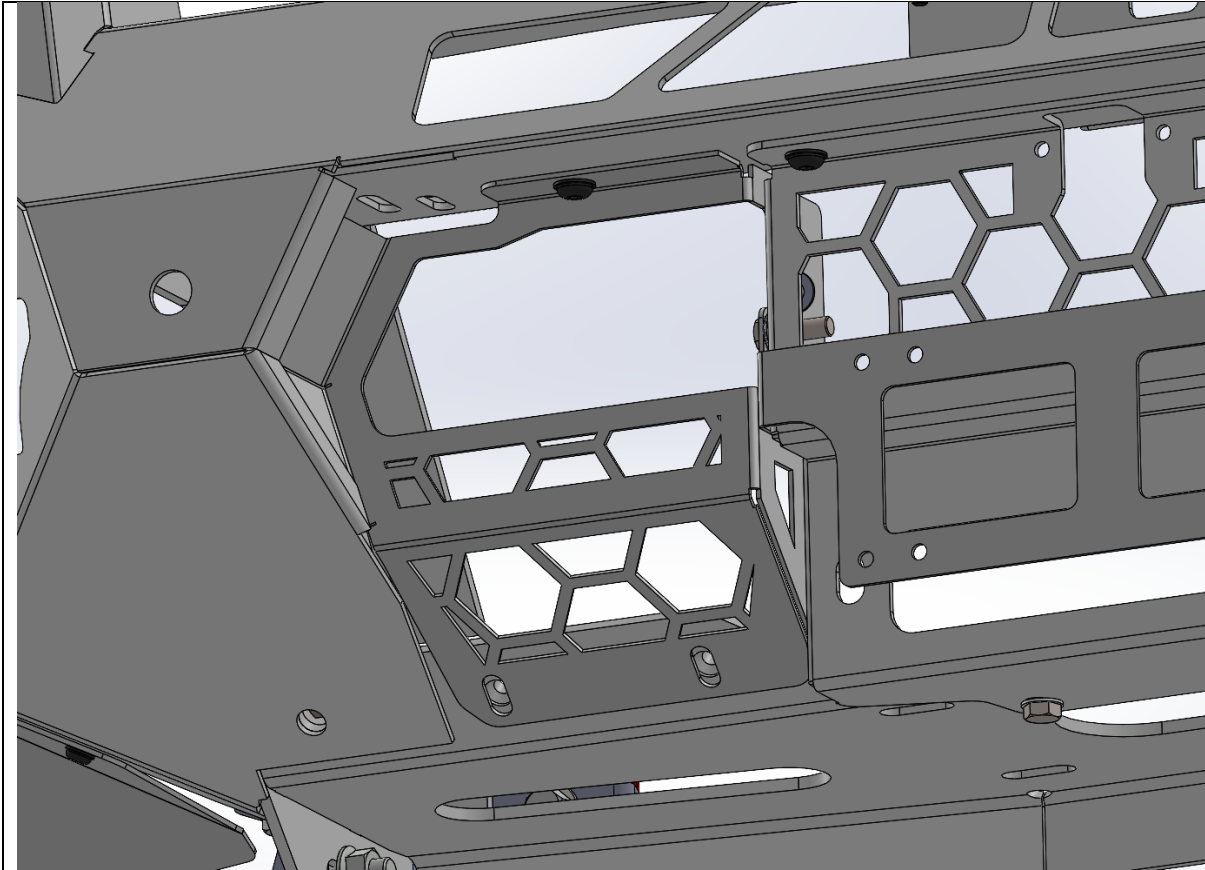

<p>113. Fit side Mesh Infill Panels Use M8x16 Button head bolt, M8 flat washer into the captive thread in the bull bar.</p> <p>114. Don't fit any bolts to bottom holes at this stage.</p> <p>115. Tighten top fasteners using 5mm Hex Key.</p>	<p>TOOLS REQUIRED</p> <p>13mm Spanner 5mm Allen Wrench 10mm Spanner 4mm Allen Wrench</p>
	<p>FASTENERS</p> <p>2x M8x16 Button Head 2x M6x16 Hex Head 2x M8 Flange Nut 2xM8 Flat Washer 2xM6 Flange Nut 2xM6 Flat washer</p>

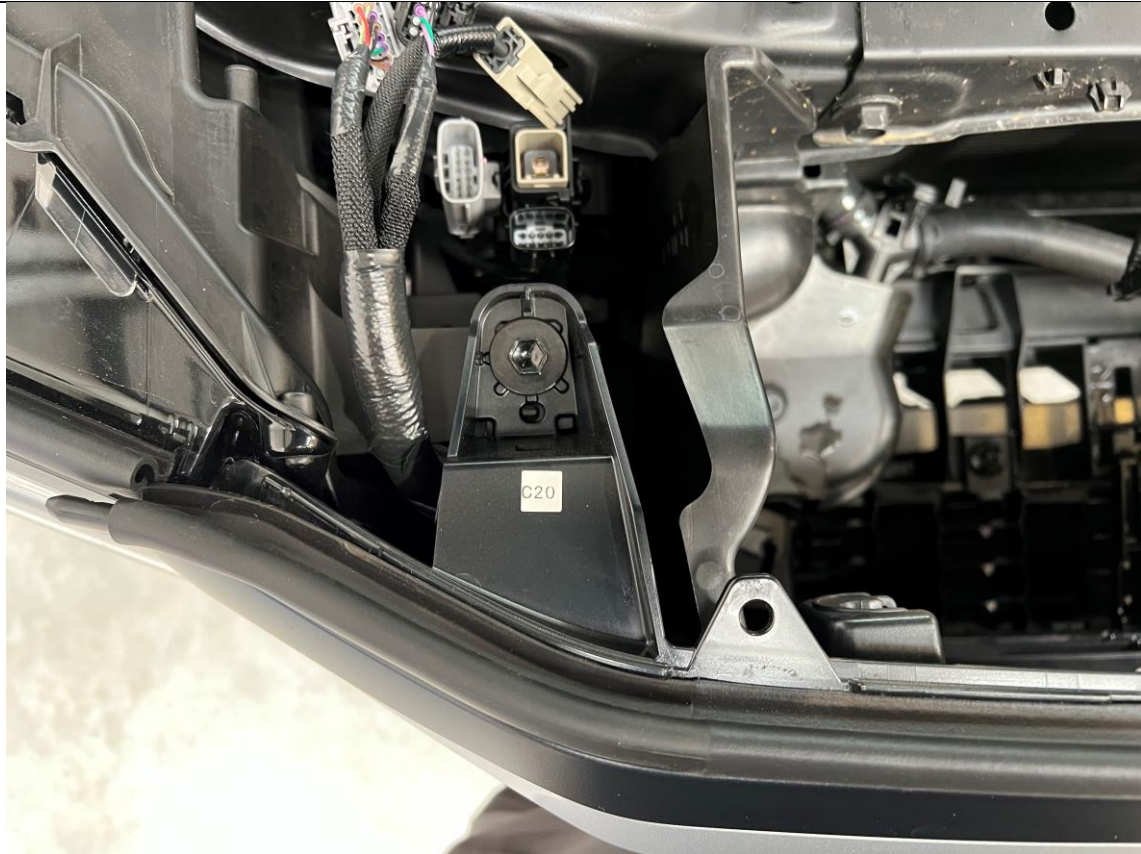

- 116. Re Connect Electrical Harness, fog lights and headlight washer hose.
- 117. Replace upper radiator cowl using original clips.

TOOLS REQUIRED

FASTENERS

Factory clips (re-use)



<p>118. Re-fit parking sensors to housings mounted in the bar, reaching from underneath the wing to do so.</p> <p>119. Reconnect wiring harnesses and cable tie harnesses neatly.</p>	<p>TOOLS REQUIRED</p>
	<p>FASTENERS</p> <p>Factory clips (re-use)</p>



120. Remove 4x factory bolts securing the bottom of the tow point to the crossmember.
121. Fit Center Bash Plate using, M8x30 button head, flat washer front face. Ensure these fasteners pass through the side mesh panels also.
122. Secure back of Center Bash Plate using the flange factory bolts removed earlier. The bash plate should sit immediately below the tow point.
123. Tighten Bottom fasteners using 17mm Socket
124. Tighten front fasteners using 5mm Hex key.

TOOLS REQUIRED

10, 13 mm Spanner
5 mm Allen Wrench

FASTENERS

6x M8x30 Button Head
6xM8 Flat Washer



<p>125. Fit Side Under panels using, M6x16 button head and flat washer into the cage nuts placed earlier.</p> <p>126. Tighten with 4mm Allen wrench</p> <p>127. Secure back of side under panel to tow point using M8x20 Hex Bolt, Flat washer, and M8 Flange Nut.</p>	<p>TOOLS REQUIRED</p>
<p>128. Leave finger Tight at this stage</p>	<p>FASTENERS</p> <p>10x M6x16 Button Head 10x M6 Flat Washer 2x M8x25 Hex Head 2x M8 Flange Nut 2x M8 Flat Washer</p>



129. Using the edge of the under panel as a guide mark the wheel arch liner, approximately 15mm beyond the intersection of the under panel.

130. Cut along line as marked using utility Knife

131. Tuck the wheel arch liner behind the flange on the under panel

132. Tighten all under panel bolts

133. Complete for other side of vehicle.

TOOLS REQUIRED

Utility Knife
13mm Spanner
5mm Allen Wrench
4mm Allen Wrench

FASTENERS

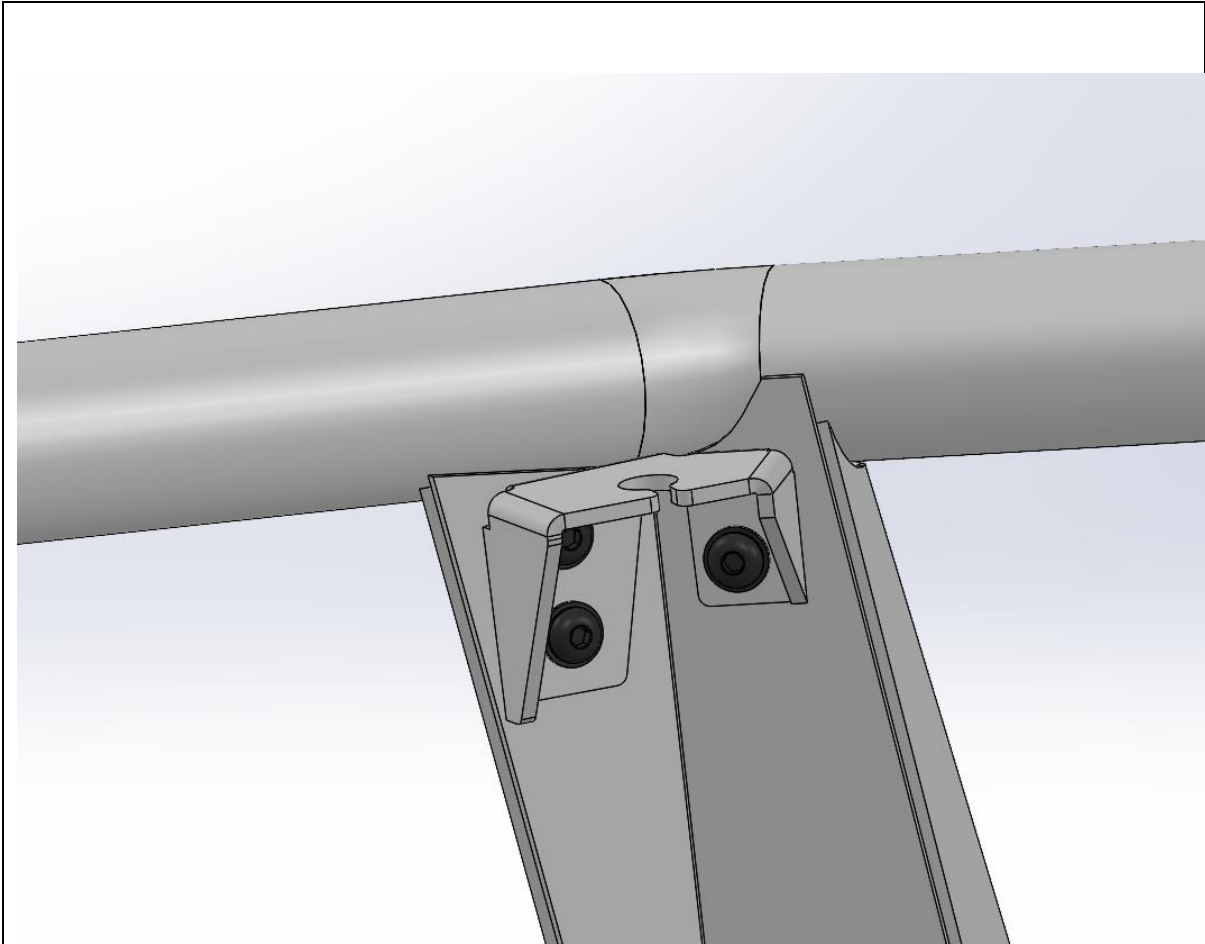

- 134. If fitting antenna to Toro bar, fit the antenna brackets to the M8 Threaded inserts in the uprights.
- 135. Tighten with 5mm Allen wrench
- 136. Fit Antenna to the bracket as per antenna manufacturer's instructions
- 137. Retain unused brackets for future use.

TOOLS REQUIRED

5MM Allen Key

FASTENERS

3x M8x20 Button Head Screw
3x M8 Black Flat Washer



138. Check all Fasteners are tight.
139. Re-Fit number plate to number plate flip.
140. Head Bush and Enjoy your newly protected Cruiser!

For contact details see www.offroadanimal.com