



Jeep Grand Cherokee WK2

MY2014-2021

Predator Bull Bar

IMPORTANT! – READ BEFORE INSTALLATION

- When installed in accordance with these instructions, the front protection bar does not affect the operation of the vehicles SRS airbags.
- This product must be installed exactly as per these instructions using only hardware supplied.
- Take a few moments to read instructions thoroughly before beginning work.
- In the event of damage to any component please contact OFFROAD ANIMAL to arrange repair/replacement of components.
- Do not use this product for any vehicle make or model other than that specified on these instructions.
- Do not remove labels from this product.
- This product and its fixings must not be modified in any way unless stated in these fitting instructions.
- The installation of this product is recommended for trained personnel.
- These instructions are correct at time of publication. OFFROAD ANIMAL cannot be held responsible for the impact of any changes subsequently made by the vehicle manufacturer. If you find something has changed please contact us to let us know!
- During installation it is the duty of the installer to check correct operation/clearances of all components.
- If Instructions are to be printed for reference in the workshop, it is recommended that they are printed in colour, for best legibility.
- Estimated install time: 6 hours

PARTS LISTING

IMPORTANT: Check all parts are present before beginning work! Contact OFFROAD ANIMAL if something is missing.

Main Parts – In the Box

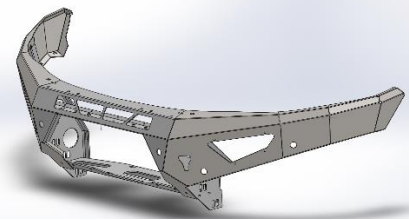
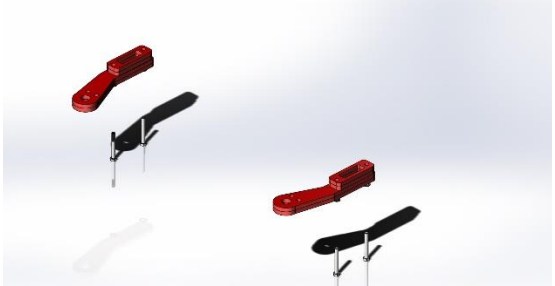
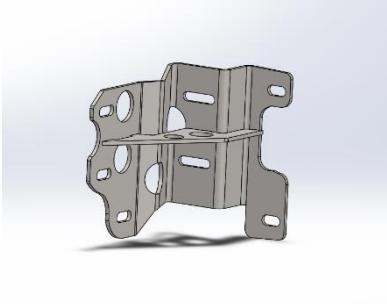
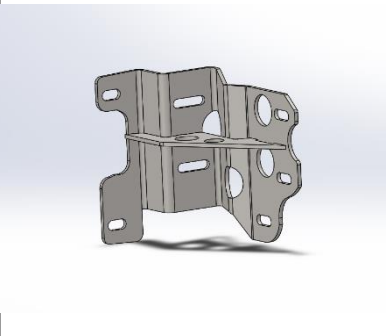
Qty	Part Number	Description	Image
1	FB-JGC-WK2-14-PR-ASM1	Wk2 Predator Weldment	
1	RP-JGC-WK2-11-ASM0	Recovery Points Wk2 (some customers may already have these)	
1	FB-JGC-WK2-14-PR-ASM2L	Impact Absorber wk2 LH	
1	FB-JGC-WK2-14-PR-ASM2R	Impact Absorber wk2 RH	

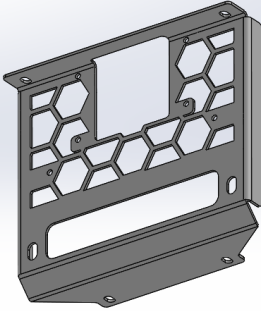
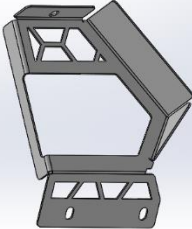
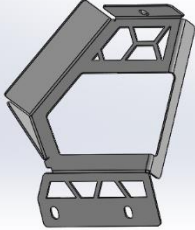
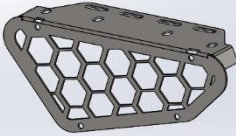
<p>1</p>	<p>M-0020</p>	<p>Wk2 Predator Centre Fairlead Mesh</p>	
<p>1</p>	<p>M-0015L</p>	<p>Dmax Predator Side Mesh LH</p>	
<p>1</p>	<p>M-0015R</p>	<p>Dmax Predator side Mesh RH</p>	
<p>1</p>	<p>M-002L</p>	<p>Light cover Mesh LH</p>	

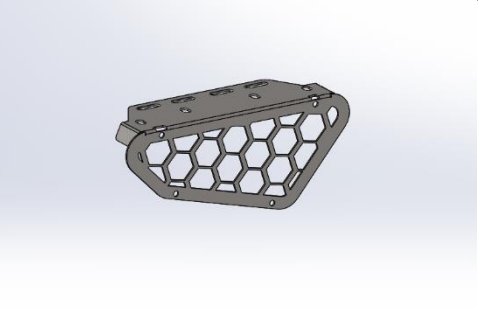
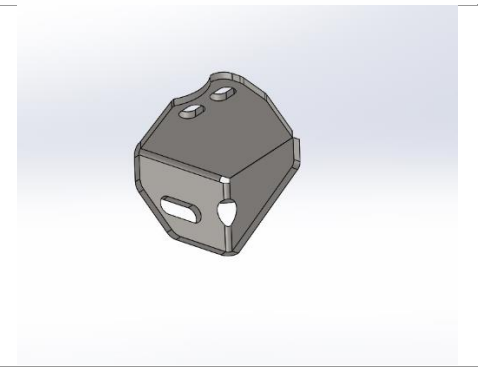
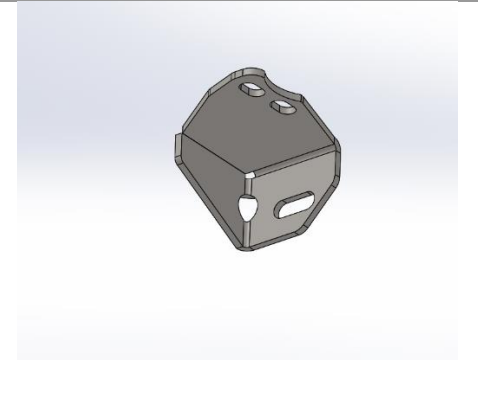
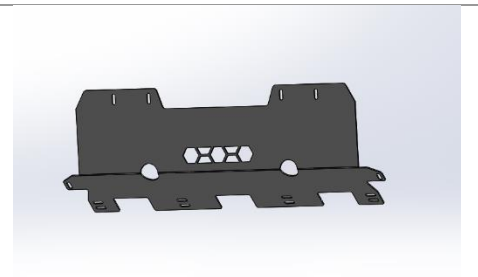
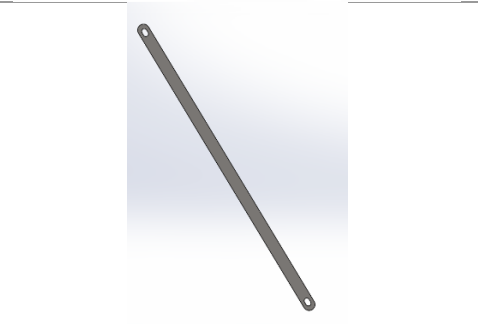
<p>1</p>	<p>M-002R</p>	<p>Light Cover Mesh RH</p>	
<p>2</p>	<p>B-0482L</p>	<p>Wk2 Lower gusset LH</p>	
<p>1</p>	<p>B-0482R</p>	<p>Wk2 Lower gusset RH</p>	
<p>1</p>	<p>U-0033</p>	<p>Wk2 Predator bash plate</p>	
<p>2</p>	<p>P-0165</p>	<p>Wk2 Radiator brace predator</p>	

1	B-0474	Acc mount Predator	
1	NPF-COM-SM-ASMO	Number plate flip Sml	
1	U-0038L If Vehicle equipped with Air suspension	Wk2 side under panel with Air suspension LH	
1	U-0038R If Vehicle equipped with Air suspension	Wk2 side under panel with Air suspension RH	
1	B-0087 If Vehicle equipped with Air suspension	Air Suspension Bracket	
1	FB-JGC-WK2-14-PR-ASM3L If Vehicle equipped with steel springs	Wk2 under panel No Air Suspension LH	

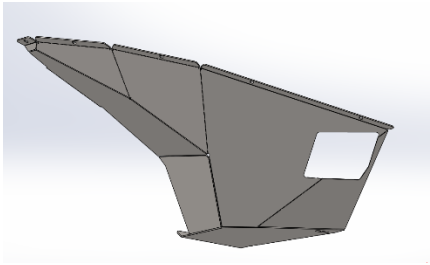
1	FB-JGC-WK2-14-PR-ASM3R If Vehicle equipped with steel springs	Wk2 under panel No Air Suspension RH	
----------	--	--------------------------------------	--

Small Parts – Contained in Small Parts Kit Bag

Qty	Part Number	Description
10	M8 FW Black Zinc	M8 Flat washer black zinc plate
6	M8 x 30 BHCS BZ	M8 x 30 Button Head Cap Screw, Black Zinc
8	M8 FN	M8 Flange Nut
14	M12 FW LHD	M12 Flat washer large heavy duty
6	M12 NY	M12 Nyloc Nut
22	M6x16 BHCS BZ	M6 x 16 Button Head Cap Screw, Black Zinc
22	M6 FW BZ	M6 Flat washer, Black Zinc
14	M6 FN	M6 Flange Nut
4	M10 FN	M10 Flange Nut
4	M10 FW	M10 Flat Washer
4	M10 x 50	M10 x 50 Hex Bolt, Zinc Plate
1	OFA-LOGO	OFFROAD ANIMAL METAL LOGO
1	Pinch Weld 2.8M	Pinch Weld Black 14mm x 9mm x 2.8M
2	M12 FN	M12 Flange Nut
8	M12x30	M12 x 30 Hex bolt 8.8
5	M6 FW MD	M6 Mud Guard Washer
5	M6 x 20	M6 x 20 Hex bolt 8.8
4	M8 x 16 BHCS BZ	M8 x 16 Button Head Cap Screw Black Zinc
4	M5 x 30 Pan	M5 x 30 Pan head screw
10	M6CN3MM	M6 Cage nut
2	M8 FW	M8 Flat washer
2	M8 x 25	M8 x 25 Hex bolt 8.8

TOOLS REQUIRED

The following tools will be required to install the product.

Hand Tools	Power Tools	Workshop Equipment
10mm Spanner 13mm Spanner 16mm Spanner 17mm Spanner 18mm Spanner 19mm Spanner 4mm Allen Key 5mm Allen Key 10mm Socket 13mm Socket 16mm Socket 17mm Socket 18mm Socket Ratcheting Socket Wrench Flat head screw driver or Pry Tool Side Cutters Phillips head screw driver	Air Hacksaw or angle Grinder	Masking tape Tape measure 6 inch Rule Adhesive silicone (with caulking gun) Razor blade(box cutter)

GENERAL WARNINGS

Take Care not to lose factory hardware, as some will be reused

Take care not to damage parking sensors

If ACC radar is not working as it should, stand side on the vehicle and see which way it's pointing. If pointing up or down adjust screws so it's pointing straight ahead.



1. First step is to remove the lower air damn fascia. To do this climb under your Jeep and remove all 7 quarter turn clips by hand. Two are tucked up high in each corner and 3 in the middle
2. Once they are removed pull the entire lower air damn away from Jeep by hand. You will not be reusing this part

TOOLS REQUIRED

None

FASTENERS

Discard

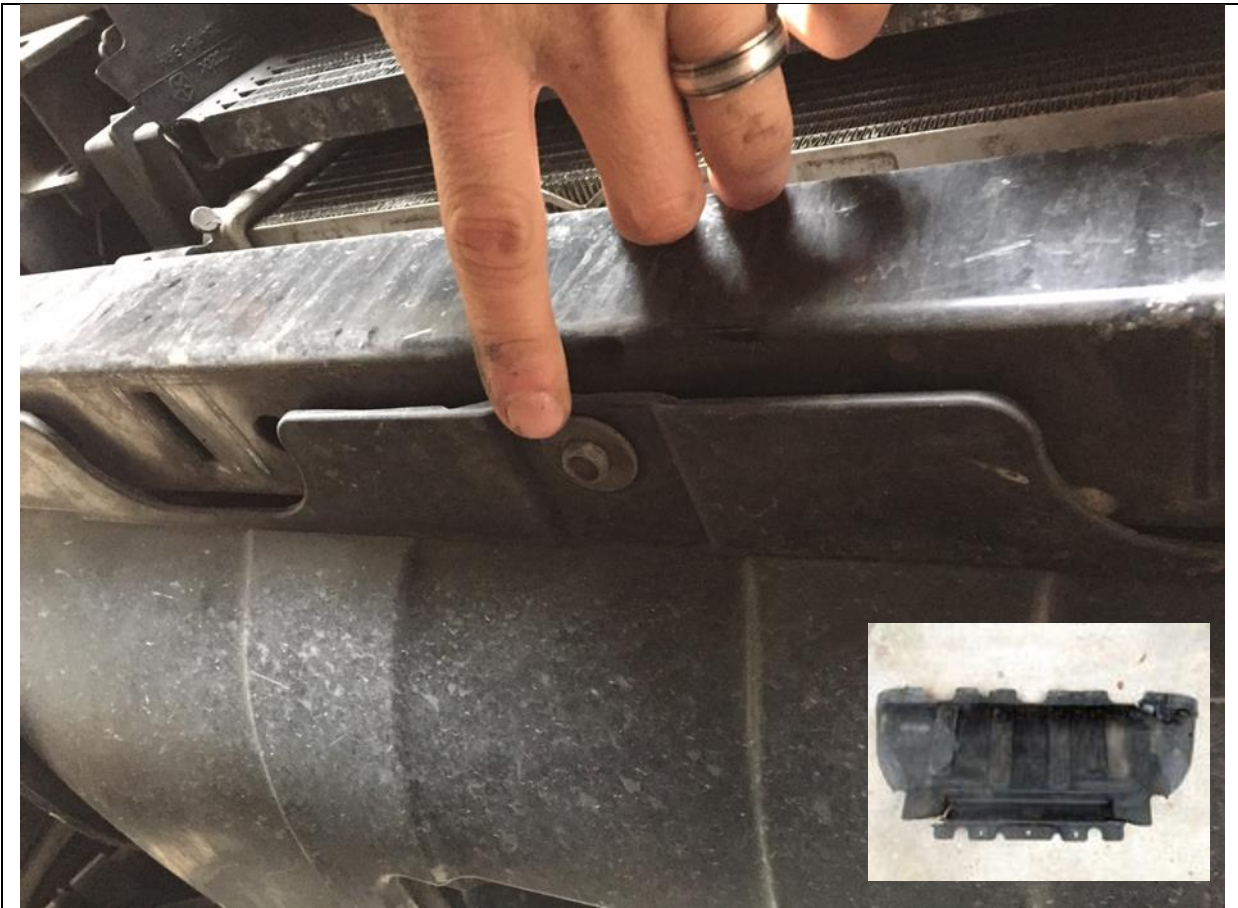

3. Remove factory Lower Radiator Cover. 3x M6 bolts on front and 2x M8 bolts on back. Use 10mm socket or spanner for front and 13mm for rear

TOOLS REQUIRED

10mm Socket or Spanner
13mm Socket or Spanner

FASTENERS

Retain for reuse



4. Remove factory tie down and or tow points

TOOLS REQUIRED

Socket set

FASTENERS

Discard fasteners



5. Stack Offroad Animal Tow points together as shown with M10 bolts and M10 flat washers.

TOOLS REQUIRED

FASTENERS

- M10x80 Hex bolts (4)
M10 Flat Washers (4)



6. Fit Offroad Animal Tow points as shown on LH and RH side with M10x80 bolts directly into frame of Jeep. Torque down bolts to 70 Nm

TOOLS REQUIRED

**16mm or 17mm Socket or
Spanner (depending on
supplier of bolts)**

FASTENERS

M10 x 80 (4)
M10 Flat washers (4)

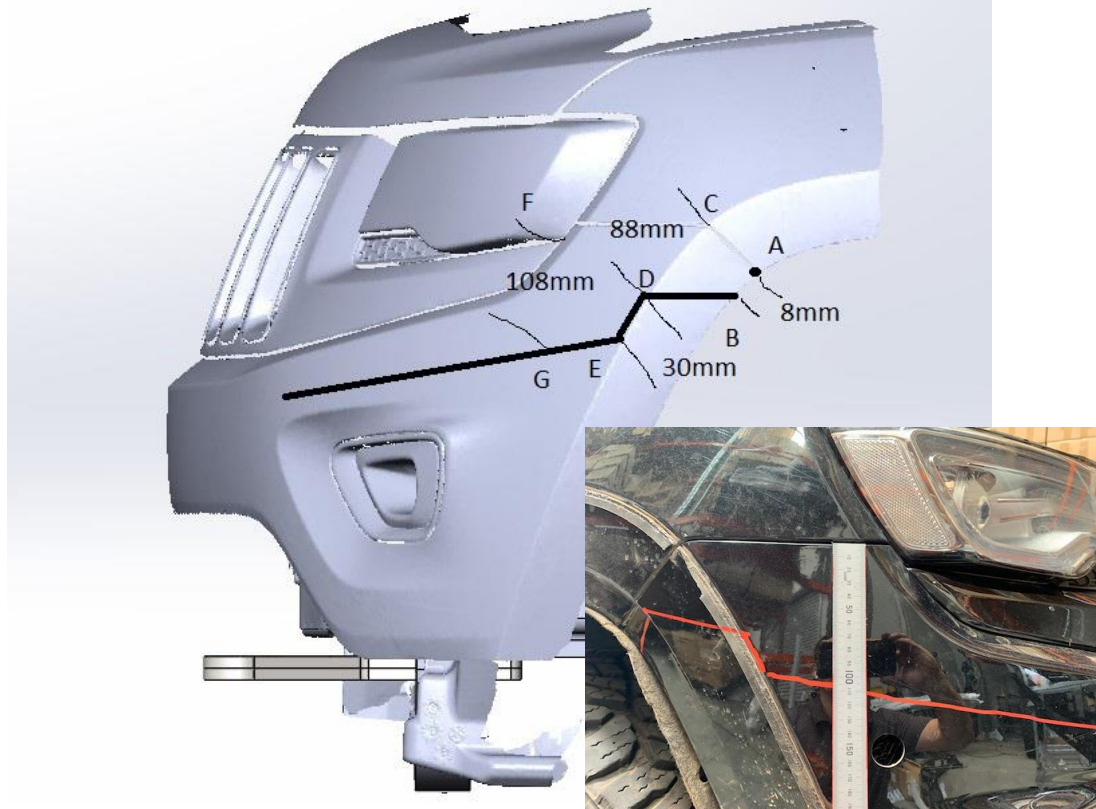

- 7. **This step is for marking up the bumper cut on a 2014-2016**
- 8. **Skip to step 24 for 2017-2020**
- 9. **These cuts will not work on the following trim levels, Summit, High Altitude, and S limited.**
- 10. Start by removing the factory flare.
- 11. Measure down from point A to point B, 8mm, put a mark
- 12. Measure down from point C to point D, 88mm and put a mark here.
- 13. Measure down from point D to point E along the mold line in bumper 30mm
- 14. Measure down from point F to point G 108mm, see real photo above for position.
- 15. Using a Felt Pen or paint pen, Join Points B to D, then D to E, then E to G.

TOOLS REQUIRED

Felt pen or paint pen

FASTENERS



16. This step shows a fully marked side, repeat for other side

TOOLS REQUIRED

FASTENERS

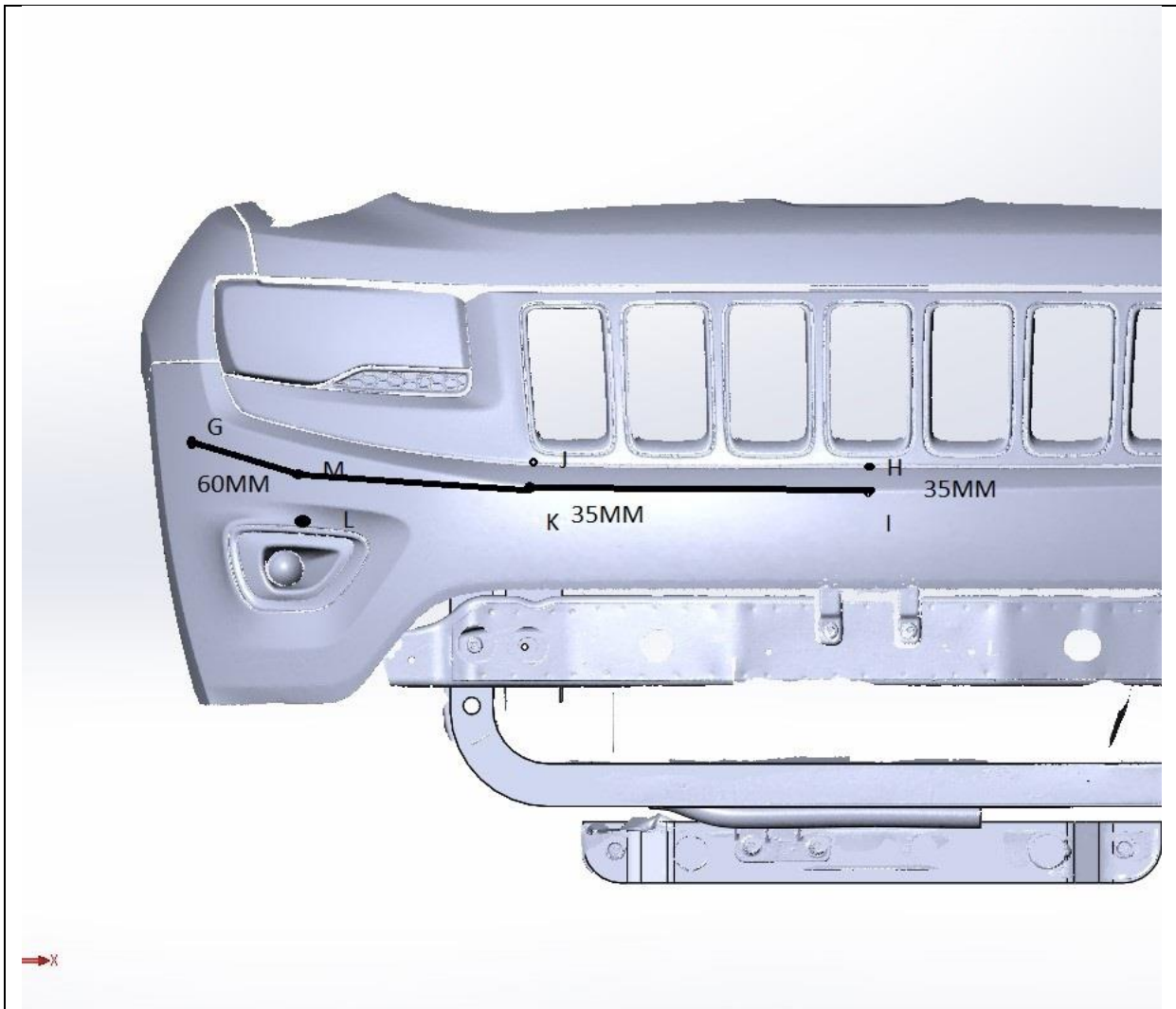

17. Point H is the join between the grill and the point at which the bumper starts to slope down, and right in the middle of the bumper from left to right. Measure down 35mm on that sloping face and put a mark.
18. Point J is the point at which the bumper and grill meet at the edge of the Grill slot, measure down 35mm and this is point K, put a mark there.
19. Point L is the point where the bumper and fog light housing meet and **left to right directly above the globe of the light not the housing**. Measure up 60mm and this is Point M
20. Mark a line with a felt pen or paint pen, Join Point I to Point K, Point K to point M and Point M to Point G.
21. Repeat for other side.

TOOLS REQUIRED

Felt pen or paint pen

FASTENERS



22. These photos will better portray how to measure steps 18 and 19

TOOLS REQUIRED

Felt pen or paint pen

FASTENERS



23. Use masking tape to mark out the cut lines. Put the masking tape above the cut lines to protect the portion of the bumper that will stay.

TOOLS REQUIRED

FASTENERS

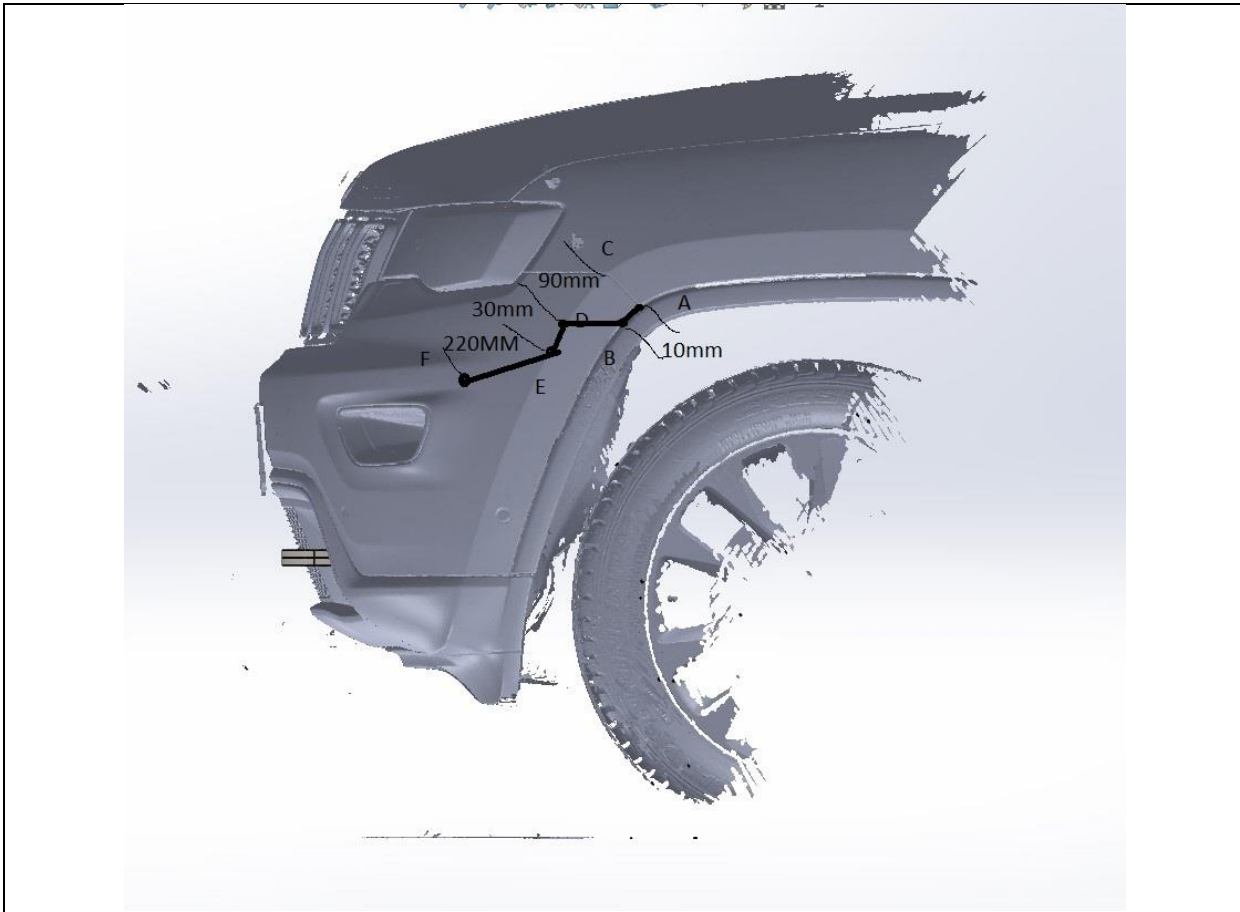

- 24. The following steps are for cutting a bumper MY17-MY21**
25. Remove factory flare
 26. Measure down from point A 10mm to point B and mark this point.
 27. Measure down from point C 90mm along the mold line and this is point D (mark this point)
 28. Follow the mold line a further 30mm down to point E and mark this point.
 29. Point F is right at the edge of the impression for the fog light indent in the bumper roughly 220mm from point E
 30. Draw a line with a felt pen or paint pen B to D, then D to E, then E to F.
 31. Repeat for the other side.

TOOLS REQUIRED

Felt pen or paint pen

FASTENERS



32. Point G is the centre of the bumper from left to right and the top most mold line
33. Measure down 55mm and mark point H.
34. Point I is the edge of the grill on the top mold line, measure down 55mm and mark point J
35. Draw a line from point H to J, then J to F from the previous step.
36. Repeat for the other side

TOOLS REQUIRED

Felt pen or paint pen

FASTENERS



37. Use masking tape above the cut line to protect the bumper section you're going to keep

TOOLS REQUIRED

Masking tape

FASTENERS



38. Next step is to remove the rest of the front bumper. Start with bonnet/hood open and pry out two clips shown with trim tool or flat head screw driver

TOOLS REQUIRED

Trim tool or flat head screw driver

FASTENERS

Retain factory clips



- 39. At the wheel arch on both sides you will need to pry out 2 plastic rivets. You can also drill out the centre of the rivet if you're struggling to pry it out.
- 40. Remove screw shown with 10mm socket or spanner

TOOLS REQUIRED
Trim tool, or flat head screw driver
10mm socket or spanner

FASTENERS
Discard plastic rivets



41. Pull factory flare away from bumper, using a flat head screw driver release at least 2 of the push in clips on top edge being careful not to break them as you pull the flare away from the body

TOOLS REQUIRED

Flat head screwdriver

FASTENERS



42. Pull the edge of the bumper away from the body

TOOLS REQUIRED

FASTENERS



43. Lifting the top section ever so slightly you can release clips holding in the top section and pull the remainder of the bumper away

TOOLS REQUIRED

FASTENERS



44. Pull out 2 plastic Christmas tree clips holding foam in

TOOLS REQUIRED

Trim tool, or flat head screw driver

FASTENERS

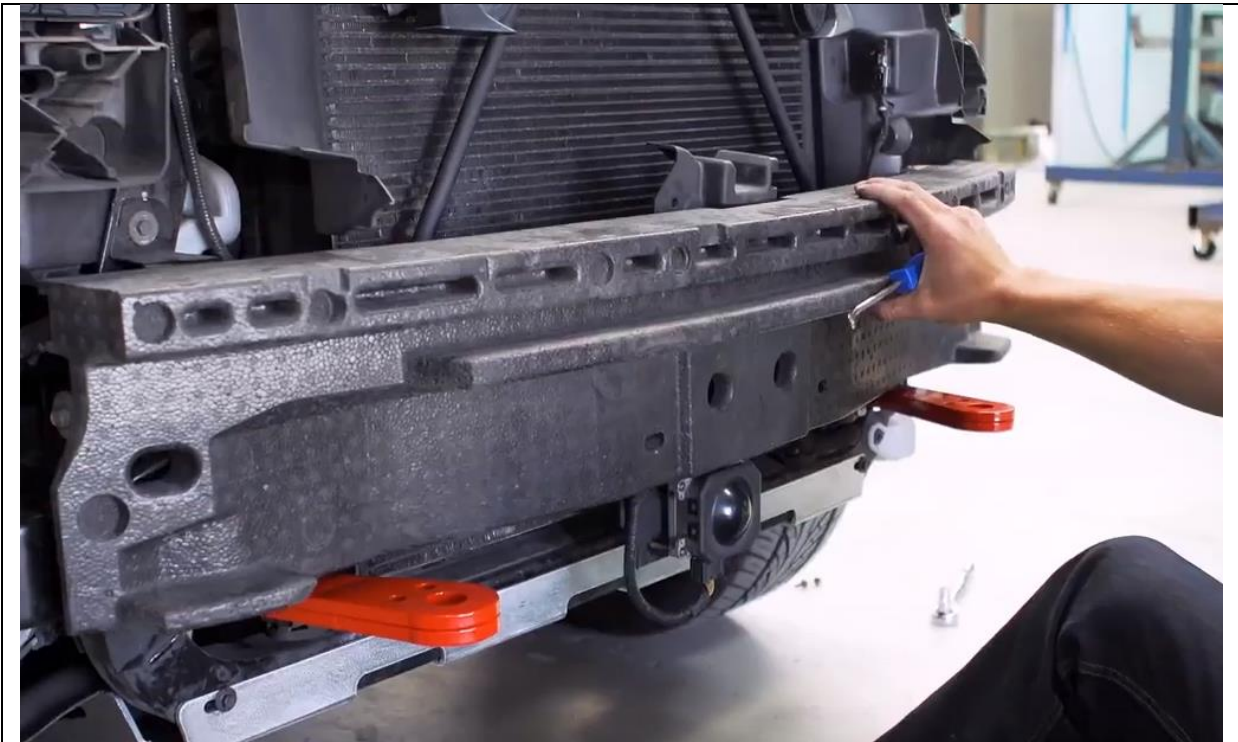

45. Pull foam insert off

TOOLS REQUIRED

FASTENERS

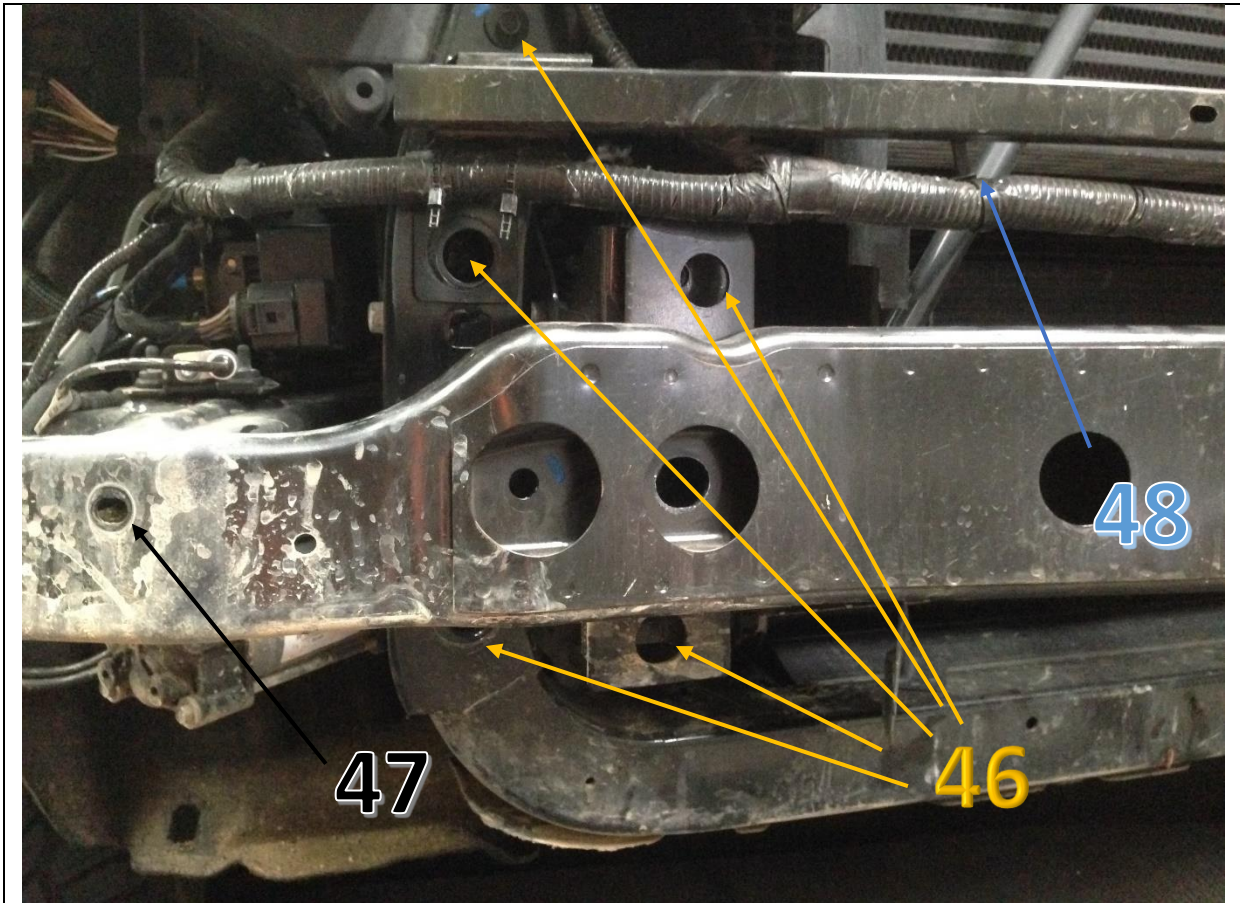

- 46. Remove bumper reinforcement by removing 8 x M8 bolts (4 per side with 13mm tool) and 2 x M6 bolts with 10mm tool
- 47. If equipped with air suspension remove 2 flange nuts holding compressor onto bumper reinforcement
- 48. Using trim tool or similar remove all loom securing keepers holding wiring onto bumper reinforcement

TOOLS REQUIRED
10mm spanner or socket
13mm spanner or socket
Trim tool or flat head screw driver

FASTENERS
 Retain all fasteners, some will be reused



49. If Adaptive cruise control is fitted, unplug loom and pull sensor off posts

TOOLS REQUIRED

FASTENERS

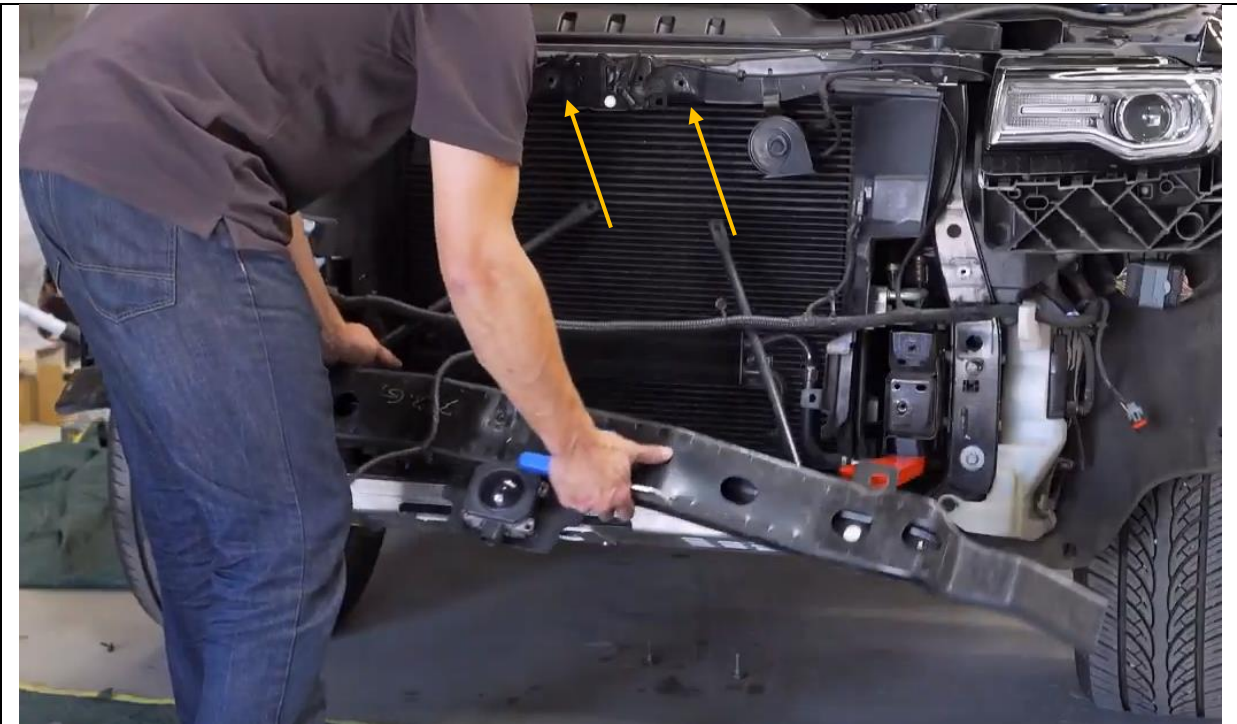

50. Remove 2x screws with 13mm tool holding round support bars from top of bonnet support then remove entire reinforcement bar.

TOOLS REQUIRED

13mm socket or spanner

FASTENERS

Retain for reuse



51. Cut tab off shown in picture from both sides, you can bend it back and forth a few times and remove by hand

TOOLS REQUIRED

Angle grinder or air hacksaw
or sawzall

FASTENERS



- 52. If vehicle is fitted with Air Suspension, fit Air suspension bracket as shown.
- 53. If no air suspension fitted you can discard this bracket or send it back to Offroad Animal and we'll send you a hat

TOOLS REQUIRED

- 15mm spanner or socket**
- 13mm spanner or socket**

FASTENERS

Reuse Factory hardware

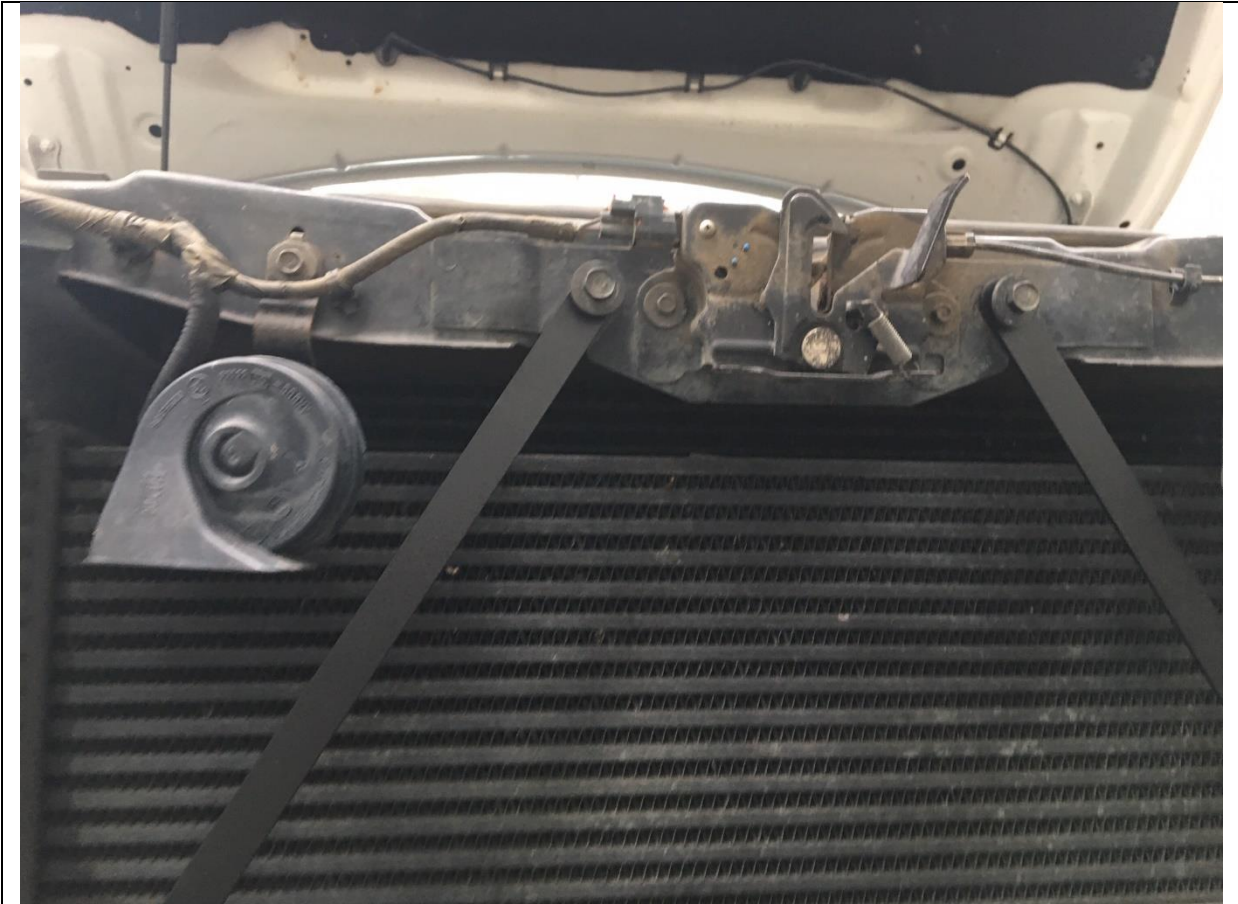

54. Fit radiator braces as shown with factory bolts

TOOLS REQUIRED

15mm spanner or socket
13mm spanner or socket

FASTENERS

Reuse Factory hardware



55. If factory parking sensors are present on the vehicle you'll need to remove the sensor from each housing and pry the housing off the bumper with a trim tool or flat head screw driver

TOOLS REQUIRED
Pry tool or flat head screw driver

FASTENERS



56. Clean the front face of the sensor mount and when dry apply a healthy amount of adhesive silicone to the front face of each sensor mount

TOOLS REQUIRED
Adhesive Silicone

FASTENERS



- 57. Press the sensor housing on the inside of the bull bar (ensure clean face on bull bar as well)
- 58. Orientate housing so sensor will still be able to fit in with wires hanging out the side
- 59. Repeat for other 5 sensors

TOOLS REQUIRED

Adhesive Silicone

FASTENERS



- 60. Using an angle grinder, air hacksaw or jigsaw, trim the bumper
- 61. Refit bumper to car

TOOLS REQUIRED

Air hacksaw, jigsaw or angle grinder

FASTENERS



62. Fit cage nuts to the bar as shown. You can often just push them in by hand, otherwise use a flat head screwdriver. You may need to use the screwdriver to open the legs of each nut from underneath

TOOLS REQUIRED

Flat head screw driver

FASTENERS

M6 Cage nuts (10)



63. After at least an hour push the sensors into their housings. Make sure the housings are set, if the weather is cold you may need to wait longer.

TOOLS REQUIRED

FASTENERS



64. If fitting a light bar to the bull bar, do so now with provided hardware.

TOOLS REQUIRED

5mm Allen key

FASTENERS



65. Fit a small section of pinch weld as shown

TOOLS REQUIRED

FASTENERS



- 66. Install the chassis brackets as shown with existing hardware
- 67. Repeat for either side
- 68. Measure between mounts and ensure you have about 2-5mm wider distance than corresponding mounts on the bull bar.
- 69. Torque bolts to 30 Nm

TOOLS REQUIRED

13mm socket

FASTENERS



70. With the help of a friend or lifting table (guess which one is easier, no it's not with your friend) lift the bar on top the mounts and hold up with M12x 30 hex bolts, flat washers and nuts

TOOLS REQUIRED

FASTENERS

- M12 x 30 (2)
- M12 FW LHD (2)
- M12 FN (2)



71. Fit the rest of the M12 x 30 bolts, flat washers and Nyloc nuts, leave loose for now.

TOOLS REQUIRED

FASTENERS
M12 x 30 (4)
M12 FW LHD (4)
M12 NY (4)



- 72. Push the bar up to the cut edge and as far back as it will go and still clear the bumper.
- 73. If you want you can put more pinch weld on the edge of the bar but we don't think it's required.
- 74. Mark the flare in line with the bar
- 75. Trim flare

TOOLS REQUIRED

Felt pen or paint pen
Angle grinder

FASTENERS



- 76. Once the bar is in position, fit the lower gussets as shown through the bar with M12 x 30 and through tow points with M10x50 hex bolts, washers and flange nuts
- 77. Torque all M12 bolts too 100 Nm and M10 to 60 Nm
- 78. Fit bottom of radiator brace to inside of mounts with M6 hardware

TOOLS REQUIRED
10mm spanner or socket

FASTENERS
 M12 x 30 (2)
 M12 FW LHD (2)
 M12 NY (2)
 M10 x 50 (4)
 M10 FW (4)
 M10 FN (4)
 M6 x 20 (2)
 M6 FW (2)
 M6 FN (2)



79. Fit Radar to ACC bracket as shown MY 14-MY16 with supplied M5 screws.

TOOLS REQUIRED

Phillips head screw driver
Trox bits

FASTENERS

M5x30 Pan (4)

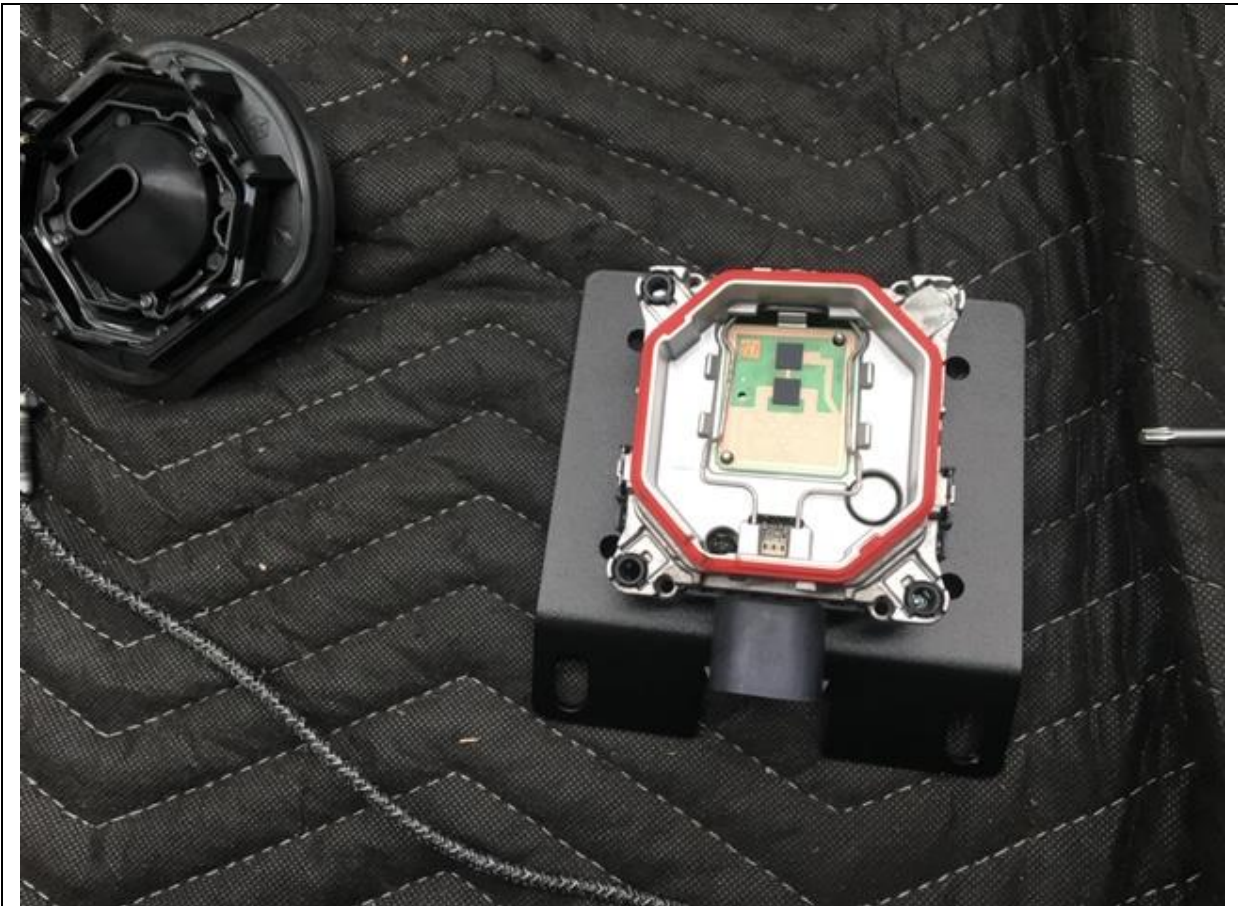

80. If My17+ model you'll need to remove the front face of the radar to get to the fasteners, and fit to ACC bracket

TOOLS REQUIRED

Phillips head screw driver
Trox bits

FASTENERS

M5x30 Pan (4)



- 81. If fitting a winch to the bar, fit fair lead to centre mesh panel now
- 82. Fit number plate flip and number plate as well

TOOLS REQUIRED

Depends on fasteners supplied with fairlead
10mm spanner

FASTENERS

M6 x 20 (2)
M6 FW (2)
M6 FN (2)



- 83. If fitting winch, do so now by angling it into the front of the bar as shown.
- 84. Secure with hardware supplied with winch
- 85. Ensure you can reach control box with hand lead
- 86. If you get a winch that doesn't allow the control box to mount on the top of it, or has the opening facing up you'll need to relocate the control box to the side of the winch.

TOOLS REQUIRED

16mm socket

FASTENERS

Supplied with winch



87. Fit ACC mount with Radar to centre mesh panel with M6 hardware

TOOLS REQUIRED

4mm Allen Key

FASTENERS

M6 x 16 BHCS BZ (4)
M6 FW BZ (4)
M6 FN (4)



- 88. Fit centre mesh panel to bar as shown. Use M8 hex nuts on bottom and button head cap screws on the top.
- 89. Now is the time to align the radar. Standing side on and front on ensure the radar is facing directly forward. You can adjust the mounting screws to achieve this.

Special Note: Offroad Animal will not be held responsible for poorly aligned radars. They work as long as they are facing forward, not left or right, or up or down.

TOOLS REQUIRED

- 13mm Socket
- 5mm Allen Key

FASTENERS

- M8x 16 BHCS BZ (2)
- M8 FW BZ (2)
- M8 FN (4)
- M8x25 (2)
- M8 FW (2)



- 90. Fit middle side mesh as shown with M8 x 16 BHCS and washer. Note the side flange of the mesh panel goes behind the inner lip of the bull bar. Leave the 2 bottom bolts empty for now
- 91. Repeat for other side

TOOLS REQUIRED
5mm Allen Key

FASTENERS



92. Your factory fog lights do not fit, sorry. But you can fit driving lights in the wings which is much better. 2 cube lights per or one 6-8" single row LED light bar. See above showing a single row 8" Offroad Animal light. Or you can leave this area blank
93. Repeat for other side

TOOLS REQUIRED

FASTENERS



- 94. Fit mesh panel to bar from behind with M6 hardware
- 95. Repeat for other side

TOOLS REQUIRED

4mm Allen Key

FASTENERS

M6 x 16 BHCS BZ (8)
M6 FW BZ (8)
M6 FN (8)



96. Fit bash plate as shown with M8 hardware through bash plate, mesh panel and into winch cradle.

TOOLS REQUIRED

5mm Allen Key

FASTENERS

M8 x 30 BHCS BZ (4)

M8 FW BZ (4)

M8 FN (4)



97. If fitting optional stealth hoop and light, fit light to hoop as shown.

TOOLS REQUIRED

FASTENERS

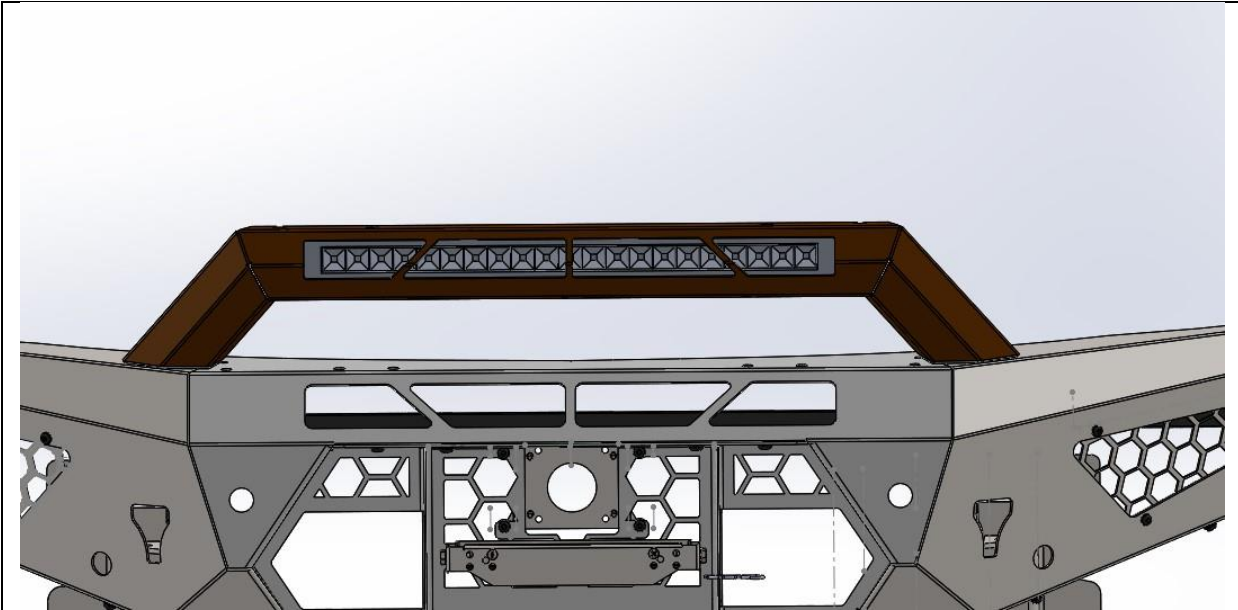

98. Fit hoop to top of bar and secure with Supplied M10 hardware from hoop box

TOOLS REQUIRED

FASTENERS



99. Fit lower factory M6 bolts through bash plate into cross member. Do not over-torque these

TOOLS REQUIRED
10mm spanner or socket

FASTENERS
Factory bolts



100. Fit under panels as shown with M6 along top edge and M8x 30 bolts. Trim Felt wheel well liner with razor blade so it tucks neatly behind the under panel which will hold it in place.

TOOLS REQUIRED

4mm Allan Key
13mm spanner
Razor blade

FASTENERS

M6x16 BHCS BZ (10)
M6 FW BZ (10)
M8 x 30 hex (2)
M8 FW (2)
M8 FN (2)



<p>101. Fit the logo plate (you bloody better do it or we'll find out and hunt you)</p> <p>102. Fit compliance plate under bash plate so you can show coppers if they want to see it.</p> <p>103. You're done unless you need to wire lights in, then you should have been doing that already.</p> <p>Enjoy</p>	<p>TOOLS REQUIRED</p>
	<p>FASTENERS</p>