



FORD RANGER PX2

MY2015-2018

PREDATOR FRONT BAR

IMPORTANT! – READ BEFORE INSTALLATION

- When installed in accordance with these instructions, the front protection bar does not affect the operation of the vehicles SRS airbags.
- This product must be installed exactly as per these instructions using only hardware supplied.
- Take a few moments to read instructions thoroughly before beginning work.
- In the event of damage to any bar component please contact OFFROAD ANIMAL to arrange repair/replacement of components.
- Do not use this product for any vehicle make or model other than that specified on these instructions.
- Do not remove labels from this product.
- This product and its fixings must not be modified in any way unless stated in these fitting instructions.
- The installation of this product is recommended for trained personnel.
- These instructions are correct at time of publication. OFFROAD ANIMAL cannot be held responsible for the impact of any changes subsequently made by the vehicle manufacturer. If you find something has changed please contact us to let us know!
- During installation it is the duty of the installer to check correct operation/clearances of all components.
- If Instructions are to be printed for reference in the workshop, it is recommended that they are printed in colour, for best legibility.

PARTS LISTING

IMPORTANT: Check all parts are present before beginning work! Contact OFFROAD ANIMAL if something is missing.

Main Parts – In the Box

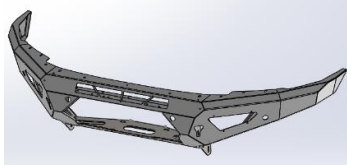
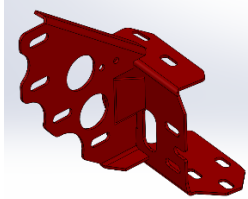
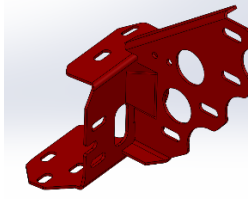
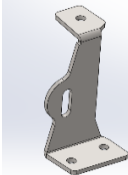
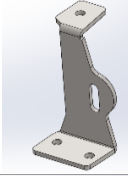
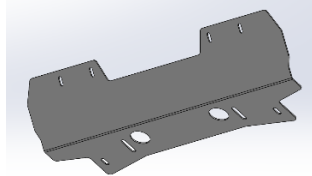
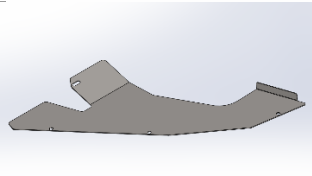
Qty	Part Number	Description	Image
1	FB-FRA-PX2-15-PR-ASM1	Ford Ranger PX2 Predator Bar Weldment	
1	FB-FRA-PX-11-PR-ASM2R	IMPACT ASSY PREDATOR PX RANGER	
1	FB-FRA-PX-11-PR-ASM2L	IMPACT ASSY PREDATOR PX RANGER	
1	B-0082L	PX CHASSIS BRKT GUSSET	
1	B-0082R	PX CHASSIS BRKT GUSSET	
1	U-0010	PX Ranger Bash Plate	
1	U-0003L	px under panel	

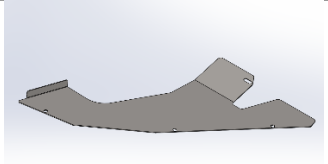
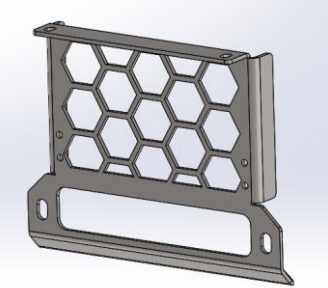
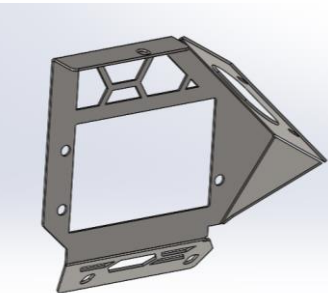
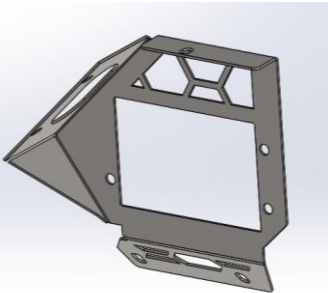
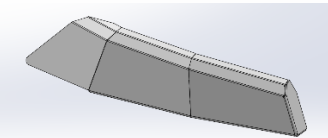
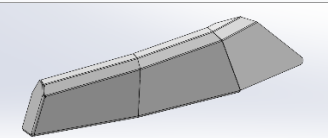
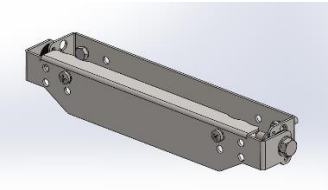
1	U-0003R	px under panel	
1	M-0004	PX2 Mesh Fairlead Mount	
1	M-0003L	PX2 Mesh Infill Panel LHS	
1	M-0003R	PX2 Mesh Infill Panel RHS	
1	B-0083R	PX2 HEADLIGHT INFILL	
1	B-0083L	PX2 HEADLIGHT INFILL	
1	B-0216	Ranger Winch control box bracket	
1	NPF-COM-SM-ASM0	Number Plate Flip Assy Small	

<p>1</p>	<p>M-0002R</p>	<p>Light Cover Mesh</p>	
<p>1</p>	<p>M-0002L</p>	<p>Light Cover Mesh</p>	
<p>1</p>	<p>B-0186L</p>	<p>Fog Lamp Bracket - Ranger PX</p>	
<p>1</p>	<p>B-0186R</p>	<p>Fog Lamp Bracket - Ranger PX</p>	

Small Parts – Contained in Small Parts Kit Bag

Qty	Part Number	Description
16	M6 FLANGE NUT	Flange Nut, M6x1 G8.8 ZP
22	M6x16 BHCS BLACK ZINC	SCREW, BUTTON HEAD CAP, M6X16X1 GR12.9 BLACK ZP
6	M6CN3MM	CAGE NUT M6x2.6-3.5
20	M6 FLAT WASHER BLACK ZINC	M6 FW BLACK ZP
20	M8 FLANGE NUT	Flange Nut, M8x1.25 G8.8 ZP
14	M8 FLAT WASHER- BLACK ZINC	M8 FW- BLACK ZINC
10	M8 X 16 BHCS BZP	SCREW, BUTTON HEAD CAP, M8X16X1.25 GR12.9 BLACK ZP
6	M8X20	Bolt Hex, M8X20X1.25, GR8.8 ZP
6	M8 FLAT WASHER	M8 FW
4	M8 X 20 BHCS BLACK ZINC	SCREW, BUTTON HEAD CAP, M8X20X1.25 BLACK ZP
20	M10 x 30	Bolt Hex, M10X30x[1.5], GR8.8 ZP
30	M10 Flat Washer	M10 FW
8	M10 NYLOC	NYLOC SELF LOCKING NUT, ST STL A2 ISO
12	M10 FLANGE NUT	Flange Nut, M10x1.5 G8.8 ZP
2	M10X20 BHCS	SCREW, BUTTON HEAD CAP, M10X20X1.5 GR12.9 ZP
8	M12X30	Bolt Hex, M12X30x1.75, GR8.8 ZP
8	M12 Nyloc nut	M12 NYLOC NUT
16	M12 FW LHD	M12 FW Large Heavy Duty
8	M5 FLANGE NUT	Flange Nut, M5x0.8 G8.8 ZP
8	M5X15 PAN	SCREW, PAN HEAD PHILLIPS, M5X15X0.8 GR4.6 ZP
4	FB-FRA-PX-19- PR-ASM3	PX Ranger - Sensor Cover
2	P-0072	Predator Bash Plate Shim

TOOLS REQUIRED

The following tools will be required to install the product.

Hand Tools	Power Tools	Workshop Supplies
Metric Socket Set 8-19mm Socket Extension Bar Metric Spanner Set 10-19mm Torx Drivers T25-T30 Hex (Allen) Key Set 4-8mm Trim Puller Tool Flat Blade Screwdriver set Phillips Head Screwdriver set Utility Knife	Electric Drill 6mm Drill Bit Air Hacksaw or Angle Grinder (Optional for Integrated control box winch fitment) Electric/Air Impact Driver (Optional)	Double Sided Adhesive Tape Panel Stand or Soft Blanket

WORKSHOP SAFETY

It is the responsibility of the installer to always complete works in a safe manner. Make sure the following safety equipment is available and precautions are observed whilst fitting this product.

<p>Hearing Protection</p> 	<p>Always wear ear protection when using power tools.</p>
<p>Eye Protection</p> 	<p>Ensure eye protection is always worn when cutting or drilling.</p>
<p>Manual Handling</p> 	<p>Do not attempt to lift bar assemblies or rock sliders on your own.</p> <p>Always use two people to lift or use mechanical Lifting aid such as hydraulic lifting trolley.</p>
<p>Vehicle Support</p> 	<p>Always ensure vehicle is properly supported when working on it. Do not attempt to fit products whilst suspension work is being carried out. Do not work under a vehicle supported only by a jack.</p>



1. Open Bonnet of Vehicle
2. Remove 5x plastic push rivets by levering center section upwards using flat bladed screwdriver or trim tool, as shown.

TOOLS REQUIRED

Flat Blade Screwdriver or
Trim Tool

FASTENERS

5x Plastic Push Rivet

Retain for Reassembly

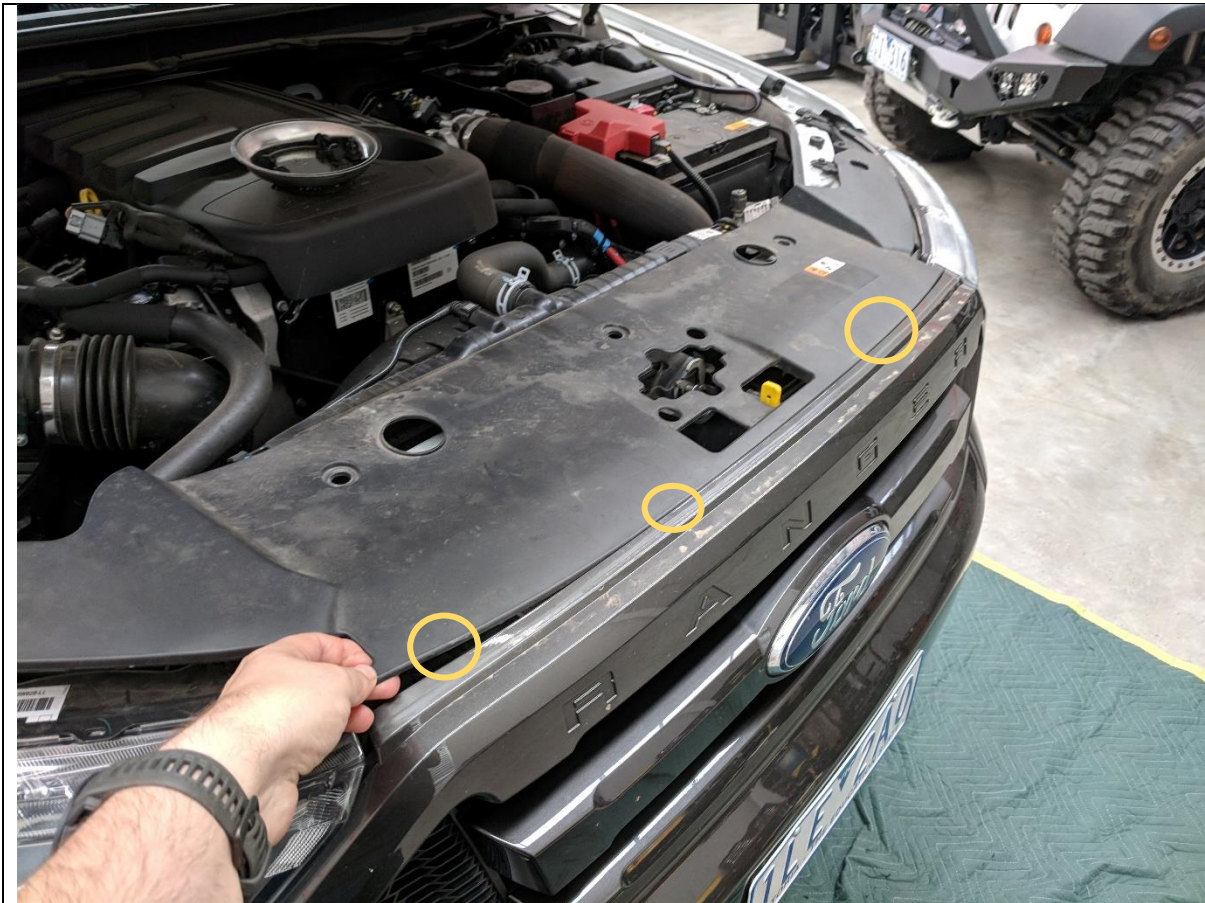

3. Carefully lift up plastic top shroud trim to unfasten concealed plastic clips securing trim to grille.
4. A Trim tool can be used to assist if required. Take care not to mar the finish of grille if tool is used.
5. Remove shroud and place aside

TOOLS REQUIRED

Trim Tool

FASTENERS

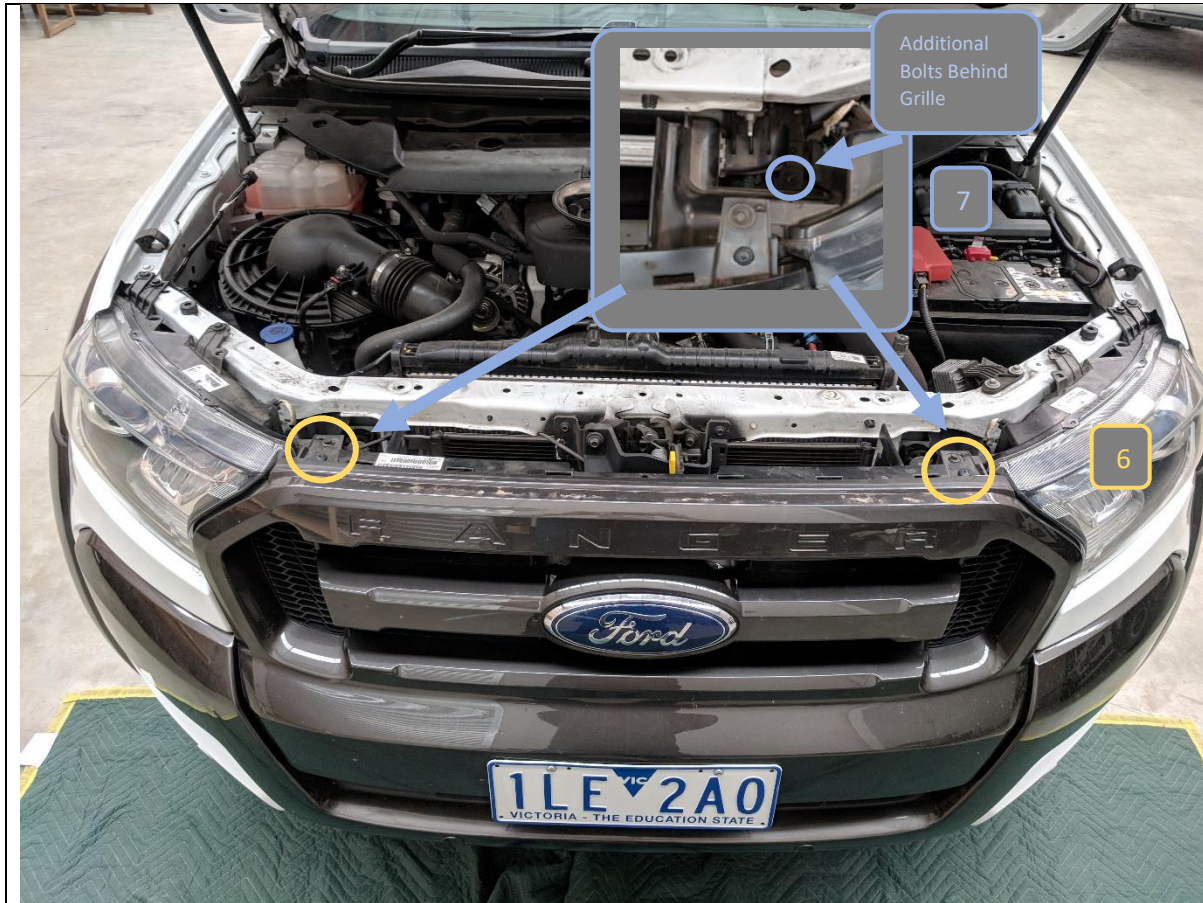

- 6. Remove Bolts securing the radiator grille using 10mm socket.
- 7. There are 2 bolts, one each side, recessed behind the grille that will require an extension bar to reach

TOOLS REQUIRED

10mm Socket
Extension Bar

FASTENERS

4x 10mm head flanged bolts.
Retain for reassembly

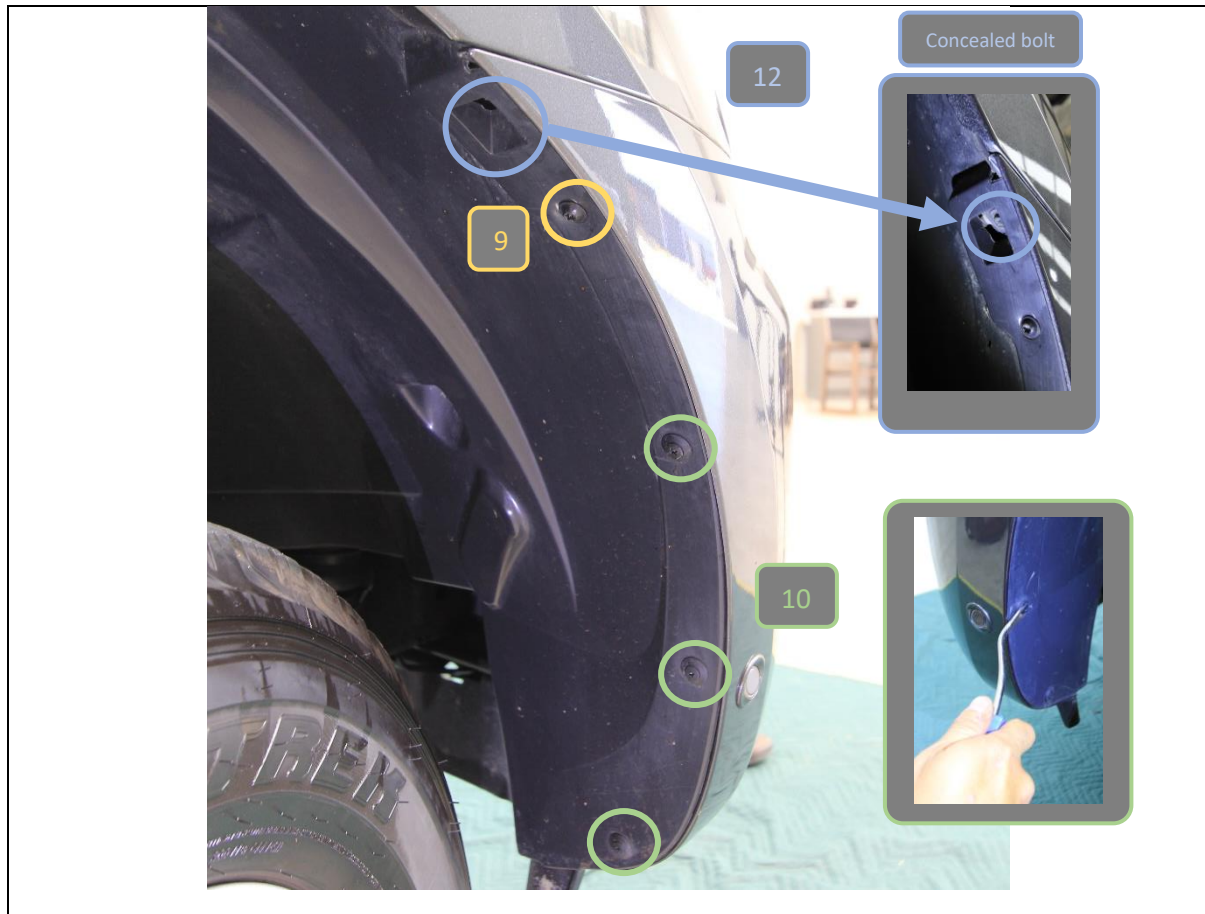

8. In the wheel arch remove the fasteners securing inner wheel arch liner to the bumper.
9. Remove Torx Screw with T30 Torx Driver.
10. Remove scrivets by using trim tool to prize out center section of rivet.
11. Remove concealed bolt with 8mm Socket.

TOOLS REQUIRED

10mm Socket
Extension Bar

FASTENERS

6x Scrivet
2x T30 Torx Screw
2x 8mm head Bolt

Discard



12. Remove the 6x Bolts securing lower bumper to the support brackets behind, using 8mm socket.
13. The bolts fastening the lower valance to the bumper do not need to be removed.

TOOLS REQUIRED

8mm Socket
Extension Bar

FASTENERS

6x 8mm head flanged bolts.
Discard



<p>14. Starting at the headlamp firmly but carefully pull the grille away from the bumper to release the clips.</p> <p>15. As the clips release move the pressure toward the opposite side, simultaneously on the top and bottom edge of grille until the next clip releases. Continue until all clips are free.</p>	<p>TOOLS REQUIRED</p>
<p>16. Carefully lift of grille once free and place on a non marking surface.</p>	<p>FASTENERS</p>

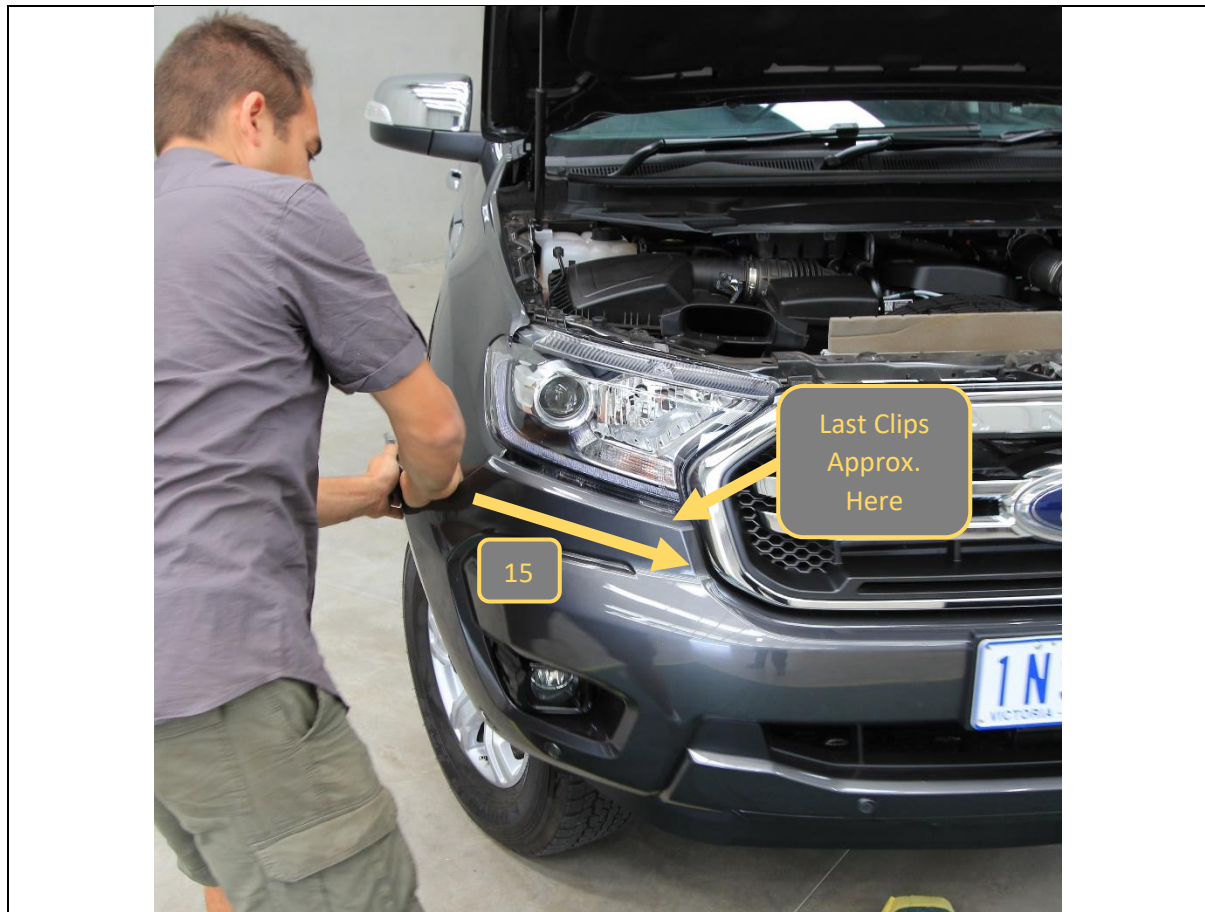

17. Starting at the wheel arch firmly but carefully pull the bumper away from the panel to release the clips.
18. As the clips release move the pressure toward the center of the car until the next clip releases. Continue until all clips on each side are free. The final clips are located underneath the headlight.
19. Repeat clip release on both sides of the bumper.

TOOLS REQUIRED

FASTENERS

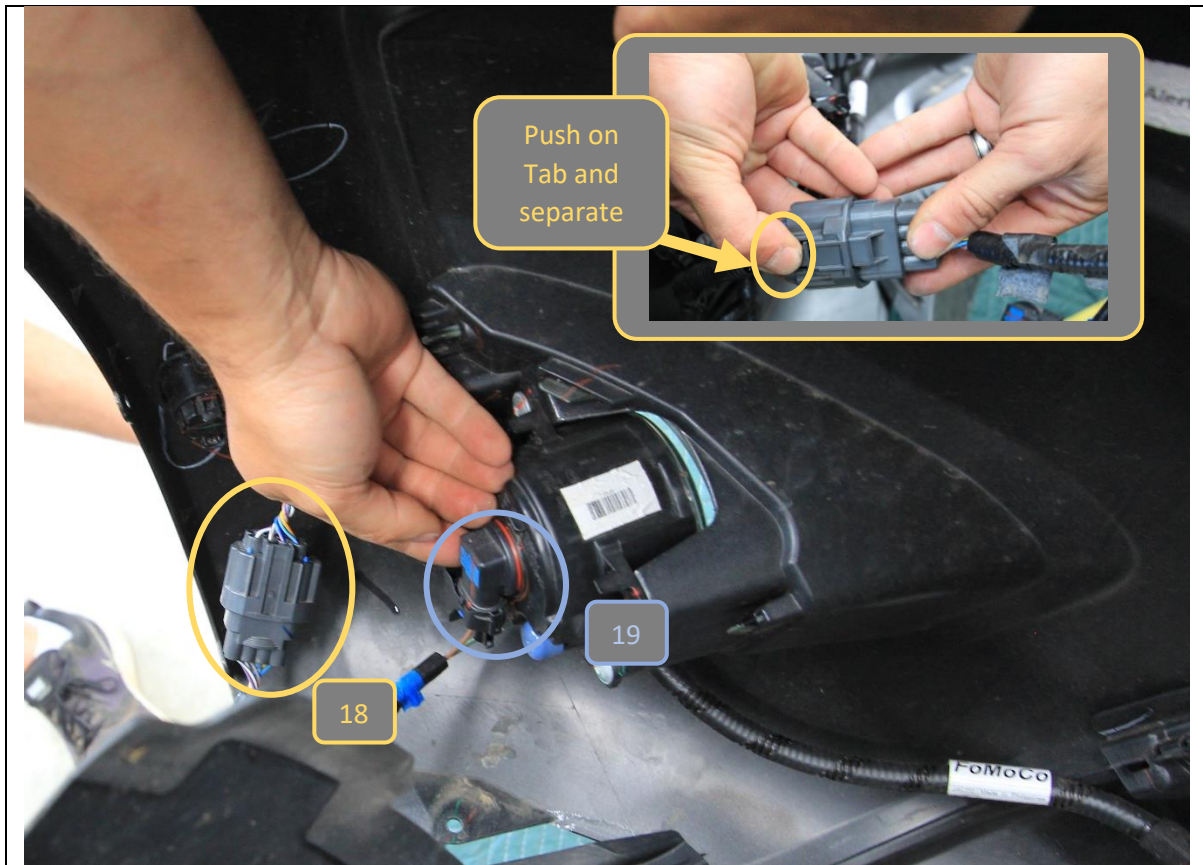

20. Disconnect the main parking sensor loom, on the front passenger side by pushing down on the tab and pulling the connector apart.
21. Disconnect fog lights by rotating lamp holder 90 degrees and removing lamp from fog light assembly. Repeat fog lamp disconnection on both sides of vehicle.

TOOLS REQUIRED

FASTENERS



- 22. Once all clips are free and all wiring disconnected, lift the bumper off the car from the center section.
- 23. Place the bumper on a panel stand or blanket to ensure the grille is not marked.

TOOLS REQUIRED
Panel Stand
or
Soft Blanket

FASTENERS

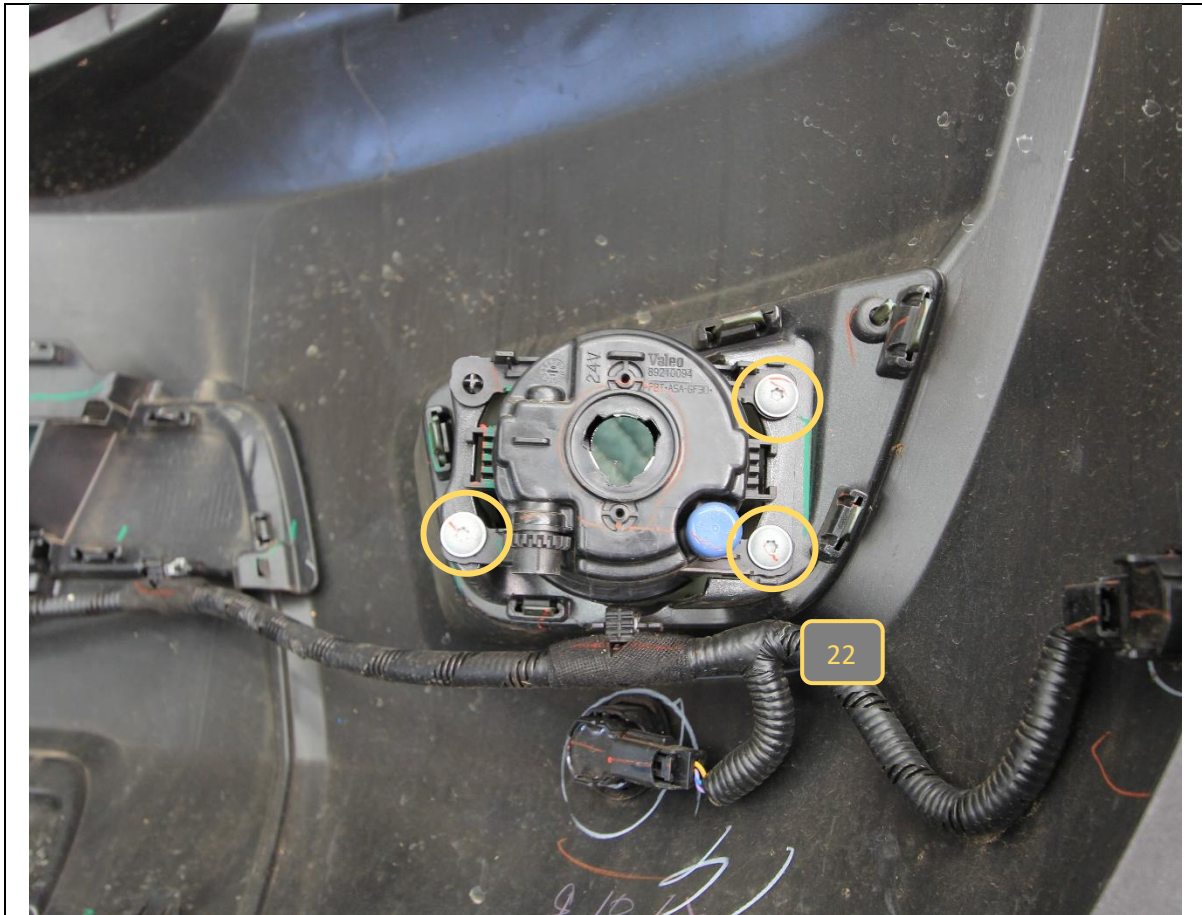

- 24. Remove fog lamp from bumper by removing the 3X T25 Torx screws.
- 25. Repeat for other fog lamp on opposite side of bumper. Retain fog lamps for re-fitment to front bar.

Note: Wildtrack fog lights are not compatible with bar, skip this step for Wildtrack.

TOOLS REQUIRED
T25 Torx Driver

FASTENERS
6x T25 Screw - Discard

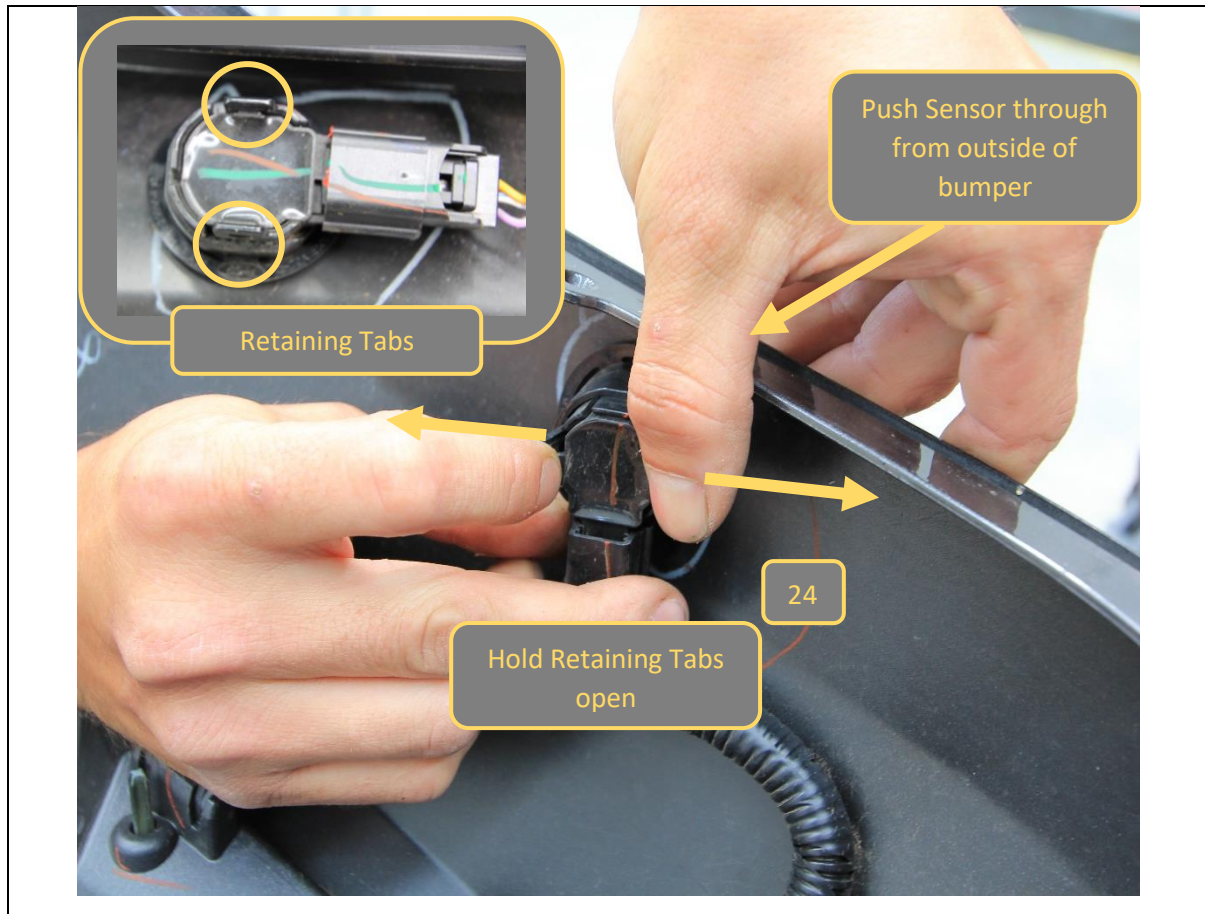

26. Remove parking sensors from housings, by holding open the retaining tabs, whilst pushing the sensor through the housing from the outside of the bumper

27. Repeat for all sensors in the bumper.

TOOLS REQUIRED

FASTENERS

<p>28. Remove parking sensor housings from bumper by squeezing the retaining tabs whilst pushing the inner housing through the bumper from the inside.</p> <p>29. Repeat for all sensors in the bumper. Take care to ensure that each inner and outer housing are matched. Label positions of housings to aid with re-fitment to bar.</p>	<p>TOOLS REQUIRED</p>
	<p>FASTENERS</p>

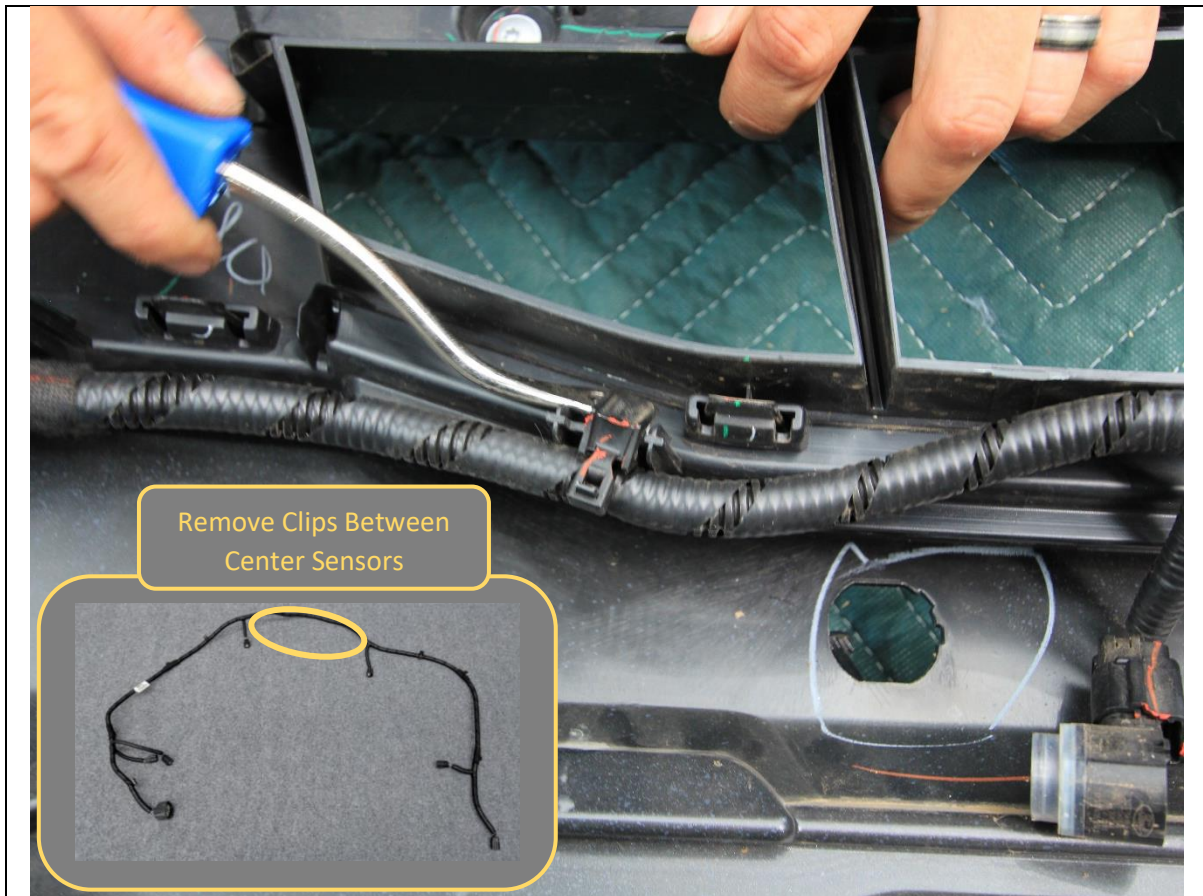

30. Separate parking sensor loom from bumper by prying off all the retaining clips using trim tool.
31. Remove the retaining clips between the two middle sensors by carefully cutting the zip tie part of the retaining clip with side cutters.

TOOLS REQUIRED
Trim Tool
Side Cutters

FASTENERS



- 32. Remove the plastic bumper retainer by removing the 4 securing bolts using a 10mm Socket.
- 33. Repeat for other side of vehicle

TOOLS REQUIRED
10mm Socket

FASTENERS
4x 10mm head bolts -
Discard

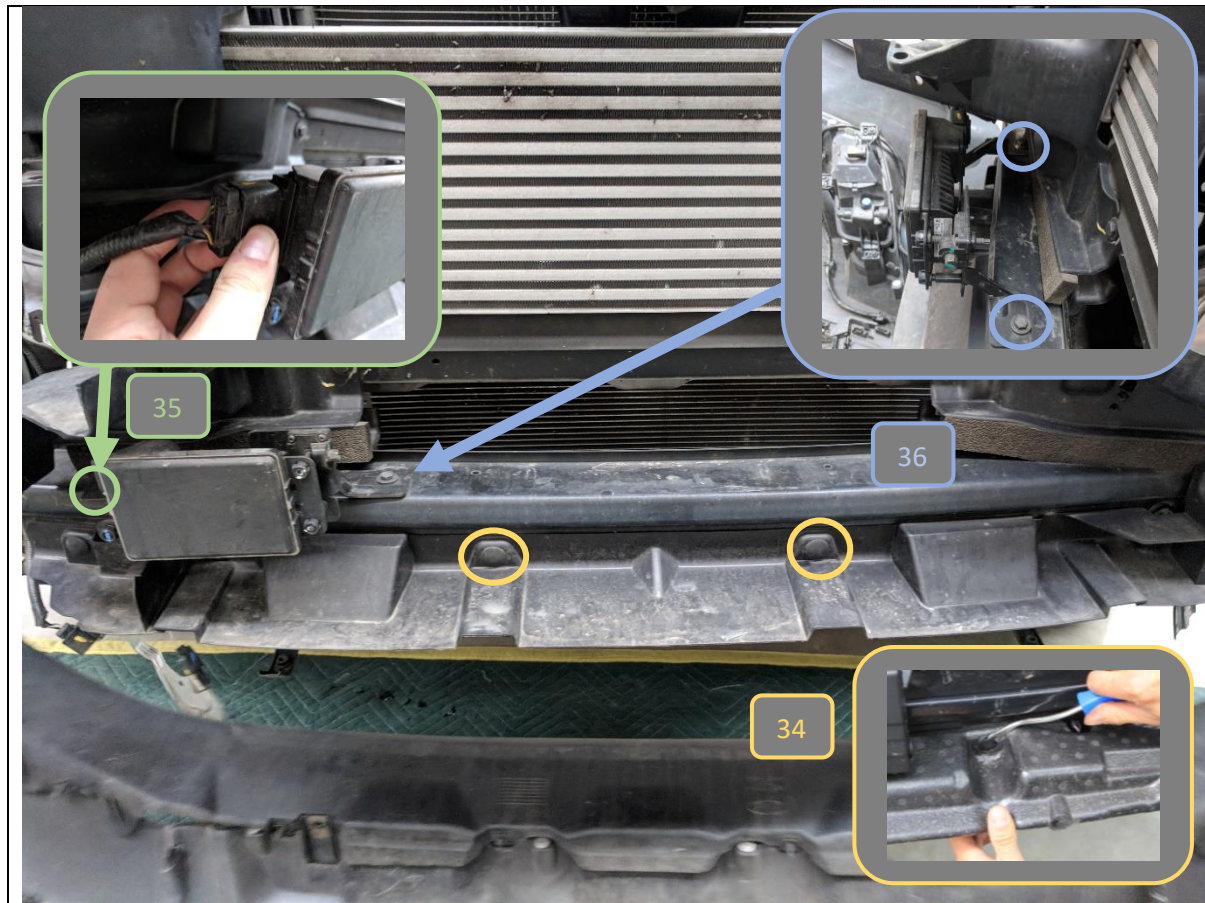

34. Remove the plastic air guide by removing the 2x split head clips. Use a trim tool to pry top part of head to release clip.
35. Unplug and unfasten wiring loom from adaptive cruise control radar sensor (if equipped). Press down on tab on connector to release plug.
- Use trim tool to pry off all harness clips securing loom to the bracket and impact beam.
36. Remove from adaptive cruise control radar sensor (if equipped), using a 10mm socket.

TOOLS REQUIRED

10mm Socket
Trim tool

FASTENERS

3x 10mm head bolts – Discard
2x Split head clips - Discard



- 37. Separate the adaptive cruise control bracket from the support bracket by pulling the bracket out of the ball and socket clips.
- 38. Take care not to drop or damage the adaptive cruise control module. Start with the side with the single clip and release clips one by one. A moderate to firm amount of force is require to release the clips.

TOOLS REQUIRED

FASTENERS



- 39. Remove the lower bumper retaining brackets, by removing the 2x 10mm head bolts. Discard bracket.
- 40. Repeat for other side of vehicle

TOOLS REQUIRED
10mm Socket

FASTENERS
4x 10mm head bolts –
Retain 1x Discard 3x



41. Remove the FM radio antenna from the lower section of the wheel arch liner on the driver's side, using a trim tool to pry it up.
42. Release the cable clip securing the antenna wire from the body panel.
43. Remove the FM radio module from the chassis using 7mm socket / spanner.

TOOLS REQUIRED
10mm Socket

FASTENERS
4x 10mm head bolts - Discard



- 44. Using Electric drill and 6mm drill Bit, Open mounting hole of FM radio module to 6mm.
- 45. Re secure the FM radio module to the chassis using the threaded inserts and bolts originally used for the bottom bumper support bracket. Tighten with 10mm socket.

TOOLS REQUIRED
Drill
6mm Drill Bit
10mm Socket

FASTENERS
1x 10mm head bolts – re use from step 38



- 46. Apply Double sided adhesive tape to rear of FM radio antenna.
- 47. Reconnect the radio antenna cable.
- 48. Re secure the FM radio antenna to the backside of the wheel arch liner, up behind the headlight, using the double-sided adhesive tape

TOOLS REQUIRED
Double sided adhesive tape

FASTENERS

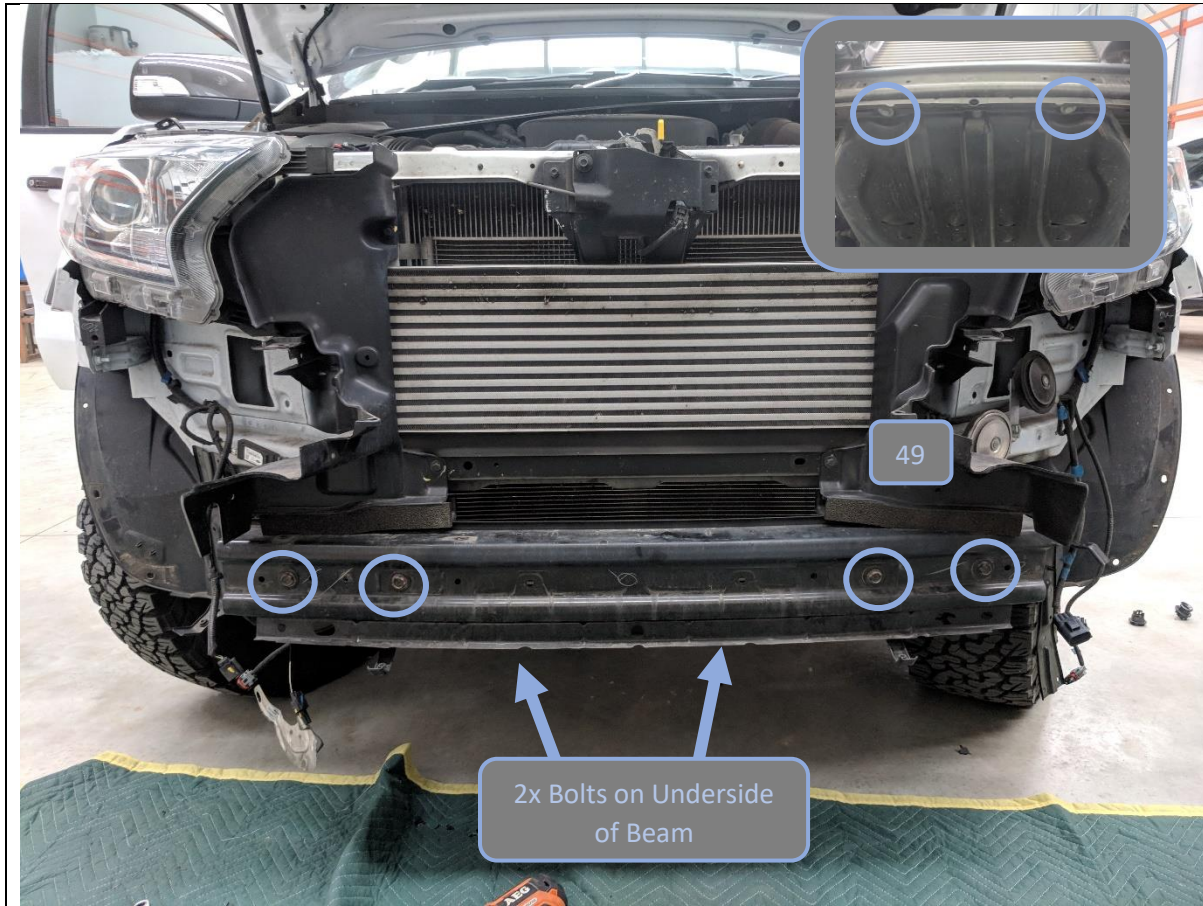

<p>49. Remove the impact beam by removing the 4x M10 bolts securing it to the chassis and 2x bolts securing to bash plate, using a 15mm Socket.</p>	<p>TOOLS REQUIRED 15mm Socket</p>
	<p>FASTENERS 6x M10 Bolts Discard</p>

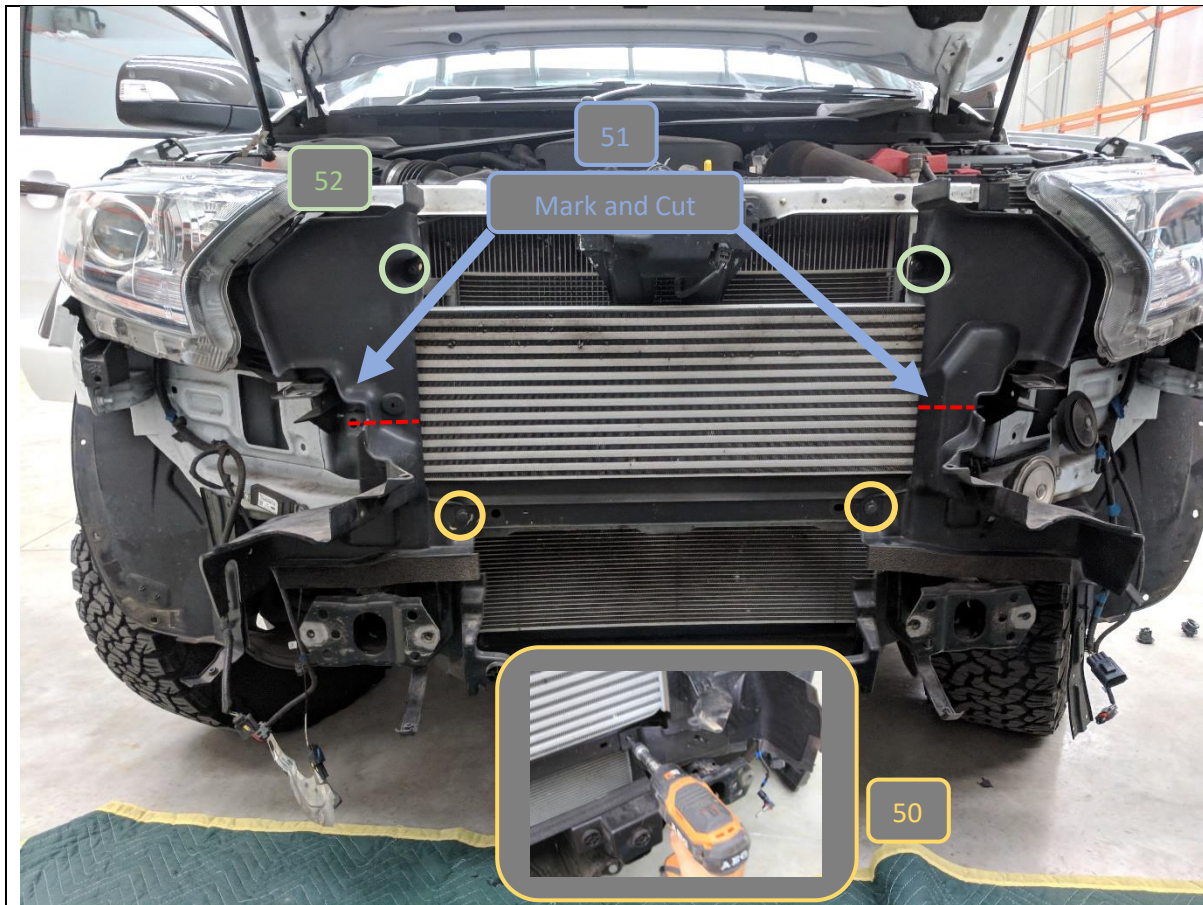

<p>50. Remove 2x M6 bolts securing side air guide to the chassis cross member, using 10mm socket.</p> <p>51. Mark the plastic air guide along the narrowest point, as indicated in figure above. Carefully cut along the mark using utility knife. Take care to ensure wiring looms are clear before cutting.</p>	<p>TOOLS REQUIRED 10mm Socket Utility Knife</p>
<p>52. Remove both parts of the air guide from the vehicle. The top part is secured with 2x 10mm head bolts.</p>	<p>FASTENERS 2x M6 bolts Discard</p>



- 53. Remove the exterior air temp sensor from the bottom part of the air guide using a trim tool to pry up the clips.
- 54. Mark hole spacing required on top portion of air guide, using the sensor as guide.
- 55. Drill new mounting holes in top portion of air guide in positions marked using 6mm Drill bit.

TOOLS REQUIRED
Trim Tool
Drill
6mm Drill Bit

FASTENERS
2x M6 Bolt

Retain for reassembly



56. Re-Fit top portion of air guide using original bolt.

57. Re fit exterior temperature sensor by pushing clips into new holes drilled in top portion of air guide.

TOOLS REQUIRED
10mm Socket

FASTENERS
2x M6 bolts from step 50

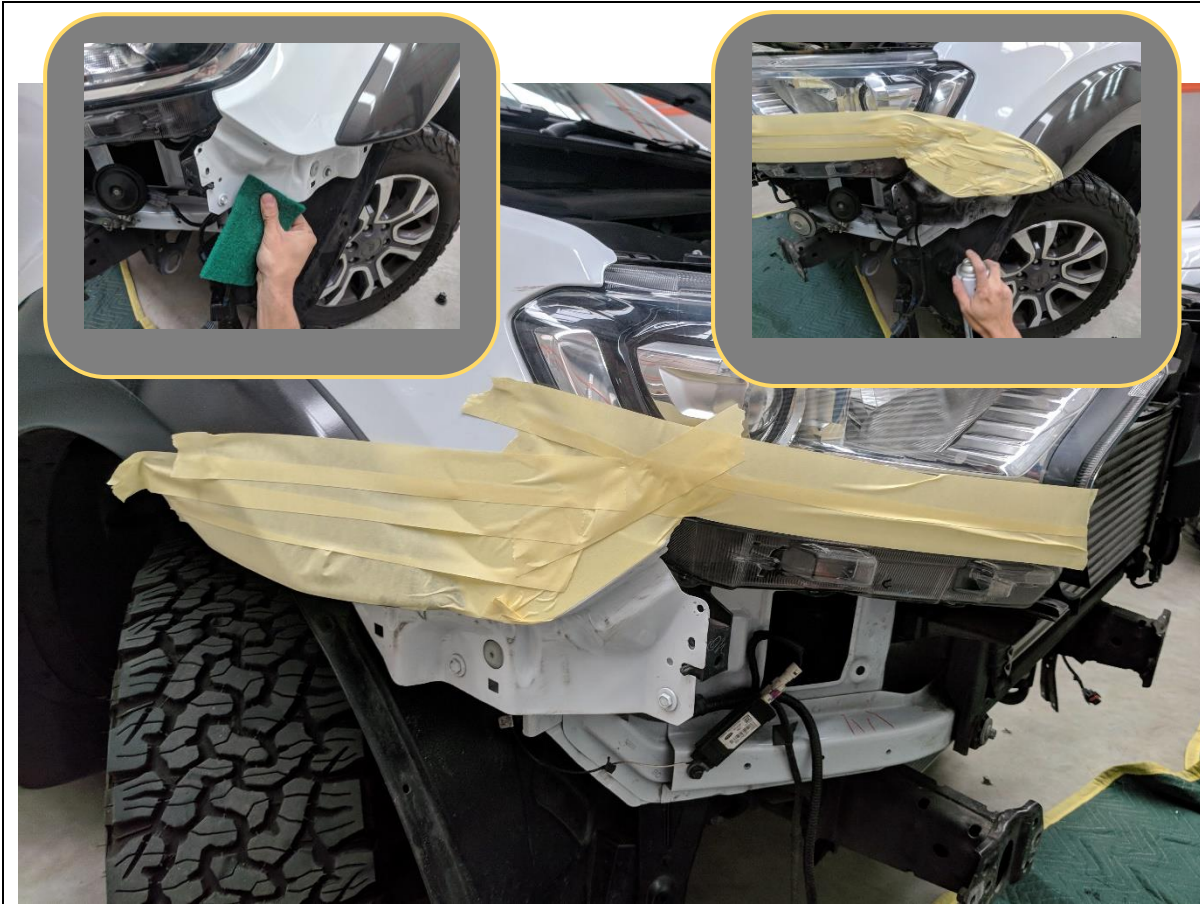

- 58. If vehicle is light colour it is a good idea to paint the areas below the headlight that will be visible behind / under the bar when its fitted.
- 59. Start by cleaning all dirt from areas to be painted and rough up surface with scotch brite or fine sandpaper.
- 60. Carefully mask underneath headlight.
- 61. Spray paint area under headlight with matte black automotive paint. Offroad Animal recommends Motospray "Bumper Black"

TOOLS REQUIRED
 Masking Tape
 Scotch brite / fine grit sandpaper
 Cloth/Rag
 Cleaning solvent
 Matte Black Automotive Paint

FASTENERS



62. Allow paint to dry. It's a good idea to go on with further bar preparation steps whilst paint is drying.

63. Remove masking tape.

TOOLS REQUIRED

FASTENERS

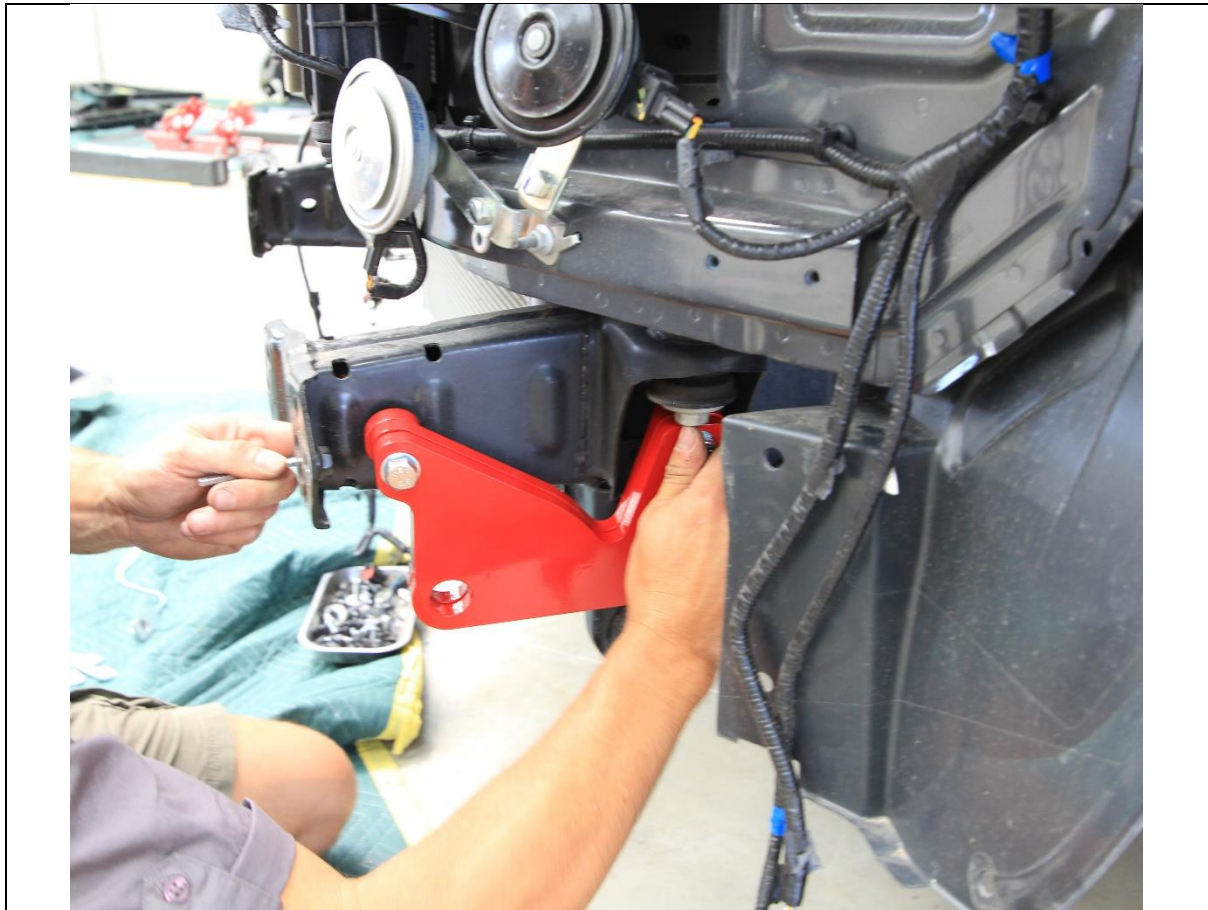

- 64. If fitting Offroad animal tow points, do so at this stage.
- 65. Refer to fitting instructions supplied with tow points.

TOOLS REQUIRED
Refer to Tow point instructions

FASTENERS
Refer to Tow point instructions

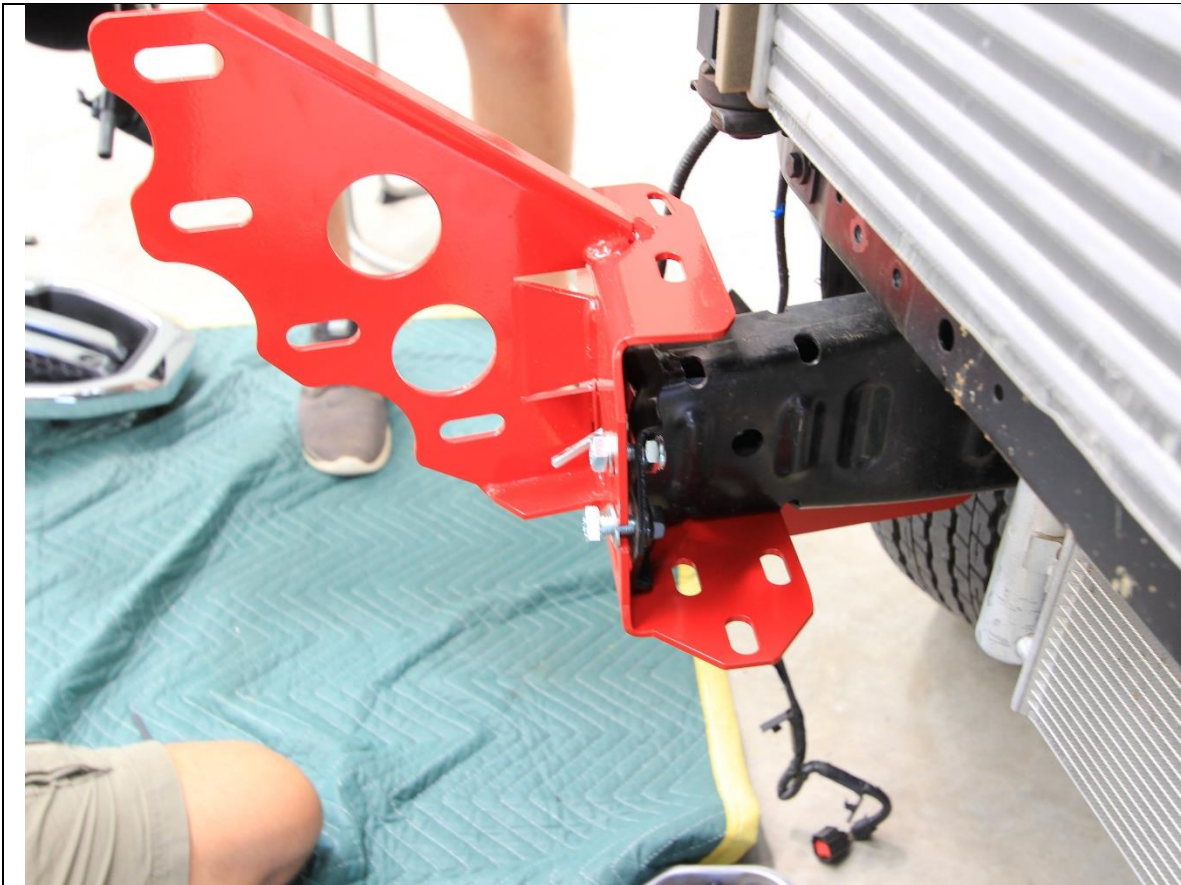

- 66. Fit front impact absorber mount assemblies to the chassis. Secure with M10x30 bolts and flat washers into existing threaded inserts on chassis, and M10x30 Bolts, flat washers and Nyloc Nuts in other locations.
- 67. Secure finger tight only at this stage. Repeat for other side of vehicle.

TOOLS REQUIRED

FASTENERS

- 6x M10x30 Bolt
 - 4x M10 Nyloc Nut
 - 10x M10 Flat Washer
- Per side - From Bolt Kit

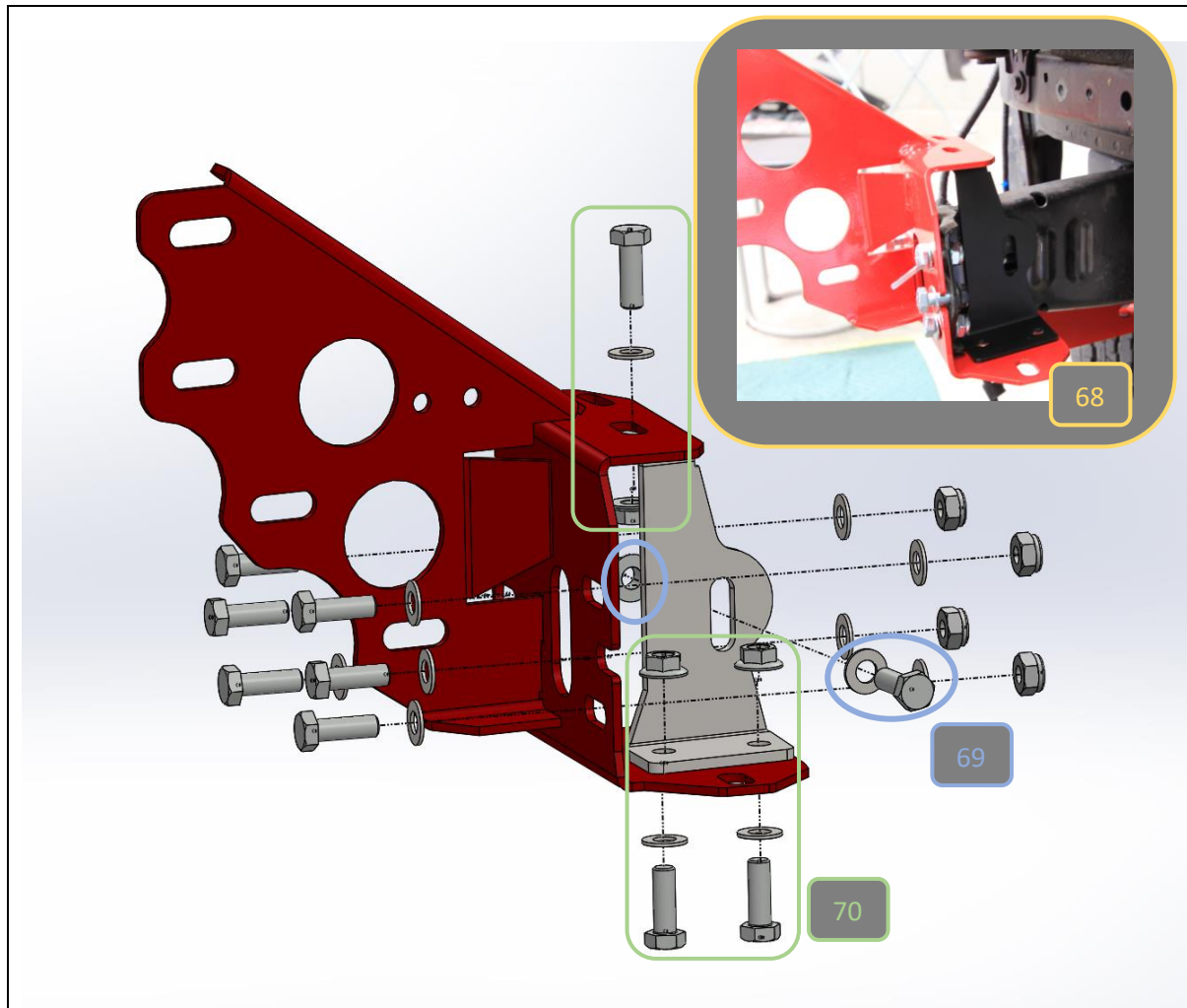

68. Fit Chassis bracket gusset to chassis and mounts.

69. Secure to chassis with M10x30 Bolt, Flat washer and Flange nut, mounted inside the chassis.

70. Secure to mounts using 3x M10x30 Bolts, Flat washers and Flange nuts.

71. Secure finger tight only at this stage. Repeat for other side of vehicle.

TOOLS REQUIRED

FASTENERS

- 4x M10x30 Bolt
- 4x M10 Flange Nut
- 4x M10 Flat Washer

Per side - From Bolt Kit

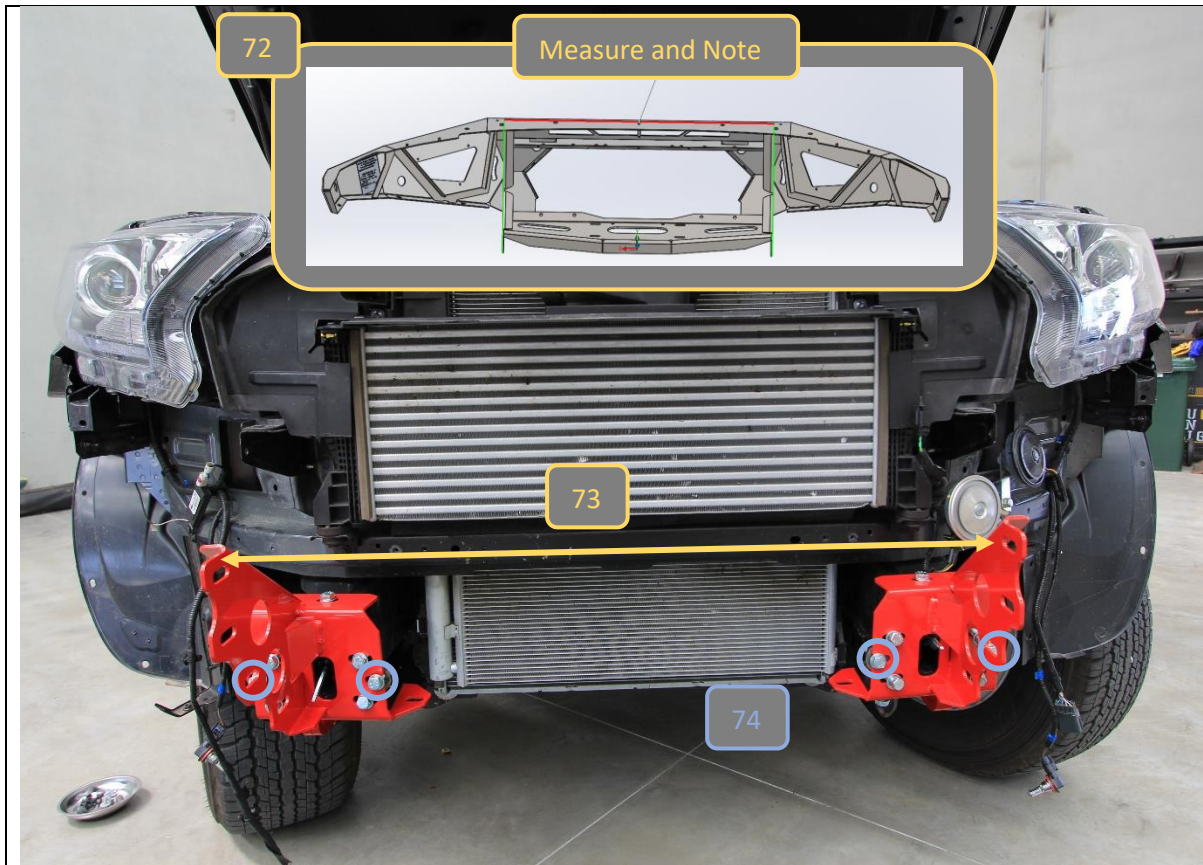

<p>72. Measure and note distance between outside of uprights on bar.</p> <p>Upright Distance _____mm</p>	<p>TOOLS REQUIRED 16mm Socket & Spanner. Soft blow hammer.</p>
<p>73. Measure and adjust distance between mounts to be 1-2mm larger than the distance measured on bar.</p> <p>74. Snug chassis insert bolts using 16mm Socket or spanner. Re check distance. Adjust distance with Soft blow hammer if required.</p> <p>75. Tighten all bolts using 16mm socket and spanner. Re check distance after all fasteners are secure.</p>	<p>FASTENERS</p>

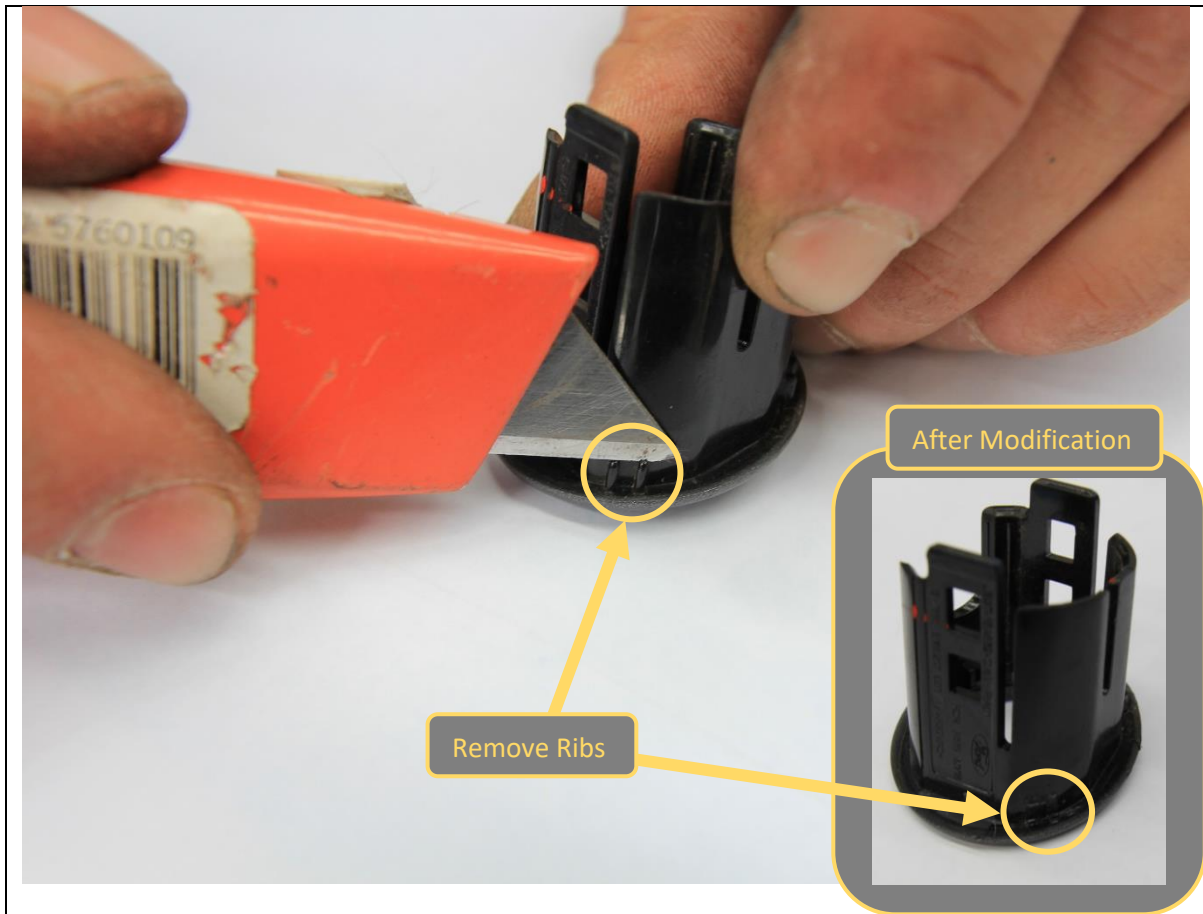

<p>76. Modify sensor housings to fit in font bar by removing the small locating ribs using a utility knife.</p> <p>77. Complete these modifications for all sensor housings.</p>	<p>TOOLS REQUIRED Utility Knife</p>
	<p>FASTENERS</p>



<p>78. Re-fit sensor housings to new front bar in original locations.</p> <p>79. Refitting is opposite of removal, insert the outer part through outside of bar, then replace inner and press together until an audible “click” is heard.</p>	<p>TOOLS REQUIRED</p>
	<p>FASTENERS</p>

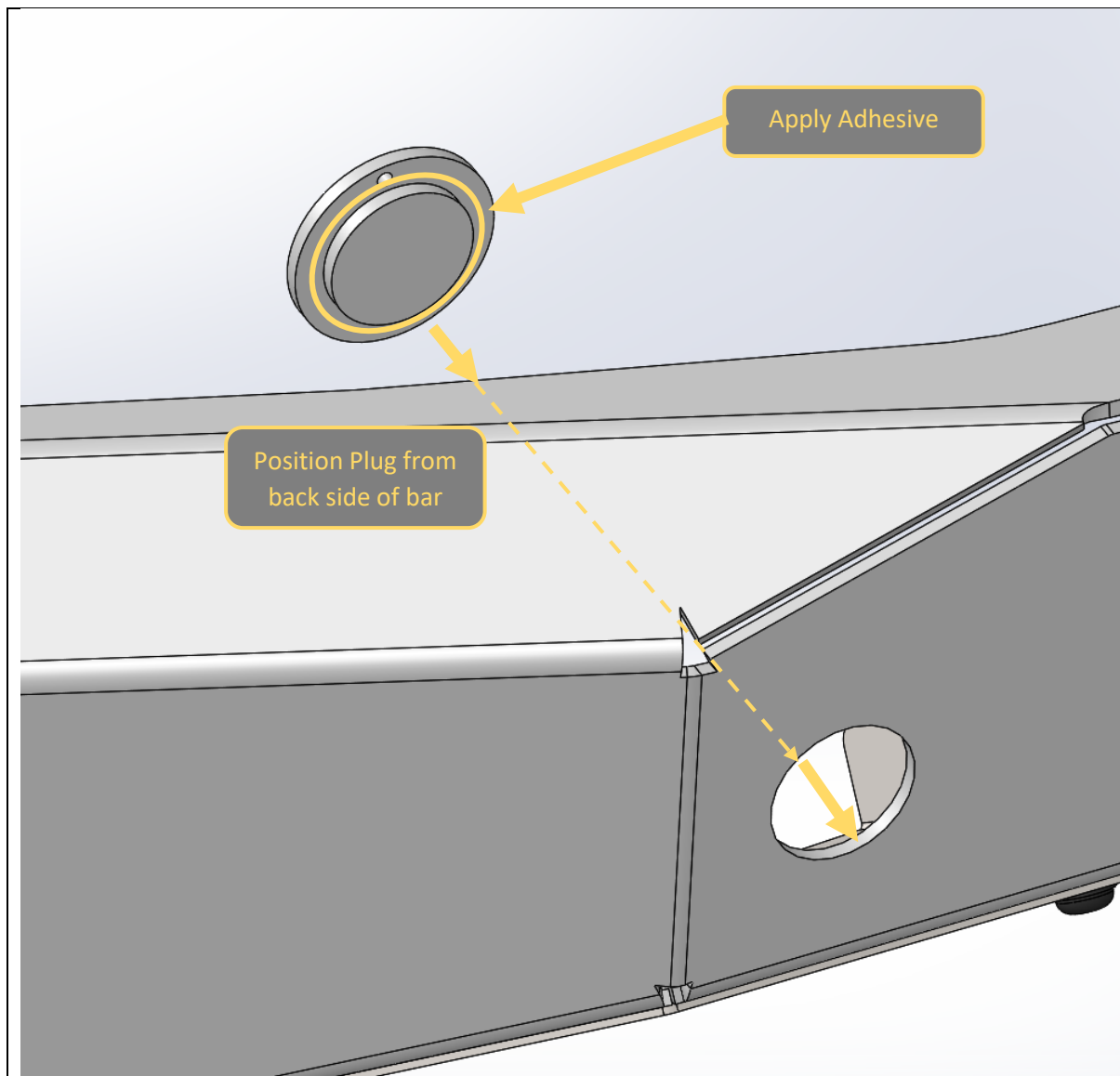

<p>80. If fitting to model with no front parking sensors, fit the sensor plugs to the far outside sensor holes in the bar.</p> <p>81. Apply bead of automotive grade adhesive (such as Sikaflex 227) to the outside ring of the sensor plug.</p> <p>82. Insert the sensor plug into the hole from behind. Ensure the plug sits flush with front of bar.</p> <p>83. Wipe off all adhesive bleed through on front of bar with rag. Secure in place with tape until adhesive cures.</p>	<p>TOOLS REQUIRED Automotive sealant</p>
	<p>FASTENERS</p>



- 84. Route sensor loom through access hole in bar uprights, and behind wing braces ensuring loom is centered in bar.
- 85. Re-fit sensors by pushing into housings until audible "click" is heard.

TOOLS REQUIRED

FASTENERS



86. Insert cage nuts to square slots in bottom of wings. Seat cage nut against one edge of slot then push other edge in with flat bladed screwdriver.

TOOLS REQUIRED
Flat bladed screwdriver

FASTENERS
6x M6 Cage Nuts



- 87. With assistance from either a lifting trolley or another person, Lift the bar up to the vehicle mounts.
- 88. Secure with single M12x30 bolt, Flat washers and Nyloc nut each side at this stage. Leave finger tight.

TOOLS REQUIRED

FASTENERS

- 2x M12x30 Bolt
- 4x Flat Washer
- 2x M12 Nyloc Nut



- 89. Fit the rest of the M12x30 bolts, Flat washers and Nyloc nuts to the bar to mount interface.
 - 90. Set the clearance between the bar and body and tighten all mounting bolts.
- This is best achieved by having another person hold the bar in the correct position whilst mounting bolts are tightened.

TOOLS REQUIRED
18mm Socket & Spanner

FASTENERS

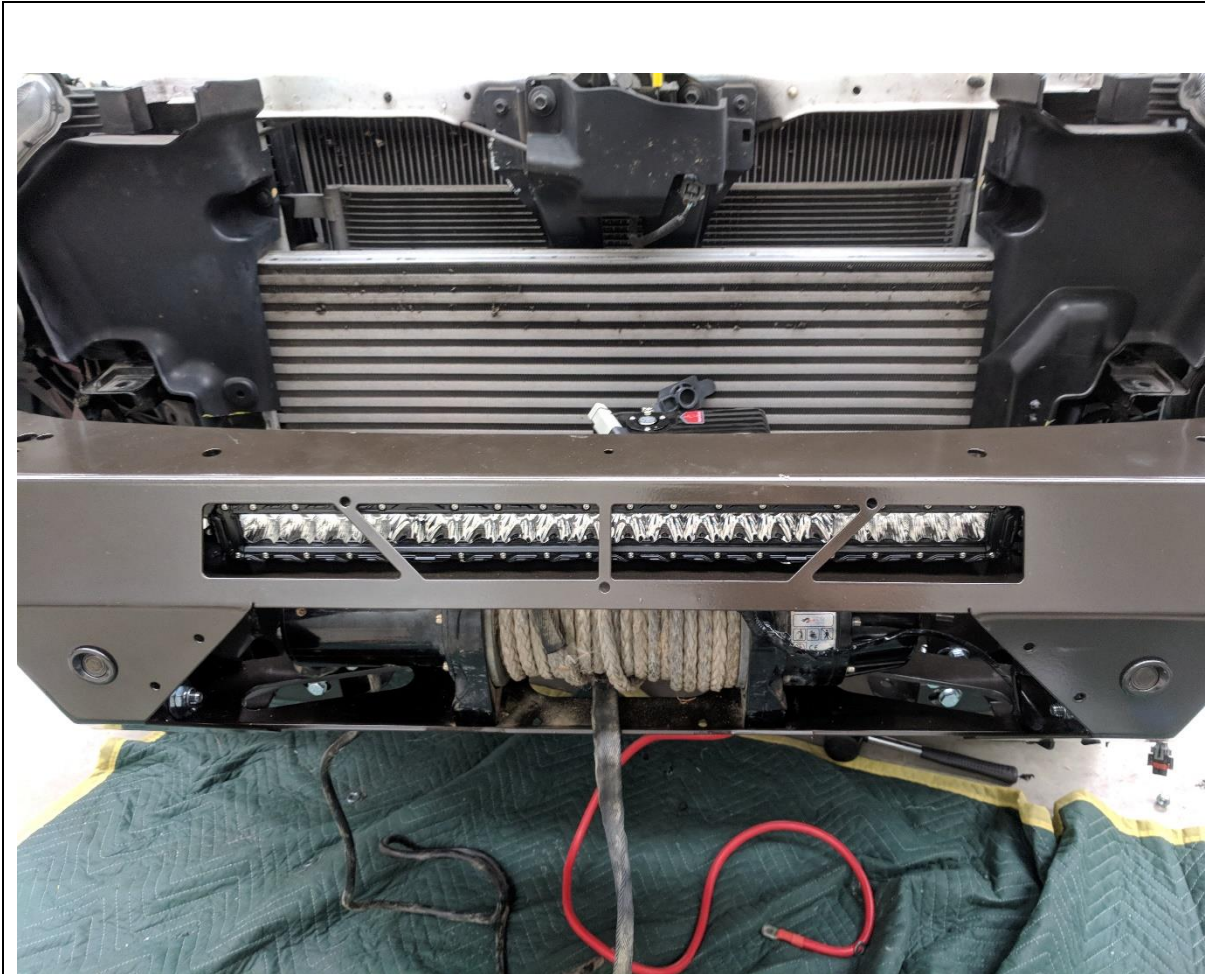

91. If fitting a winch to the bar, do so at this stage. Follow the winch manufacturer's instructions.
92. The winch mounts feet down and is inserted through the front opening of the bar.

TOOLS REQUIRED
Refer to winch instructions

FASTENERS
Refer to winch instructions

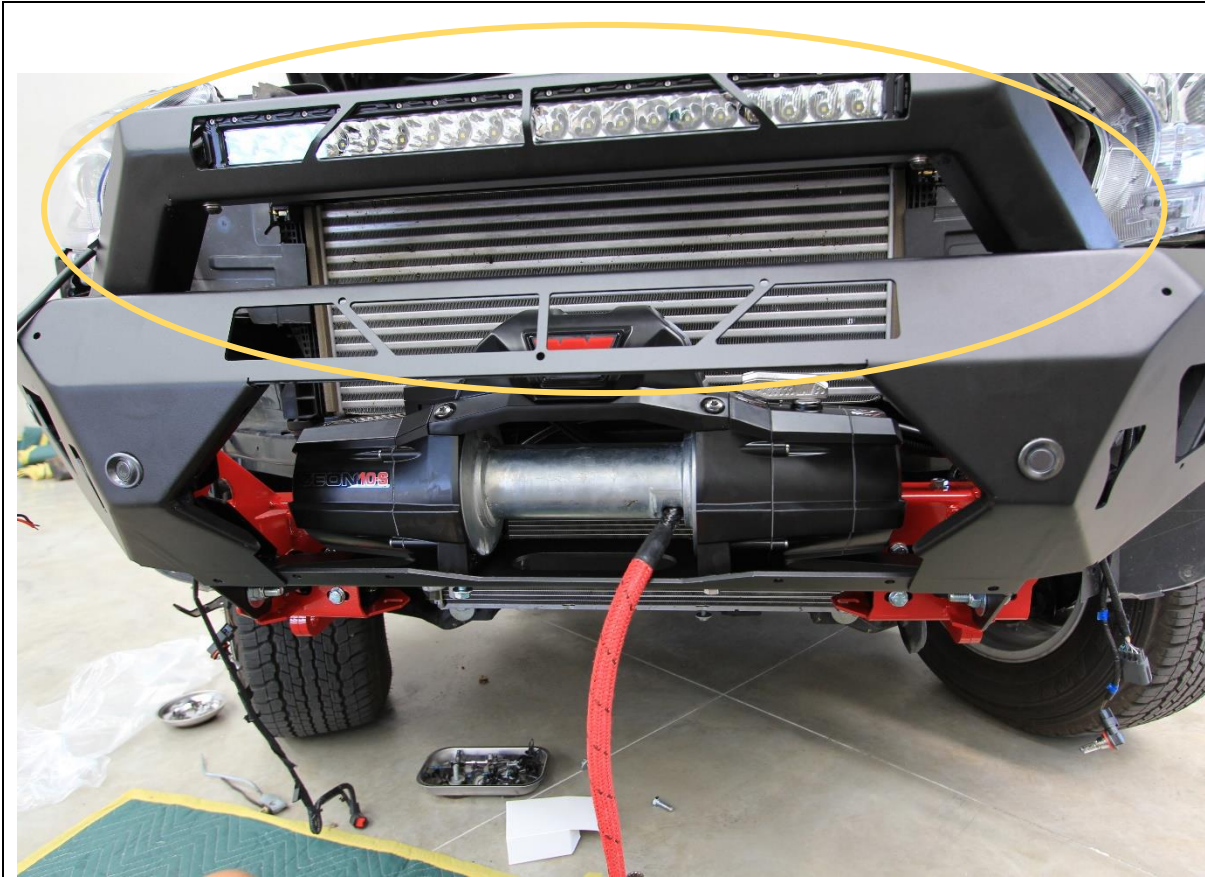

- 93. If fitting a top hoop to the bar, do so at this stage. Follow instructions supplied with the top hoop kit.
- 94. It is also good time to complete any wiring required for fitment of Lights / UHF on the bar.

TOOLS REQUIRED
Refer to hoop instructions

FASTENERS
Refer to hoop instructions



- 95. Fit headlight infill panels to the top of the wing, using M6x16 button head bolts, M6 flat washers and Flange nuts. Secure finger tight only at first.
- 96. Align panels to have even gap with headlight and secure in place. Repeat for both sides of vehicle.

TOOLS REQUIRED
4mm Hex key

FASTENERS
4x M6 x16 button head
4x M6 flat washer
4x M6 flange nut



- 97. Grille needs to be trimmed on PX2 to fit with new Offroad animal bar.
- 98. Mark the cuts in the positions as shown above.
- 99. Cut the grille using an angle grinder or air hacksaw along the lines marked.
- 100. If fitting integrated control box winch, make same cuts as mentioned earlier in step

TOOLS REQUIRED
Angle Grinder or Air Hacksaw
Paint Marker

FASTENERS



- 101. If vehicle is equipped with Adaptive cruise control, prepare the sensor for re-fitment to bar.
- 102. Carefully remove the plastic retaining clips from the back of the sensor module bracket by squeezing with pliers, whilst pushing clip through the bracket.
- 103. Fit the sensor module to the cutout in the LHS Mesh panel using 3x M8x16 Button head bolts, flat washers and Flange nuts.

TOOLS REQUIRED

- Pliers
- 4mm Hex Key
- 10mm Spanner

FASTENERS

- 3x M8x16mm Button head bolts
- 3x M8 Flat Washer
- 3x M8 Flange Nuts

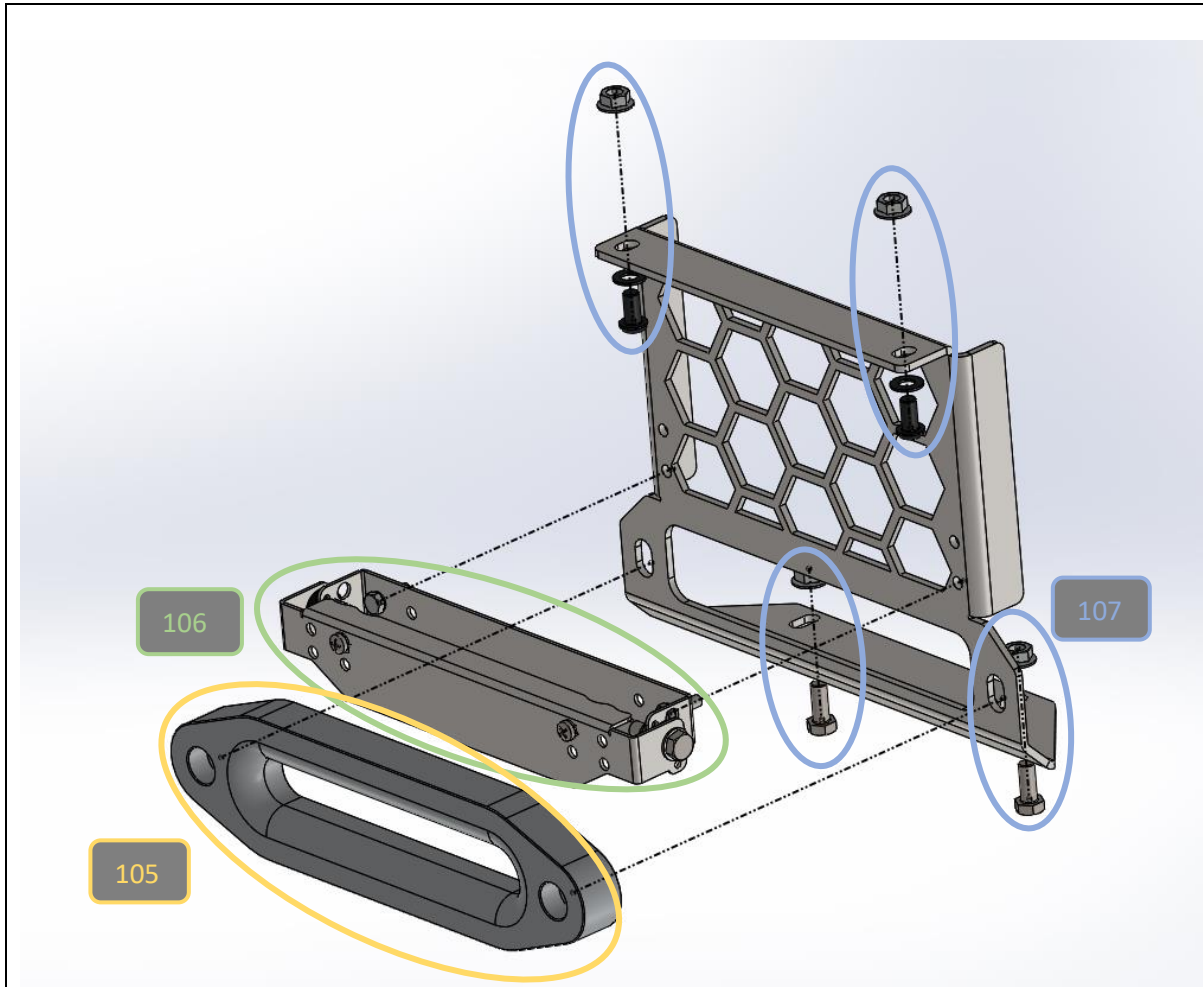

104. Prepare the center mesh panel for installation.

105. If fitting winch, fit the winch fairlead to the center panel, using fasteners supplied by the winch manufacturer.

106. Fit the number plate flip bracket, using 2x M6x20 Hex head bolts, Flat washers and flange nuts

107. Fit the center mesh panel to the bar, using M8x20 Button head (top) and Hex (bottom) bolts, M8 flat washers and M8 Flange nuts.

TOOLS REQUIRED

4mm Hex Key,
10mm Spanner
13mm spanner & socket.

FASTENERS

2xM6x20 Hex Head Bolts
6x M6 Flat Washer
6x M6 Flange Nuts
2x M8x20 Hex Bolt
2xM8x20 Button Head
4x M8 Flat Washer
4x M8 Nyloc Nut



108. Reconnect wiring harness for adaptive cruise control sensor module

109. Fit the outside mesh panels, at the top only using M8x16 Button head bolts M8 Flat washers and M8 Flange nuts.

TOOLS REQUIRED

Pliers
5mm Hex Key
13mm Spanner

FASTENERS

4x M8x16mm Button head bolts
4x M8 Flat Washer
4x M8 Flange Nuts

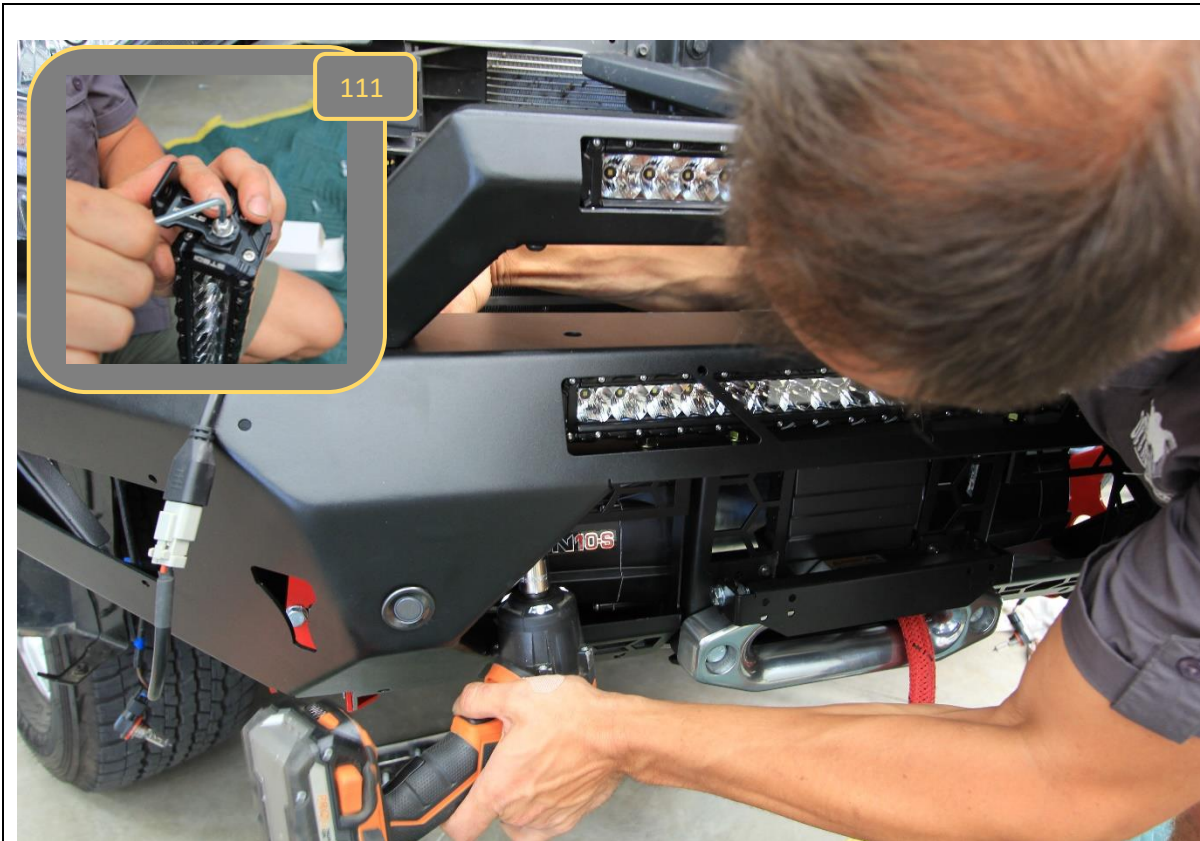

110. If fitting a light bar to the center section of the bar, do so at this stage.

111. Assemble the STEDI Light bar with mounting feet in the outside position. Fit to bar from above through vehicle grille opening. Secure with hardware supplied with the light bar.

Note if not fitting a STEDI light bar, universal light bar mounting kit may be required.

112. If not fitting a light bar, fit cover plate to front of bar. Refer to cover plate kit instructions.

TOOLS REQUIRED

- Pliers
- 5mm Hex Key
- 13mm Spanner

FASTENERS

(if fitting cover plate)

- 5x M6x16mm Button head bolts
- 5x M6 Flat Washer
- 5x M6 Flange Nuts



- 113. If re-fitting factory fog lamps, fit the fog lamps to the supplied fog lamp brackets using the M5x15 screws and Flange nuts provided.
- 114. Fit the fog lamp brackets, to the light mesh panels using 3x M8x16 Button head bolts,
- 115. If fitting own lamps in light mesh, fit now using slots on panel, and hardware provided with lights.
- 116. Repeat for both sides of vehicle.

TOOLS REQUIRED
Phillips Head Screwdriver
13mm Spanner / Socket
5mm Hex Key

FASTENERS
(if fitting fog lamp)
4x M5x15mm screw
4x M5 Flange Nuts

3x M8x16mm Button head bolts
3x M8 Flat Washer
3x M8 Flange Nuts

Per side



117. Fit light mesh panels to the bar. Position the panel from underneath the bar and align with the mounting holes in the wing. Secure with 4x M6x16mm Button head bolts and M6 Flange Nuts

118. Repeat for other side of vehicle.

TOOLS REQUIRED

Pliers
5mm Hex Key
10mm Spanner

FASTENERS

4x M6x16mm Button head bolt
4x M6 Flange Nut



- 119. Reconnect fog light bulbs to housing, by inserting lamp at 90degree angle and rotating to lock in place. Repeat for both sides of vehicle.
- 120. Reconnect Parking sensor loom. Push connector together until click is heard.

TOOLS REQUIRED

FASTENERS



121. Re-Fit grille to vehicle.

122. Secure grille at top using original bolts, removed earlier.

TOOLS REQUIRED
10mm Spanner & Socket

FASTENERS
2x M6x20 Bolt
2xM6 Flat washer
2x M6 Flange nut



<p>123. Fit bash plate to bar first using M8X20 Button head bolts, flat washers, shim plate and M8 Flange nut.</p>	<p>TOOLS REQUIRED</p> <ul style="list-style-type: none"> 5mm Hex Key 6mm Hex Key 15mm Spanner & Socket 16mm Spanner & Socket
<p>124. Secure bottom of bash plate to mount using M10x30 button head bolts, Flat washer and M10 Flange nut.</p>	
<p>125. Re-fit Factory underbody bash plate using original bolts. Secure to Offroad animal bash plate using supplied M10 flange nut, positioned through access hole.</p>	<p>FASTENERS</p> <ul style="list-style-type: none"> 4x M8x20 Button head bolt 4x M8 Flat Washer 2x Shim Plate 2xM10x20 Button head 2xM10 Flat Washer 4x M10 Flange nut 4x OE Flange Head Bolts (for bash plate)

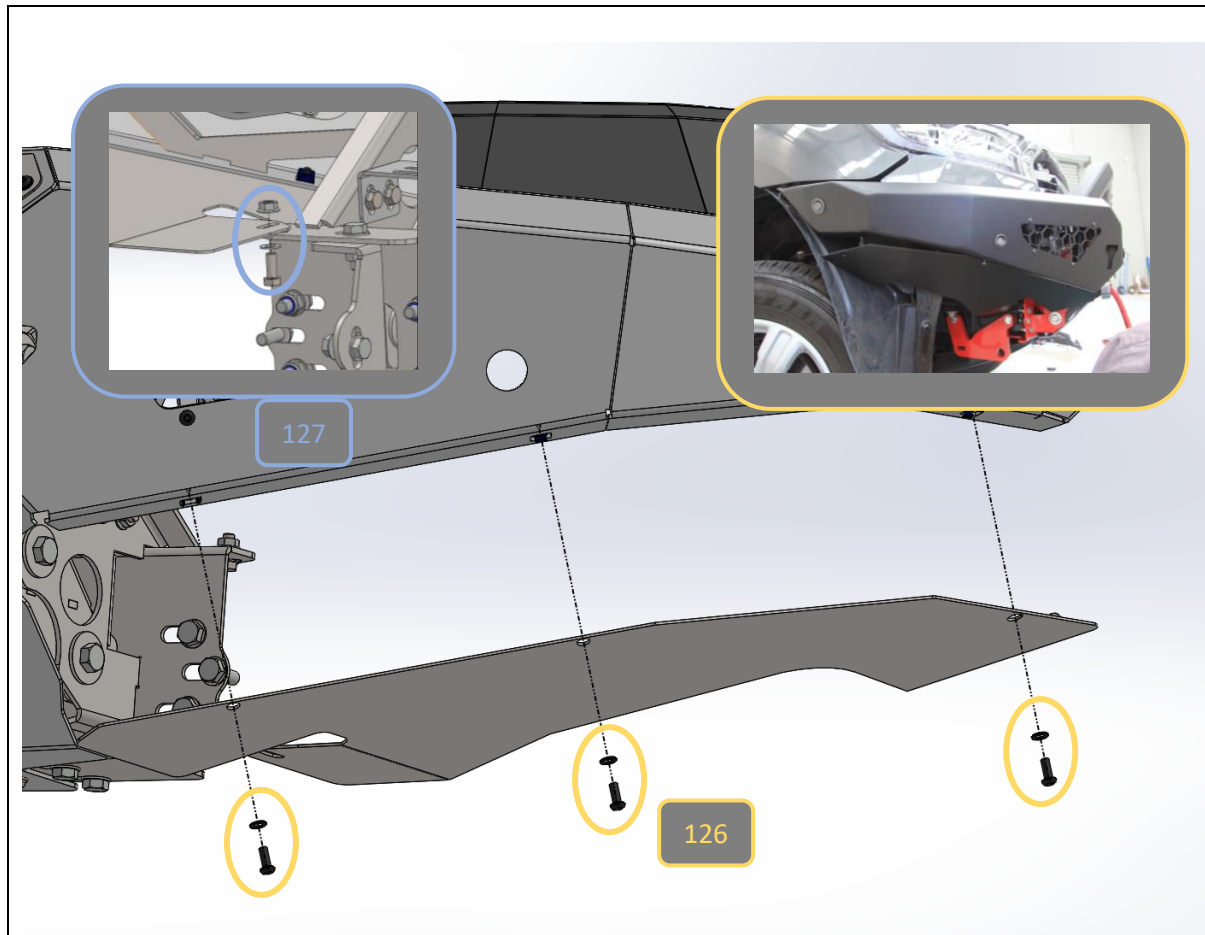

126. Fit side under panels to bar and secure with 3x M6x16 Button head bolts and M6 Flat washers, into M6 cage nuts fitted earlier.

Fitting center bolt first will make it easier to align panel to bar.

127. Secure the back corner of underpanel to mount using M8x20 Hex bolt, Flat washer and M8 Flange Nut.

128. Repeat for other side of vehicle.

TOOLS REQUIRED

4mm Hex Key

FASTENERS

- 6x M8x20 Button head bolt
- 6x M6 Flat Washer
- 2xM8x20 Hex head
- 2xM8Flat Washer
- 2x M8 Flange nut

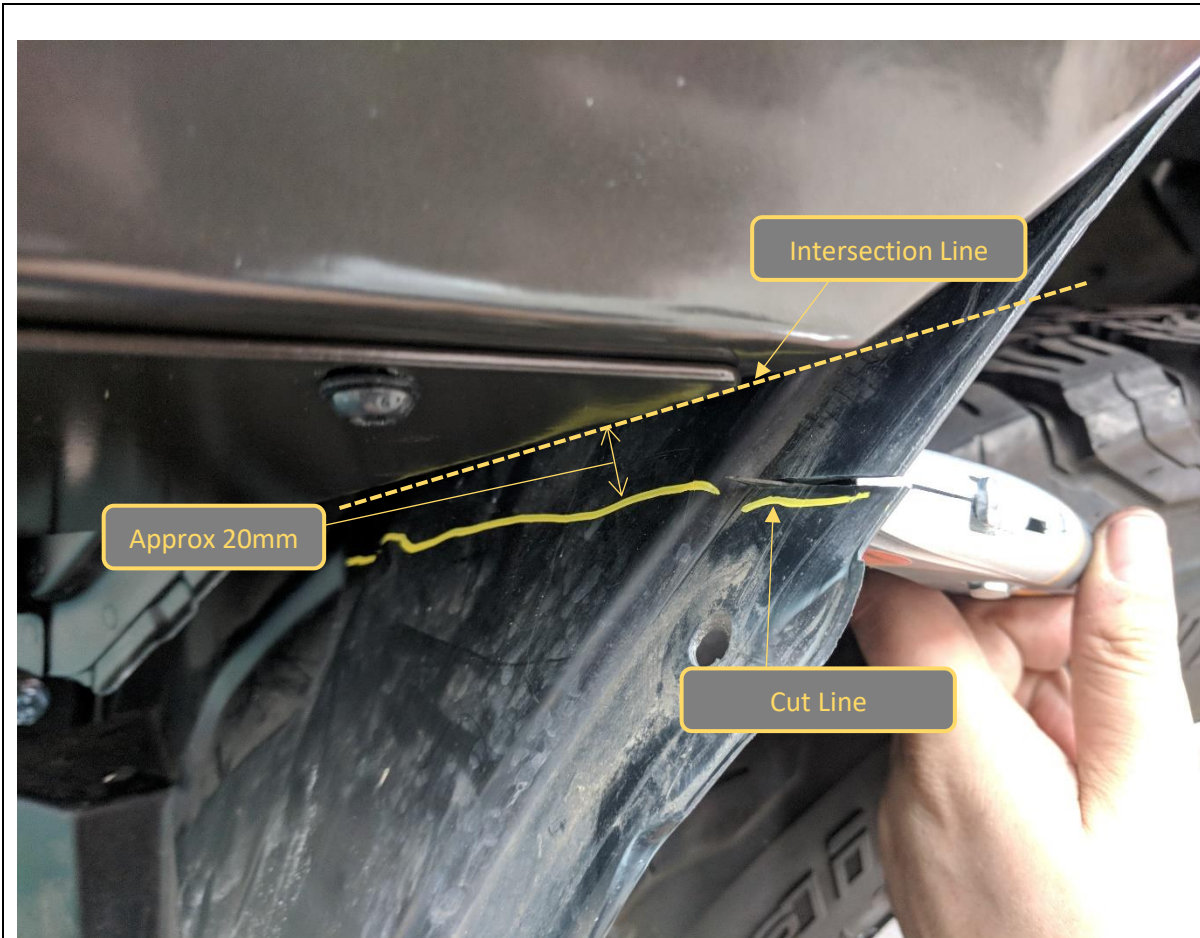

- 129. Mark where wheel arch liner intersects with side under panel with paint pen or other marker.
- 130. Create line offset approximately 20mm below intersection point.
- 131. Trim wheel arch liner to this line using utility Knife.
- 132. Insert wheel arch liner behind flange on side under panel.
- 133. Repeat for both sides of vehicle.

TOOLS REQUIRED

- Marker
- Utility Knife

FASTENERS



134. Re-Fit the number plate to the number plate flip, using the M5x15

135. Fit the Offroad animal logo to front face of bar, using the pre-applied double side adhesive.

TOOLS REQUIRED
Phillips head screwdriver

FASTENERS
M5x15 Phillips Head
M5 Flange Nut



136. Replace plastic radiator trim. Replace 5x plastic push rivets inserting in hole, then pushing down center part.

137. Close the bonnet and you are done!

TOOLS REQUIRED

FASTENERS

5x Plastic Push Rivet



Congratulations!
Head for the tracks and enjoy your newly protected Ford Ranger!