



RAM 1500 DS 2017– On PREDATOR & TORO FRONT BAR

IMPORTANT! – READ BEFORE INSTALLATION

- When installed in accordance with these instructions, the front protection bar does not affect the operation of the vehicles SRS airbags.
- This product must be installed exactly as per these instructions using only hardware supplied.
- Take a few moments to read instructions thoroughly before beginning work.
- In the event of damage to any bar component please contact OFFROAD ANIMAL to arrange repair/replacement of components.
- Do not use this product for any vehicle make or model other than that specified on these instructions.
- Do not remove labels from this product.
- This product and its fixings must not be modified in any way unless stated in these fitting instructions.
- The installation of this product is recommended for trained personnel.
- These instructions are correct at time of publication. OFFROAD ANIMAL cannot be held responsible for the impact of any changes subsequently made by the vehicle manufacturer. If you find something has changed please contact us to let us know!
- During installation it is the duty of the installer to check correct operation/clearances of all components.
- If Instructions are to be printed for reference in the workshop, it is recommended that they are printed in colour, for best legibility.

PARTS LISTING

IMPORTANT: Check all parts are present before beginning work! Contact OFFROAD ANIMAL if something is missing.

Main Parts – In the Box

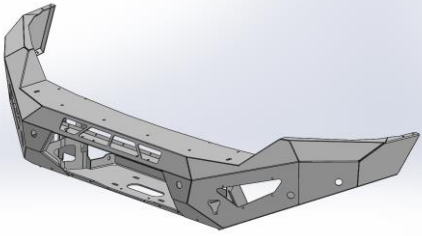
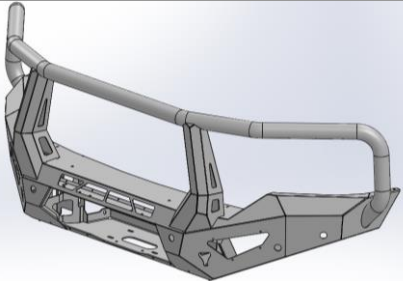
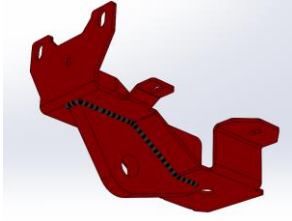
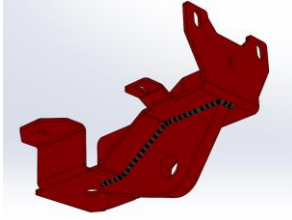
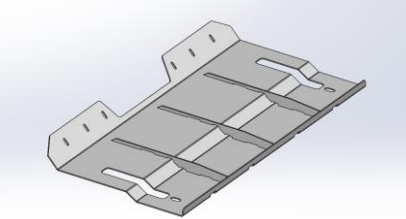
Qty	Part Number	Description	Image
1	FB-R15-DS-17-PR-ASM1	RAM 1500 DS PREDATOR WELDED BAR ASSY	
OR			
1	FB-R15-DS-17-TOR-ASM1	RAM 1500 DS TORRO WELDED BAR ASSY	
1	FB-R15-DS-17-ASM2L	RAM1500 Tow Point Assy	
1	FB-R15-DS-17-ASM2R	RAM1500 Tow Point Assy	
1	FB-R15-DS-17-ASM3	RAM1500 Bash Plate Assy	

<p>1</p>	<p>M-0016</p>	<p>RAM 1500 Predator Fairlead Mesh</p>	
<p>1</p>	<p>M-0017L</p>	<p>RAM 1500 Predator Side Mesh</p>	
<p>1</p>	<p>M-0017R</p>	<p>RAM 1500 Predator Side Mesh</p>	
<p>1</p>	<p>M-0002L</p>	<p>Light Cover Mesh</p>	
<p>1</p>	<p>M-0002R</p>	<p>Light Cover Mesh</p>	
<p>1</p>	<p>U-0025L</p>	<p>RAM 1500 Predator Wing Under panel</p>	
<p>1</p>	<p>U-0025R</p>	<p>RAM 1500 Predator Wing Under panel</p>	

<p>2</p>	<p>B-0387</p>	<p>RAM 1500 Predator Winch Brace</p>	
<p>1</p>	<p>B-0186L</p>	<p>Fog Lamp Bracket</p>	
<p>1</p>	<p>B-0186R</p>	<p>Fog Lamp Bracket</p>	
<p>1</p>	<p>B-0388L</p>	<p>Ram1500 Headlight Infill</p>	
<p>1</p>	<p>B-0388R</p>	<p>Ram1500 Headlight Infill</p>	
<p>1</p>	<p>B-0454L</p>	<p>RAM 1500 Parker Bracket</p>	
<p>1</p>	<p>B-0454R</p>	<p>RAM 1500 Parker Bracket</p>	

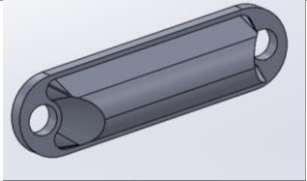
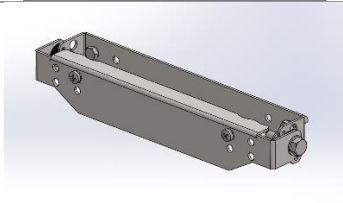
<p>1</p>	<p>LED AUTOLAMPS 16W12-2</p>	<p>LED AUTOLAMPS 16 Series Marker Lamp, White, 12V, Twin Blister Pack</p>	
<p>1</p>	<p>NPF-COM-SM- ASM0</p>	<p>Number plate flip asm Small</p>	

Small Parts – Contained in Small Parts Kit Bag

Qty	Part Number	Description
10	M8 X 20 BHCS BLACK ZINC	SCREW, BUTTON HEAD CAP, M8X20X1.25 BLACK ZP
16	M8 FLAT WASHER- BLACK ZINC	M8 FW- BLACK ZINC
30	M8 FLANGE NUT	Flange Nut, M8x1.25 G8.8 ZP
14	M8 X 20 HEX	Bolt Hex, M8X20x1.25, GR8.8 ZP
14	M8 FLAT WASHER	M8 FW
6	M8 X 16 BHCS BZP	SCREW, BUTTON HEAD CAP, M8X16X1.25 GR12.9 BLACK ZP
4	M12X40	Bolt Hex, M12X40X1.75, GR8.8 ZP
6	M12 Nyloc nut	M12 NYLOC NUT
14	M12 FW LHD	M12 FW Large Heavy Duty
2	M12X30	Bolt Hex, M12X30x1.75, GR8.8 ZP
20	M6 FLANGE NUT	Flange Nut, M6x1 G8.8 ZP
22	M6x16 BHCS BLACK ZINC	SCREW, BUTTON HEAD CAP, M6X16X1 GR12.9 BLACK ZP
22	M6 FLAT WASHER BLACK ZINC	M6 FW BLACK ZP
10	M6CN3MM	CAGE NUT M6x2.6-3.5
2	M10 x 25	Bolt Hex, M10X25x[1.5], GR8.8 ZP
4	M10 FLANGE NUT	Flange Nut, M10x1.5 G8.8 ZP
2	M10 Flat Washer	M10 FW
2	M10 X 130	Bolt Hex, M10X130X1.5, GR8.8 ZP
8	M10 FW LHD	WASHER, FLAT M10X28.5X2.5
2	M10 x 30	Bolt Hex, M10X30x[1.5], GR8.8 ZP
2	M10 NYLOC	M10 NYLOC
2	M12X40x1.5	Bolt Hex, M12X40x1.5, GR8.8 ZP
6	FB-FRA-PX-19- PR-ASM3	Sensor Cover Plate
4	M3 FLAT WASHER	Flat Washer M3, 7mmODx0.5mm T
4	M3 NUT	Hex Nut, M3x0.5 G48.8 ZP
4	M3 X 12 CSK	SCREW, COUNTERSUNK PHILLIPS, M3X12X0.5 ZP
Additional Parts Toro ONLY		
1	B-0392L	RAM 1500 Torro Antenna Bracket
1	B-0392R	RAM 1500 Torro Antenna Bracket
4	M8 X 20 BHCS BLACK ZINC	SCREW, BUTTON HEAD CAP, M8X20X1.25 BLACK ZP
4	M8 FLAT WASHER- BLACK ZINC	M8 FW- BLACK ZINC

TOOLS REQUIRED

The following tools will be required to install the product.

Hand Tools	Power Tools	Workshop Supplies
Metric Socket Set 8-19mm Socket Extension Bar Metric Spanner Set 10-19mm Hex (Allen) Key Set 4-6mm Trim Puller Tool Flat Blade Screwdriver set Phillips Head Screwdriver set Utility Knife Side Cutters Pliers Wire Stripper	Electric Drill 6mm Drill Bit Air Hacksaw or Angle Grinder Electric/Air Impact Driver (Optional) Soldering Iron	Panel Stand or Soft Blanket Cable Ties Masking Tape Black Automotive paint Scotch Brite or Fine Sandpaper Automotive Sealant/Adhesive Automotive Wire

WORKSHOP SAFETY

It is the responsibility of the installer to always complete works in a safe manner. Make sure the following safety equipment is available and precautions are observed whilst fitting this product.

<p>Hearing Protection</p> 	<p>Always wear ear protection when using power tools.</p>
<p>Eye Protection</p> 	<p>Ensure eye protection is always worn when cutting or drilling.</p>
<p>Manual Handling</p> 	<p>Do not attempt to lift bar assemblies or rock sliders on your own.</p> <p>Always use two people to lift or use mechanical Lifting aid such as hydraulic lifting trolley.</p>
<p>Vehicle Support</p> 	<p>Always ensure vehicle is properly supported when working on it. Do not attempt to fit products whilst suspension work is being carried out. Do not work under a vehicle supported only by a jack.</p>

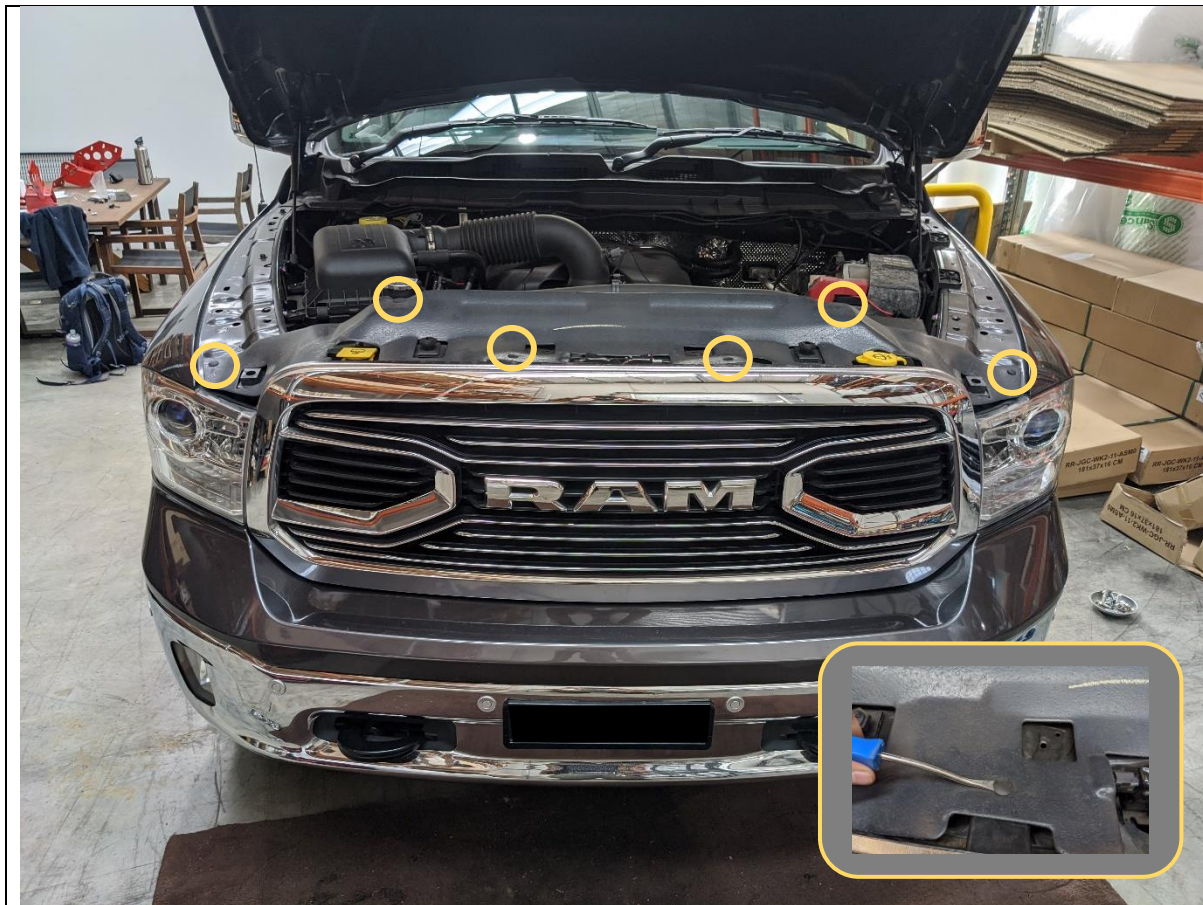

NOTE: The following steps show the removal of the split chrome type bumper as fitted to Laramie Models.

Procedure for removal of Full plastic bumper type as fitted to Express models, will be slightly different.

The fitment of the bullbar is the same for both models.

1. Open the Bonnet.
2. Remove the 6x Christmas tree clips securing the Radiator Shroud using a trim tool
3. Remove the Radiator shroud.

TOOLS REQUIRED

Trim Tool

FASTENERS

Retain Factory Clips.

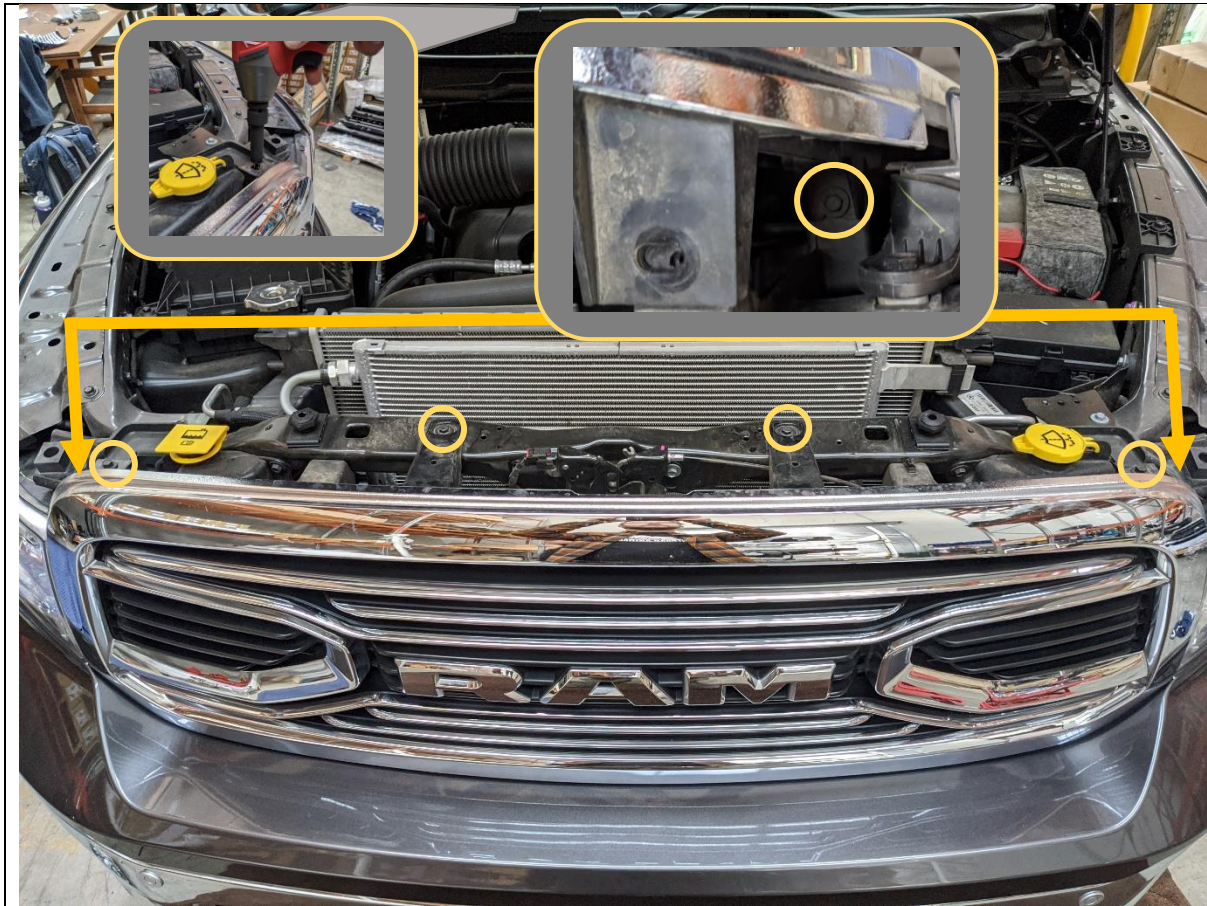

4. Remove the 4x 10mm head bolts securing the grille to the top crossmember.
5. Loosen, but don't remove the 2x recessed 8mm head bolts securing the side of the grille. An Extension bar will be required to access these bolts.

TOOLS REQUIRED

10mm Socket
8mm Socket
Extension bar

FASTENERS

Retain Factory

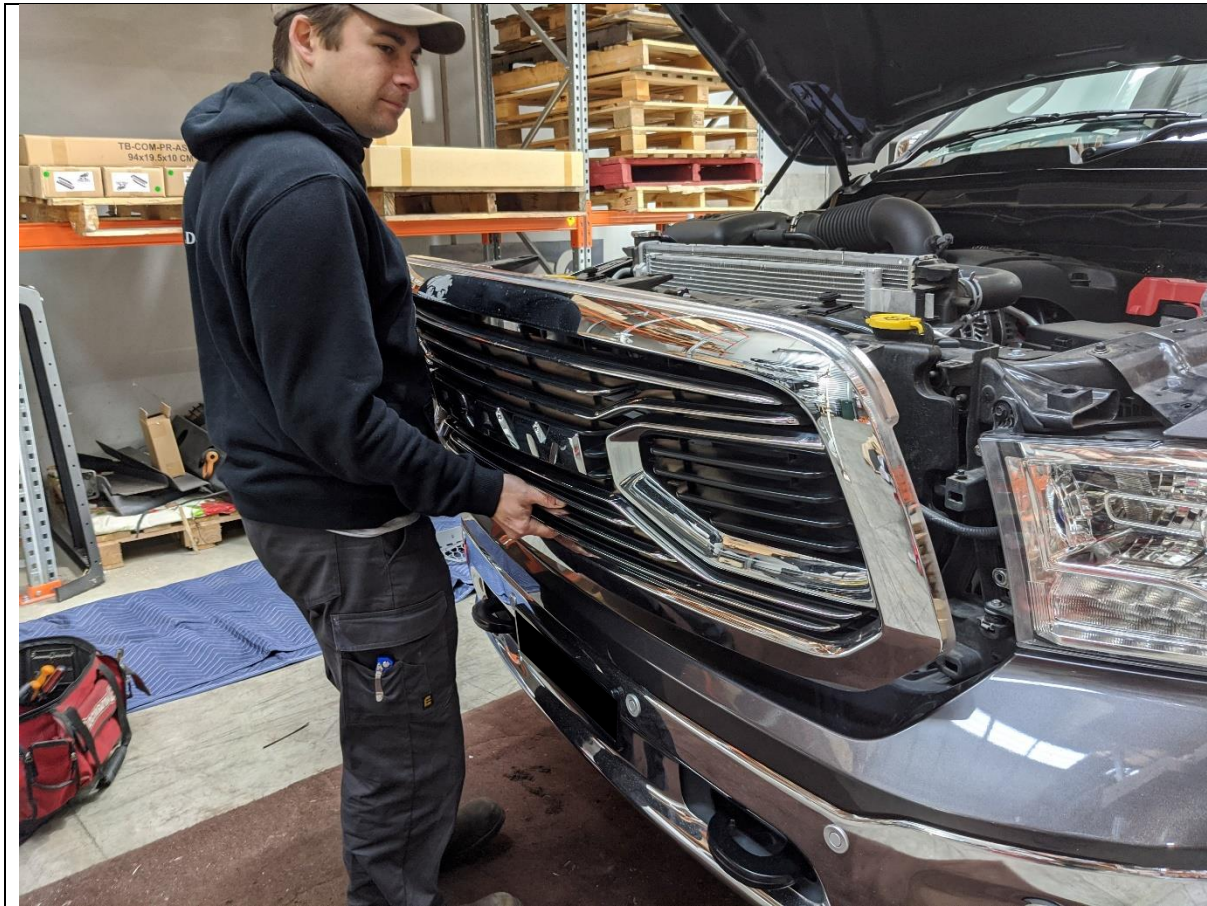

6. Remove the Grille, set aside on soft blanket to protect chrome finish.

TOOLS REQUIRED

FASTENERS

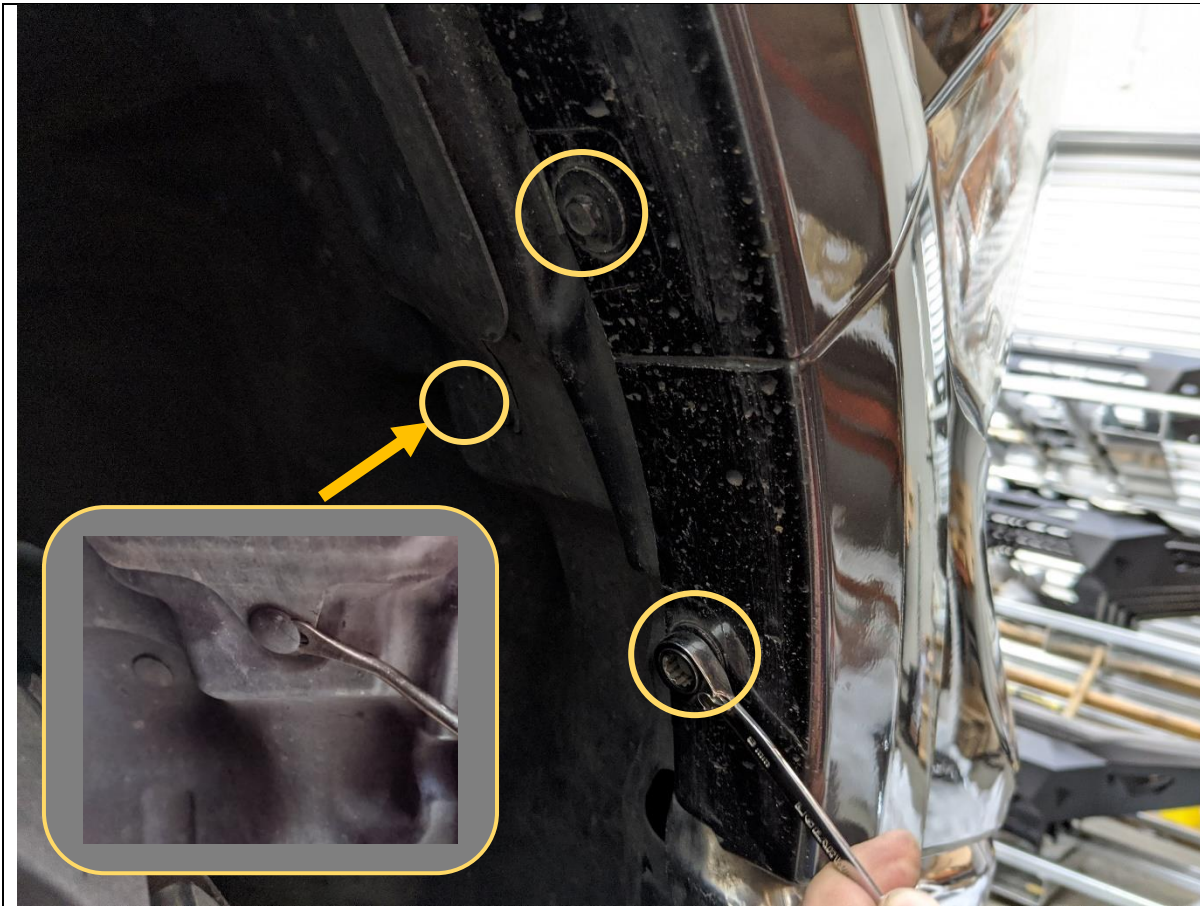

7. Remove 2x 8mm head screws in wheel arch securing wheel arch flare (Lamarie only) and inner guard liner.
8. Release the split clip that secures the headlight access hatch in the inner guard liner with trim tool.

TOOLS REQUIRED

8mm Spanner
Trim Tool

FASTENERS

Factory Split Clip
Factory 8mm Head coarse thread screw.

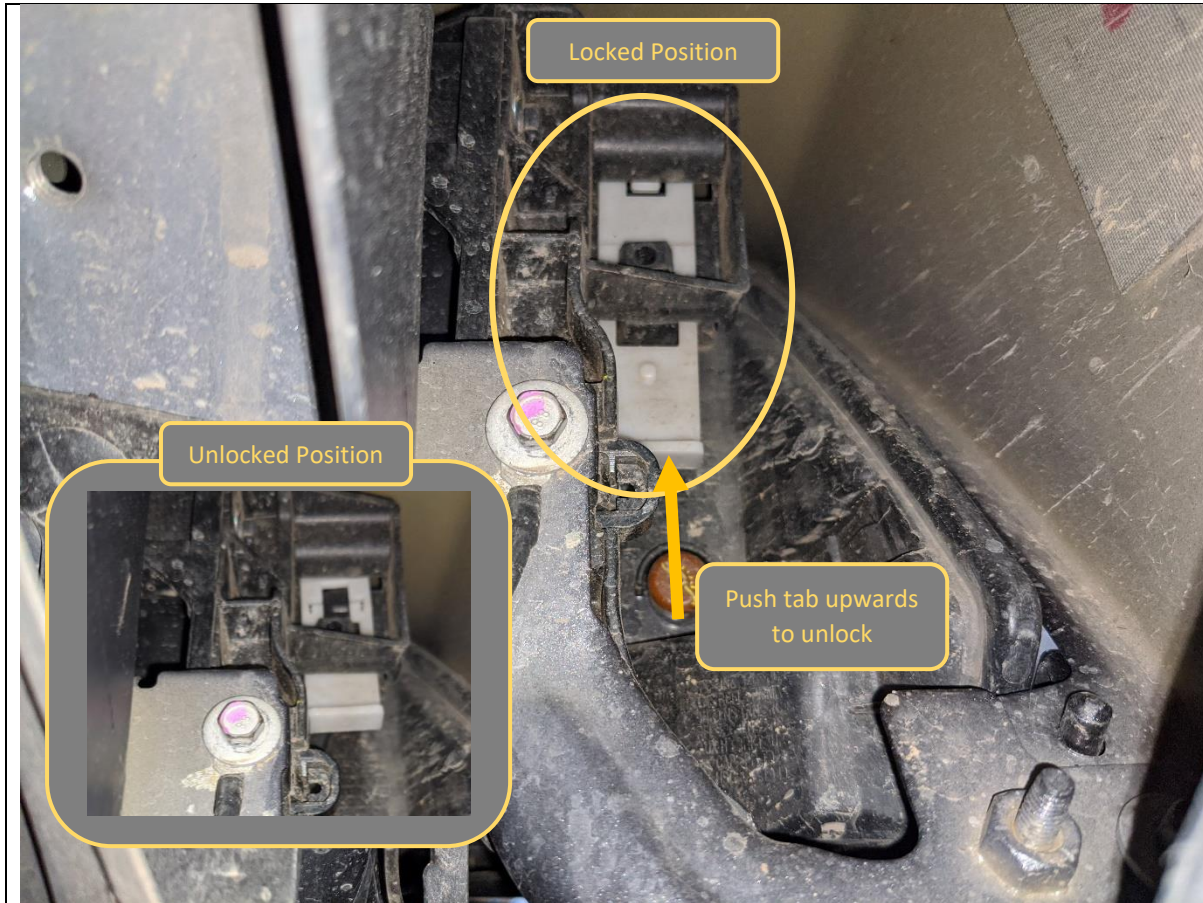

9. Reaching through the access hatch in the inner wheel arch liner, push up on the headlight securing tab to unlock the rear headlight mounting.
10. Complete steps 7-9 for other side of vehicle.

TOOLS REQUIRED

FASTENERS

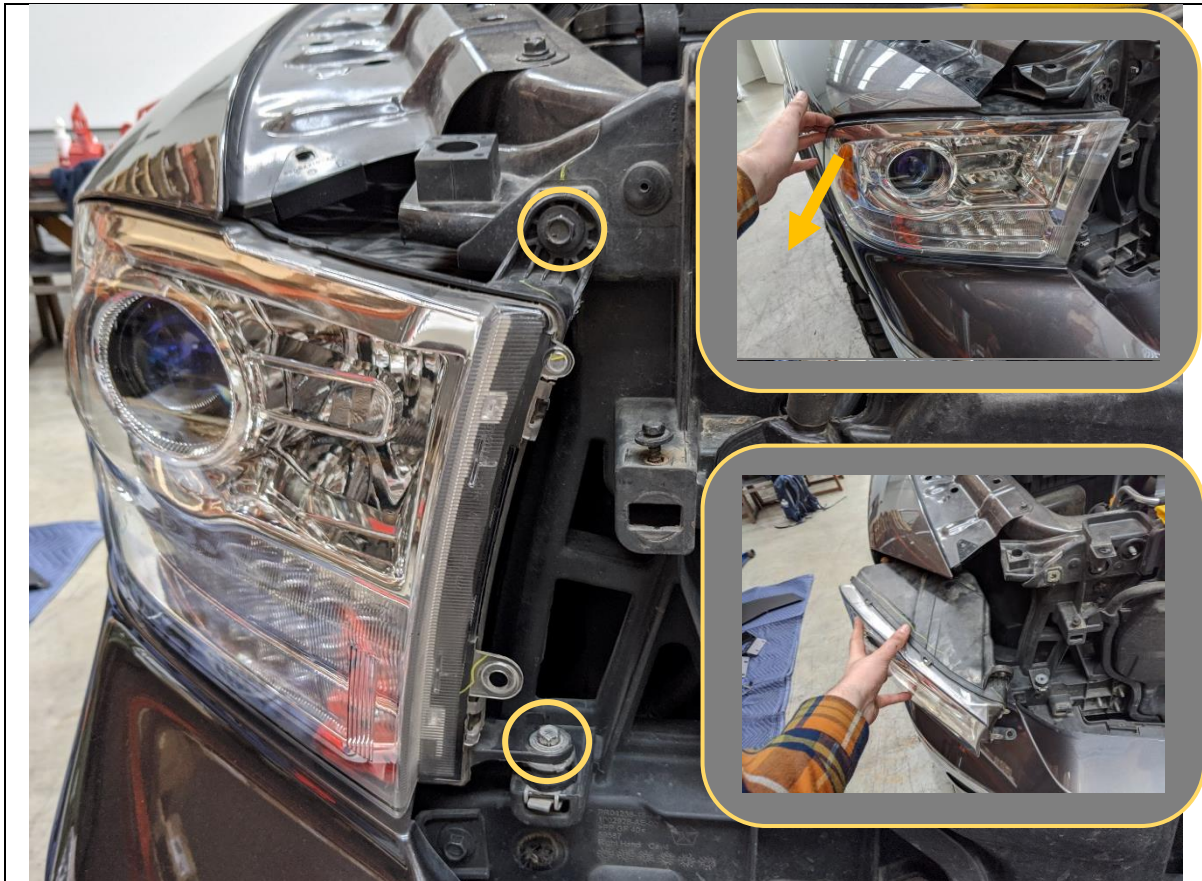

11. Remove the 2x 10MM head bolts securing the headlight to the vehicle.
12. With care, remove the headlight from the vehicle. Unplug harness and set aside in safe location. Also unplug small two pin parker plug.
13. Repeat for other side of vehicle.

TOOLS REQUIRED

10MM Socket
Extension Bar or
10mm Spanner

FASTENERS

Factory 10mm head bolts, retain for
reinstallation



14. With access through the headlight opening, remove the 10mm head bolt securing the upper bumper trim.

15. Complete for both sides of vehicle.

TOOLS REQUIRED
10mm socket (1/4" Recommended)
or
10mm Ratchet Spanner

FASTENERS

Discard



16. Using a Utility knife carefully cut the double-sided adhesive tape securing the wheel arch flare back to the bumper to guard joint in the body.

TOOLS REQUIRED

Utility Knife

FASTENERS

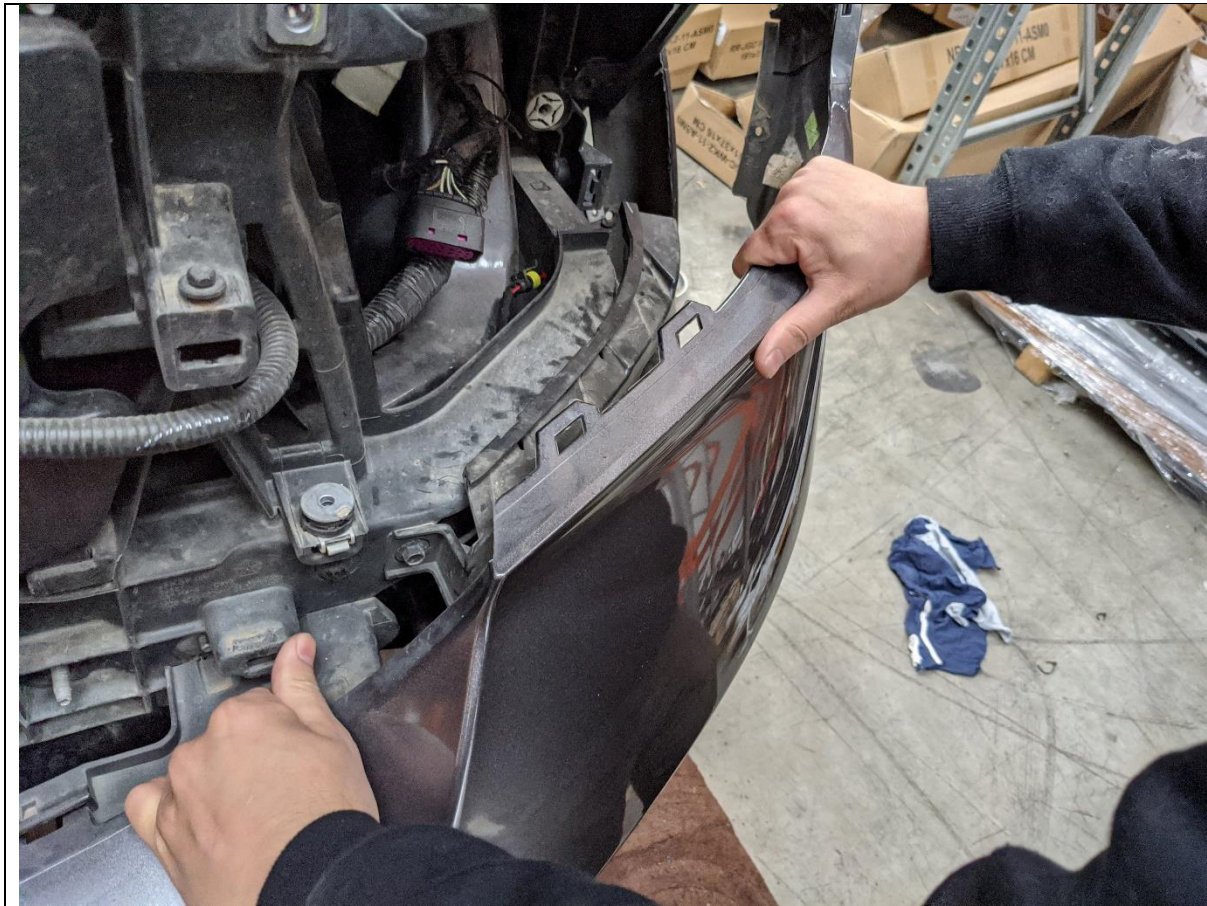

- 17. Remove the upper plastic bumper from the bumper supports.
- 18. Begin at the bumper to guard joint on both sides and work toward the middle, using a firm forward pull to release the clips.

TOOLS REQUIRED

FASTENERS



19. Once all clips are released remove the upper bumper from the vehicle.

TOOLS REQUIRED

FASTENERS



20. Remove the outer plastic bumper supports by removing the 3x 10mm head screws securing it to the crossmember.

An Extension bar will be required to reach the recessed holes.

Complete for both sides of vehicle

TOOLS REQUIRED

10mm Socket
Extension Bar

FASTENERS

Discard

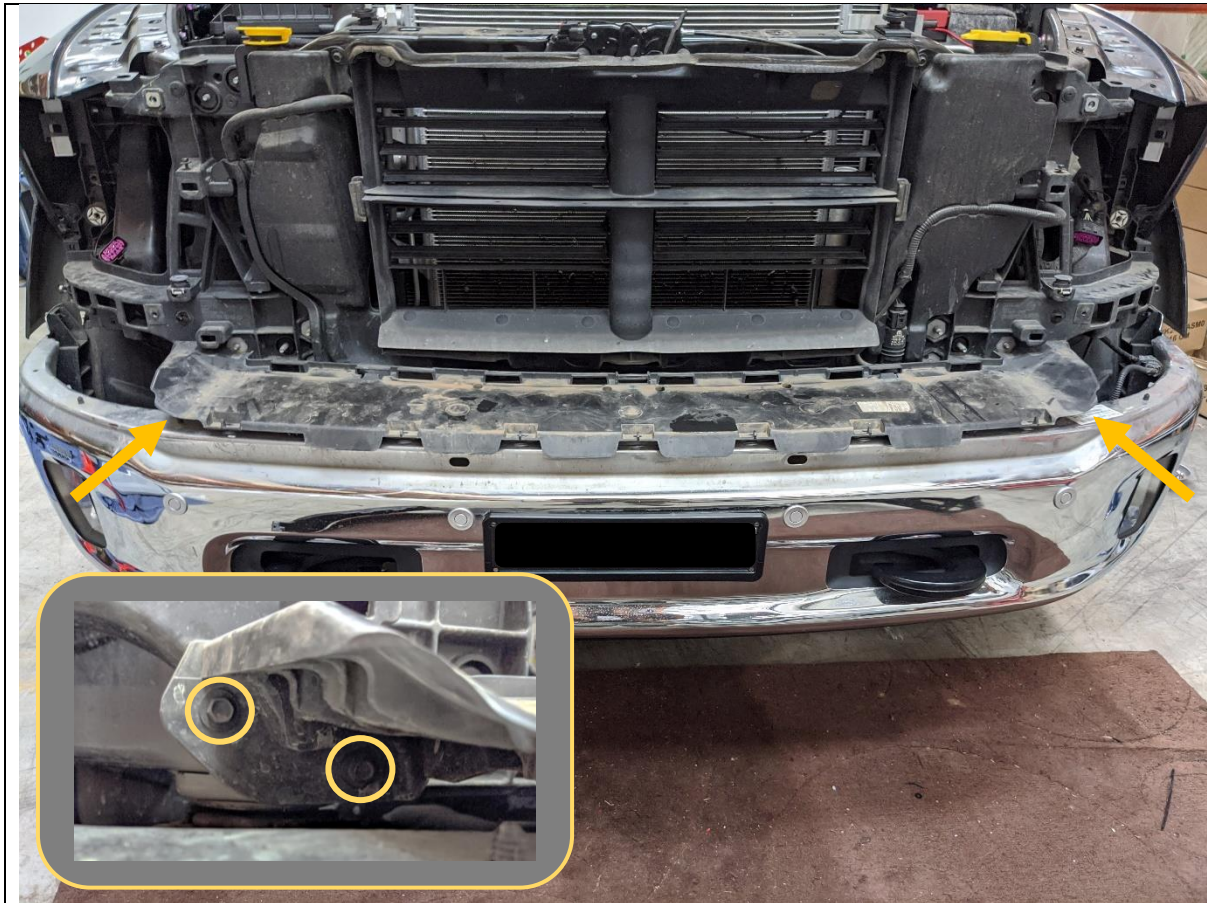

21. Remove the 4x 10mm head screws securing the center upper bumper support to the crossmember.
22. These fasteners are easiest to remove with an extension bar and socket.

TOOLS REQUIRED
10mm Socket
Extension bar

FASTENERS
4x 10mm Head factory screws.

Discard



23. From underneath the car, remove the 3x Xmas Tree clips that secure the air guide from the radiator shroud using a trim tool.

TOOLS REQUIRED

Trim Tool

FASTENERS



24. Remove the upper bumper support and air guide.

TOOLS REQUIRED

FASTENERS

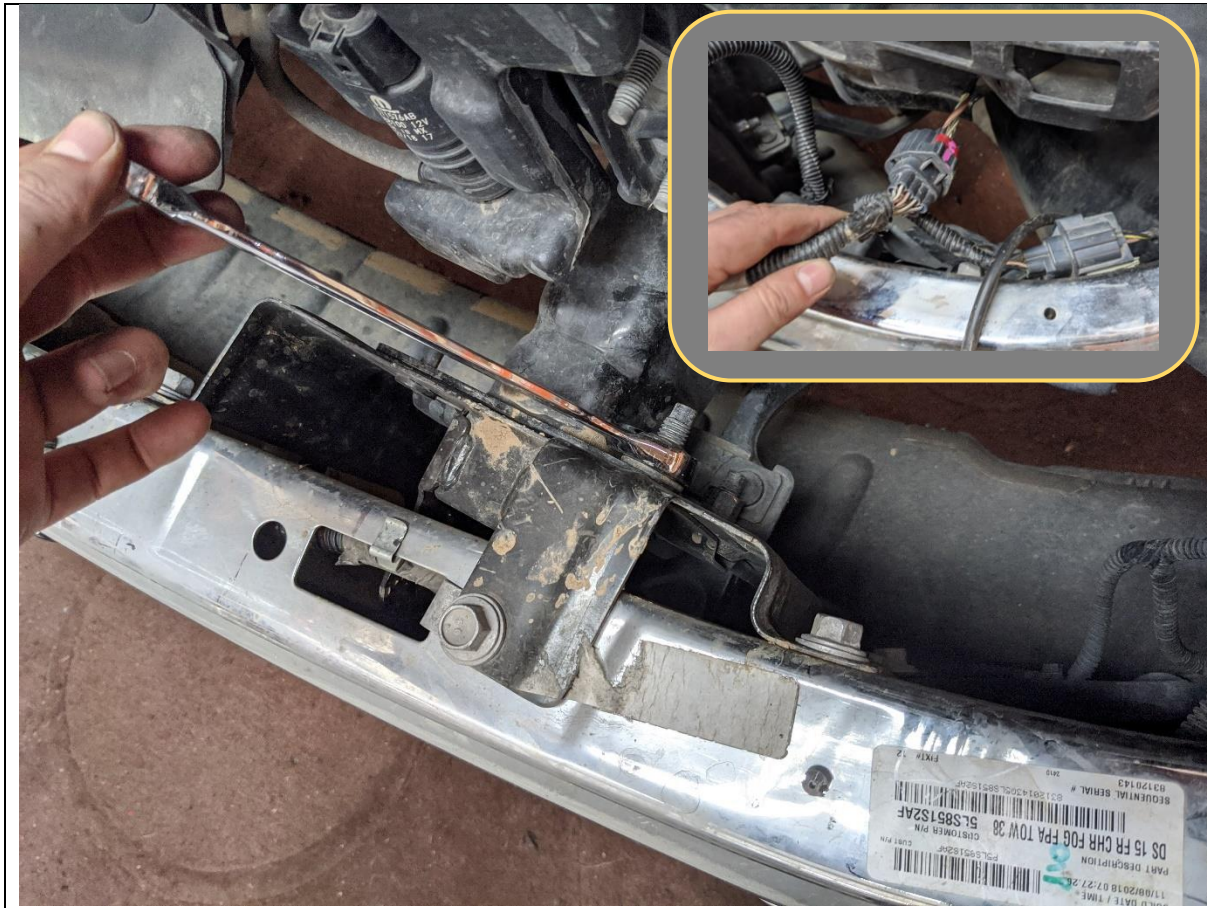

25. Disconnect the fog light and parking sensor looms, located underneath the LH headlight.
26. Pry harness plugs off the lower bumper using trim tool.
27. Remove the 6x 18mm head nuts securing the lower bumper to the chassis.

TOOLS REQUIRED

- Trim Tool
- 18mm Spanner

FASTENERS

- 6x 18mm Head Factory Nuts

Discard.



- 28. Remove front bumper by lifting forward off the car.
- 29. Set bumper aside and remove number plate.

TOOLS REQUIRED

FASTENERS



30. Remove the factory tow hooks, by removing the M12 Fine pitch bolt securing it to the chassis.

Once this bolt is removed, lift tow hook off locating pin on front face of chassis.

Complete for both sides of vehicle

TOOLS REQUIRED
18mm Socket

FASTENERS

M12 Fine pitch factory bolt – Retain for Reuse



<p>31. Fit the tow point to the chassis, with the M10x130 Bolt, Flat washers and M10 Nut through side, and M12 Fine pitch bolt – retained from tow points, on the underside.</p> <p>32. Note if fitting to express model use M12x40x1.5p Bolt supplied.</p> <p>33. Leave all bolts finger tight, complete for both sides of vehicle.</p>	<p>TOOLS REQUIRED</p>
	<p>FASTENERS</p> <p>M12 Factory fine pitch 1xM10x130 2xM10 Flat washer 1xM10 Nut Per side</p>

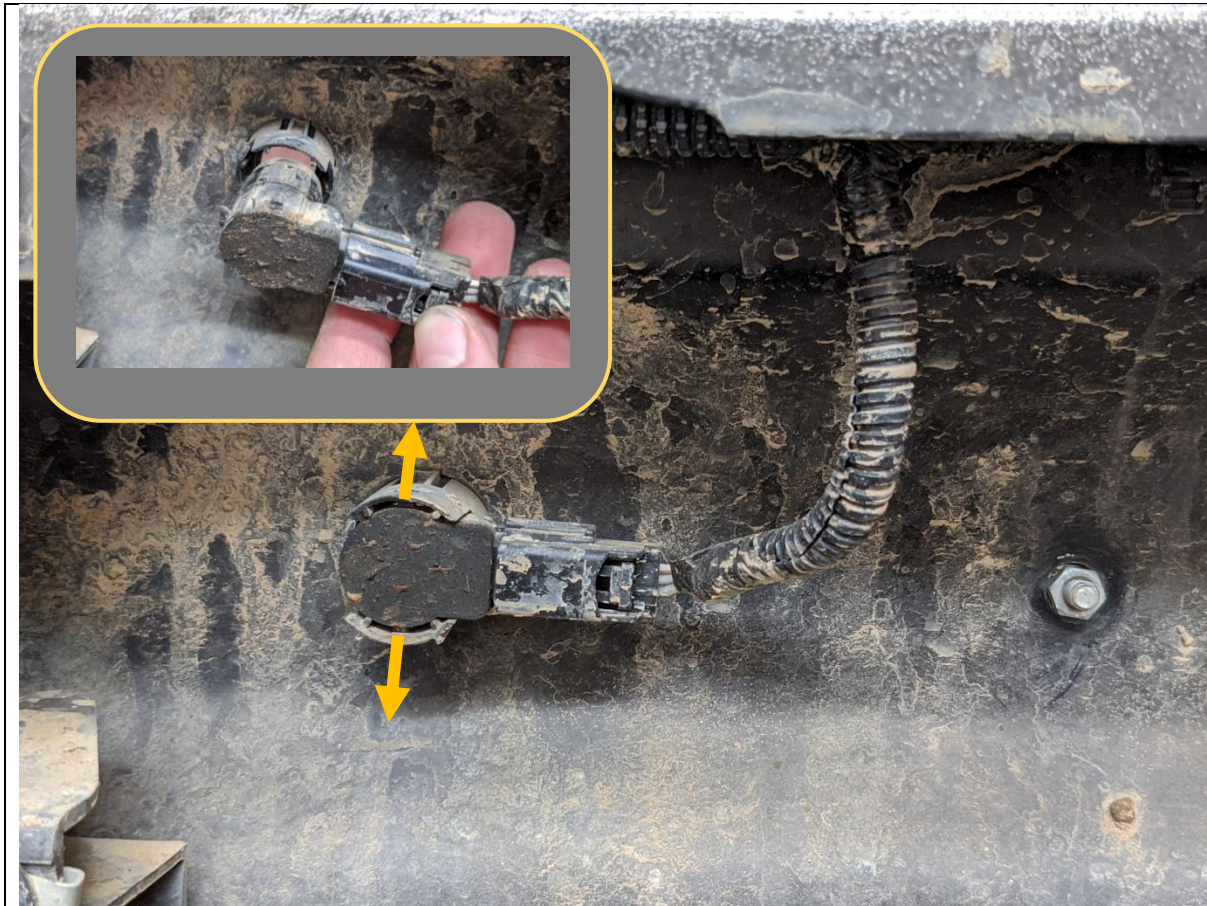

34. Remove parking sensors from housings. Gently pry apart housing, using a small flat screwdriver whilst pushing sensor through from the front side of the bar to release them.

TOOLS REQUIRED

FASTENERS



35. Remove sensor housings from front bumper. Squeeze on the 4x retaining tabs whilst pushing housing from back side of bar to release.

36. Remove from front side of bar. Note position sensor housings removed from to ensure correct location for refitting to Bullbar.

TOOLS REQUIRED

FASTENERS

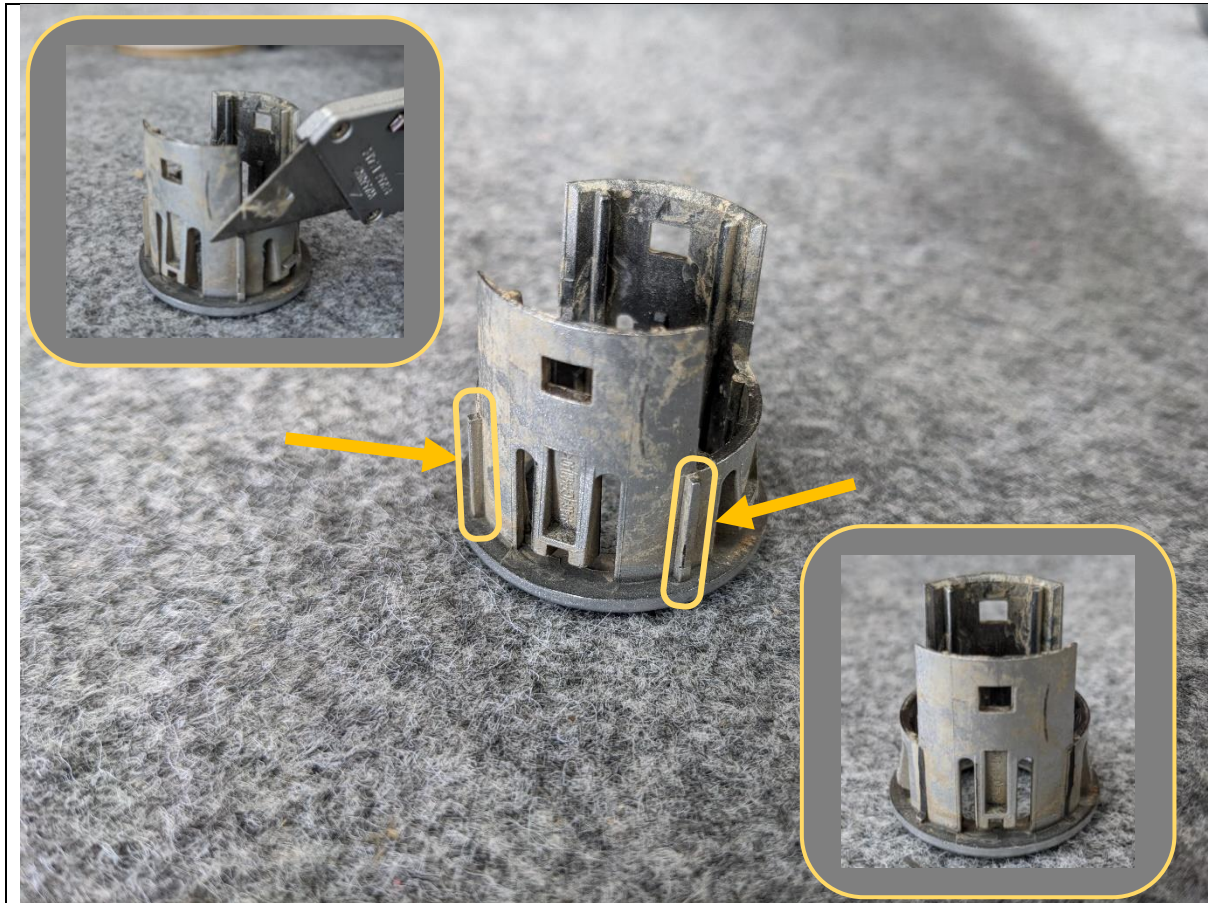

37. Sensor housings must be modified to fit in the Bullbar.

38. Locate the two ribs on the outside of the housings, these are located at different locations on different housings.

39. Using a utility knife cut the ribs off flush to the housing body

TOOLS REQUIRED

FASTENERS



- 40. Remove the sensor loom from the lower bumper, by prying off all clips securing the loom to the bumper with a trim tool.
- 41. Remove the Fog light loom from the lower bumper. First unplug the fog lights, then pry clips with trim tool.

TOOLS REQUIRED

Trim Tool

FASTENERS

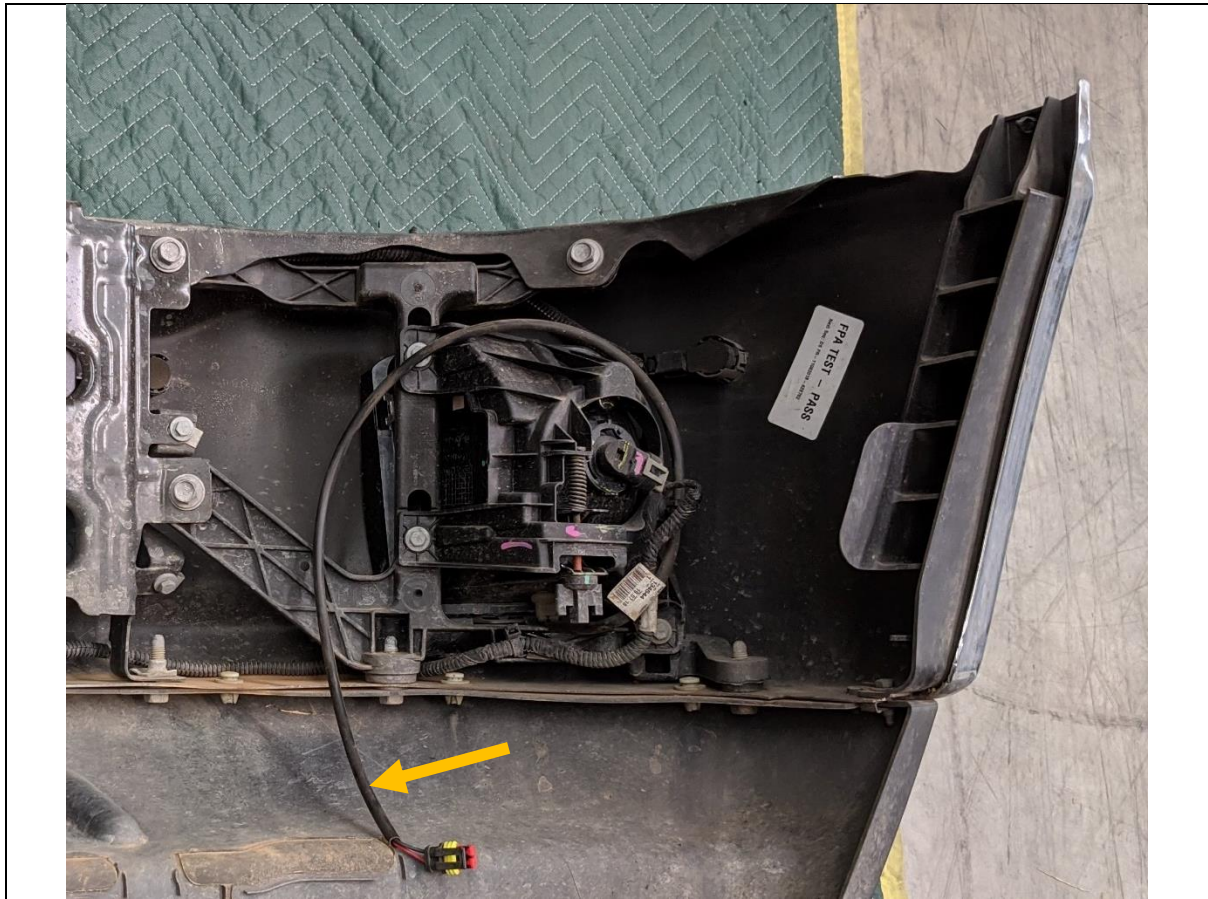

42. Remove the Parker light plug by cutting off close to factory parker location for re use on Offroad Animal Bar

TOOLS REQUIRED

Trim Tool

FASTENERS

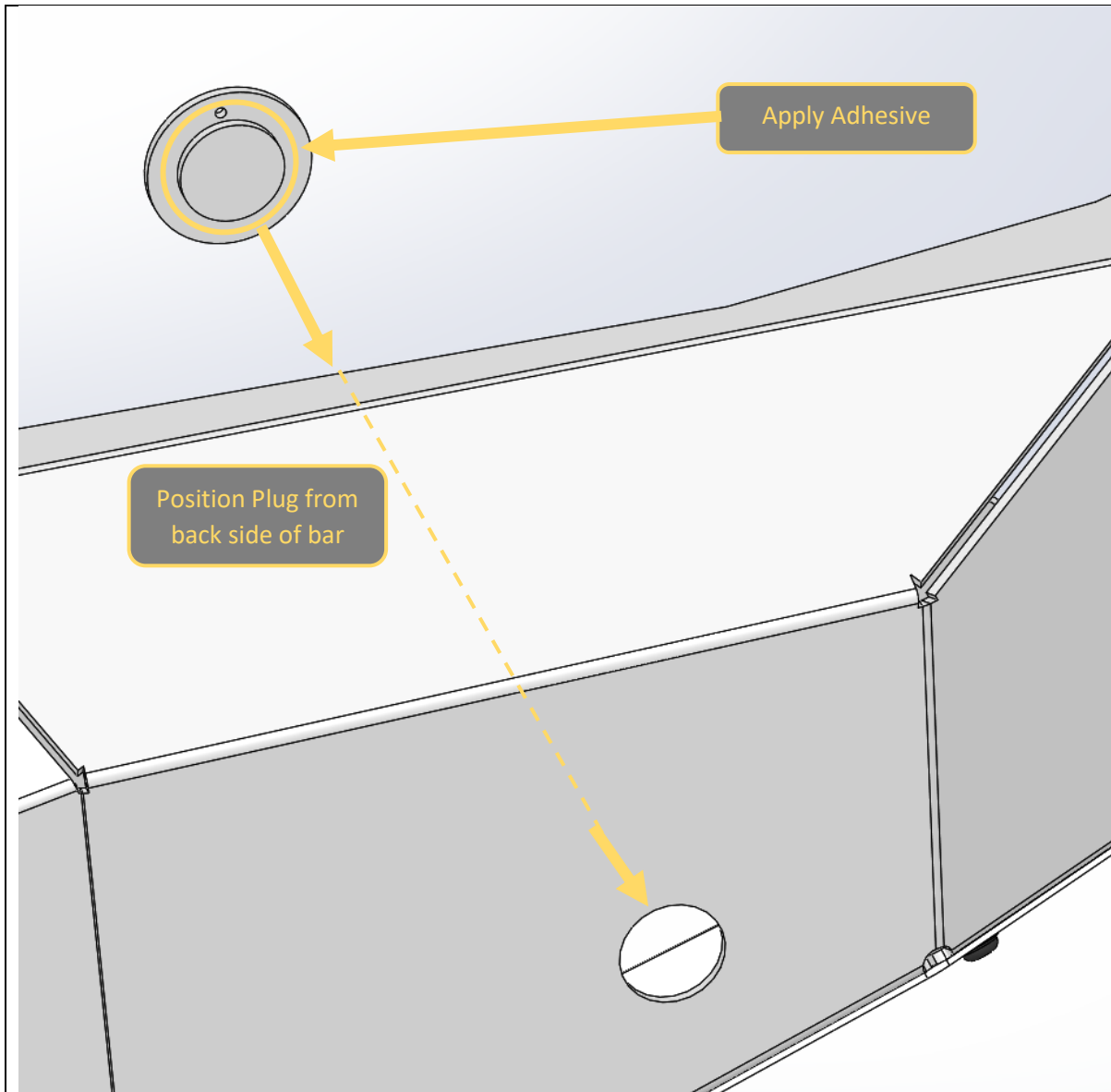

- 43. If fitting bar to Express model no parking sensors, fit the sensor plugs to the sensor holes in the bar.
- 44. Apply bead of automotive grade adhesive (such as Sikaflex 227) to the outside ring of the sensor plug.
- 45. Insert the sensor plug into the hole from behind. Ensure the plug sits flush with front of bar.
- 46. Wipe off all adhesive bleed through on front of bar with rag. Secure in place with tape until adhesive cures.
- 47. Skip all other steps related to parking sensor fitment

TOOLS REQUIRED
Automotive adhesive

FASTENERS

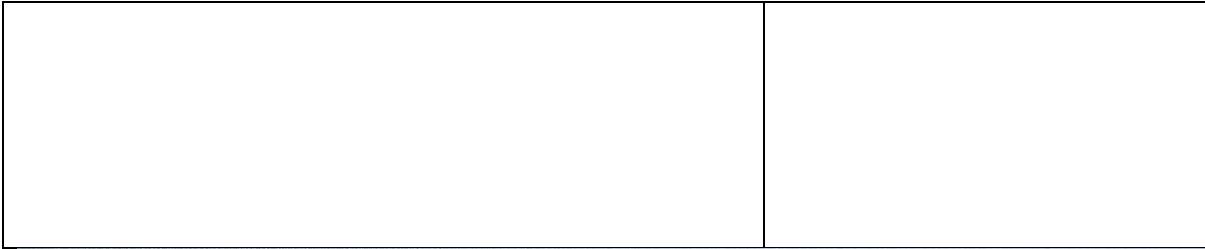

- 48. Fit sensor modified sensor housings into the bullbar, by pressing into holes in bar from the front side.
- 49. Take care to ensure that housings are inserted in original location.

TOOLS REQUIRED

FASTENERS



50. Pass wiring loom through bar uprights, starting from the left-hand side of the bar.

TOOLS REQUIRED

FASTENERS



<p>51. The wiring harness for the parking sensors needs to be extended.</p> <p>52. Loom extension of 600mm is required.</p> <p>53. It is recommended to extend the loom one wire at a time.</p>	<p>TOOLS REQUIRED</p> <p>Wire cutters Wire strippers Soldering Iron Tape Split Tubing</p>
<p>54. Cut each wire, and solder in 600mm extension. Ensure all connections are electrically sound and properly insulated. Heat shrink is recommended.</p> <p>55. Once all wires extended, wrap extension in electrical tape and protect with split tubing.</p> <p>56. Once loom extension is complete finish running sensor harness through the bar.</p>	<p>FASTENERS</p> <p>Solder</p>



- 57. Fit parking sensors into housings. Push sensors into housings until the retaining tabs hold each sensor in place.
- 58. Pressure may need to be applied to front side of housing whilst pushing in sensors to prevent it pushing through bar.
- 59. Plug in all sensors to sensor harness.

TOOLS REQUIRED

FASTENERS



- 60. Fit 5x cage nuts to rectangle slots on the bottom edge of wing. Repeat for both sides of vehicle.
- 61. Use small flat blade screwdriver to assist in setting cage nuts in position

TOOLS REQUIRED

Small Flat screwdriver

FASTENERS

10x M6 Cage Nuts

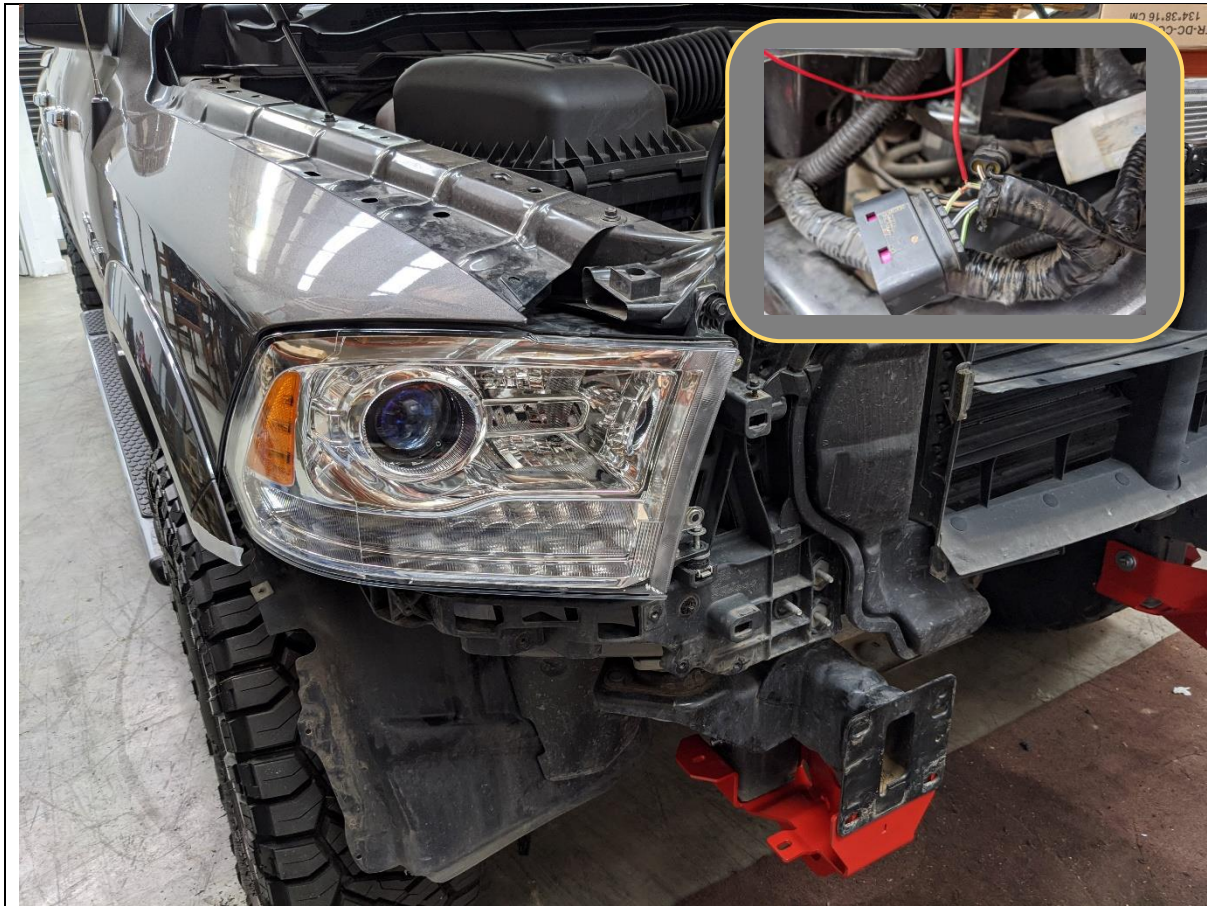

- 62. If fitting driving lights, complete wiring for high beam pickup now, as wiring will not be easily accessible once bar is installed.

- 63. Fit parker lamp leads removed from bumper to twin pin plugs near headlight harness connector. Leave ends of leads in accessible location.

- 64. Re fit headlights to vehicle. Process is reverse of removal, replace bolts and lock retainer clip accessed through hatch in wheel arch.

TOOLS REQUIRED
10mm Socket

FASTENERS
Re use factory



<p>65. For Warlock models Grille needs to be trimmed to allow fitment of bar.</p> <p>66. Cover trim area on bottom corners of grille in masking tape</p> <p>67. Mark position 85mm from corner in vertical directions. Mark position in line with crease in grille in horizontal direction.</p>	<p>TOOLS REQUIRED Masking Tape Air Hacksaw</p>
<p>68. Mark cut line vertically from inside point, up until the step in the grille height, then diagonally across to vertical position marked.</p> <p>69. Trim along line marked with air hacksaw.</p> <p>70. Once bar is fitted assess gaps and adjust with extra trim as required to achieve uniform gap side to side.</p>	<p>FASTENERS</p>

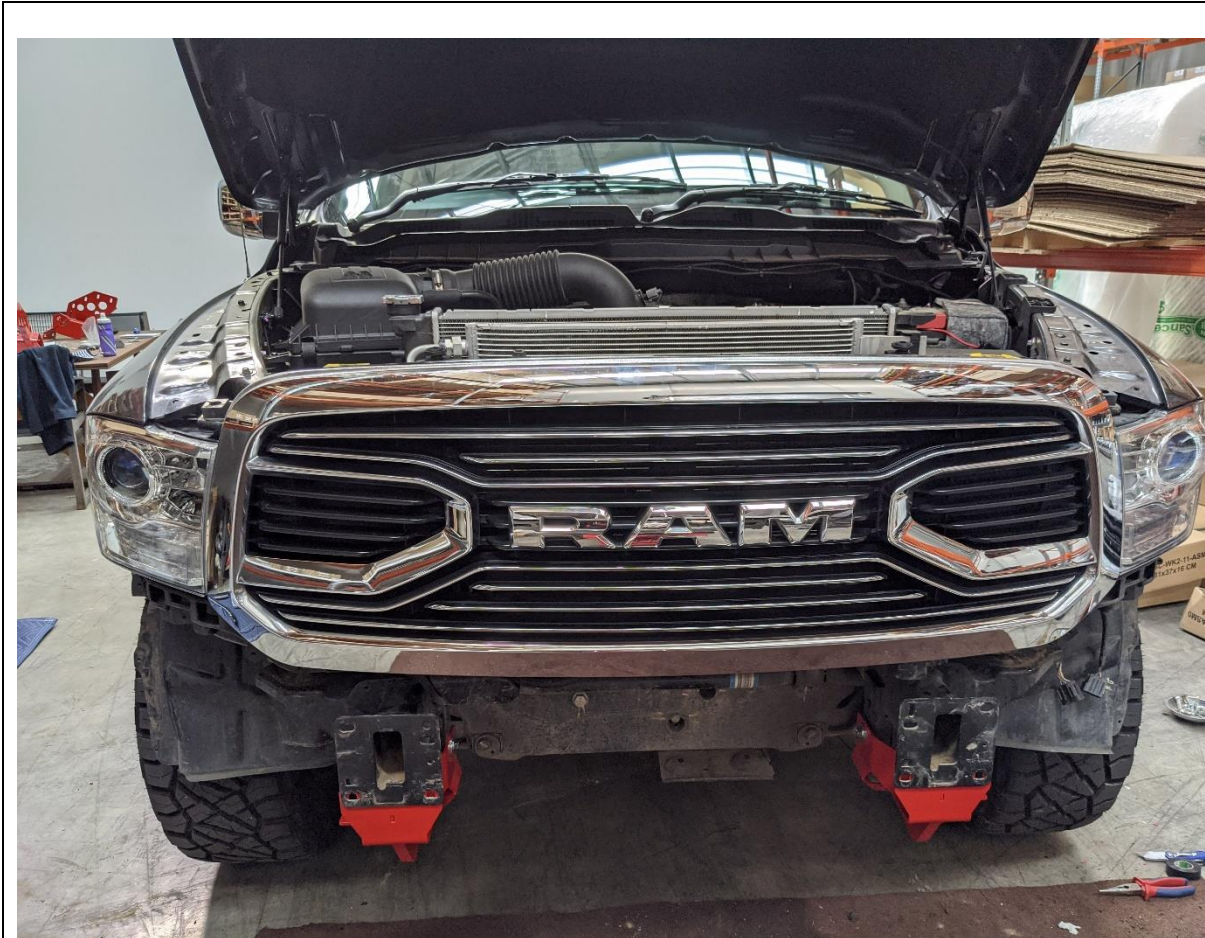

71. Re Fit Grille to vehicle, replacing the 4x 10mm factory bolts.

TOOLS REQUIRED

- 10mm Socket
- 8mm Socket
- Extension Bar

FASTENERS

4x Factory Bolts re used



- 72. For Laramie models the wheel arch flare needs to be trimmed.
- 73. Place masking tape on flare in location shown.
- 74. Mark cut position inline with bottom of headlight, to the intersection of the molded bumper line then down as shown in image above.
- 75. Carefully cut the line as marked with an angle grinder or air hacksaw.

TOOLS REQUIRED
Angle Grinder
Or
Air Hacksaw

FASTENERS

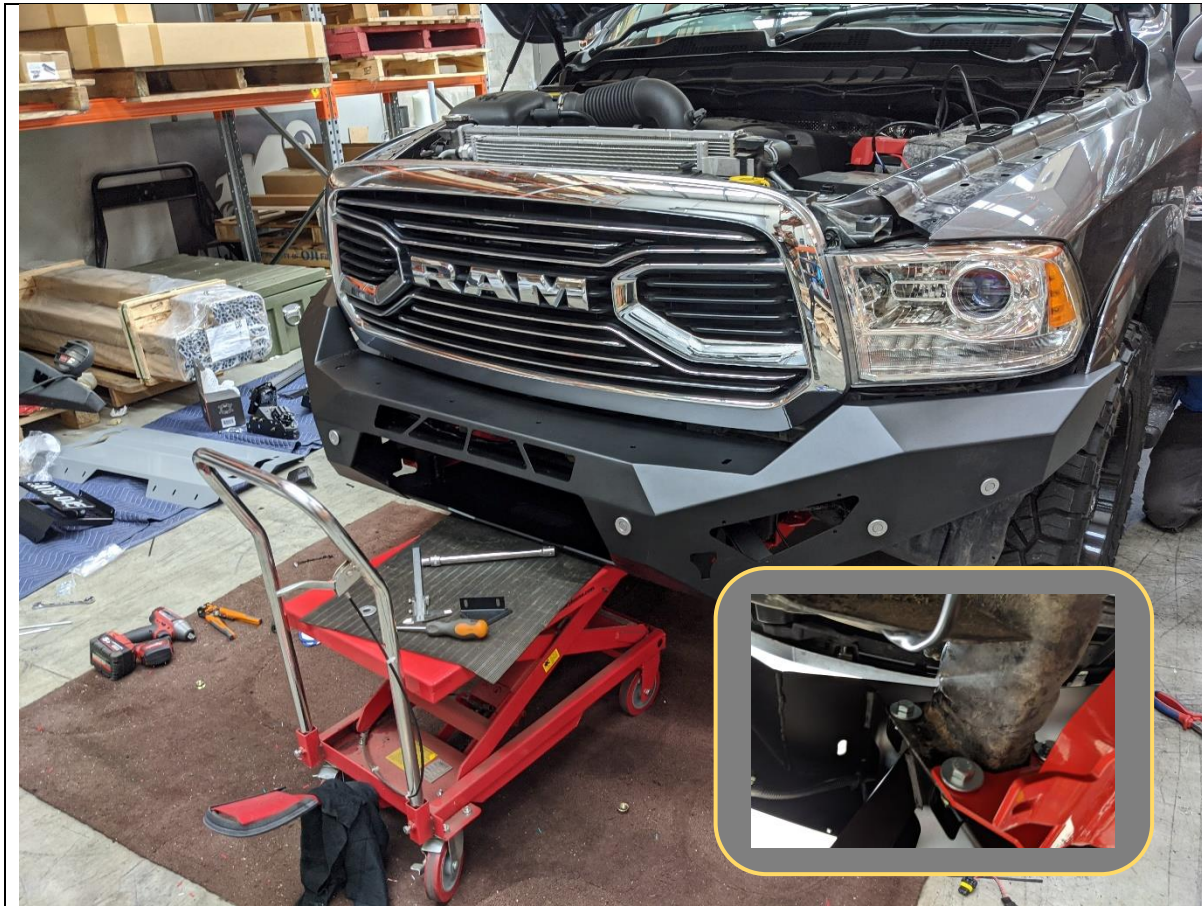

- 76. Using a lift trolley fit the bar to the vehicle.
- 77. Once in position fit secure with the main mounting bolts. Bottom bolts are M12x40 with 2x Large Flat washers and M12 Nyloc Nut.

Top Outside bolt is M12x30 with 2x Large Flat washers and M12 Nyloc Nut

Top Inside bolt is M10x30 with 2x M10 washers and M10 Nyloc Nut
- 78. Ensure bar is centered and has even gap of approx. 10-15mm on both sides near headlight. Tighten all bolts to lock in place.

TOOLS REQUIRED
18 & 19mm Socket /
Spanner
16 & 17mm Socket
and Spanner
Lift Trolley

FASTENERS
4x M12x40 Hex Bolt
2x M12x30 Hex Bolt
2x M10x30 Hex Bolt
12x M12 Large
Washer
4x M10 Flat Washer
6x M12 Nyloc Nut
2x M10 Nyloc Nut



- 79. Fit the winch brace bracket.
- 80. First fit to winch cradle with M10x30 bolt, Flat washer and Flange Nut.
- 81. Next remove the M10x130 bolt through tow point and re-fit with brace in position.
- 82. Repeat for both sides of vehicle.
- 83. Tighten all bolts

TOOLS REQUIRED
16mm Spanner

FASTENERS
2xM10x30
2xM10 Flat washer
2xM10 Flange Nut



<p>84. If Fitting an integrated light bar, do so now. Leave bolts loose at this stage to allow fitment of mesh panels.</p> <p>85. The bar is designed to fit a STEDI ST3K 21.5 inch light bar. If fitting this light bar, assemble bar with legs Outward, and it will line up with the slots in the center gusset.</p> <p>86. The bar can accommodate most other “20 inch” size light (20-22 inch long) bars.</p>	<p>TOOLS REQUIRED</p>
<p>87. If Fitting a winch, do so now.</p> <p>88. The bar is designed to fit most low mount winches, in foot down configuration. WARN 16.5ti is largest winch confirmed to fit.</p> <p>89. The control box can be mounted on top of the winch. Winches usually come with a bracket to allow this. Refer to winch manufacturer.</p>	<p>FASTENERS</p>



<p>90. Prepare the Center mesh panel for fitment.</p> <p>91. If Required, Fit winch fairlead to Mesh Fairlead Mount. Use M10 or 3/8" Fasteners supplied with winch. The bar is only compatible with Hawse type fairleads.</p> <p>92. Fit Number plate flip kit to fairlead mount, using fasteners supplied in kit.</p>	<p>TOOLS REQUIRED</p>
	<p>FASTENERS</p>



93. Fit the Mesh Fairlead Mount to the center of the bar, using M8x16 Button head (Top), M8x20 Button Head (Bottom) M8 Flat washers and M8 Flange Nuts.

94. Tighten fasteners using 13mm socket / spanner and 5mm Allen Wrench.

TOOLS REQUIRED
13mm Spanner
5mm Allen Wrench

FASTENERS

2x M8x16 Button Head
2x M8x20 Button Head
4x M8 Flange Nut
4xM8 Flat Washer



- 95. Fit Mesh Infill Panels. Use 2x M8x16 Button head bolt, M8 flat washer and M8 flange nut for top mount
- 96. Don't fit any bolts to bottom holes at this stage.
- 97. Tighten top fasteners using 13mm socket / spanner and 5mm Allen Wrench.
- 98. Once the top bolts are tightened, Use supplied M8x20 Button head bolt, Flat washer and Flange Nut to secure the integrated light bar.

TOOLS REQUIRED
13mm Spanner
5mm Allen Wrench

FASTENERS
4x M8x16 Button Head
2x M8x20 Button Head
6x M8 Flat Washer
6x M8 Flange Nut



<p>99. Remove the M12 fine pitch bolts on the bottom face of the tow point.</p> <p>100. Fit Center Bash Plate using, M8x20 button heads, flat washers and flange nuts to front face. Ensure these fasteners pass through the side mesh panels also.</p> <p>101. Secure back of Center Bash Plate using the M12 Fine pitch bolts removed earlier</p>	<p>TOOLS REQUIRED</p> <p>18mm Spanner 18mm Socket 5mm Allen Key 13mm spanner</p>
<p>102. Tighten Bottom fasteners using 18mm spanner or Socket</p> <p>103. Tighten front fasteners using 13mm socket / spanner and 5mm Allen Wrench. Reach through access hole in mesh panel to reach nut.</p>	<p>FASTENERS</p> <p>6x M8x20 Button Head 6x M8 Flange Nut 6xM8 Flat Washer</p>

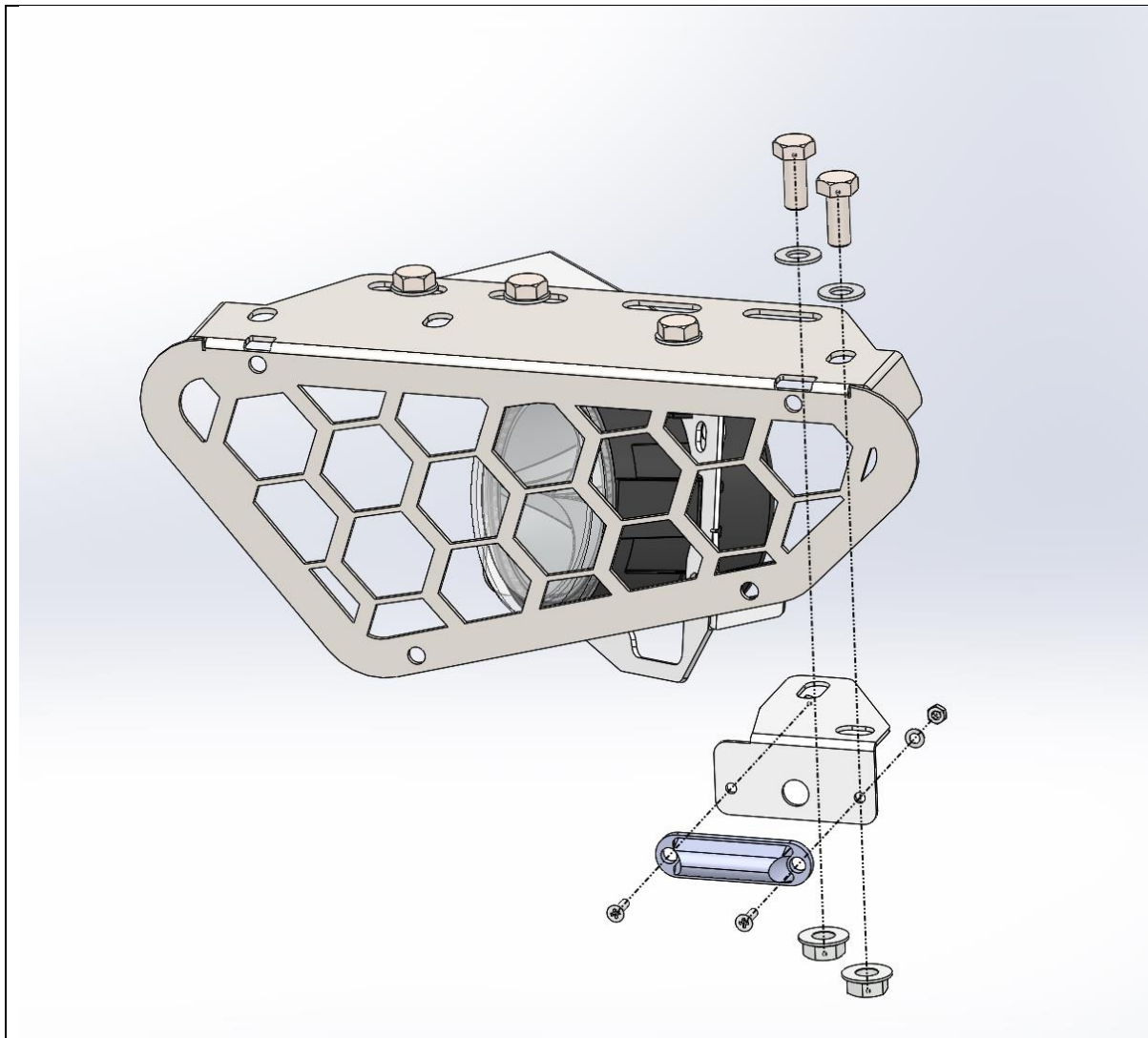

- 104. If fitting Stedi fog lights, fit them to the fog light brackets supplied. Note that the fog light brackets are handed. Use the screw supplied in the STEDI Kit and 4x M6 Flange Nuts
- 105. Fit the fog light brackets to the light mesh panels using 3x M8x20 bolts, flange nuts and flat washers per side.
- 106. Fit the parker lamps to the brackets, using supplied M3 Fasteners, then fit the parker lamp bracket to the Light mesh using 2x M8x20 bolts, flange nuts and flat washers per side.

TOOLS REQUIRED
Phillips Head
Screwdriver
13mm Spanner / Socket

FASTENERS



<p>107. Fit the light mesh to bar, position from underneath and securing with 4x M6x16 Button head bolts, Flat washers and M6 Flange Nuts.</p> <p>108. Secure and tighten using 4mm Allen Key and 10mm Spanner</p>	<p>TOOLS REQUIRED 4mm Allen Key 10mm Spanner / Socket</p>
<p>109. Run fog light harness removed from bumper through bar and Re Connect fog light wiring connectors.</p> <p>110. Wire parkers to leads positioned in step 63.</p>	<p>FASTENERS 4x M6x16 BHCS – Black 4x M6 Flat Washer 4x M6 Flange Nut Per side</p>



<p>111. If fitting stealth hoop do so at this stage, using fasteners supplied with stealth hoop kit</p> <p>112. Bolt locations can be reached from underneath the wing.</p>	<p>TOOLS REQUIRED 4mm Allen Key 10mm Spanner / Socket</p>
	<p>FASTENERS</p> <p>4x M6x16 BHCS – Black 4x M6 Flat Washer 4x M6 Flange Nut Per side</p>

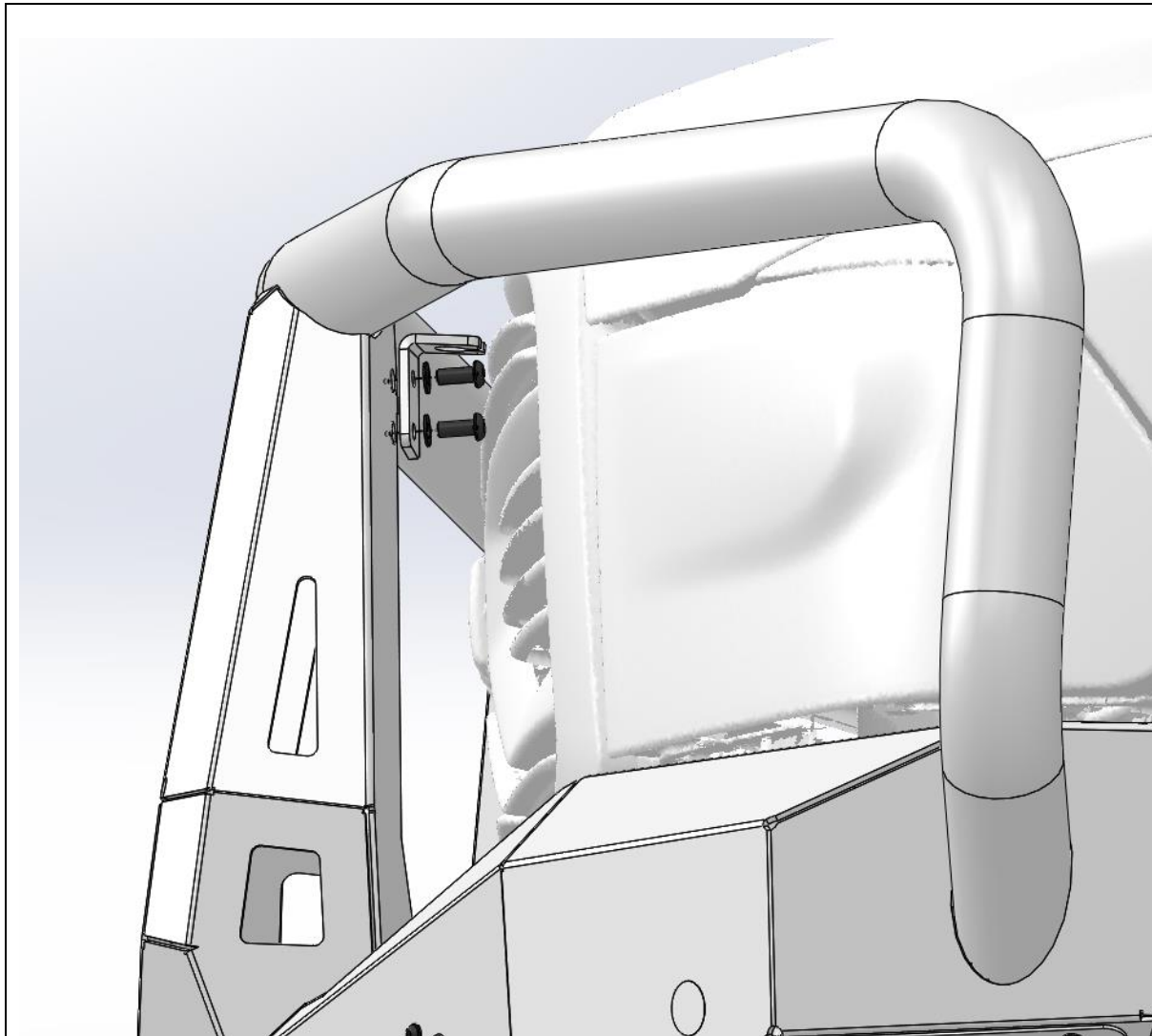

113. For Toro Bar, if fitting antenna brackets do so now.

114. Fit antenna bracket to weld nuts in back side of uprights using M8x20 BHCS and M8 Flat Washers

TOOLS REQUIRED

5mm Allen Key

FASTENERS

2x M6x20 BHCS – Black
2x M8 Flat Washer
Per side

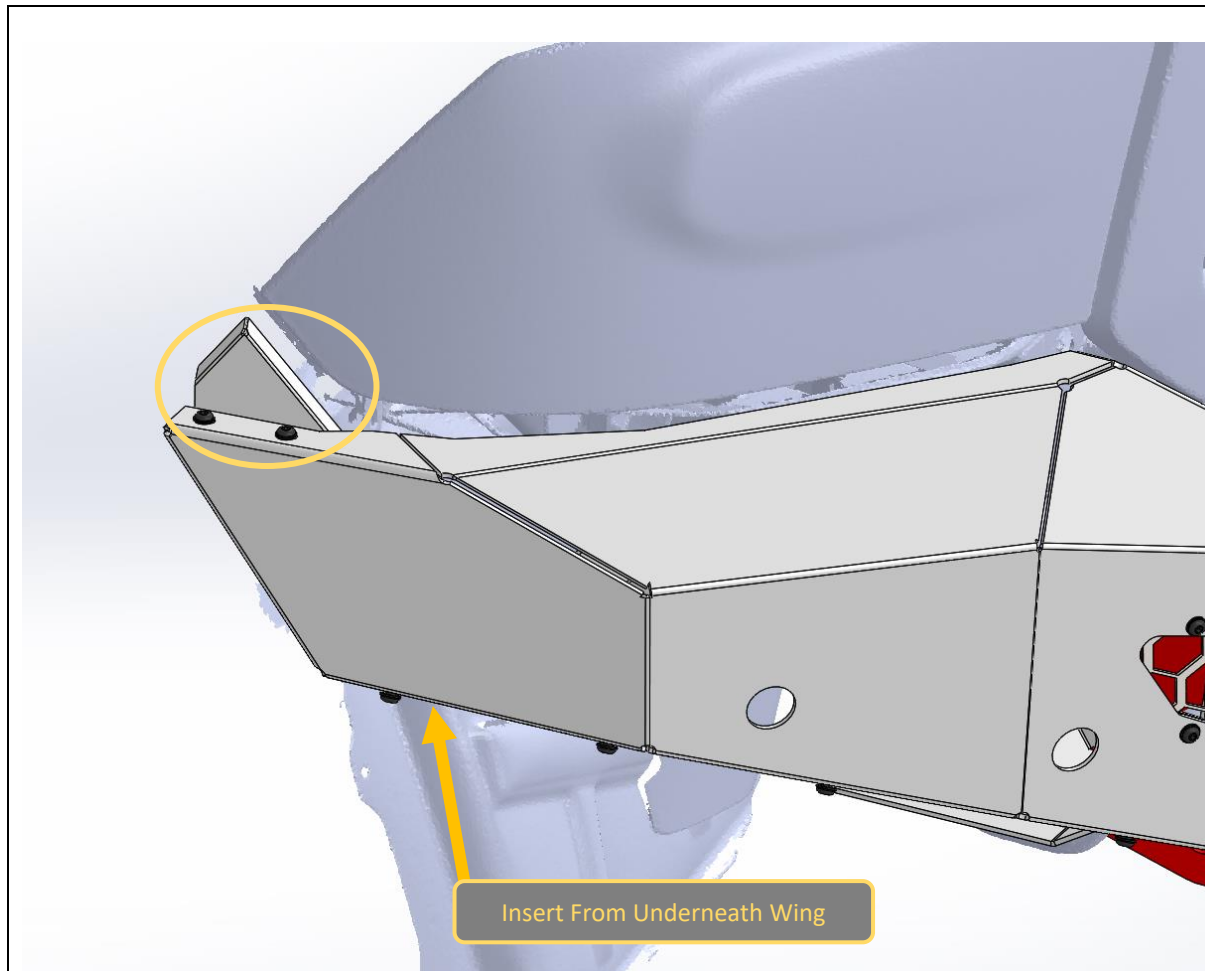

<p>115. For Express Models, fit the headlight infill panels to the gap between the wing and headlight using M6x16 Button Head Bolts, Flat washers and Flange Nuts.</p> <p>116. Infills fit from underneath wing and sit under the top face of the wing.</p> <p>117. This step is not required for Laramie models as area is covered by wheel arch flare</p>	<p>TOOLS REQUIRED 4mm Allen Key 10mm Spanner / Socket</p>
	<p>FASTENERS 4x M6x16 BHCS – Black 4x M6 Flat Washer 4x M6 Flange Nut Per side</p>



- 118. Loosely Fit side under panels using M6x16mm Socket head screws into the cage nuts in the wing, fitted earlier.
- 119. Complete for both sides of vehicle

TOOLS REQUIRED

FASTENERS

- 10x M6x16 Button Head Screws
- 10x M6 Flat Washer

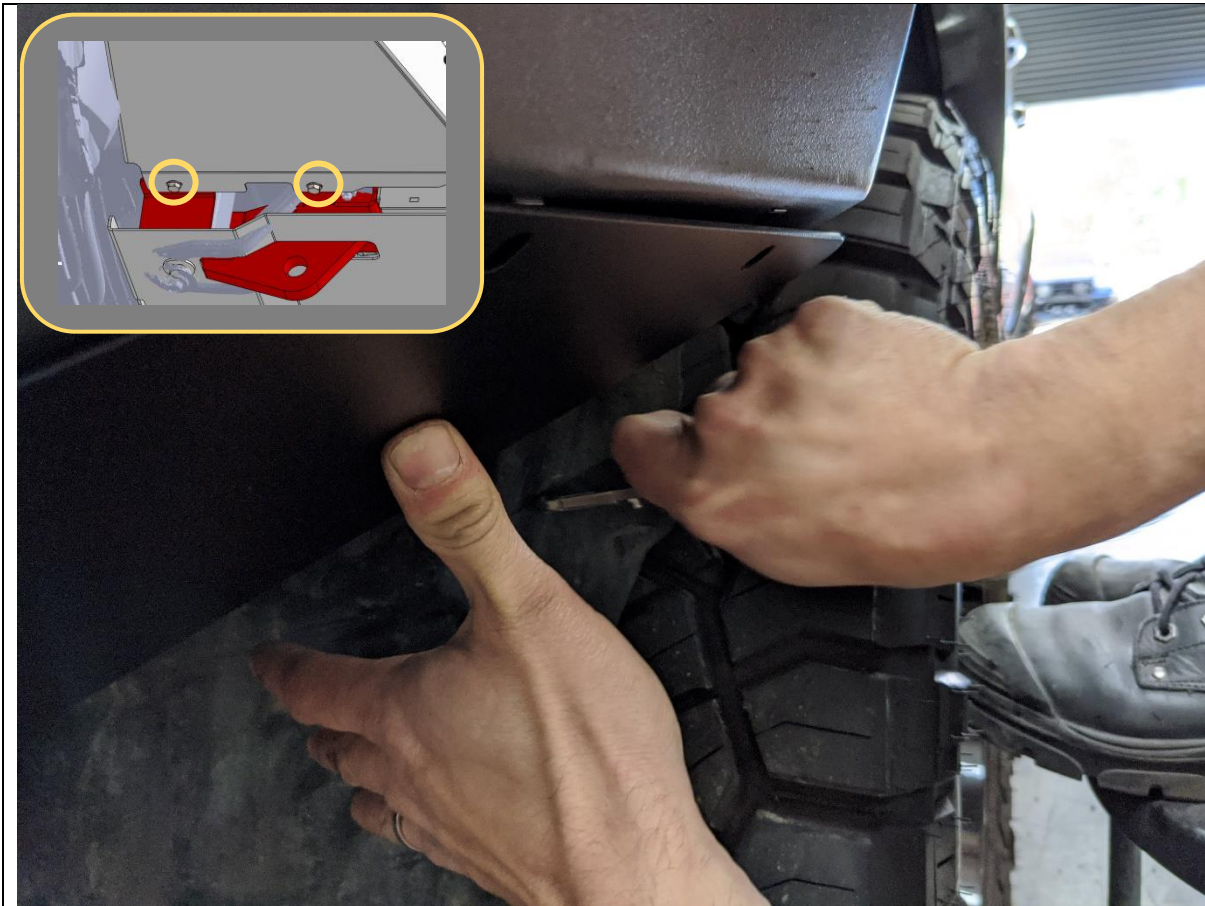

120. Using the edge of the under panel as a guide, trim the wheel arch liner to the profile of the under panel, with an approximate 20mm overhang.

121. Use a sharp utility knife to cut the wheel arch liner.

122. Tuck the wheel arch liner behind the flanges on the under panel.

123. Fit the bottom support M8x20 bolts to secure the under panel to the tow points

124. Tighten all bolts securing under panel.

TOOLS REQUIRED
4mm Hex Key
13mm Socket / Spanner

FASTENERS
4x M8x20 Bolt,
4x M8 Flange Nut
4x M8 Flat Washer



<p>125. Re Check all Fasteners are tight.</p> <p>126. Re-Fit Number Plate to number plate flip.</p> <p>127. Your done. Hit the tracks and enjoy your newly protected RAM!</p>	<p>TOOLS REQUIRED</p>
	<p>FASTENERS</p>